

MÉMOIRES DE LA S. M. F.

ENRIQUE ARRONDO

IGNACIO SOLS

On congruences of lines in the projective space (Chapter 6 written in collaboration with M. Pedreira)

Mémoires de la S. M. F. 2^e série, tome 50 (1992)

<http://www.numdam.org/item?id=MSMF_1992_2_50_1_0>

© Mémoires de la S. M. F., 1992, tous droits réservés.

L'accès aux archives de la revue « Mémoires de la S. M. F. » (<http://smf.emath.fr/Publications/Memoires/Presentation.html>) implique l'accord avec les conditions générales d'utilisation (<http://www.numdam.org/conditions>). Toute utilisation commerciale ou impression systématique est constitutive d'une infraction pénale. Toute copie ou impression de ce fichier doit contenir la présente mention de copyright.

NUMDAM

Article numérisé dans le cadre du programme
Numérisation de documents anciens mathématiques

<http://www.numdam.org/>

Société Mathématique de France
Mémoire n° 50
Supplément au Bulletin de la S.M.F.
Tome 120, 1992, fascicule 3

ON CONGRUENCES OF LINES IN THE PROJECTIVE SPACE

by Enrique Arrondo and Ignacio Sols
(Chapter 6 written in collaboration with M. Pedreira)

RÉSUMÉ: Nous étudions les congruences lisses (c.a.d. les surfaces de la Grassmannienne $Gr(1,3)$ de droites de \mathbb{P}^3) en montrant leur parallélisme avec les surfaces de \mathbb{P}^4 . Après la description de toutes les congruences lisses de degré au plus neuf et l'étude de son schéma de Hilbert nous développons une théorie générale. Par exemple, nous définissons la notion de liaison adéquate aux congruences et classifions les congruences lisses qui sont projetées de $Gr(1,4)$. Nous trouvons aussi des majorations du genre sectionnel que nous utilisons pour obtenir des conditions (telles que d'avoir une caractéristique d'Euler-Poincaré donnée) qui ne sont vérifiées que par les congruences lisses d'un nombre fini de familles.

SUMMARY: We study smooth congruences (i.e., surfaces in the Grassmannian $Gr(1,3)$ of lines in \mathbb{P}^3) showing their parallelism with surfaces in \mathbb{P}^4 . Besides the description of all smooth congruences up to degree nine and studying their Hilbert scheme, we develop a general theory. For example, we define the adequate notion of liaison for congruences and classify the smooth congruences which are projected from $Gr(1,4)$. We also prove some bounds of the sectional genus in order to give conditions (e.g. having a fixed Euler-Poincaré characteristic) such that there are finitely many families of smooth congruences verifying those conditions.

Texte reçu le 21 août 1990, révisé le 17 juillet 1992
E. Arrondo, I.Sols, Departamento de Algebra, Facultad de Matematicas, Universidad Complutense,
28040 Madrid, Espagne

Table des Matières

	page
Introduction	3
0 - Preliminaries	7
1 - Vector bundles on $\text{Gr}(1,3)$	11
1.1 Generalities	
1.2 The universal vector bundles	
1.3 The vector bundles \hat{E}	
1.4 Some cohomology tables	
2 - Generalities on congruences	21
2.1 General properties of congruences	
2.2 A few words on the Hilbert scheme of congruences	
2.3 Correspondence between vector bundles and congruences	
Appendix	
2.4 Stability of the restriction of the universal bundles	
3 - Liaison of congruences	31
3.1 Spinor liaison of congruences	
3.2 Liaison equivalence classes	
3.3 Smooth congruences lying in a linear complex	
4 - Smooth congruences of low degree	43
4.1 Smooth congruences of degree at most eight	
4.2 Smooth congruences of degree nine	
Appendix	
4.3 Examples of other congruences	
4.4 Some known classification theorems for congruences	
5 - A projection theorem for smooth congruences	63
5.1 Some lemmas	
5.2 Proof of the theorem	
5.3 Smooth congruences with decomposable quotient bundle	
6 - Finiteness theorems for families of congruences (in collaboration with M. Pedreira)	73
6.1 Bounds for the genus of curves in Q_3	
6.2 Some technical lemmas	
6.3 Finiteness theorems	
References	93

INTRODUCTION

The present paper contains with almost no change the thesis of the first author, written under the advice of the second author.

The study of congruences of lines, i.e., surfaces in the Grassmann variety $G=Gr(1,3)$ of lines in \mathbb{P}^3 , goes back to the middle of last century. From that time, most of the classical algebraic geometers, such as Kummer, Reye, Schumacher, Bordiga, Corrado Segre, Castelnuovo, Fano, Jessop, Semple or Roth, have published papers devoted to this topic, classifying, under certain conditions, congruences of fixed degree or fixed order (see §0 for definitions) or just studying a particular congruence.

However, coinciding with the end of the classical algebraic geometry school, this flurry of research on congruences stopped suddenly. Only in the decade of the 80's, and parallel to the development of the theory of surfaces in \mathbb{P}^4 , a new interest for congruences started again. To our knowledge, the first paper of this second period (although published later than some other ones) is that of Ziv Ran ([37]) where, solving a conjecture proposed by Sols, he generalizes a classical result of Kummer and classifies all irreducible surfaces of order one in any Grassmannian. After this, many authors have published several papers on congruences: Cossec, Goldstein, Gross, Hernández, Papantopoulou, Verra, etc.

The reason why this resurgence of the theory of congruences coincides in time with the development of the theory of surfaces in \mathbb{P}^4 is that both G and \mathbb{P}^4 have the same dimension four (one less than the dimension of a natural ambient space for a smooth surface), so that the same kind of results are expected. In fact, any statement for surfaces in \mathbb{P}^4 has its analogous for congruences. The converse, however, is not true, since the geometry of congruences is much richer in problems. For example a congruence has a bidegree, instead of the degree of projective surfaces, and points of the congruence have an interpretation as lines in \mathbb{P}^3 .

The aim of this work is to prove some general statements on smooth congruences (mainly in §3, §5 and §6), most of them analogues of theorems for smooth surfaces in \mathbb{P}^4 . This does not mean that proofs are just a mere imitation of those for \mathbb{P}^4 . For example, Theorem 5.1, which is analogous to the Severi theorem in \mathbb{P}^4 , is proved by looking at the geometry of lines in \mathbb{P}^3 , so that not even a single idea of the proof of Severi is used. We also give in §4 a classification and description of the Hilbert scheme of smooth congruences of degree at most nine. At the end of §2 and §4, we add an appendix with partial results and conjectures, in order to show the numerous possibilities for future research with congruences.

The distribution of this work is as follows:

-In §0 we just give some preliminary definitions, as well as some general result that we will use frequently.

-We devote §1 to give general properties of vector bundles on G and we introduce the most important ones, that will be used later, especially in §4 to give resolutions of the ideal sheaves of congruences. We also give a new and shorter proof of the fact that the only indecomposable vector bundles on G not having intermediate cohomology are the line bundles and the twists of the universal bundles. This result, proved in algebraic terms by Knörrer (see [29]) with great generality, was independently proved for G by the second author by purely geometric means, but not published until he obtained a proof for all smooth quadrics (see [2]).

-In §2, after proving some known general results on congruences and several technical results that we will use to study the Hilbert scheme of congruences, we add an appendix where we prove some partial results related to a conjecture of Dolgachev on the semistability of the restriction to smooth congruences of the universal vector bundles.

-Section §3 consists of the development of a new theory of linkage for congruences. It is not exactly analogous to the known theory for projective varieties, since in our theory the role of complete intersections is played not only by them, but also by what we call spinor congruences (that are zero locus of sections of twists of the universal quotient bundle E_2^V). We show that our definition is the right one by proving analogous results to those for linkage in projective spaces. We prove, for example, that even liaison classes are in 1-1 correspondence with classes of vector bundles on G not having first cohomology spaces after tensoring with any line bundle and twists of E_2 (where two bundles are in the same class when they differ by a twist after removing their

components of the form $O_G(l)$ or $E_2(m)$). As an easy corollary of this theory, we get resolutions for the ideal sheaves of smooth congruences lying in a linear complex.

-In §4 we give a classification of smooth congruences of degree at most nine, giving a resolution of their ideal sheaves in G (thus providing a complete information on their cohomology, in particular we know the postulation of the congruences) and using it to describe their Hilbert scheme.

Section §4.1 corresponds to congruences of degree less than or equal to eight, whose classification is essentially due to Fano (see [11]) under different conditions. Also Papantonopoulou gives in [34] (with a slight mistake) a list of possible smooth congruences of degree at most eight (some members of her list actually do not exist). Our new contribution, besides giving the precise list of smooth congruences, is the description of their Hilbert scheme. These results appeared in [1]. New information on the restriction of the universal vector bundles to some of these congruences also appears in this section.

In section §4.2, devoted to smooth congruences of degree nine, something similar happens, since their classification was obtained by Verra (with a numerical mistake in the computation of the invariants of the one lying in a linear complex). We add as an appendix two more sections. In section §4.3 we selected several examples of more congruences (some of them in a quite incomplete way) and in section §4.4 we state some known results on congruences that we will need later or just that are interesting to get a global view of congruences).

-Section §5 contains a proof of what is the analogous for congruences of the Severi theorem in \mathbb{P}^4 . More precisely, we prove that, excepting an explicit list of five types of congruences, no other smooth congruence can be obtained as a projection of a surface in $Gr(1,4)$, the Grassmann variety of lines in \mathbb{P}^4 . We complete this section using this result to classify those smooth congruences such that the restriction to them of the universal quotient bundle decomposes as a direct sum of two line bundles.

-Finally, section §6 solves a conjecture of Robin Hartshorne made for both \mathbb{P}^4 and G , stating that only a finite number of families of smooth surfaces in these spaces correspond to rational surfaces. This problem was solved by Ellingsrud and Peskine for \mathbb{P}^4 (see [10]), proving a stronger result which has as an easy corollary that all but a finite number of families of smooth surfaces in \mathbb{P}^4 are of general type. Their result can be stated in several different ways, as Christian Peskine pointed out to us. In particular, we prove that there exists only a finite number of families of smooth

congruences S having a fixed Euler–Poincaré characteristic $\chi(\mathcal{O}_S)$.

Our proof is essentially a translation of theirs to G . The new and original part is mostly in section §6.1, where we obtain bounds for the genus of curves in Q_3 (hence for the sectional genus of congruences) depending on their postulation. Such a bound for curves in \mathbb{P}^3 was obtained by Gruson and Peskine by restricting to general plane sections and defining for it a series of ordered numbers which are each proved to differ by at most one with its neighbors. The solution for Q_3 is not so easy, and the trick that one has to use is to restrict not to smooth quadrics, but to quadratic cones, and define a series of ordered numbers that each differ by at most two with its neighbors. We also want to mention that the calculations in section §6.2 were made in collaboration with Manuel Pedreira.

We want to thank Christian Peskine for his continuous encouragement and help in the preparation of this work. We also shared useful conversations with G. Ellingsrud, K. Ranestad, A. Aure and A. Verra. We thank also M. Gross, who had us always informed on his progress in the topic, and also has helped a lot in correcting the grammar of the paper. Both authors have been supported by CAICYT grant PB86-0036 during the preparation of this work.

§0. PRELIMINARIES

We will denote with G the Grassmann variety $Gr(1,3)$ of lines in the projective space $\mathbb{P}^3 = \mathbb{P}(V)$ over \mathbb{C} . Via the Plücker embedding, we can also view G as a smooth quadric in $\mathbb{P}^5 = \mathbb{P}(\wedge^2 V)$. The Chow ring of G is very well-known, and we have

$-A^1(G) = \mathbb{Z}\eta_1$ where η_1 is the class of the hyperplane section of G in \mathbb{P}^5 . If the hyperplane is tangent at a point l of G , then its intersection with G is a cone with vertex l that corresponds to the Schubert cycle of lines of \mathbb{P}^3 that meet the line L represented by the point l . This is called a *special linear complex*. A hypersurface of G having class $d\eta_1$ in $A^1(G)$ is called a *complex of degree d* .

$-A^2(G) = \mathbb{Z}\eta_{2,1} \oplus \mathbb{Z}\eta_{2,2}$ where $\eta_{2,1}$ is the Schubert cycle of lines of \mathbb{P}^3 passing through a fixed point (also called an α -plane, since it is a plane inside \mathbb{P}^5) and $\eta_{2,2}$ is the Schubert cycle of lines of \mathbb{P}^3 contained in a fixed plane (also called a β -plane). Each plane of G is either an α -plane or a β -plane.

$-A^3(G) = \mathbb{Z}\eta_3$ where η_3 is the Schubert cycle of lines of \mathbb{P}^3 contained in a fixed plane and passing through a fixed point of the plane. This represents a line in \mathbb{P}^5 and, conversely, all lines of G admit such a geometric interpretation in \mathbb{P}^3 .

$-A^4(G) = \mathbb{Z}\eta_4$ where η_4 is, of course, the class of a point of G .

The multiplicative structure is given by

$$\begin{aligned} \eta_1^2 &= \eta_{2,1} + \eta_{2,2} \\ \eta_1 \eta_{2,1} &= \eta_3 \\ \eta_1 \eta_{2,2} &= \eta_3 \\ \eta_2 \eta_3 &= \eta_4 \\ \eta_{2,1}^2 &= \eta_4 \\ \eta_{2,2}^2 &= \eta_4 \end{aligned}$$

A cycle in $A^i(G)$ can, therefore, be denoted by an integer number, except for the case $i=2$, where we will use pairs of integers (a_1, a_2) to denote the class $a_1\eta_{2,1} + a_2\eta_{2,2}$. An element in the Chow ring of G will be written in polynomial form as

$$a_0 + a_1 t + (a_{2,1}, a_{2,2}) t^2 + a_3 t^3 + a_4 t^4$$

With this convention, since G is a quadric in \mathbb{P}^5 we can write its canonical line bundle as $\omega_G = \mathcal{O}_G(-4)$.

Notations. Throughout this work, we will use the following conventions:

An element of G will be denoted with a small latin letter (e.g. l) and the line in \mathbb{P}^3 it represents will be denoted by the corresponding capital letter (L in our example).

For any subvariety X of G , \mathcal{I}_X will denote the ideal sheaf of X in G .

If S be a smooth surface in G , we use the following notations for its invariants:

oThe *order* d_1 of S is defined to be the number of lines of the congruence passing through a fixed general point of \mathbb{P}^3 .

oThe *class* d_2 will be the number of lines of the congruence contained in a fixed general plane.

oWe will denote with d the *total degree* $d = d_1 + d_2 = H^2$ of S , that is its degree as a surface in \mathbb{P}^5 (H denotes the hyperplane class of S , i.e. the class of its intersection with a general linear complex).

oThe Euler-Poincaré characteristic of \mathcal{O}_S will be denoted by $\chi = 1 - q + p_g = 1 + p_a$, where $q = h^1(\mathcal{O}_S)$ is the *irregularity* of S , $p_g = h^2(\mathcal{O}_S)$ is the *geometric genus* and p_a is the *arithmetic genus*.

oWe use the symbol K to represent the canonical class of S

oWe denote by π the *sectional genus* of S , i.e., the genus of the intersection of S with a general linear complex. By the adjunction formula, $2\pi - 2 = H^2 + KH$.

There is an isomorphism $G(1, \mathbb{P}^3) \xrightarrow{\cong} Gr(1, \mathbb{P}^{3V})$ mapping each line in \mathbb{P}^3 into the pencil of planes containing the line. Hence, any congruence in $G(1, \mathbb{P}^3)$ of bidegree (d_1, d_2)

produces a congruence in $G(1, \mathbb{P}^{3V})$ of bidegree (d_2, d_1) with the same invariants. We will refer to this fact as *duality*.

Finally, we state here some general results that we will use several times throughout this work (in §4.4 we give a similar list of results concerning congruences, once the necessary ingredients are introduced).

[46] Proposition 1.1 (2). *Let X, Y, Z, S be smooth schemes appearing in a diagram*

$$\begin{array}{ccc} W & \longrightarrow & Y \\ h \downarrow & & \downarrow g \\ X & \xrightarrow{f} & Z \\ \pi \downarrow & & \\ S & & \end{array}$$

where $W = X \times_Z Y$ and f is a smooth map. Then, there is a dense open set U_1 in S such that for each s in U_1 the fiber W_s of $\pi \circ h$ (that is $X_s \times_Z Y$) is either empty or smooth. (The ground field here must have characteristic zero).

[23] Proposition 9.5. *A vector bundle F on \mathbb{P}^r is a direct sum of line bundles if and only if $H^i(F(l))=0$ for all integers l and $0 < i < r$.*

[31] Theorem 2. *Let V a complete normal variety of dimension at least two (over an algebraically closed field of characteristic zero) Let \mathcal{L} be an invertible sheaf on V such that, for large n , \mathcal{L}^n is spanned by its sections. Let these sections define the morphism $V \longrightarrow W$. Then, $H^1(\mathcal{L}^{-m}) = 0$ for all $m \geq 1$ if and only if $\dim(W) > 1$.*

The easy corollary we will apply is the following: Let \tilde{X} be the normalization of a projective surface X (in our case X will be a surface in a smooth quadric of \mathbb{P}^4). If we denote with $\mathcal{O}_{\tilde{X}}(1)$ to the pull-back to \tilde{X} of $\mathcal{O}_X(1)$, then $H^1(\mathcal{O}_{\tilde{X}}(-m)) = 0$ for all $m \geq 1$. (Just apply the above result making $\mathcal{L} = \mathcal{O}_{\tilde{X}}(1)$ and $n=1$).

We will also use a slight generalization of Mumford- Castelnuovo criterion (see Prop. 1.1).

§1. VECTOR BUNDLES ON $\text{Gr}(1,3)$

§1.1. Generalities.

We start with some general facts about vector bundles and coherent sheaves on G .

Let F be a coherent sheaf on G of rank r . According the convention given in §0, we can write its Chern classes as integers c_1 , $c_{2,1}$, $c_{2,2}$, c_3 and c_4 . Using the splitting principle one can check, for example that the twist $F(l)$ has Chern classes

$$\begin{aligned} c_1(F(l)) &= c_1 + rl \\ c_{2,1}(F(l)) &= c_{2,1} + (r-1)c_1 l + \binom{r}{2} l^2 \\ c_{2,2}(F(l)) &= c_{2,2} + (r-1)c_1 l + \binom{r}{2} l^2 \\ c_3(F(l)) &= c_3 + (r-2)(c_{2,1} + c_{2,2})l + 2 \binom{r-1}{2} c_1 l^2 + 2 \binom{r}{3} l^3 \\ c_4(F(l)) &= c_4 + (r-3)c_3 l + \binom{r-2}{2} (c_{2,1} + c_{2,2}) l^2 + 2 \binom{r-1}{3} c_1 l^3 + 2 \binom{r}{4} l^4 \end{aligned}$$

(here $\binom{a}{b}$ means $\frac{a(a-1)\dots(a-b+1)}{b!}$ even in case a is negative).

Also, we can deduce from the general Riemann-Roch theorem the characteristic $\chi(F)$ of F . Following [19] page 432 the Chern character of F is given by

$$\begin{aligned} ch(F) &= r + c_1 t + \frac{1}{2}(c_1^2 - 2c_{2,1}, c_1^2 - 2c_{2,2})t^2 + \frac{1}{6}(c_1^3 - 3c_1(c_{2,1} + c_{2,2}) + 3c_3)t^3 \\ &\quad + \frac{1}{24}(2c_1^4 - 4c_1^2(c_{2,1} + c_{2,2}) + 4c_1 c_3 + 2c_{2,1}^2 + 2c_{2,2}^2 - 4c_4)t^4 \end{aligned}$$

(This expression is given in [19] only for vector bundles, but it also holds for any coherent sheaf F since the Chern character is in fact defined on the Grothendieck group $K(G)$ of G).

On the other hand, the Chern polynomial of the tangent bundle \mathcal{T}_G of G can be calculated using the fact that G can be considered as a smooth hyperquadric in \mathbb{P}^5 , hence there are exact sequences

$$\begin{array}{ccccccc} 0 & \longrightarrow & \mathcal{T}_G & \longrightarrow & \mathcal{T}_{\mathbb{P}^5} \otimes \mathcal{O}_G & \longrightarrow & \mathcal{O}_G(2) \longrightarrow 0 \\ 0 & \longrightarrow & \mathcal{O}_G & \longrightarrow & \mathcal{O}_G(1)^6 & \longrightarrow & \mathcal{T}_{\mathbb{P}^5} \otimes \mathcal{O}_G \longrightarrow 0 \end{array}$$

that provide

$$c_t(\mathcal{T}_G) = 1 + 4t + (7,7)t^2 + 12t^3 + 6t^4$$

so that \mathcal{T}_G has Todd class

$$td(\mathcal{T}_G) = 1 + 2t + \left(\frac{23}{12}, \frac{23}{12}\right)t^2 + \frac{7}{3}t^3 + t^4$$

and applying the general Riemann-Roch theorem we obtain

$$\begin{aligned} \chi(F) &= \frac{c_1^4}{12} - \frac{c_1^2(c_{2,1} + c_{2,2})}{6} + \frac{c_1 c_3}{6} + \frac{c_{2,1}^2}{12} + \frac{c_{2,2}^2}{12} - \frac{c_4}{6} + \\ &\frac{2}{3} c_1^3 - c_1(c_{2,1} + c_{2,2}) + c_3 + \frac{23}{12} \left(c_1^2 - (c_{2,1} + c_{2,2}) \right) + \frac{7}{3} c_1 + r \end{aligned}$$

Another useful fact concerning coherent sheaves on G is the following analogous to the Mumford-Castelnuovo criterion.

Proposition 1.1. *If F is a coherent sheaf on G such that $h^i(F(-i))=0$ for $i=1,2,3,4$, then F is 0-regular, i.e., F is generated by its global sections and $h^i(F(-i+j))=0$ for $i=1,2,3,4$, and $j \geq 0$.*

Proof. We just consider F as a coherent sheaf on \mathbb{P}^5 and apply to it the Mumford-Castelnuovo criterion for \mathbb{P}^5 . The only new vanishing we have to check is $h^5(F(-5))=0$, that is trivial since F is supported on a scheme of dimension at most four. ■

This proof shows that Mumford-Castelnuovo criterion is valid for coherent sheaves on any projective variety X , just by considering them as coherent sheaves on the projective space in which X lies. This fact will be used in §6.

§1.2. The universal vector bundles.

Let \mathcal{X} be the subvariety of $G \times \mathbb{P}^3$ corresponding to those pairs (l, x) such that the point x belongs to the line L defined by l . We denote with p and q the natural projections to G and \mathbb{P}^3 . If we consider the Euler sequence of \mathbb{P}^3

$$0 \longrightarrow \Omega_{\mathbb{P}^3}(1) \longrightarrow H^0(\mathcal{O}_{\mathbb{P}^3}(1)) \otimes \mathcal{O}_{\mathbb{P}^3} \longrightarrow \mathcal{O}_{\mathbb{P}^3}(1) \longrightarrow 0$$

and then pull it back to \mathcal{X} by q and take its direct image under p we obtain the universal exact sequence in $G = \text{Gr}(1,3)$

$$0 \longrightarrow E_1 \longrightarrow H^0(\mathcal{O}_{\mathbb{P}^3}(1)) \otimes \mathcal{O}_G \longrightarrow E_2^\vee \longrightarrow 0$$

where E_1 and E_2 are vector bundles of rank two and Chern classes $c_1(E_1) = c_1(E_2) = -1$, $c_2(E_1) = (1,0)$, $c_2(E_2) = (0,1)$. In particular, $E_1^\vee = E_1(1)$ and $E_2^\vee = E_2(1)$. Also, the cotangent bundle Ω_G of G is known to be the tensor product $E_1 \otimes E_2$ of these bundles.

The reason for our notation E_1 and E_2 for the universal bundles is that, if we dualize the above sequence, we obtain the universal sequence for the Grassmann variety of lines in \mathbb{P}^{3V} and E_1 and E_2 permute their roles.

Taking cohomology in the universal sequence, we obtain

$$H^0(E_2^\vee) = H^0(\mathcal{O}_{\mathbb{P}^3}(1)) = V$$

and get that sections of E_2^\vee corresponds bijectively with β -planes. More precisely, each section s of E_2^\vee vanishes exactly on a β -plane X_2 and we have a Koszul exact sequence

$$0 \longrightarrow \mathcal{O}_G \xrightarrow{s} E_2^\vee \longrightarrow \mathcal{J}_{X_2}(1) \longrightarrow 0$$

Dually, sections of E_1^\vee correspond to α -planes.

From this Koszul sequence, we easily obtain

$$\begin{aligned} h^1(E_2) &= h^1(\mathcal{J}_{X_2}) = 0 \\ h^2(E_2(-1)) &= h^2(\mathcal{J}_{X_2}(-1)) = h^1(\mathcal{O}_{\mathbb{P}^2}(-1)) = 0 \\ h^3(E_2(-2)) &= h^3(\mathcal{J}_{X_2}(-2)) = h^2(\mathcal{O}_{\mathbb{P}^2}(-2)) = 0 \end{aligned}$$

$$h^4(E_2(-3)) = h^4(\mathcal{J}_{X_2}(-3)) = h^3(\mathcal{O}_{X_2}(-3)) = 0$$

Thus, applying Prop. 1.1 one gets that $h^i(E_2(1-i+j)) = 0$ for all $j \geq 0$ and $i=1,2,3,4$. Using Serre's duality and the fact that $E_2^\vee = E_2(1)$ we conclude that $H^i(E_2(l))=0$ for $i=1,2,3$ and $l \in \mathbb{Z}$. We will refer to this by saying that E_2 has not intermediate cohomology.

By duality, we also obtain that E_1 has no intermediate cohomology. Clearly, the trivial bundle \mathcal{O}_G also has no intermediate cohomology. We will prove next that this property characterizes (up to a twist) these three (indecomposable) bundles.

Proposition 1.2 (Ottaviani [32]). *Let F be a vector bundle on G . Then, the following are equivalent:*

- (i) F has no intermediate cohomology and $H^1(F \otimes E_j(l))=0$ for $j=1,2$ and $l \in \mathbb{Z}$.
- (ii) F has no intermediate cohomology and $H^i(F \otimes E_1(l))=0$ for $i=1,2$ and $l \in \mathbb{Z}$
- (iii) F is a direct sum of line bundles.

Proof. (i) and (ii) are clearly equivalent since $H^2(F \otimes E_1(l)) = H^1(F \otimes E_2(l+1))$ after tensoring the universal exact sequence with $F(l)$ and taking cohomology. It is also immediate that a direct sum of line bundles verifies both (i) and (ii).

Therefore, we assume that (ii) holds for F and will prove it is a sum of line bundles. We consider a general α -plane X_1 and its associated Koszul exact sequence

$$0 \longrightarrow \mathcal{O}_G \longrightarrow E_1^\vee \longrightarrow \mathcal{O}_G(1) \longrightarrow \mathcal{O}_{X_1}(1) \longrightarrow 0$$

that, after tensoring with F , tells us that $F \otimes \mathcal{O}_{X_1}$ has no intermediate cohomology in $X_1 \cong \mathbb{P}^2$. Applying Horrocks' theorem to it (see [23] Prop. 9.5, or [4] Lemma 1 page 334 for a proof closer to ours), we conclude that $F \otimes \mathcal{O}_{X_1}$ is a direct sum of line bundles $\bigoplus_{i=0}^r \mathcal{O}_{X_1}(a_i)$. Denote by P the corresponding sum in G , i.e. $P = \bigoplus_{i=0}^r \mathcal{O}_G(a_i)$. Tensoring the above Koszul sequence with $P^\vee \otimes F$ and taking cohomology we obtain an epimorphism (since its cokernel is zero from our assumptions on the cohomology vanishing)

$$\text{Hom}(P, F) \longrightarrow \text{Hom}(P \otimes \mathcal{O}_{X_1}, F \otimes \mathcal{O}_{X_1})$$

that provides a morphism $P \xrightarrow{\varphi} F$ whose restriction to X_1 is an isomorphism. We conclude

that φ itself is an isomorphism. Indeed, since φ fails to be isomorphic in the zero locus of its determinant, that is a homogeneous form in \mathbb{P}^5 . If its degree is positive, then this locus should meet X_1 , that is absurd. Therefore, φ has a non-zero constant as determinant and thus is an isomorphism, as wanted. \blacksquare

Proposition 1.3. *Let F be an indecomposable vector bundle not having intermediate cohomology. Then F is a twist with a line bundle of either \mathcal{O}_G or E_1 or E_2 .*

Proof. By considering all non-zero spaces $H^1(F \otimes E_j(l))$ we get an extension

$$0 \longrightarrow F \xrightarrow{\varphi} P \xrightarrow{\psi} \left(\bigoplus_{i=1}^r E_1^\vee(a_i) \right) \otimes \left(\bigotimes_{k=1}^s E_2^\vee(b_k) \right) \longrightarrow 0$$

where P is a bundle verifying (i) in Prop. 1.2. Therefore, P is a sum of line bundles. We consider the following commutative diagram of exact sequences

$$\begin{array}{ccccccc} & & 0 & & 0 & & \\ & & \downarrow & & \downarrow & & \\ 0 & \longrightarrow & F & \longrightarrow & P & \longrightarrow & \left(\bigoplus_{i=1}^r E_1^\vee(a_i) \right) \otimes \left(\bigotimes_{k=1}^s E_2^\vee(b_k) \right) \longrightarrow 0 \\ & & \downarrow & & \downarrow & & \parallel \\ 0 & \longrightarrow & K & \longrightarrow & P \otimes P' & \xrightarrow{(\psi, \rho)} & \left(\bigoplus_{i=1}^r E_1^\vee(a_i) \right) \otimes \left(\bigotimes_{k=1}^s E_2^\vee(b_k) \right) \longrightarrow 0 \\ & & \downarrow & & \downarrow & & \\ & & P' & \xlongequal{\quad} & P' & & \\ & & \downarrow & & \downarrow & & \\ & & 0 & & 0 & & \end{array}$$

where P' is the sum of line bundles $\left(\bigoplus_{i=1}^r \mathcal{O}_G^4(a_i) \right) \otimes \left(\bigotimes_{k=1}^s \mathcal{O}_G^4(b_k) \right)$ and the morphism ρ is the natural one defined from the universal exact sequence and its dual after twisting with the a_i 's and the b_k 's. The kernel K of (ψ, ρ) appears in another diagram

$$\begin{array}{ccccccc} & & 0 & & 0 & & \\ & & \downarrow & & \downarrow & & \\ 0 & \longrightarrow & \left(\bigoplus_{i=1}^r E_2^\vee(a_i) \right) \otimes \left(\bigotimes_{k=1}^s E_1^\vee(b_k) \right) & \longrightarrow & P' & \xrightarrow{\rho} & \left(\bigoplus_{i=1}^r E_1^\vee(a_i) \right) \otimes \left(\bigotimes_{k=1}^s E_2^\vee(b_k) \right) \longrightarrow 0 \\ & & \downarrow & & \downarrow & & \parallel \\ 0 & \longrightarrow & K & \longrightarrow & P \otimes P' & \xrightarrow{(\psi, \rho)} & \left(\bigoplus_{i=1}^r E_1^\vee(a_i) \right) \otimes \left(\bigotimes_{k=1}^s E_2^\vee(b_k) \right) \longrightarrow 0 \\ & & \downarrow & & \downarrow & & \\ & & P & \xlongequal{\quad} & P & & \\ & & \downarrow & & \downarrow & & \\ & & 0 & & 0 & & \end{array}$$

that proves, since the universal bundles have no intermediate cohomology, that $K =$

$P \otimes (\bigoplus_{i=1}^r E_2(a_i)) \otimes (\bigotimes_{k=1}^s E_1(b_k))$. On the other hand, from the first diagram and the fact that F has no intermediate cohomology we also conclude that $K = P' \otimes F$. Since the decomposition must be unique, we conclude our result. ■

This result was already known for any smooth quadric (see [29], [6] or [5]) but we have given here a simpler proof. For a similar argument for all smooth quadrics see [2].

§1.3. The vector bundles \dot{E} .

We will now introduce another important rank two vector bundle on G (a family of bundles, to be more precise). Our construction is not the usual one (requiring the techniques in §2.3). The main reason for us to use this new construction is that it allows us to relate the bundles \dot{E} with the bundles \mathcal{V} introduced in [21].

First, we pick two sections s_1 and s_2 of E_1^V and E_2^V respectively such that they define disjoint α and β -planes (i.e., the point defining the α -plane is not in the plane defining the β -plane). Thus, the induced section of $E_1^V \otimes E_2^V$ does not vanish at any point of G , defining a rank three vector bundle appearing as a quotient in an exact sequence

$$0 \longrightarrow \mathcal{O}_G \longrightarrow E_1^V \otimes E_2^V \longrightarrow \mathcal{V}(1) \longrightarrow 0$$

(we write the bundle $\mathcal{V}(1)$ with a twist to preserve the notation in [21]). Applying the results in §1.1 we see that \mathcal{V} has Chern classes $c_1 = -1$, $c_2 = (1, 1)$ and $c_3 = 0$. If we dualize this sequence and tensor with $\mathcal{O}_G(1)$ we get

$$0 \longrightarrow \mathcal{V}^V \longrightarrow E_1^V \otimes E_2^V \longrightarrow \mathcal{O}_G(1) \longrightarrow 0$$

(showing in particular that the sequence is not split and $h^1(\mathcal{V}^V(-1)) = 1$, since $E_1 \otimes E_2$ has not sections).

Taking global sections, the map $H^0(E_1^V \otimes E_2^V) \longrightarrow H^0(\mathcal{O}_G(1))$ is given by $(t_1, t_2) \longmapsto s_1 \wedge t_1 + s_2 \wedge t_2$ (that is surjective), so that we conclude that the pencil of sections of $H^0(E_1^V \otimes E_2^V)$ that come from sections of \mathcal{V}^V are of the form $(\lambda s_1, \mu s_2)$, with $\lambda, \mu \in \mathbb{C}$. Hence, no section of \mathcal{V}^V vanishes at any point of G and again we obtain an exact sequence

$$0 \longrightarrow \mathcal{O}_G \longrightarrow \mathcal{V}^V \longrightarrow \dot{E}(1) \longrightarrow 0$$

where \dot{E} is now a rank two vector bundle of Chern classes $c_1=-1$ and $c_2=(1,1)$. We see that $h^0(\dot{E}(1)) = h^0(V^\vee)-1 = 1$ and $h^0(\dot{E}) = h^0(V^\vee(-1)) = 0$. Hence, the only section of $\dot{E}(1)$ should vanish on a surface \dot{X} providing a Koszul exact sequence

$$0 \longrightarrow \mathcal{O}_G \longrightarrow \dot{E}(1) \longrightarrow \mathcal{I}_{\dot{X}}(1) \longrightarrow 0$$

so that we deduce that $h^1(\mathcal{I}_{\dot{X}}) = h^1(\dot{E}) = h^1(V^\vee(-1)) = 1$ and thus \dot{X} has two connected components. Therefore, \dot{X} (that is a (1,1) congruence) is the disjoint union of an α -plane and a β -plane. Moreover, these planes are those defined by s_1 and s_2 . Indeed, we have a commutative diagram

$$\begin{array}{ccccccc} & & 0 & & 0 & & \\ & & \downarrow & & \downarrow & & \\ & & \mathcal{O}_G & \xlongequal{\quad} & \mathcal{O}_G & & \\ & & \downarrow & & \downarrow & & \\ 0 & \longrightarrow & \mathcal{O}_G^2 & \longrightarrow & V^\vee & \longrightarrow & \mathcal{I}_{\dot{X}}(1) \longrightarrow 0 \\ & & \downarrow & & \downarrow & & \parallel \\ 0 & \longrightarrow & \mathcal{O}_G & \longrightarrow & \dot{E}(1) & \longrightarrow & \mathcal{I}_{\dot{X}}(1) \longrightarrow 0 \\ & & \downarrow & & \downarrow & & \\ & & 0 & & 0 & & \end{array}$$

showing that \dot{X} is the locus where the morphism $\mathcal{O}_G^2 \longrightarrow V^\vee$ is not an inclusion of bundles. As remarked above, if we compose this morphism with the inclusion $V^\vee \longrightarrow E_1^\vee \otimes E_2^\vee$ we obtain the morphism $\mathcal{O}_G^2 \longrightarrow E_1^\vee \otimes E_2^\vee$ given by the sections $(s_1, 0)$ and $(0, s_2)$ of $E_1^\vee \otimes E_2^\vee$, which fails to be an inclusion of bundles exactly where either s_1 or s_2 vanishes.

Conversely, any rank two bundle \dot{E} such that a section of $\dot{E}(1)$ vanishes on the disjoint union \dot{X} of an α -plane and a β -plane can be constructed as above. Indeed, from the above Koszul sequence we can compute the cohomology of \dot{E} and in particular one sees that

$$\begin{aligned} h^1(\dot{E}) &= h^1(\mathcal{I}_{\dot{X}}) = 1 \\ h^1(\dot{E}(l)) &= h^1(\mathcal{I}_{\dot{X}}(l)) = 0 \text{ for any } l \neq 0 \\ h^2(\dot{E}(l)) &= h^2(\mathcal{I}_{\dot{X}}(l)) = h^1(\mathcal{O}_{X_1}(l)) + h^1(\mathcal{O}_{X_2}(l)) = 0 \text{ for any } l \\ h^3(\dot{E}(l)) &= 0 \text{ for } l \neq -3 \text{ and } h^3(\dot{E}(-3)) = 1 \text{ (by Serre duality)} \end{aligned}$$

Therefore there is an extension in $Ext^1(\dot{E}(1), \mathcal{O}_G) = H^1(\dot{E})$ that provides an exact sequence

$$0 \longrightarrow \mathcal{O}_G \longrightarrow F \longrightarrow \dot{E}(1) \longrightarrow 0$$

where F is a rank three bundle whose only intermediate cohomology is $h^1(F(-1))=1$ (since $H^3(\dot{E}(-3)) \longrightarrow H^4(\mathcal{O}_G(-1))$ is the dual of the isomorphism $H^0(\mathcal{O}_G) \longrightarrow H^1(\dot{E})$ corresponding to the non-trivial extension). This yields an extension in $Ext^1(F^\vee(1), \mathcal{O}_G)$

$$0 \longrightarrow \mathcal{O}_G \longrightarrow F' \longrightarrow F^\vee(1) \longrightarrow 0$$

and now F' is a rank four bundle not having intermediate cohomology, so that applying Prop. 1.2 and looking at the cohomology and Chern classes of F' , one concludes that $F' = E_1^\vee \otimes E_2^\vee$ and then $F = V^\vee$.

Therefore we conclude that the moduli space of these bundles \dot{E} is isomorphic to the open subset U of $\mathbb{P}^3 \times \mathbb{P}^{3V}$ obtained by removing the incidence variety. In particular, this moduli space is smooth, rational, irreducible and has dimension six.

There is also a universal vector bundle $\dot{\mathcal{E}}$ on this moduli space constructed as follows. Consider the subvariety \mathcal{Y} of $G \times G \times U$ consisting of those (m, l, x, Π) such that

$$\begin{aligned} x &\in M \text{ or } M \subseteq \Pi \\ L \cap M &\neq \emptyset \\ x &\in \langle L, M \rangle \\ L \cap M &\subseteq \Pi \end{aligned}$$

and consider its projection π on $G \times U$. We study the possible different fibers of π on elements (l, x, Π) depending on the position of x and Π with respect to L .

If the line L neither passes through the point x and nor is contained in the plane Π , then there are two elements in the fiber, namely the line joining the points x and $\Pi \cap L$, and the line obtained by the intersection of the planes Π and the span of x and L .

If the point x is in L , then the fiber consists of the pencil of those lines contained in Π and passing through $L \cap \Pi$.

If the plane Π contains L , then the fiber is the pencil of lines passing through x and contained in the plane spanned by x and L .

This proves in particular that \mathcal{Y} is connected. If p is the projection from $G \times U$ onto G then we define $\dot{\mathcal{E}}$ to be $\pi_* \mathcal{O}_{\mathcal{Y}} \otimes p^* \mathcal{O}_G(-1)$. This is a rank two vector bundle on $G \times U$ since

the fiber of $\pi_* \mathcal{O}_{\mathcal{Y}} \otimes \mathcal{P}^* \mathcal{O}_G(1)$ in each point (l, x, Π) is a two-dimensional vector space in any of the three possible cases (namely the direct sum of the base fields of the two points of G in the first case above, and $H^0(\mathcal{O}_{\mathbb{P}^1}(1))$ in the other two cases, where \mathbb{P}^1 denotes the corresponding pencil of lines).

There is a canonical section (unique since \mathcal{Y} is connected) $\mathcal{O}_{G \times U} \longrightarrow \pi_* \mathcal{O}_{\mathcal{Y}} = \mathcal{E} \otimes \mathcal{P}^* \mathcal{O}_G(1)$ that vanishes on the subscheme $\dot{\mathcal{X}}$ of \mathcal{Y} consisting of the disjoint union of \mathcal{X}_1 and \mathcal{X}_2 where \mathcal{X}_1 is the subvariety of \mathcal{Y} of those (l, x, Π) such that the point x lies in the line L and \mathcal{X}_2 corresponds to those (l, x, Π) such that the line L is contained in the plane Π .

§1.4 Some cohomology tables.

Once we know that the universal bundles have no intermediate cohomology, we can easily calculate their cohomology by just applying Riemann-Roch theorem. Thus, one gets the following table

$i \quad l$	-5	-4	-3	-2	-1	0	1	2	$h^i(E_1(l)) = h^i(E_2(l))$
4	20	4	0	0	0	0	0	0	
3	0	0	0	0	0	0	0	0	
2	0	0	0	0	0	0	0	0	
1	0	0	0	0	0	0	0	0	
0	0	0	0	0	0	0	4	20	

Recalling from §1.3 that the only intermediate cohomology of \dot{E} is $h^1(\dot{E}) = h^3(\dot{E}(-3)) = 1$, we can apply Riemann-Roch to obtain the following table

$i \quad l$	-5	-4	-3	-2	-1	0	1	2	$h^i(\dot{E}(l))$
4	14	1	0	0	0	0	0	0	
3	0	0	1	0	0	0	0	0	
2	0	0	0	0	0	0	0	0	
1	0	0	0	0	0	1	0	0	
0	0	0	0	0	0	0	1	14	

Using the exact sequences

$$0 \longrightarrow \Omega_{\mathbb{P}^3} \otimes \mathcal{O}_G(-1) \longrightarrow \wedge^2 \mathcal{N} \otimes \mathcal{O}_G \longrightarrow \mathcal{O}_G(1) \longrightarrow 0$$

$$0 \longrightarrow \mathcal{O}_G(-2) \longrightarrow \Omega_{\mathbb{P}^3} \otimes \mathcal{O}_G \longrightarrow \Omega_G = E_1 \otimes E_2 \longrightarrow 0$$

one obtains

i	l	-5	-4	-3	-2	-1	0	1	2
4		64	15	0	0	0	0	0	0
3		0	0	0	1	0	0	0	0
2		0	0	0	0	0	0	0	0
1		0	0	0	0	0	1	0	0
0		0	0	0	0	0	0	0	15

$$h^i(E_1 \otimes E_2(l))$$

Finally, using the above table and the universal sequence tensored with E_1

$$0 \longrightarrow E_1 \otimes E_1 \longrightarrow V \otimes E_1 \longrightarrow E_1 \otimes E_2(1) \longrightarrow 0$$

and recalling that $E_1 \otimes E_1 = \mathcal{O}_G(-1) \otimes S^2 E_1$ we can write down the following table

i	l	-5	-4	-3	-2	-1	0	1	2
4		45	10	0	0	0	0	0	0
3		0	0	0	0	0	0	0	0
2		0	0	0	0	1	0	0	0
1		0	0	0	0	0	0	0	0
0		0	0	0	0	0	0	0	10

$$h^i(S^2 E_1(l)) = h^i(S^2 E_2(l))$$

§2. GENERALITIES ON CONGRUENCES

§2.1. General properties of congruences.

Let X be a smooth variety. To give a morphism f from X to G is equivalent to giving a rank two vector bundle E on X together with an epimorphism $O_X^4 \xrightarrow{\varphi} E$. This epimorphism φ turns out to be the pull-back by f of the canonical morphism $H^0(O_{\mathbb{P}^3}(1)) \otimes O_G \longrightarrow E_2^V$. The condition for f to be an immersion is that any subscheme of length two of X imposes at least three conditions to the subspace of sections of $H^0(E)$ defined by φ (i.e., different points of X , are mapped by f to different lines, since their span in \mathbb{P}^3 is at least a plane, and analogously, infinitely near points map to infinitely near lines).

In the case when we have an embedding of a smooth surface S in G , then we have that the class d_2 of the congruence is the second Chern class of $E_2^V \otimes O_S$ and its order d_1 is analogously the second Chern class of $E_1^V \otimes O_S$.

Definition. If there are more than d_1 lines of a congruence passing through a point, then an infinity of them pass through that point. Such a point is called a *singular point* of the congruence. Dually, a plane of \mathbb{P}^3 that contains infinitely many lines of the congruence is called a *singular plane*. If it exists (cf. Prop. 4.4), a curve of \mathbb{P}^3 consisting of singular points of the congruence is called a *fundamental curve*.

As it happens for smooth surfaces in \mathbb{P}^4 (cf. [19] page 434), the invariants of a smooth congruence satisfy a numerical relation, which is very well known (cf. [33], [22] or [47]). We prove it below.

Proposition 2.1. *Let S be a smooth congruence. Then its invariants verify the following relation*

$$d_1^2 + d_2^2 = 3d + 4(2\pi - 2) + 2K^2 - 12\chi$$

Proof. The first term of the equality is the self intersection of S , so that it is the second Chern class of the normal bundle N of S in G . We compute this Chern class now using the exact sequence

$$0 \longrightarrow \mathcal{I}_S \longrightarrow \mathcal{I}_G \otimes \mathcal{O}_S \longrightarrow N \longrightarrow 0$$

The Chern polynomials of the first two vector bundles appearing in the sequence are

$$c_t(\mathcal{I}_S) = 1 - Kt + c_2(\mathcal{I}_S)$$

$$c_t(\mathcal{I}_G \otimes \mathcal{O}_S) = 1 + 4Ht + (7d_1 + 7d_2)t^2$$

(the last one obtained by restricting to S the Chern polynomial of \mathcal{I}_G obtained in Ch. 1), so that N has Chern polynomial

$$c_t(N) = 1 + (K + 4H)t + (7d_1 + 7d_2 + 4KH - c_2(\mathcal{I}_S) + K^2)t^2$$

The result follows now from the adjunction formula, as well as from Nöther's formula $\chi = \frac{c_2(\mathcal{I}_S) + K^2}{12}$. ■

We now calculate the relation between the invariants of a smooth congruence S and the Chern classes of its ideal sheaf \mathcal{I}_S , which will be very useful throughout this work.

Clearly we have $c_1(\mathcal{I}_S) = 0$. Also, since S is locally Cohen-Macaulay, \mathcal{I}_S has homological dimension one, so that it has a resolution of the form

$$0 \longrightarrow F_1 \xrightarrow{\sigma} F_0 \longrightarrow \mathcal{I}_S \longrightarrow 0$$

where F_1 and F_0 are locally free. The morphism σ fails to be an inclusion of bundles exactly at the scheme S , that has the expected codimension two. Hence, from Porteous formula, $c_2(\mathcal{I}_S) = (d_1, d_2)$. Let us denote with c_3 and c_4 the numbers representing the third and fourth Chern classes of \mathcal{I}_S . Using the results of §1.1 we have for all integers l that

$$c_1(\mathcal{I}_S(l)) = l$$

$$c_2(\mathcal{I}_S(l)) = (d_1, d_2)$$

$$c_3(\mathcal{J}_S(l)) = c_3 - dl$$

$$c_4(\mathcal{J}_S(l)) = c_4 - 2c_3 l + dl^2$$

and, hence, applying Riemann-Roch for coherent sheaves in G we get

$$\chi(\mathcal{J}_S(l)) = \frac{l^4}{12} + \frac{2l^3}{3} + (\frac{23}{12} - \frac{d}{2})l^2 + (\frac{1}{2}c_3 - 2d + \frac{7}{3})l + c_3 + \frac{d_1^2 + d_2^2}{12} - \frac{1}{6}c_4 - \frac{23d}{12} + 1$$

and, on the other hand,

$$\chi(\mathcal{J}_S(l)) = \chi(\mathcal{O}_G(l)) - \chi(\mathcal{O}_S(l)) = \binom{l+5}{5} - \binom{l+3}{5} - \chi - \frac{l^2 d - lKH}{2} =$$

$$\frac{l^4}{12} + \frac{2l^3}{3} + (\frac{23}{12} - \frac{d}{2})l^2 + (\frac{7}{3} - \frac{d}{2} + \pi - 1)l + 1 - \chi$$

Therefore, identifying the coefficients of terms of same degree, we get

$$c_3 = 3d + 2\pi - 2$$

$$c_4 = \frac{15}{2}d + \frac{d^2 + d^2}{2} + 6(2\pi - 2) + 6\chi = 8d + 8(2\pi - 2) + 6\chi^2$$

where the last equality comes from Prop. 2.1.

Lemma 2.2. *Let S be a smooth congruence. Then, the general intersection of S with a special linear complex is a smooth curve.*

Proof. Let I be the incidence correspondence in $G \times G^V$ (where the dual G^V of G means the space of special linear complexes of G) and let p and q be the natural projections to G and G^V . Consider the subscheme V of I consisting of couples (l, H) where H is the special linear complex defined by the line l and let $\pi: \tilde{I} \rightarrow I$ be the blow-up of I along V . We define \tilde{p} and \tilde{q} to be the composition of p and q with π .

Fibers of \tilde{q} are just blow-ups of the special linear complexes along their singular point, hence smooth. We are thus in the hypothesis of [46] Prop. 1.1 (2), so that we conclude that the fiber product over G of S and the general fiber of \tilde{q} is smooth. This fiber product is isomorphic to the intersection of S with the corresponding special linear complex H , since the singular point of a general H is not in S . ■

§2.2. A few words on the Hilbert scheme of congruences.

The expected dimension for the component of the Hilbert scheme where a smooth congruence S lies in, will be given by the Euler-Poincaré characteristic of its normal bundle N . For calculating this expected dimension, we just apply the Riemann-Roch theorem for a vector bundle F on S , which says

$$\chi(F) = \text{rank}(F)\chi + \frac{1}{2}c_1(F)^2 - \frac{1}{2}c_1(F)K - c_2(F)$$

that gives in our case (recalling the Chern polynomial from of N from the proof of above Prop. 2.1)

$$\chi(N) = 6d_1 + 6d_2 - d_1^2 - d_2^2 + 2(2\pi - 2) + 2\chi$$

We have the following criteria for the vanishing of $H^1(N)$ and $H^2(N)$.

Lemma 2.3. *Let S be a locally complete intersection surface in G . Then, $H^i(N) = \text{Ext}^{i+1}(\mathcal{I}_S, \mathcal{I}_S)$ for $i=1,2,3$ and we have*

$$a) \text{ If } p_g = 0 \text{ then } H^2(N) = 0$$

$$b) \text{ If } q_g = 0 \text{ then } H^1(N) = 0$$

In particular, each component of the Hilbert scheme consisting of smooth rational congruences is smooth and has the expected dimension $6d_1 + 6d_2 - d_1^2 - d_2^2 + 2(2\pi - 2) + 2\chi$.

Proof. For the first part we just repeat the argument for curves in \mathbb{P}^3 made in the proof of Prop. 4.2 in [20]. We consider the spectral sequence for local and global Ext given by $E_2^{p,q} = H^p(\mathcal{E}xt^q(\mathcal{I}_S, \mathcal{I}_S)) \Rightarrow E_n = \text{Ext}^n(\mathcal{I}_S, \mathcal{I}_S)$. We observe that this spectral sequence is degenerate, and more precisely

$$E_2^{0,0} = H^0(\mathcal{O}_G) = \mathbb{C}$$

$$E_2^{p,0} = H^p(\mathcal{O}_G) = 0 \text{ for } p > 0$$

$$E_2^{p,1} = H^p(\mathcal{E}xt^1(\mathcal{I}_S, \mathcal{I}_S))$$

$$E_2^{p,q} = 0 \text{ for } q > 1$$

the last vanishing coming from the fact that \mathcal{I}_S has homological dimension one.

To conclude the first part of our assertion we just have to show that $\mathcal{E}xt^1(\mathcal{I}_S, \mathcal{I}_S) = N$.

Applying the functor $\mathcal{H}om(\mathcal{I}_S, -)$ to the exact sequence

$$0 \longrightarrow \mathcal{I}_S \longrightarrow \mathcal{O}_G \longrightarrow \mathcal{O}_S \longrightarrow 0$$

and recalling that \mathcal{I}_S has homological dimension one, we obtain a long exact sequence

$$\begin{array}{ccccccc}
 0 & \longrightarrow & \mathcal{H}om(\mathcal{I}_S, \mathcal{I}_S) & \xrightarrow{\alpha} & \mathcal{H}om(\mathcal{I}_S, \mathcal{O}_G) & \longrightarrow & \mathcal{H}om(\mathcal{I}_S, \mathcal{O}_S) \\
 & & & & & & \downarrow \\
 & & & & & & \mathcal{E}xt^1(\mathcal{I}_S, \mathcal{O}_S) \\
 & & & & & & \downarrow \\
 & & & & & & 0
 \end{array}$$

$$\begin{array}{ccccccc}
 & & & & & & \downarrow \\
 & & & & & & \mathcal{E}xt^1(\mathcal{I}_S, \mathcal{I}_S) \\
 & & & & & & \downarrow \\
 & & & & & & 0
 \end{array}$$

What we need to show is that α and β are isomorphisms, since then $\mathcal{E}xt^1(\mathcal{I}_S, \mathcal{I}_S) = \mathcal{H}om(\mathcal{I}_S, \mathcal{O}_S) = \mathcal{H}om(\mathcal{I}_S \otimes_{\mathcal{O}_S}, \mathcal{O}_S) = \mathcal{H}om(N^\vee, \mathcal{O}_S) = N$. This is a local question and, since S is locally a complete intersection we can assume, by restricting to a suitable open subscheme of G , that we have an exact sequence

$$0 \longrightarrow \mathcal{O}_G \xrightarrow{(f, g)} \mathcal{O}_G \otimes \mathcal{O}_G \xrightarrow{(g, -f)} \mathcal{I}_S \longrightarrow 0$$

so that we reduce our problem to a problem of commutative algebra.

Suppose first that we have a morphism $\varphi: \mathcal{I}_S \longrightarrow \mathcal{O}_G$ and denote $F = \varphi(f)$, $G = \varphi(g)$. Then, $gF - fG = 0$ in \mathcal{I}_S , so that there exists an H in \mathcal{O}_G such that $F = fH$ and $G = gH$ (from the above exact sequence). This proves that the image of φ is in the ideal \mathcal{I}_S (since it is generated by f and g). Therefore, α is epimorphism and hence isomorphism.

On the other hand, assume we have an extension ξ in $\mathcal{E}xt^1(\mathcal{I}_S, \mathcal{O}_G)$ that goes to zero in $\mathcal{E}xt^1(\mathcal{I}_S, \mathcal{O}_S)$. In other words, there is a diagram

$$\begin{array}{ccccccc}
 & & 0 & & 0 & & \\
 & & \downarrow & & \downarrow & & \\
 & & \mathcal{I}_S & \xlongequal{\quad} & \mathcal{I}_S & & \\
 & & \downarrow & & \zeta \downarrow & & \\
 \xi: & 0 & \longrightarrow & \mathcal{O}_G & \xrightarrow{i} & M & \xrightarrow{p} & \mathcal{I}_S & \longrightarrow & 0 \\
 & & & \downarrow & & \varphi \downarrow & & \parallel & & \\
 \xi': & 0 & \longrightarrow & \mathcal{O}_S & \xrightarrow{j} & M' & \xrightarrow{q} & \mathcal{I}_S & \longrightarrow & 0 \\
 & & & \downarrow & & \downarrow & & & & \\
 & & & 0 & & 0 & & & &
 \end{array}$$

where the extension ξ' is split. Let $\sigma: \mathcal{I}_S \longrightarrow M'$ be such that $q \circ \sigma = id$. Set $m' = \sigma(f)$ and

$n' = \sigma(g)$. Since φ is surjective, there exist elements m, n in M such that $m' = \varphi(m)$ and $n' = \varphi(n)$. Since $\varphi(gm - fn) = gm' - fn' = 0$, there exists an element $h = af + bg$ in \mathcal{F}_G such that $\xi(h) = gm - fn$.

We define $\tau: \mathcal{F}_S \rightarrow M$ by $\tau(f) = m - \xi(b)$ and $\tau(g) = n + \xi(a)$. It is well defined since $g(m - \xi(b)) = f(n + \xi(a))$. It is also clear that $p \circ \tau = id$ because $p(m - \xi(b)) = q \circ \varphi(m - \xi(b)) = q(m') = f$ and analogously $p(n + \xi(a)) = g$. Therefore, the extension ξ' is also split. This proves that the map β is injective, hence an isomorphism.

This completes the proof of the isomorphism $N \cong \text{Ext}^1(\mathcal{F}_S, \mathcal{F}_S)$ and the first part of our statement.

The assertion a) in the statement is now a consequence of the following diagram of exact sequences

$$\begin{array}{ccccc}
 & & & & \text{Ext}^3(\mathcal{O}_S, \mathcal{O}_S) = H^3(\mathcal{O}_S) = 0 \\
 & & & & \downarrow \\
 \text{Ext}^3(\mathcal{O}_G, \mathcal{F}_S) & \longrightarrow & \text{Ext}^3(\mathcal{F}_S, \mathcal{F}_S) & \longrightarrow & \text{Ext}^4(\mathcal{O}_S, \mathcal{F}_S) \\
 \parallel & & & & \downarrow \\
 H^2(\mathcal{O}_S) & & & & \text{Ext}^4(\mathcal{O}_S, \mathcal{O}_G) = H^0(\mathcal{O}_S(-4))^V = 0 \\
 \parallel & & & & \\
 0 & & & &
 \end{array}$$

and assertion b) comes in turn from the diagram

$$\begin{array}{ccccc}
 & & & & \text{Ext}^2(\mathcal{O}_S, \mathcal{O}_S) = H^2(\mathcal{O}_S) = 0 \\
 & & & & \downarrow \\
 \text{Ext}^2(\mathcal{O}_G, \mathcal{F}_S) & \longrightarrow & \text{Ext}^2(\mathcal{F}_S, \mathcal{F}_S) & \longrightarrow & \text{Ext}^3(\mathcal{O}_S, \mathcal{F}_S) \\
 \parallel & & & & \downarrow \\
 H^1(\mathcal{O}_S) & & & & \text{Ext}^3(\mathcal{O}_S, \mathcal{O}_G) = H^1(\mathcal{O}_S(-4))^V = 0 \\
 \parallel & & & & \\
 0 & & & &
 \end{array}$$

■

§2.3. Correspondence between vector bundles and congruences.

We state here some results that come from an idea of Serre, used first by Hartshorne and that can be found with whole generality in the thesis of Vogelaar.

A natural way to construct smooth congruences is the following. Assume we have a vector bundle F of rank r on G that is generated by its global sections. Then ([49] Theor. 2.2) the dependency locus S of $r-1$ general sections of F has codimension two and its singular locus has codimension six in G , so that S is a smooth congruence. We have the following exact sequence

$$0 \longrightarrow \mathcal{O}_G^{r-1} \longrightarrow F \longrightarrow \mathcal{J}_S(c_1(F)) \longrightarrow 0$$

Dualizing this exact sequence we get an epimorphism

$$\mathcal{O}_G^{r-1} \longrightarrow \text{Ext}^1(\mathcal{J}_S(c_1(F)), \mathcal{O}_G) = \text{Ext}^2(\mathcal{O}_S, \omega_G(4-c_1(F))) = \omega_S(4-c_1(F))$$

showing that $\omega_S(4-c_1(F))$ is generated by $r-1$ global sections.

This process has an inverse in the following way. Let S be a locally complete intersection surface in G and a an integer such that $\omega_S(a)$ is generated by s global sections. Thus, we have

$$\begin{aligned} \text{Hom}(\mathcal{O}_G^S, \omega_S(a)) &= H^0(\omega_S(a))^S = H^0(\text{Ext}^2(\mathcal{O}_S, \omega_G(a)))^S = \\ &= \text{Ext}^2(\mathcal{O}_S, \mathcal{O}_G(a-4))^S = \text{Ext}^1(\mathcal{J}_S(4-a), \mathcal{O}_G^S) \end{aligned}$$

so that the morphism $\mathcal{O}_G^S \longrightarrow \omega_S(a)$ showing that $\omega_S(a)$ is generated by s sections provides an extension

$$0 \longrightarrow \mathcal{O}_G^S \longrightarrow F \longrightarrow \mathcal{J}_S(4-a) \longrightarrow 0$$

Using again a result of Vogelaar ([49] Theor. 2.2) we conclude that F is locally free (and in general it fails to be locally free exactly where the s sections do not generate $\omega_S(a)$).

Remark. If we dualize the above exact sequence we obtain

$$0 \longrightarrow \mathcal{O}_G(a-4) \longrightarrow F^V \longrightarrow \mathcal{O}_G^S \longrightarrow \omega_S(a) \longrightarrow 0$$

and taking global sections we obtain that, if the s sections are chosen to be independent, $H^0(F^V) = H^0(\mathcal{O}_G(a-4))$, if $a \leq 3$. In particular, $h^4(F(-4))=0$. If, in addition, we take a basis for $\omega_S(a)$, the vector bundle F that we obtain has $h^3(F(-4))=0$.

APPENDIX TO §2

§2.4. Stability of the restriction of the universal bundles.

Definition. Let S be a surface and H an ample line bundle on it. A vector bundle F on S is said to be H -semistable if for each sub-bundle F' of F one has

$$\frac{c_1(F') \cdot H}{\text{rank}(F')} \leq \frac{c_1(F) \cdot H}{\text{rank}(F)}$$

If the inequality is always strict, F is said to be H -stable.

Conjecture (Dolgachev-Reider [9]). *If S is a smooth congruence that is not contained in a linear complex, then the restriction to S of the universal bundles of G is H -semistable (where H again signifies the hyperplane section).*

This is equivalent to the following: *For any line bundle L on S contained in $E_1^V \otimes \mathcal{O}_S$ or $E_2^V \otimes \mathcal{O}_S$ one has $2HL \leq d$, where d is, as usual, the degree of the congruence.*

One should impose the condition of not being in a linear complex, since the conjecture is false for congruences of odd degree that are contained in a linear complex (see Prop. 3.9).

If this conjecture is true, then, applying Bogomolov's theorem (stating that $c_1^2 \leq 4c_2$ for semistable vector bundles) to both $E_1^V \otimes \mathcal{O}_S$ and $E_2^V \otimes \mathcal{O}_S$ we would obtain that $d_2 \leq 3d_1$ and $d_1 \leq 3d_2$ for all smooth congruences.

We can prove the following

Proposition 2.4. *Let S be a smooth congruence of bidegree (d_1, d_2) . Then*

- a) *If $d_1 \geq d_2$ then $E_1 \otimes \mathcal{O}_S$ is H -semistable.*
- b) *If $d_2 \geq d_1$ then $E_2 \otimes \mathcal{O}_S$ is H -semistable.*

In particular, the conjecture is true for congruences having $d_1 = d_2$.

Proof. Clearly both statements are dual to each other, so that we only need to prove one of them.

Let L be a sub-line bundle of $E_2^V \otimes \mathcal{O}_S$ such that HL is maximum. Thus, the section of $E_2^V \otimes L^{-1}$ vanishes only in a zero-dimensional scheme Z and, therefore, there is an exact

sequence

$$0 \longrightarrow L \longrightarrow E_2^V \otimes \mathcal{O}_S \longrightarrow L^{-1} \otimes \mathcal{I}_{Z,S}(1) \longrightarrow 0$$

The surjection $H^0(E_2^V) \otimes \mathcal{O}_G \longrightarrow E_2^V \longrightarrow E_2^V \otimes \mathcal{O}_S \longrightarrow L^{-1} \otimes \mathcal{I}_{Z,S}(1)$ defines a morphism from the blowing-up of S along Z to \mathbb{P}^3 whose degree (that must be a non-negative number) is $(H-L)^2 - \text{deg}(Z)$.

Since Z is the zero locus of a section of $E_2^V \otimes L^{-1}$ one has that $\text{deg}(Z) = c_2(E_2^V \otimes L^{-1}) = c_2(E_2^V) - c_1(E_2^V) \cdot L + L^2 = d_2 - HL + L^2$. Thus, we obtain that the degree of that morphism is $d_1 - HL$. Therefore, $2HL \leq 2d_1 \leq d$ if we assume $d_1 \leq d_2$. This completes the proof of b). ■

(This result, as well as some other contributions to the conjecture can be found in the thesis of Gross [16]).

We can, therefore re-state the conjecture as follows: *Let S be a smooth congruence. Then, the restriction to S of the universal bundles is H -semistable if and only if there is no line of the congruence that meets all the other lines of the congruence. (As noticed in the proof of Prop. 3.8, this second condition characterizes smooth congruences of odd degree lying in a linear complex).*

Proposition 2.5. *Let S be a smooth congruence and C a general intersection of S with a special linear complex (we recall from lemma 2.2 that C is smooth). Then there are exact sequences*

$$\begin{aligned} 0 &\longrightarrow \mathcal{O}_C(D_1) \longrightarrow E_1^V \otimes \mathcal{O}_C \longrightarrow \mathcal{O}_C(D_2) \longrightarrow 0 \\ 0 &\longrightarrow \mathcal{O}_C(D_2) \longrightarrow E_2^V \otimes \mathcal{O}_C \longrightarrow \mathcal{O}_C(D_1) \longrightarrow 0 \end{aligned}$$

where D_1 and D_2 are divisors on C of degrees d_1 and d_2 (corresponding, respectively to the intersection of S with an α -plane and a β -plane). In particular

- a) If $d_1 > d_2$ then $E_1^V \otimes \mathcal{O}_C$ is not semistable.
- b) If $d_2 > d_1$ then $E_2^V \otimes \mathcal{O}_C$ is not semistable.
- c) If $d_1 = d_2$ then $E_1^V \otimes \mathcal{O}_C$ and $E_2^V \otimes \mathcal{O}_C$ are semistable, but not stable.
- d) If $d_1 = d_2 - 1$ or $d_2 = 2$, then $E_1^V \otimes \mathcal{O}_C$ is stable (and hence also $E_1^V \otimes \mathcal{O}_S$) if and only if the first sequence is not split.
- e) If $d_2 = d_1 - 1$ or $d_1 = 2$, then $E_2^V \otimes \mathcal{O}_C$ is stable (and hence also $E_2^V \otimes \mathcal{O}_S$) if and only if the second sequence is not split.

Proof. We consider a general α -plane in the linear complex. The section of E_1^V defining this α -plane only vanishes on d_1 points of S , and thus it vanishes exactly on a

divisor D_1 of degree d_1 of C . This yields an exact sequence

$$0 \longrightarrow \mathcal{O}_C(D_1) \longrightarrow E_1^\vee \otimes \mathcal{O}_C \longrightarrow \mathcal{O}_C(H-D_1) \longrightarrow 0$$

where H represents the hyperplane section. Clearly, if D_2 is the intersection of C with a β -plane contained in the given linear complex, then $D_1 + D_2 = H$. This proves the existence of the first exact sequence in the statement, the second being dual. ■

§3. LIAISON OF CONGRUENCES

§3.1. Spinor liaison of congruences.

We treat in this section §3 the analogous in G to the theory of linkage of codimension two subvarieties in projective spaces (cf. [36], [39], [40]). The main difference in Grassmannians is that line bundles are not the only indecomposable vector bundles without intermediate cohomology (cf. Prop. 1.3). But this Prop. 1.3 has also the following immediate corollary

Lemma 3.1. *Let F be an indecomposable vector bundle on G not having intermediate cohomology and such that $h^1(F \otimes E_2(l)) = 0$ for all integers l . Then F is either a line bundle or the twist of E_2 with a line bundle.*

This result suggests that the role played by line bundles in the liaison theory in projective spaces should be played in G by both line bundles and twists of E_2 . (Of course, one could use E_1 instead of E_2 along this section). For example, in addition to complete intersections, we have the following

Definition. A *spinor congruence* S_n is a surface in G that is the zero locus of a section of a twist $E_2(n)$ of the universal quotient bundle (that is a spinor bundle of the quadric. This is the reason for our notation). Thus, there is a Koszul exact sequence

$$0 \longrightarrow \mathcal{O}_G \longrightarrow E_2(n) \longrightarrow \mathcal{I}_{S_n}(2n-1) \longrightarrow 0$$

and S_n has bidegree (n^2-n, n^2-n+1) . We recall that $E_2(n)$ has sections if and only if $n \geq 1$ and that in this case $E_2(n)$ is generated by its global sections since $E_2(1)$ is. Therefore, the generic S_n is smooth. We also recall from §2.3 that $\omega_{S_n}(5-2n)$ is generated by one global section, so that we conclude that $\omega_{S_n} = \mathcal{O}_{S_n}(2n-5)$.

We will say that two congruences S and S' are *geometrically linked in G* if their union is either a complete intersection or a spinor congruence (we will also say that S is linked to S' by the complete intersection or by the spinor congruence). Two congruences S and S' are said to be *spinortally linked* if there exist a chain of congruences starting with S and finishing with S' such that any two consecutive congruences in the chain are geometrically linked in G .

Since the difference with the classical liaison theory is in the part involving E_2 , throughout the proofs in this section we will just restrict ourselves to this new part, the other being identical to the classical proofs.

Lemma 3.2. *Let S be a congruence such that there is an exact sequence $0 \longrightarrow F_1 \longrightarrow F_2 \longrightarrow \mathcal{J}_S \longrightarrow 0$ where F_1 and F_2 are vector bundles. Suppose S is linked to S' by a spinor congruence S_n induced from a section of $F_2 \otimes E_2(n)$. Then, there is an exact sequence*

$$0 \longrightarrow F_2^\vee(1-2n) \longrightarrow F_1^\vee(1-2n) \otimes E_2(1-n) \longrightarrow \mathcal{J}_{S'} \longrightarrow 0$$

where the morphisms are the following

$$\circ F_2^\vee(1-2n) \longrightarrow F_1^\vee(1-2n) \text{ is the dual, after a twist of the given } F_1 \longrightarrow F_2.$$

$$\circ F_2^\vee(1-2n) \longrightarrow E_2(1-n) \text{ is the morphism corresponding to the section of } F_2 \otimes E_2(n).$$

$$\circ F_1^\vee(1-2n) \longrightarrow \mathcal{J}_{S'}, \text{ is the composition of } E_2(1-n) \longrightarrow \mathcal{J}_{S_n} \longrightarrow \mathcal{O}_G \text{ with the dual of } E_2(n) \longrightarrow F_1(2n-1), \text{ obtained from the morphism } E_2(n) \longrightarrow F_2(2n-1) \text{ (that is zero after composing with } F_2(2n-1) \longrightarrow \mathcal{J}_S(2n-1) \text{)}.$$

$$\circ E_2(1-n) \longrightarrow \mathcal{J}_{S'}, \text{ is induced by the dual of the section of } E_2(n).$$

Proof. We have the following commutative diagram

$$\begin{array}{ccccccccc} 0 & \longrightarrow & F_1 & \longrightarrow & F_2 & \longrightarrow & \mathcal{O}_G & \longrightarrow & \mathcal{O}_S & \longrightarrow & 0 \\ & & \uparrow & & \uparrow & & \parallel & & \uparrow & & \\ 0 & \longrightarrow & \mathcal{O}_G(1-2n) & \longrightarrow & E_2(1-n) & \longrightarrow & \mathcal{O}_G & \longrightarrow & \mathcal{O}_{S_n} & \longrightarrow & 0 \end{array}$$

whose dualization tensored with $\mathcal{O}_G(1-2n)$ is

$$\begin{array}{ccccccccc}
0 & \longrightarrow & \mathcal{O}_G(1-2n) & \longrightarrow & F_2^V(1-2n) & \longrightarrow & F_1^V(1-2n) & \longrightarrow & \mathcal{I}_{S', S_n} & \longrightarrow & 0 \\
& & \parallel & & \downarrow & & \downarrow & & \downarrow & & \\
0 & \longrightarrow & \mathcal{O}_G(1-2n) & \longrightarrow & E_2(1-n) & \longrightarrow & \mathcal{O}_G & \longrightarrow & \mathcal{O}_{S_n} & \longrightarrow & 0
\end{array}$$

where we have used the identifications $\mathcal{E}xt^1(\mathcal{I}_S, \mathcal{O}_G) = \mathcal{E}xt^2(\mathcal{O}_S, \mathcal{O}_G) = \omega_S(4) = \mathcal{H}am_{\mathcal{O}_{S_n}}(\mathcal{O}_S, \omega_S)(4) = \mathcal{I}_{S', S_n}(2n-1)$.

We conclude by applying the mapping cone construction to this diagram and simplifying. \blacksquare

Remark. A similar proof, or a literal translation of [36] Prop. 2.5 shows that in the same conditions as lemma 3.2, if S is geometrically linked to another congruence S' by a complete intersection of two complexes of degree m and n , then there is an exact sequence

$$0 \longrightarrow F_2^V(-m-n) \longrightarrow F_1^V(-m-n) \otimes \mathcal{O}_G(-m) \otimes \mathcal{O}_G(-n) \longrightarrow \mathcal{I}_{S'} \longrightarrow 0$$

whose morphisms are defined in a similar way.

Lemma 3.3. *Let S be a congruence such that there exists an epimorphism $(\otimes \mathcal{O}_G(-a_i)) \otimes (\otimes E_2(-b_j)) \longrightarrow \mathcal{I}_S$. Let n_0 be the largest integer among the a_i 's and b_j 's and n_1 and m_1 be the first and second largest integers among the a_i 's and b_j 's+1. Let S' and S'' be general congruences geometrically linked to S by a spinor congruence S_n and by the complete intersection of two complexes of degrees m and n . Then*

- If $n \geq n_1 + 1$ and $m \geq m_1 + 1$ then S'' is irreducible.
- If S is smooth and $n \geq n_0$ then S' is smooth.
- If S is smooth and $n \geq n_1$, $m \geq m_1$ then S'' is smooth.

Proof. From the definition of n_1 we obtain an epimorphism $\mathcal{O}_G^N \longrightarrow \mathcal{I}_S(n-1)$ that produces an embedding of \tilde{G} (the blowing up of G along S) in $G \times \mathbb{P}^{N-1}$, that is in turn embedded in a projective space via the Segre embedding. The line bundle producing this projective embedding is clearly $\mathcal{O}_{\tilde{G}}(n)$ (the pull-back to \tilde{G} of $\mathcal{O}_G(n)$), so that its generic section, that corresponds to a complex V of degree n containing S , vanishes on an irreducible divisor.

We again have that $\mathcal{I}_{S, V}(m-1)$ is generated by global sections, and therefore we conclude now that $\mathcal{O}_{\tilde{V}}(m)$ is very ample on the blowing-up \tilde{V} of V along S , and thus, since

its sections correspond to congruences S'' , the general S'' is irreducible. This completes the proof of a).

For b), we observe that we have a surjection $E_2(-n)^N \twoheadrightarrow \mathcal{J}_S$ meaning that S is cut out by all spinor congruences S_n containing it and defining a map $\tilde{G} \rightarrow Gr(1, \mathbb{P}^{N-1})$. In this situation, S' is biregular to the inverse image of the cycle of $Gr(1, \mathbb{P}^{N-1})$ of lines contained in a general \mathbb{P}^{N-2} . Since \tilde{G} is irreducible, S' is. Further, if S is smooth, so is \tilde{G} , and applying [46] Prop. 1.1 (2) we conclude that S' is also smooth.

The statement c) is analogous to the one for varieties in projective spaces (cf. [36]) and its proof is a combination of the proofs of a) and b). From the choice of m and n we have a surjection $\mathcal{O}_G(-n-1) \otimes \mathcal{O}_G(-m-1)^N \twoheadrightarrow \mathcal{J}_S$. If V is the complex of degree $n+1$ containing S induced from this surjection, we obtain another epimorphism $\mathcal{O}_V(-m-1)^N \twoheadrightarrow \mathcal{J}_{S,V}$. This in turn induces a map $\tilde{V} \rightarrow \mathbb{P}^{N-1}$ (where \tilde{V} is the blowing-up of V along S) such that S'' is the inverse image of a general hyperplane. We conclude with the same argument as above. ■

§3.2. Liaison equivalence classes.

We define an equivalence relation among locally Cohen-Macaulay congruences in the following way: Two congruences are equivalent if they are spinorially linked in an even number of steps (i.e., by means of an even number of geometrical linkages). We call the resulting equivalence classes *even spinor liaison classes*.

We also say that two vector bundles F_1 and F_2 on G are *stably equivalent* if $F_1 \otimes (\otimes_i \mathcal{O}_G(a_i)) \otimes (\otimes_j E_2(b_j)) \cong F_2 \otimes (\otimes_k \mathcal{O}_G(c_k)) \otimes (\otimes_l E_2(d_l))$ for some integers a_i, b_j, c_k, d_l, e .

Finally, a vector bundle F on G such that $h^1(F(l)) = h^1(F \otimes E_2(l)) = 0$ for all integers l will be said *not to have H^1* .

With this definitions we can prove a result analogous to the main theorem in [40], giving a completely parallel proof. First, we need some preliminary results.

Lemma 3.4. *Let S be an irreducible congruence such that there exists an exact sequence*

$$0 \longrightarrow F_1 \longrightarrow F_2 \otimes E_2(a) \longrightarrow \mathcal{J}_S \longrightarrow 0$$

where F_1 and F_2 are vector bundles not having H^1 . Then, if the zero locus of the section

of $E_2(1-a)$ defined by dualizing $E_2(a) \longrightarrow \mathcal{J}_S \longrightarrow \mathcal{O}_G$ is not a spinor congruence (i.e., has not pure dimension two), the bundle F_1 decomposes as $F_1 \cong F_3 \oplus E_2(a)$ and we have an exact sequence

$$0 \longrightarrow F_3 \longrightarrow F_2 \longrightarrow \mathcal{J}_S \longrightarrow 0$$

Proof. If the morphism $E_2(a) \longrightarrow \mathcal{J}_S \longrightarrow \mathcal{O}_G$ is identically zero, then the result is clear. We assume therefore that the zero locus of the section of $E_2(1-a)$ consists of a complex V of positive degree, say b , and a spinor congruence S_{1-a-b} .

Since our congruence S is irreducible we conclude that it is contained in one of them, that we assume to be S_{1-a-b} , the other case being analogous. Since $h^1(F_1 \oplus E_2(1-a-b)) = 0$, the section of $E_2 \oplus \mathcal{J}_S(1-a-b)$ comes from a section s of $F_2 \oplus E_2(1-a-b)$. The product of this section s with the section of $\mathcal{O}_G(b)$ defining V has the same image in \mathcal{J}_S as $E_2(a)$. Therefore, after changing bases, we can find a new splitting of $F_2 \oplus E_2(a)$ such that the morphism $E_2(a) \longrightarrow \mathcal{J}_S$ is zero, and then we conclude. ■

Given a locally Cohen-Macaulay congruence S we can construct what we will call a *minimal resolution* of \mathcal{J}_S in the following way. We look consecutively at the ordered set of morphisms from \mathcal{O}_G , E_2 , $\mathcal{O}_G(-1)$, $E_2(-1)$, ... to \mathcal{J}_S and we consider each time those that are not obtained as a composition with the ones considered before. This produces an epimorphism

$$(\oplus_i \mathcal{O}_G(-a_i)) \oplus (\oplus_j E_2(-b_j)) \longrightarrow \mathcal{J}_S$$

whose kernel must be a vector bundle F_0 not having H^1 .

It is clear from this construction that each exact sequence

$$0 \longrightarrow F \longrightarrow (\oplus_k \mathcal{O}_G(c_k)) \oplus (\oplus_l E_2(d_l)) \longrightarrow \mathcal{J}_S \longrightarrow 0$$

where F is a vector bundle not having H^1 , contains as a direct factor the exact sequence corresponding to the minimal resolution.

Lemma 3.5. *Given any locally Cohen-Macaulay congruence S , there is another congruence T in its even liaison class such that the vector bundle appearing as the kernel in the minimal resolution of \mathcal{J}_T has no direct summands of the form $\mathcal{O}_G(1)$ or $E_2(1)$.*

Proof. We start with a resolution of \mathcal{J}_S of the form

$$0 \longrightarrow F \longrightarrow (\otimes_k \mathcal{O}_G(c_k)) \otimes (\otimes_l E_2(d_l)) \longrightarrow \mathcal{I}_S \longrightarrow 0$$

where F has not H^1 . We use lemma 3.3 (a) to link S to an irreducible congruence S' by the complete intersection of two complexes of high enough degrees m and n . We get thus an exact sequence of the form

$$0 \longrightarrow (\otimes_s \mathcal{O}_G(e_s)) \otimes (\otimes_t E_2(f_t)) \longrightarrow F^V(a) \otimes \mathcal{O}_G(-m) \otimes \mathcal{O}_G(-n) \longrightarrow \mathcal{I}_{S'} \longrightarrow 0$$

and applying now lemma 3.4 we can assume that F has no direct factors of the form $E_2(l)$.

We can assume finally that F has no line bundles as direct factors in the same way as in [39] Prop. (1.11). ■

Theorem 3.6. *The even spinor liaison classes of locally Cohen-Macaulay congruences are in 1-1 correspondence with the stable equivalence classes of vector bundles F on G not having H^1 .*

Proof. We define the correspondence by associating to any congruence S the class of the vector bundle appearing for example in the minimal resolution of \mathcal{I}_S . This is well defined, since from Lemma 3.2 congruences in the same even liaison classes define vector bundles F in the same stable equivalence classes.

This correspondence is clearly surjective, since given a vector bundle F , for a sufficiently large integer n , $F^V(n)$ is generated by its global sections, and the construction in §2.3 provides then a (smooth) congruence S and an exact sequence

$$0 \longrightarrow \mathcal{O}_G^S \longrightarrow F^V(n) \longrightarrow \mathcal{I}_S(a) \longrightarrow 0$$

Hence, a general linkage produces a congruence S' whose corresponding stable equivalence class of vector bundles is the one of F .

We are left with the task of proving the correspondence is injective. Consider two congruences defining the same stable class of vector bundles. By lemma 3.5 we can assume these congruences define, up to a twist, the same vector bundle. Linking them once, we obtain two congruences S and S' together with exact sequences

$$0 \longrightarrow (\otimes_l \mathcal{O}_G(-a_l)) \otimes (\otimes_j E_2(-b_j)) \longrightarrow F^V(c) \longrightarrow \mathcal{I}_S \longrightarrow 0$$

$$0 \longrightarrow (\otimes_l \mathcal{O}_G(-a'_l)) \otimes (\otimes_j E_2(-b'_j)) \longrightarrow F^V(d) \longrightarrow \mathcal{I}_{S'} \longrightarrow 0$$

where F is a vector bundle not having H^1 and only two line bundles as direct factors (observe also that the number of line bundles and twists of E_2 in the kernel of both sequences must be the same by computing second Chern classes).

We denote by s_j the maps $E_2(-b_j) \longrightarrow F^\vee(c)$ in the first exact sequence and by s'_j the ones in the second. We assume that we know that $s_1=s'_1$, $s_2=s'_2$, ..., $s_k=s'_k$ and will try to prove that also $s_{k+1}=s'_{k+1}$ for some other two congruences in the same classes as S and S' .

Let l be large enough so that there exists a section s in $H^0(F^\vee \otimes E_2(l))$ whose images in $H^0(E_2 \otimes \mathcal{J}_S(l-c))$ and $H^0(E_2 \otimes \mathcal{J}_{S'}(l-d))$ define spinor congruences containing S and S' , linking them to congruences T and T' . There are exact sequences

$$0 \longrightarrow F(1-2l+c) \longrightarrow E_2(1-l+c) \otimes (\otimes_i \mathcal{O}_G(-a_i+1-2l+2c)) \otimes (E_2(2-b_j-2l+2c)) \longrightarrow \mathcal{J}_T \longrightarrow 0$$

$$0 \longrightarrow F(1-2l+d) \longrightarrow E_2(1-l+d) \otimes (\otimes_i \mathcal{O}_G(-a'_i+1-2l+2d)) \otimes (E_2(2-b'_j-2l+2d)) \longrightarrow \mathcal{J}_{T'} \longrightarrow 0$$

Since $E_2(2-b_{k+1}-2l+2c)$ (resp. $E_2(2-b'_{k+1}-2l+2d)$) is not a direct factor of $F(1-2l+c)$ (resp. $F(1-2l+d)$), then from lemma 3.4 we conclude that it defines a spinor congruence containing T (resp. T') and linking it to W (resp. W') and providing

$$\begin{aligned} 0 \longrightarrow E_2(5+2b_{k+1}+5l-3c) \otimes (\otimes_i \mathcal{O}_G(a_i+4+6l-4c+2b_{k+1})) \otimes ({}_{j \neq k+1} \otimes E_2(2-b_j-2l+2c)) \\ \longrightarrow F^\vee(4+6l-3c+2b_{k+1}) \longrightarrow \mathcal{J}_W \longrightarrow 0 \end{aligned}$$

$$\begin{aligned} 0 \longrightarrow E_2(5+2b'_{k+1}+5l-3d) \otimes (\otimes_i \mathcal{O}_G(a'_i+4+6l-4d+2b'_{k+1})) \otimes ({}_{j \neq k+1} \otimes E_2(2-b'_j-2l+2d)) \\ \longrightarrow F^\vee(4+6l-3d+2b'_{k+1}) \longrightarrow \mathcal{J}_{W'} \longrightarrow 0 \end{aligned}$$

Now W and W' are in the same even liaison class as S and S' respectively, and in the resolutions of \mathcal{J}_W and $\mathcal{J}_{W'}$, there is one more coincident morphism, namely the morphisms

$$\begin{aligned} E_2(5+2b_{k+1}+5l-3c) &\longrightarrow F^\vee(4+6l-3c+2b_{k+1}) \\ E_2(5+2b'_{k+1}+5l-3d) &\longrightarrow F^\vee(4+6l-3d+2b'_{k+1}) \end{aligned}$$

are both defined by the above section s .

Analogously, and in the same way as in [40] one can find in the same liaison class congruences with the same morphisms in the resolutions of their ideal sheaves, and hence the same congruence. This completes the proof. \blacksquare

As a consequence of this theorem we obtain the following

Proposition 3.7. *Let S be a locally Cohen-Macaulay congruence. The following are equivalent*

- (i) $h^i(\mathcal{I}_S(l))=0$ for all integers l and $i=1,2$.
- (ii) S is spinorially linked to a complete intersection.
- (iii) There exists an exact sequence

$$0 \longrightarrow (\mathcal{O}_G(a_i)) \otimes (\mathcal{O}_{E_2}(b_j)) \longrightarrow (\mathcal{O}_G(c_k)) \otimes (\mathcal{O}_{E_2}(d_l)) \longrightarrow \mathcal{I}_S \longrightarrow 0$$

for some integers a_i, b_j, c_k, d_l .

Proof. Clearly (iii) implies (i), and also (ii) implies (iii) from lemma 3.2. Now, assume (i) holds for a locally Cohen-Macaulay congruence S . Let

$$0 \longrightarrow F \longrightarrow (\mathcal{O}_G(c_k)) \otimes (\mathcal{O}_{E_2}(d_l)) \longrightarrow \mathcal{I}_S \longrightarrow 0$$

be a minimal resolution of \mathcal{I}_S . Hence, F is a vector bundle verifying $h^1(F(l))=h^1(F \otimes E_2(l))=0$ for all integers l . Our assumption (i) provides the vanishing of all $h^2(F(l))$ and $h^3(F(l))$. Applying Lemma 3.1, F has the form $(\mathcal{O}_G(a_i)) \otimes (\mathcal{O}_{E_2}(b_j))$, so we get (iii). Furthermore, using Theor. 3.5, S is in the same even liaison class as a complete intersection, just proving (ii). ■

Definition. Because of its similarity with the projective case, a congruence satisfying the conditions in Prop. 3.5 will be called an *arithmetically Cohen-Macaulay congruence*.

§3.3. Smooth congruences lying in a linear complex.

As an easy application of liaison theory we obtain a resolution of the ideal sheaf of any smooth congruence that is contained in a linear complex.

Proposition 3.8. *Let S be a smooth congruence that is contained in a linear complex of G . Then S is arithmetically Cohen-Macaulay in G and \mathcal{I}_S has one of the following resolutions*

a) $0 \longrightarrow \mathcal{O}_G(-n-1) \longrightarrow \mathcal{O}_G(-1) \otimes \mathcal{O}_G(-n) \longrightarrow \mathcal{I}_S \longrightarrow 0$ and S has invariants $(d_1, d_2) = (n, n)$, $K = (n-3)H$, $\chi = \frac{2n^3 - 9n^2 + 13n}{6}$.

b) $0 \longrightarrow E_2(-n) \longrightarrow O_G(-n)^2 \otimes O_G(-1) \longrightarrow \mathcal{F}_S \longrightarrow 0$ and the invariant of S are $(d_1, d_2) = (n, n-1)$, $\pi = (n-1)(n-2)$, $KH = 2n^2 - 8n + 3$, $K^2 = 2n^3 - 15n^2 + 30n - 8$, $\chi = \frac{n^3 - 6n^2 + 11n - 3}{3}$.

c) $0 \longrightarrow O_G(-n)^2 \longrightarrow E_2(-n+1) \otimes O_G(-1) \longrightarrow \mathcal{F}_S \longrightarrow 0$ and the invariant of S are $(d_1, d_2) = (n-1, n)$, $\pi = (n-1)(n-2)$, $KH = 2n^2 - 8n + 3$, $K^2 = 2n^3 - 15n^2 + 30n - 8$, $\chi = \frac{n^3 - 6n^2 + 11n - 3}{3}$.

Proof. Our assumption on S means that it can be considered as a surface in \mathbb{P}^4 that is contained in a hyperquadric X —namely the intersection of G with the hyperplane \mathbb{P}^4 defined by the linear complex. This hyperquadric is either smooth or, in case that \mathbb{P}^4 is tangent to G at a point x , is a cone with vertex x over a smooth quadric of \mathbb{P}^3 .

In case X is smooth or x is not in S , it is well known that S is the complete intersection of X with a hypersurface of \mathbb{P}^4 of degree, say n (see [42] §3 or [3] for a proof). Thus, S is the complete intersection in G of the linear complex and another complex of degree n , which is case a).

If X is a cone whose vertex x is in S , then S is known (see again [42]) to be geometrically linked to a plane by the complete intersection of X with a hypersurface of \mathbb{P}^4 of certain degree n . Therefore S is geometrically linked in G to a plane Y by a complete intersection of the linear complex and a complex of degree n .

If Y is a β -plane, then there is an exact sequence

$$0 \longrightarrow O_G(-1) \longrightarrow E_2 \longrightarrow \mathcal{F}_Y \longrightarrow 0$$

so that after making a linkage of Y by a complete intersection of complexes of degrees 1 and n we obtain the resolution b) for \mathcal{F}_S .

In case Y is an α -plane, we obtain an exact sequence —using $n=1$ in case b)

$$0 \longrightarrow E_2(-n) \longrightarrow O_G(-1)^3 \longrightarrow \mathcal{F}_S \longrightarrow 0$$

and a linkage by a complete intersection of complexes of degrees 1 and n yields the resolution c) for \mathcal{F}_S after canceling a redundant term $O_G(-n)$.

We compute now the invariants of each possible type.

In case a) clearly $(d_1, d_2) = (n, n)$ and $K = (n-3)H$, since S is the complete intersection in \mathbb{P}^4 of a quadric and a hypersurface of degree n . From this we derive $K^2 = 2n(n-3)^2$,

$KH=2n(n-3)$ and, from the adjunction formula, $\pi=(n-1)^2$. Applying now the relation given by Prop. 2.1, we get $\chi = \frac{2n^3 - 9n^2 + 13n}{6}$.

In case b), we first compute the Chern classes of the vector bundles presenting \mathcal{F}_S and obtain

$$\begin{aligned} c_t(E_2(-n)) &= 1 + (-2n-1)t + (n^2 + n, n^2 + n + 1)t^2 \\ c_t(\mathcal{O}_G(-n)^2 \otimes \mathcal{O}_G(-1)) &= 1 + (-2n-1)t + (n^2 + 2n, n^2 + 2n)t^2 - 2n^2 t^3 \end{aligned}$$

so that we get

$$c_t(\mathcal{F}_S) = 1 + (n, n-1)t^2 + (2n^2 - 1)t^3 + (2n^3 + n^2 - 2n)t^4$$

so that, from the relations in §2.1 we obtain the announced invariants for S .

Since case c) is dual of case b), we obtain the same invariants except the order and class, which are permuted. ■

From this result we derive the following information about the restriction of the universal bundles.

Proposition 3.9. *Let S be a smooth congruence of odd degree that is contained in a linear complex. Then one of the following holds*

(i) *The congruence is in case b) above and there is an exact sequence*

$$0 \longrightarrow \mathcal{O}_S((n-3)H-K) \longrightarrow E_2^\vee \otimes \mathcal{O}_S \longrightarrow \mathcal{O}_S(K-(n-4)H) \longrightarrow 0$$

that shows that $E_2^\vee \otimes \mathcal{O}_S$ is not H -semistable.

(ii) *The congruence is in case c) and there exists an exact sequence*

$$0 \longrightarrow \mathcal{O}_S((n-3)H-K) \longrightarrow E_1^\vee \otimes \mathcal{O}_S \longrightarrow \mathcal{O}_S(K-(n-4)H) \longrightarrow 0$$

showing that $E_1^\vee \otimes \mathcal{O}_S$ is not H -semistable.

(We will see in Prop. 5.7 that these sequences are not split with the exception of $n=1$ and $n=2$).

Proof. If we are in case b) then one easily obtains $h^0(E_2^\vee \otimes \mathcal{O}_S(K-(n-3)H)) = h^2(E_2 \otimes \mathcal{O}_S(n-3)H) = h^3(E_2 \otimes \mathcal{F}_S(n-3)) = h^4(E_2 \otimes E_2(-3)) = 1$, so that there exists a non-zero morphism $\mathcal{O}_S((n-3)H-K) \longrightarrow E_2^\vee \otimes \mathcal{O}_S$. We have to prove it is an inclusion of vector bundles.

Let C be a general intersection of S with a special linear complex. From Prop. 2.5 there exists an exact sequence

$$0 \longrightarrow \mathcal{O}_C(D_2) \longrightarrow E_2^V \otimes \mathcal{O}_C \longrightarrow \mathcal{O}_C(D_1) \longrightarrow 0$$

with $\deg(D_2)=n$, which shows that $E_2^V \otimes \mathcal{O}_C$ is not semistable. Hence, $\mathcal{O}_S((n-3)H-K) \otimes \mathcal{O}_C = \mathcal{O}_C(D_2)$ since it also has degree n .

This proves that the restriction of the above morphism to a general C is an inclusion of vector bundles, and hence, the morphism itself only fails to be an inclusion of vector bundles in a group of points. The degree of this group of points is then given by the Porteous formula and is

$$\begin{aligned} c_2(E_2^V \otimes \mathcal{O}_S(K-(n-3)H)) &= \\ c_2(E_2^V \otimes \mathcal{O}_S) + (K-(n-3)H) \cdot c_1(E_2^V \otimes \mathcal{O}_S) + (K-(n-3)H)^2 &= \\ d_2 + (K-(n-3)H)H + K^2 - 2(n-3)KH + (n-3)^2 d &= \\ (n-1) + (2n^2 - 8n + 3) - (n-3)(2n-1) + (2n^3 - 15n^2 + 38n - 8) - & \\ -2(n-3)(2n^2 - 8n + 3) + (n-3)^2(2n-1) &= 0 \end{aligned}$$

This shows the existence of the announced exact sequence (the cokernel is calculated by just computing first Chern classes).

The non H -semistability of $E_2^V \otimes \mathcal{O}_S$ comes from the invariants of S computed in the above Prop. 3.8. Indeed, $((n-3)H-K)H = (n-3)(2n-1) - (2n^2 - 8n + 3) = n > \frac{2n-1}{2}$.

This completes the proof of (i), the one for (ii) being completely analogous just permuting subindices 1 and 2. ■

§4. SMOOTH CONGRUENCES OF LOW DEGREE

§4.1. Smooth congruences of degree at most eight.

The results of this section correspond to those published in [1]. The proofs we offer here are slightly different and simpler since we make use of Prop.1.3. As new information, we add here as much information as we know on the restriction of the universal bundles to our congruences.

The method we use to give a classification is just to look at lists of smooth irreducible surfaces of degree d at most eight in \mathbb{P}^5 (cf. [25],[26],[27]) and check which ones of them verify the numerical relation given by Prop. 2.1 (for all possible d_1 and d_2 such that $d_1+d_2=d$).

We eliminate the Segre embedding S of the product of \mathbb{P}^1 with a smooth plane quartic. Indeed, since the Segre embedding X of $\mathbb{P}^1 \times \mathbb{P}^2$ is not in any smooth quadric of \mathbb{P}^5 , this surface S cannot be in G , since otherwise it should be contained in the complete intersection of X with the quadric G , that is a (3,3) congruence and S must be a (4,4) congruence.

Taking this case away, we find the possibilities that we resume next in a table (we only write congruences with $d_1 \leq d_2$ since subindices 1 and 2 are permuted by duality) where we use the following notations

$\tilde{\mathbb{P}}^2(x_1, x_2, \dots, x_r)$ will denote the blowing-up of \mathbb{P}^2 in the points x_1, x_2, \dots, x_r ; E_1, E_2, \dots, E_r will be the corresponding exceptional divisors and L will represent the pull-back of the line in \mathbb{P}^2 .

-Using the notations of [19] Chapter V.2, X_e will be a ruled surface over a curve C of genus $g=q$, the integer $-e$ being the minimum self-intersection number for a section C_0

of $p: X_e \rightarrow C$. The fiber of the projection to C will be denoted with F . The expression $aC_0 + \mathcal{L}F$ will represent the line bundle $O_{X_e}(aC_0) \otimes p^* \mathcal{L}$ where \mathcal{L} is a line bundle on C . When C is \mathbb{P}^1 we just write an integer n to represent the line bundle $\mathcal{L} = \mathcal{O}_{\mathbb{P}^1}(n)$.

-Complete intersection (a,b,c) means the complete intersection in \mathbb{P}^5 of three hypersurfaces of degrees a, b and c .

	(d_1, d_2)	π	q	p_g	Description	Embedding
1)	(0,1)	0	0	0	\mathbb{P}^2	$ L $
2)	(1,1)	0	0	0	$X_0 = \mathbb{P}^1 \times \mathbb{P}^1$	$ C_0 + F $
3)	(1,2)	0	0	0	$\tilde{\mathbb{P}}^2(x)$	$ 2L - E $
4)	(1,3)	0	0	0	\mathbb{P}^2	$ 2L $
5)	(2,2)	0	0	0	rational normal scroll in \mathbb{P}^5	
6)	(2,2)	1	0	0	$\tilde{\mathbb{P}}^2(x_1, x_2, \dots, x_5)$	$3L - E_1 - E_2 - \dots - E_5$
7)	(2,3)	1	0	0	$\tilde{\mathbb{P}}^2(x_1, x_2, x_3, x_4)$	$3L - E_1 - E_2 - E_3 - E_4$
8)	(2,3)	2	0	0	$\tilde{\mathbb{P}}^2(x_1, x_2, \dots, x_8)$	$4L - 2E_1 - E_2 - E_3 - \dots - E_8$
9)	(3,3)	1	1	0	X_0	$ C_0 + \mathcal{L}F $ ($\text{deg} \mathcal{L} = 3$)
10)	(3,3)	1	0	0	$\tilde{\mathbb{P}}^2(x_1, x_2, x_3)$	$3L - E_1 - E_2 - E_3$
11)	(3,3)	2	0	0	$\tilde{\mathbb{P}}^2(x_1, x_2, \dots, x_7)$	$4L - 2E_1 - E_2 - E_3 - \dots - E_7$
12)	(3,3)	4	0	1	K3 surface, complete intersection (1,2,3) in \mathbb{P}^5	
13)	(3,4)	3	0	0	$\tilde{\mathbb{P}}^2(x_1, x_2, \dots, x_9)$	$4L - E_1 - E_2 - \dots - E_9$
14)	(3,4)	6	0	2	$ K : S \rightarrow \mathbb{P}^1$ minimal elliptic fibration	
15)	(2,6)	3	1	0	X_{-1}	$ 2C_0 + \mathcal{L}F $ ($\text{deg} \mathcal{L} = 1$)
16)	(3,5)	4	0	0	$\tilde{\mathbb{P}}^2(x_1, x_2, \dots, x_{10})$	$6L - 2E_1 - \dots - 2E_6 - E_7 - \dots - E_{10}$
17)	(4,4)	3	0	0	$\tilde{\mathbb{P}}^2(x_1, x_2, \dots, x_7)$	$6L - 2E_1 - 2E_2 - \dots - 2E_7$
18)	(4,4)	4	0	0	$\tilde{\mathbb{P}}^2(x_1, x_2, \dots, x_{11})$	$5L - 2E_1 - 2E_2 - E_3 - E_4 - \dots - E_{11}$
19)	(4,4)	5	0	1	K3 surface, complete intersection (2,2,2) in \mathbb{P}^5	
20)	(4,4)	9	0	5	General type, complete intersection (1,2,4) in \mathbb{P}^5	

Now we study in detail each one of these congruences, showing their existence, in all cases except type 9), by describing them as the dependency locus of $r-1$ sections of a bundle of rank r that is generated by global sections, finding a resolution of their ideal sheaf \mathcal{I}_S and giving information about their Hilbert scheme (dimension, unirationality, and in some cases rationality).

For example, if congruences of a family are described as dependency locus of $r-1$ sections of a fixed rank r vector bundle F that is generated by its global sections, then the Hilbert scheme is given by an open subscheme of the quotient of

$Gr(r-2, \mathbb{P}(H^0(F)^\vee))$ by $\mathbb{P}(End(F)^\vee)$ and hence it is rational if F has no automorphisms.

We will just enumerate the results whose proofs either can be found in [1] or are derived immediately from Prop. 1.3 or lemma 2.3 (which make the work in [1] much easier).

Congruences of type 1).

These are clearly the β -planes X_2 , so that they form a smooth family of dimension 3 whose Hilbert scheme is naturally identified with \mathbb{P}^{3V} .

Tensoring with E_1 the Koszul sequence of the section of E_2^\vee that gives X_2 we obtain

$$\begin{array}{ccccccc}
 0 & \longrightarrow & E_1 & \longrightarrow & E_1 \otimes E_2(1) & \longrightarrow & E_1(1) \longrightarrow E_1 \otimes \mathcal{O}_{X_2}(1) \longrightarrow 0 \\
 & & & & \searrow & & \nearrow \\
 & & & & E_1 \otimes \mathcal{I}_{X_2}(1) & & \\
 & & \nearrow & & \searrow & & \\
 & & 0 & & & & 0
 \end{array}$$

so that $h^1(E_1 \otimes \mathcal{O}_{X_2}(l)) = h^2(E_1 \otimes \mathcal{I}_{X_2}(l)) = h^2(E_1 \otimes E_2(l)) = 0$ for all integers l . Hence, $E_1^\vee \otimes \mathcal{O}_{X_2}$ has no intermediate cohomology, and applying Horrocks' theorem for vector bundles in \mathbb{P}^2 it is a direct sum of two line bundles. Since $h^0(E_1 \otimes \mathcal{O}_{X_2}) = h^1(E_1 \otimes \mathcal{I}_{X_2}) = h^1(E_1 \otimes E_2) = 1$ then it should be $E_1^\vee \otimes \mathcal{O}_{X_2} = \mathcal{O}_{\mathbb{P}^2} \oplus \mathcal{O}_{\mathbb{P}^2}(1)$.

Therefore, $E_2 \otimes \mathcal{O}_{X_2}$ is the kernel of the Euler sequence of \mathbb{P}^2 , i.e., $E_2 \otimes \mathcal{O}_{X_2} = \Omega_{\mathbb{P}^2}(1)$.

Congruences of type 2).

They are quadrics in a \mathbb{P}^3 inside \mathbb{P}^5 , i.e., complete intersections of two linear complexes of G . Since special linear complexes form a hyperquadric inside the \mathbb{P}^{5V} parametrizing all linear complexes, we can consider our congruence S as the intersection of two special complexes (those appearing as intersection of the hyperquadric and our pencil of linear complexes). Hence, the congruence consists of those lines meeting two given lines of \mathbb{P}^3 (namely the two lines defining the special linear complexes).

This geometrical description clearly corresponds to the embedding of $S = \mathbb{P}^1 \times \mathbb{P}^1$ in G by the rank two bundle $\mathcal{O}_S(1,0) \otimes \mathcal{O}_S(0,1)$. Indeed, the line bundle $\mathcal{O}_S(1,0)$ maps S to a line L_1 in \mathbb{P}^3 and $\mathcal{O}_S(0,1)$ to another disjoint line L_2 . Then, S is naturally identified with

$L_1 \times L_2$ and the congruence consists of the lines joining a point of L_1 with a point of L_2 .

Therefore, the restriction to S of E_2^V is $\mathcal{O}_S(1,0) \otimes \mathcal{O}_S(0,1)$ and, since the construction is self-dual, the same holds for E_1^V .

Since S is a complete intersection of two linear complexes we have an exact sequence

$$0 \longrightarrow \mathcal{O}_G(-2) \longrightarrow \mathcal{O}_G(-1)^2 \longrightarrow \mathcal{I}_S \longrightarrow 0$$

and the Hilbert scheme is the open subset of $Hilb^2 G$ consisting of two skew lines. This is smooth, rational and has dimension 8.

Congruences of type 3).

We know from Propositions 3.8 and 3.9 that there are exact sequences

$$\begin{array}{ccccccc} 0 & \longrightarrow & \mathcal{O}^2 & \longrightarrow & E_2(1) \otimes \mathcal{O}_G(1) & \longrightarrow & \mathcal{I}_S(2) \longrightarrow 0 \\ 0 & \longrightarrow & \mathcal{O}_S(L) & \longrightarrow & E_1^V \otimes \mathcal{O}_S & \longrightarrow & \mathcal{O}_S(L-E) \longrightarrow 0 \end{array}$$

The second one shows that $E_1^V \otimes \mathcal{O}_S$ is an element of

$$Ext^1(\mathcal{O}_S(L-E), \mathcal{O}_S(L)) = H^1(\mathcal{O}_S(E)) = 0$$

so that $E_1^V \otimes \mathcal{O}_S = \mathcal{O}_S(L) \otimes \mathcal{O}_S(L-E)$ proving that its dual (2,1) can be interpreted geometrically as follows: The line bundle $\mathcal{O}_S(L-E)$ maps S onto a line M of \mathbb{P}^3 and $\mathcal{O}_S(L)$ defines the blowing-up of \mathbb{P}^2 at x and hence maps S onto a plane Π and contracts the exceptional divisor E in a point p of Π . Our congruence S consists of a given isomorphism σ between the line M and the pencil of lines in Π passing through p , and lines of the congruence are those in the pencils formed by a point q of M and the plane determined by this point and the line $\sigma(q)$ in Π .

Therefore, the congruence has the following geometrical interpretation: We fix an isomorphism σ between a line M of \mathbb{P}^3 and the pencil of lines defined by a point p in a plane Π ; the lines of the congruence are those L that are in a pencil defined by a plane Λ containing M and the point $\Lambda \cap \sigma(\Lambda)$.

In the plane Π , the union, as N varies in the pencil of lines passing through $\Pi \cap M$, of the intersections of N with $\sigma(N)$ describes a conic Q (meeting the line M in one point), and from the above description we conclude that the congruence consists of those

lines joining a point of Q and a point of M (or more precisely, it is the closure of this, when the two points are taken to be different each other).

Since it is a rational congruence, it describes a smooth Hilbert scheme of dimension 11 (Lemma 2.3), which is irreducible and rational because it is parametrized by the generic choice of a line M and a conic Q meeting in one point.

Congruences of type 4).

There is an exact sequence

$$0 \longrightarrow \mathcal{O}_G^3 \longrightarrow E_2(1) \otimes E_2(1) \longrightarrow \mathcal{I}_S(2) \longrightarrow 0$$

From this we get that for all integers l we have $h^1(E_1^\vee \otimes \mathcal{O}_S(l)) = h^2(E_1^\vee \otimes \mathcal{I}_S(l)) = h^2(E_1^\vee \otimes \mathcal{F}(l-2)) = 0$. This proves that $E_1^\vee \otimes \mathcal{O}_S$ is a vector bundle on \mathbb{P}^2 that has no first cohomology when tensoring with line bundles of even degree. By duality, we obtain that first cohomology groups also vanish when tensoring with line bundles of odd degree. Applying Horrocks' theorem it should split into a direct sum of two line bundles, which can be easily checked to be $E_1^\vee \otimes \mathcal{O}_S = \mathcal{O}_{\mathbb{P}^2}(1) \otimes \mathcal{O}_{\mathbb{P}^2}(1)$.

Hence, we derive the following description for the dual congruence (3,1): It consists of lines joining two homologous points of two fixed planes Π_1 and Π_2 in \mathbb{P}^3 under a given isomorphism between them.

We see from this that through a general point p of \mathbb{P}^3 there pass three lines of this (3,1) spanning the whole space (these three lines correspond to the three points of Π_1 that have the same image in Π_2 under the given isomorphism and the one defined by projecting from p). These three lines determine three planes that contain two lines of the congruence (3,1), and therefore an infinity of them (since the class is one). Therefore, the singular planes of the congruence describe a twisted cubic in \mathbb{P}^{3V} and each line of the congruence lies in two singular planes.

Coming back to our original congruence (1,3), we conclude that it consists of the bisecants to a twisted cubic. The Hilbert scheme of these congruences is isomorphic to the Hilbert scheme of twisted cubics, hence smooth, rational, irreducible and of dimension 12.

Congruences of type 5).

There is an exact sequence

$$0 \longrightarrow \mathcal{O}_G^3 \longrightarrow E_1(1) \otimes E_2(1) \longrightarrow \mathcal{I}_S(2) \longrightarrow 0$$

We have that $h^0(E_2^V \otimes \mathcal{O}_S(-1,0)) = h^2(E_2 \otimes \mathcal{O}_S(-1,-2)) = h^3(E_2 \otimes \mathcal{I}_S(-1)) = h^3(E_2 \otimes E_1(-2)) + h^3(E_2 \otimes E_2(-2)) = 1$. Hence we obtain a non-zero morphism $\varphi: \mathcal{O}_S(1,0) \longrightarrow E_2^V \otimes \mathcal{O}_S$. Restricting to a general special linear complex we obtain a smooth curve C (from lemma 2.2) and φ restricts to $\mathcal{L} \longrightarrow E_2^V \otimes \mathcal{O}_C$ where \mathcal{L} is a line bundle on C of degree two. Since $E_2^V \otimes \mathcal{O}_C$ is semistable (Prop. 2.5) then φ restricted to C is an inclusion of bundles.

Hence, φ fails to be an inclusion of bundles just on a subscheme of finite length of S . This length is given by $c_2(E_2^V \otimes \mathcal{O}_S(-1,0)) = c_2(E_2^V \otimes \mathcal{O}_S) + c_1(E_2^V \otimes \mathcal{O}_S) \cdot c_1 \mathcal{O}_S(-1,0) + (c_1 \mathcal{O}_S(-1,0))^2 = 2 - c_1 \mathcal{O}_S(2,2) \cdot c_1 \mathcal{O}_S(-1,0) + 0 = 0$. Thus, we obtain a presentation for $E_2^V \otimes \mathcal{O}_S$ as an extension of two line bundles

$$0 \longrightarrow \mathcal{O}_{\mathbb{P}^1 \times \mathbb{P}^1}(1,0) \longrightarrow E_2^V \otimes \mathcal{O}_S \longrightarrow \mathcal{O}_{\mathbb{P}^1 \times \mathbb{P}^1}(0,2) \longrightarrow 0$$

the same being true for $E_1^V \otimes \mathcal{O}_S$ by duality. This extension is not split as we will see in Prop. 5.7.

The geometric description for this congruence is proved in [22] to be given by an automorphism of a plane conic Q and a point p outside the span of Q , the congruence consisting of the lines in the pencils determined by a point q of the conic and the plane spanned by p, q and the image of q under the given automorphism. One also checks that the Hilbert scheme of these congruences is smooth, irreducible and rational and has dimension 14.

Congruences of type 6).

This is a complete intersection of two complexes of degrees one and two, so there is an exact sequence

$$0 \longrightarrow \mathcal{O}_G \longrightarrow \mathcal{O}_G(1) \otimes \mathcal{O}_G(2) \longrightarrow \mathcal{I}_S(3) \longrightarrow 0$$

Its geometric description is given in [28] page 303 as the lines that meet corresponding lines (by given isomorphisms) of three pencils having three corresponding lines concurrent and coplanar.

The Hilbert scheme is smooth of dimension 18 after Lemma 2.3. If I is the incidence variety in $G \times \mathbb{P}^{5V}$, then this Hilbert scheme is an open subset of $p_{2*} p_1^* \mathcal{O}_G(2)$, so that it is rational and irreducible.

Congruences of type 7).

We have an exact sequence

$$0 \longrightarrow \mathcal{O}_G \longrightarrow E_2(2) \longrightarrow \mathcal{I}_S(3) \longrightarrow 0$$

The geometric description, given in [28] page 289 and also obtained in [22] from the fact that S is a Del Pezzo surface, is as follows: it consists of lines which meet corresponding lines of three pencils having three corresponding lines concurrent.

The Hilbert scheme is smooth of dimension 19 and it is rational, since it is canonically isomorphic to an open subscheme of $\mathbb{P}(H^0(E_2(2))^V)$.

Congruences of type 8).

Since it is contained in a linear complex, we obtain from Propositions 3.8 and 3.9 exact sequences

$$\begin{aligned} 0 \longrightarrow \mathcal{O}_S(3L - E_1 - E_2 - \dots - E_8) \longrightarrow E_1^V \otimes \mathcal{O}_S \longrightarrow \mathcal{O}_S(L - E_1) \longrightarrow 0 \\ 0 \longrightarrow \mathcal{O}_G^2 \longrightarrow E_2(1) \otimes \mathcal{O}_G(2) \longrightarrow \mathcal{I}_S(3) \longrightarrow 0 \end{aligned}$$

The first one is not split, since $\mathcal{O}_S(3L - E_1 - E_2 - \dots - E_8)$ has one base point, while $E_1^V \otimes \mathcal{O}_S$ is generated by its global sections.

The second exact sequence tells us that the Hilbert scheme is parametrized by an open subset of $Gr(1, \mathbb{P}(H^0(E_2(1) \otimes \mathcal{O}_G(2))^V))$, so it is unirational and irreducible, and we know from Lemma 2.3 that it is smooth of dimension 23.

Congruences of type 9).

It is always linked to the disjoint union of an α -plane and a β -plane and hence we have for \mathcal{I}_S a resolution

$$0 \longrightarrow \dot{E}(-3) \longrightarrow \mathcal{O}_G(-3) \oplus \mathcal{O}_G(-2) \oplus \mathcal{O}_G(-2) \longrightarrow \mathcal{I}_S \longrightarrow 0$$

(We observe that we have an epimorphism $\mathcal{O}_G(-2)^{14} \longrightarrow \dot{E} \longrightarrow \mathcal{I}_X$ and hence the generic linkage of the disjoint union \dot{X} of an α -plane and a β -plane produces a smooth (3,3) congruence, after Lemma 3.3. This proves the existence of such smooth congruences).

The Hilbert scheme of these congruences is smooth of dimension 18, and it is also unirational because of the above construction.

Finally, a few words about a possible presentation of these congruences as the dependency locus of $r-1$ sections of a vector bundle of rank r . It is certainly possible, since $\omega_S(2)$ is generated by two global sections -because $(K+2H)^2=0$ -to find a rank three vector bundle F appearing in an exact sequence

$$0 \longrightarrow \mathcal{O}_G^2 \longrightarrow F \longrightarrow \mathcal{I}_S(2) \longrightarrow 0$$

but it is not useful to our purposes since it is not generated by its global sections and we cannot conclude from this the irreducibility of the Hilbert scheme.

Congruences of type 10).

There is an exact sequence

$$0 \longrightarrow \mathcal{O}_G \longrightarrow \dot{E}(2) \longrightarrow \mathcal{I}_S(3) \longrightarrow 0$$

The Hilbert scheme of these congruences is rational and irreducible since it is defined by an open subscheme of $\mathbb{P}(\pi_* \dot{E} \otimes \mathcal{O}_G(2))^\vee$ (using the notations of §2.3). From lemma 2.3 we also obtain this Hilbert scheme is smooth and has dimension 20.

Congruences of type 11).

There is a presentation for the ideal sheaf

$$0 \longrightarrow \mathcal{O}_G^2 \longrightarrow \mathcal{O}_G(1)^3 \longrightarrow \mathcal{I}_S(3) \longrightarrow 0$$

From this we obtain as always that these congruences describe a Hilbert scheme that is smooth, irreducible and unirational of dimension 24.

Their geometric description is given in [11] as those lines that meet corresponding lines of three pencils.

Congruences of type 12).

They are complete intersection of a linear and a cubic complexes, thus providing an exact sequence

$$0 \longrightarrow \mathcal{O}_G \longrightarrow \mathcal{O}_G(1) \otimes \mathcal{O}_G(3) \longrightarrow \mathcal{I}_S^3(4) \longrightarrow 0$$

The Hilbert scheme of these congruences is smooth of dimension 34. On the other hand, this Hilbert scheme is also unirational and irreducible since it is dominated by an open subscheme of $\mathbb{P}(H^0(\mathcal{O}_G(1) \otimes \mathcal{O}_G(3))^{\vee})$.

Congruences of type 13).

We have a presentation for \mathcal{I}_S

$$0 \longrightarrow \mathcal{O}_G(-3)^3 \longrightarrow E_2(-2) \otimes \mathcal{O}_G(-2) \longrightarrow \mathcal{I}_S \longrightarrow 0$$

Therefore we conclude that these congruences form a smooth Hilbert scheme of dimension 27 that is irreducible and unirational.

Congruences of type 14).

Propositions 3.8 and 3.9 tell us that there are exact sequences

$$\begin{aligned} 0 \longrightarrow \mathcal{O}_S(H-K) \longrightarrow E_1^{\vee} \otimes \mathcal{O}_S \longrightarrow \mathcal{O}_S(K) \longrightarrow 0 \\ 0 \longrightarrow \mathcal{O}_G^2 \longrightarrow E_2(1) \otimes \mathcal{O}_G(3) \longrightarrow \mathcal{I}_S^3(4) \longrightarrow 0 \end{aligned}$$

The Hilbert scheme formed by these congruences is smooth of dimension 34, and we obtain as usual that it is also unirational and irreducible.

Congruences of type 15).

This congruence is described in [15] page 747 as those lines that are in one quadric of a fixed generic pencil of quadrics, or, equivalently, if C is the elliptic quartic that is the base locus of the pencil, is the congruence of bisecants to C . If $\mathcal{O}_{\mathbb{P}^3}^2 \longrightarrow \mathcal{O}_{\mathbb{P}^3}(2)$ is the morphism that defines such a pencil, pulling it back to the

incidence variety \mathcal{X} in $G \times \mathbb{P}^3$ and taking its direct image in G we obtain a morphism $\mathcal{O}_G^2 \longrightarrow S^2 E_2^V$ that fails to be an inclusion of bundles exactly in our congruence S . Thus, there is an exact sequence

$$0 \longrightarrow \mathcal{O}_G^2 \longrightarrow S^2 E_2^V \longrightarrow \mathcal{J}_S(3) \longrightarrow 0$$

The Hilbert scheme of this congruences is given by an open subscheme of $Gr(1, \mathbb{P}(H^0(S^2 E_2^V))) = Gr(1, \mathbb{P}(H^0(\mathcal{O}_{\mathbb{P}^3}(2))^V)) = Gr(1, 9)$, so that it is smooth, rational and irreducible of dimension 16.

Congruences of type 16).

There exists an exact sequence

$$0 \longrightarrow \mathcal{O}_G^4 \longrightarrow E_2(1) \otimes E_2(1) \otimes \mathcal{O}_G(1) \longrightarrow \mathcal{J}_S(3) \longrightarrow 0$$

The Hilbert scheme described by these congruences is smooth of dimension 28, and it is also unirational and irreducible because it is dominated by an open subset of $Gr(3, \mathbb{P}(H^0(E_2(1) \otimes E_2(1) \otimes \mathcal{O}_G(1))^V))$.

Congruences of type 17).

The congruence S is a double covering of the Veronese surface in \mathbb{P}^4 and therefore there is an exact sequence

$$0 \longrightarrow \mathcal{O}_G^3 \longrightarrow p^* \Omega_{\mathbb{P}^4}(2) \longrightarrow \mathcal{J}_S(3) \longrightarrow 0$$

where p is the composed morphism $G \subset \mathbb{P}^5 \longrightarrow \mathbb{P}^4$. The cohomology of \mathcal{J}_S is now easily calculated from the projection formula since $p_* p^* \mathcal{O}_G = \mathcal{O}_{\mathbb{P}^4} \otimes \mathcal{O}_{\mathbb{P}^4}(-1)$.

The Hilbert scheme of these congruences is smooth of dimension 26, and it is unirational and irreducible.

Congruences of type 18).

There is an exact sequence

$$0 \longrightarrow \mathcal{O}_G^4 \longrightarrow E_1(1) \otimes E_2(1) \otimes \mathcal{O}_G(1) \longrightarrow \mathcal{J}_S(3) \longrightarrow 0$$

We also get that these congruences describe a smooth, unirational and irreducible Hilbert scheme of dimension 30.

Congruences of type 19).

Since these congruences are complete intersections of two quadratic complexes, there is an exact sequence

$$0 \longrightarrow \mathcal{O}_G \longrightarrow \mathcal{O}_G(2) \otimes \mathcal{O}_G(2) \longrightarrow \mathcal{I}_S(4) \longrightarrow 0$$

The Hilbert scheme of these congruences is smooth of dimension 36, and again it is also rational and irreducible, since it is parametrized by an open subset of $Gr(2, H^0(\mathcal{O}_G(2)^2))$.

Congruences of type 20).

They are complete intersections of linear and quartic complexes, thus providing an exact sequence

$$0 \longrightarrow \mathcal{O}_G \longrightarrow \mathcal{O}_G(1) \otimes \mathcal{O}_G(4) \longrightarrow \mathcal{I}_S(5) \longrightarrow 0$$

The Hilbert scheme of these congruences is smooth of dimension 59, one less than the expected dimension. As in type 6), this Hilbert scheme is rational and irreducible.

§4.2. Smooth congruences of degree nine.

This section handles essentially the same techniques as §4.1, but we make a distinction since the work of classification was already done by Verra in [48],^(*) so that our task here is just to find resolutions for the ideal sheaves of the congruences to describe their Hilbert scheme. The list found by Verra, keeping the notations in §4.1, is the following:

(*) The congruence of type 25) is missing in Verra's list. This was communicated to us by Mark Gross, who has also now a complete classification up to degree 10.

	(d_1, d_2)	π	q	p_g	Description	Embedding
21)	(3,6)	5	0	0	$\tilde{\mathbb{P}}^2(x_1, x_2, \dots, x_{10})$	$ 7L-2E_1-2E_2-\dots-2E_{10} $
22)	(4,5)	5	0	0	$\tilde{\mathbb{P}}^2(x_1, x_2, \dots, x_{12})$	$ 6L-2E_1-\dots-2E_5-E_6-\dots-E_{12} $
23)	(4,5)	6	0	1	$\tilde{X}(x)$ $X=K3$ of deg 10 in \mathbb{P}^6	$ H_X-2E $
24)	(4,5)	12	0	8	Surface of general type with $K^2=17$	
25)	(3,6)	4	1	0	Conic bundle over a smooth plane cubic	

(Note that p_g and K^2 for type 24 are not correct in [48]).

We study now in more detail each of these types of congruences.

Congruences of type 21).

We see that $\omega_S(1)=\mathcal{O}_S(4L-E_1-E_2-\dots-E_{10})$ is generated by its five global sections, producing (as described in section §2.3) an exact sequence

$$0 \longrightarrow \mathcal{O}_G^5 \longrightarrow F \longrightarrow \mathcal{I}_S(3) \longrightarrow 0$$

where F is a rank six bundle with $h^3(F(-4)) = h^4(F(-4)) = 0$.

We first observe that S is not contained in any quadratic complex. Indeed, if it is, we can link it to a $(3,0)$ congruence S' by the complete intersection of this quadratic and another cubic complexes. There would be an exact sequence

$$0 \longrightarrow F^V(-2) \longrightarrow \mathcal{O}_G(-2)^6 \oplus \mathcal{O}_G(-3) \longrightarrow \mathcal{I}_{S'} \longrightarrow 0$$

showing that S' is not in a linear complex (since $h^0(\mathcal{I}_{S'}(1)) = h^1(F^V(-1)) = h^3(F(-3)) = h^3(\mathcal{I}_{S'}) = p_g = 0$). Hence, by [17] Theor. 6.5., S' is just a triple structure on an α -plane X_1 given by $\mathcal{I}_{S'} = \mathcal{I}_{X_1}^2$. Hence, S would contain a fundamental curve (a plane conic and a plane cubic, in fact), contradicting the proof of Theorem 4.1 quoted below.

Therefore, we have

$$\begin{aligned} h^1(F(-1)) &= h^1(\mathcal{I}_S(2)) = 0 \text{ by Riemann-Roch} \\ h^2(F(-2)) &= h^2(\mathcal{I}_S(1)) = h^1(\mathcal{O}_S(1)) = 0 \text{ also by Riemann-Roch} \\ h^3(F(-3)) &= h^3(\mathcal{I}_S) = p_g = 0 \\ h^4(F(-4)) &= 0 \end{aligned}$$

$$\begin{aligned}
h^1(F^\vee) &= h^3(F(-4)) = 0 \\
h^2(F^\vee(-1)) &= h^2(F(-3)) = h^2(\mathcal{I}_S) = q = 0 \\
h^3(F^\vee(-2)) &= h^1(F(-2)) = h^1(\mathcal{I}_S(1)) = 0 \\
h^4(F^\vee(-3)) &= h^0(F(-1)) = h^0(\mathcal{I}_S(2)) = 0
\end{aligned}$$

that shows as usual that F has no intermediate cohomology. Applying Prop. 1.3 we deduce that the only possibility is

$$F = E_2(1) \otimes E_2(1) \otimes E_2(1)$$

Lemma 2.3 tells us that the Hilbert scheme of these congruences is smooth of dimension 27. Since it is dominated by an open subscheme of $Gr(4, \mathbb{P}(H^0(E_2(1) \otimes E_2(1) \otimes E_2(1))^\vee))$, we also conclude that this Hilbert scheme is unirational and hence irreducible.

Congruences of type 22).

We see that $\omega_S(1) = \mathcal{O}_S(3L - E_1 - E_2 - \dots - E_5)$ is clearly generated by its five global sections. This yields a rank six vector bundle F fitting in an exact sequence

$$0 \longrightarrow \mathcal{O}_G^5 \longrightarrow F \longrightarrow \mathcal{I}_S(3) \longrightarrow 0$$

One can also check as in type 21) above that F has no intermediate cohomology. The only point to check is that S is not in a quadratic complex. If it is, we can link S to a locally Cohen-Macaulay (2,1) congruence not lying in a linear complex. There is no such a congruence (see again [17]), so that we conclude that F has no intermediate cohomology and deduce that it is

$$F = E_1(1) \otimes E_2(1) \otimes E_2(1)$$

These congruences, being rational, form a smooth Hilbert scheme of dimension 31, that is, as usual, unirational and irreducible.

Congruences of type 23).

Taking cohomology in the exact sequence defining a general hyperplane section

$$0 \longrightarrow \mathcal{O}_S(1) \longrightarrow \mathcal{O}_S(2) \longrightarrow \mathcal{O}_C(2) \longrightarrow 0$$

we get $h^0(\mathcal{O}_S(2)) \leq 19$ and thus $h^0(\mathcal{I}_S(2)) \geq 1$. Twisting with $\mathcal{O}_S(1)$ that sequence and taking

again cohomology we obtain that $h^0(\mathcal{O}_S(3)) \leq 41$ and $h^0(\mathcal{I}_S(3)) \geq 9$, so that S is linked by the complete intersection of a quadratic and a cubic complexes to (2,1) congruence S' that is in a linear complex (we do not know a priori whether S' is smooth and so dual of type 3)). Hence, S' is linked to a β -plane by the complete intersection of this linear complex and the above quadratic complex, just providing

$$0 \longrightarrow E_2(-2) \longrightarrow \mathcal{O}_G(-1) \otimes \mathcal{O}_G(-2) \otimes \mathcal{O}_G(-2) \longrightarrow \mathcal{I}_{S'} \longrightarrow 0$$

which in turn yields

$$0 \longrightarrow \mathcal{O}_G(-4) \otimes \mathcal{O}_G(-3) \longrightarrow E_2(-2) \otimes \mathcal{O}_G(-2) \longrightarrow \mathcal{I}_S \longrightarrow 0$$

The Hilbert scheme of these congruences is, after lemma 2.3 -checking from this exact sequence that both $\text{Ext}^2(\mathcal{I}_S, \mathcal{I}_S)$ and $\text{Ext}^3(\mathcal{I}_S, \mathcal{I}_S)$ vanish -smooth of dimension 37, and it is also unirational and irreducible since it is dominated by an open subscheme of $\mathbb{P}(\text{Hom}(\mathcal{O}_G(-4) \otimes \mathcal{O}_G(-3), E_2(-2) \otimes \mathcal{O}_G(-2)))^\vee$.

Congruences of type 24).

As usual for congruences that are in a linear complex, we obtain from Propositions 3.8 and 3.9 two exact sequences

$$\begin{aligned} 0 \longrightarrow \mathcal{O}_S(2H-K) \longrightarrow E_1^\vee \otimes \mathcal{O}_S \longrightarrow \mathcal{O}_S(K-H) \longrightarrow 0 \\ 0 \longrightarrow \mathcal{O}_G^2 \longrightarrow E_2(1) \otimes \mathcal{O}_G(4) \longrightarrow \mathcal{I}_S(5) \longrightarrow 0 \end{aligned}$$

and the second one provides us the vanishing of $\text{Ext}^2(\mathcal{I}_S, \mathcal{I}_S)$ and $\text{Ext}^3(\mathcal{I}_S, \mathcal{I}_S)$ so that we conclude from lemma 2.3 that the Hilbert scheme of these congruences is smooth of dimension 75. It is again unirational and irreducible.

Congruences of type 25)

The study of this family of congruences is not as standard as in the former cases. Such a study together with a bundle construction for presenting the ideal sheaf of these congruences will appear in a forthcoming paper by Mark Gross and the first author.

APPENDIX TO §4

§4.3. Examples of other congruences.

We include here some examples of congruences of degree at least ten that deserve to be at least mentioned, since they have some interest for various reasons.

Reye congruence.

This is a very well known congruence. It was the first known Enriques surface (and in fact, Fano thought that all Enriques surfaces had a model that was a Reye congruence). A modern reference for these congruences is [7]. What we intend to do here is to study the Hilbert scheme of Reye congruences by means of the techniques used in this §4.

Reye congruence is a (7,3) smooth congruence S that is an Enriques surface and has the following geometrical interpretation (cf. for example [15] pages 746-749): Fix a web of quadrics in \mathbb{P}^3 ; then the congruence consists of those lines which are in a pencil of quadrics of the web.

This clearly implies that this congruence is linked to a smooth congruence of bidegree (2,6) by the complete intersection of two cubic complexes; indeed, one can take these complexes to be defined by those lines contained in some pencil of quadrics inside a fixed net of the web (Such a complex is the degeneracy-locus of a morphism $\mathcal{O}_G^3 \rightarrow S^2 E_2^V$ so that it has degree $c_3 S^2 E_2^V = 3$). This (recalling from case 15 the resolution for the ideal sheaf of the (2,6) congruence) yields an exact sequence

$$0 \longrightarrow S^2 E_2 \longrightarrow \mathcal{O}_G^4 \longrightarrow \mathcal{I}_S(3) \longrightarrow 0$$

If we denote with F^V to the kernel of $\mathcal{O}_G^{10} \rightarrow S^2 E_2^V$ then we obtain a commutative diagram of exact sequences

$$\begin{array}{ccccccc}
 & & & 0 & & 0 & \\
 & & & \downarrow & & \downarrow & \\
 & & & \mathcal{O}_G^6 & \xrightarrow{\quad} & \mathcal{O}_G^6 & \\
 & & & \downarrow & & \downarrow & \\
 0 & \longrightarrow & S^2 E_2 & \longrightarrow & \mathcal{O}_G^{10} & \longrightarrow & F \longrightarrow 0 \\
 & & \parallel & & \downarrow & & \downarrow \\
 0 & \longrightarrow & S^2 E_2 & \longrightarrow & \mathcal{O}_G^4 & \longrightarrow & \mathcal{J}_{S,G}(3) \longrightarrow 0 \\
 & & & & \downarrow & & \downarrow \\
 & & & & 0 & & 0
 \end{array}$$

showing that S is the dependency locus of six sections of the rank seven vector bundle F (which is generated by its ten sections).

The Hilbert scheme of Reye congruences is, from lemma 2.2 and after checking some cohomology vanishing, smooth of dimension 24, and it is rational, since it is canonically isomorphic to an open subscheme of $Gr(5, \mathbb{P}(H^0(F)^\vee))$.

Special rational congruences.

The results here are not complete at all. They are inspired in a talk of K. Ranestad in the Mittag-Leffler Institute and in several conversations with him. What we intend to show is that the same kind of things as in \mathbb{P}^4 occur in G , but without checking the large amounts of details that would be needed to give conclusive results. Unfortunately, we do not know of any reference for these techniques.

A surface S in a projective space is said to be *special* if $h^1(\mathcal{O}_S(1)) \neq 0$. For a rational surface $S = \tilde{\mathbb{P}}^2(x_1, x_2, \dots, x_r)$ (hence $h^2(\mathcal{O}_S(1)) = 0$) this means that the space of sections embedding the surface in the projective space has not the expected dimension $\chi(\mathcal{O}_S(1)) = \binom{n+2}{2} - \sum \binom{m_i+1}{2}$, where $\mathcal{O}_S(1) = \mathcal{O}_S(nL - \sum m_i E_i)$ (keeping the notations of §4.1).

For example, consider a disjoint union \dot{X} of an α -plane and a β -plane. The exact sequence

$$0 \longrightarrow \mathcal{O}_G(-1) \longrightarrow \dot{E} \longrightarrow \mathcal{J}_{\dot{X}} \longrightarrow 0$$

shows us that a general linkage of \dot{X} by the complete intersection of a quadratic and a cubic complexes provides a smooth congruence S (apply lemma 3.3 using that $\dot{E}(2)$ is generated by its global sections) together with an exact sequence

$$0 \longrightarrow \dot{E}(-4) \longrightarrow \mathcal{O}_G(-2) \otimes \mathcal{O}_G(-3) \otimes \mathcal{O}_G(-4) \longrightarrow \mathcal{F}_S \longrightarrow 0$$

From this exact sequence and Prop. 2.1 we compute the following invariants for S : $d_1=d_2=5$, $\pi=7$, $K^2=-8$ and $p_g=q=0$. The adjunction map (defined by $K+H$) defines a surface S_1 in \mathbb{P}^6 of degree six, which must be a Del Pezzo surface, i.e., $S_1 = \tilde{\mathbb{P}}^2(x_1, x_2, x_3)$ and $H_1 = 3L - E_1 - E_2 - E_3$ so that S is $\tilde{\mathbb{P}}^2(x_1, x_2, \dots, x_{17})$ and its embedding in \mathbb{P}^5 is given by $H = 6L - 2E_1 - 2E_2 - 2E_3 - E_4 - E_5 - \dots - E_{17}$ (whose space of sections has expected dimension 5, but we see from the above sequence that $h^1(\mathcal{O}_S(1))=1$).

Let us examine how the points x_1, x_2, \dots, x_{17} are special. We consider a smooth plane quartic C passing through x_1, x_2, \dots, x_{14} (It is likely this happens, but we did not check that this is the case, for a general S , just as in [38]. If C does not exist, this is something special for the points).

Assume x_{15} , x_{16} and x_{17} are not in C . Therefore C has degree $\deg(C)=CH=7$ as a curve in \mathbb{P}^5 and genus $g(C)=3$. Hence, $\mathcal{O}_C(H)$ is not special, and from Riemann-Roch theorem we get $h^0(\mathcal{O}_C(H))=5$, which proves that $h^0(\mathcal{O}_S(H-C)) \geq 1$. Hence, there is a conic passing through $x_1, x_2, x_3, x_{15}, x_{16}, x_{17}$. Changing these last three points by any other choice of three points among x_4, x_5, \dots, x_{17} we would obtain that all x_1, x_2, \dots, x_{17} are in the same conic. This is absurd.

If we assume that one of the above three points, say x_{15} , is in C , then analogously we obtain $h^0(\mathcal{O}_S(H-C)) \geq 2$, and again there is a conic passing through $x_1, x_2, x_3, x_{15}, x_{16}, x_{17}$. And the same happens if we assume that two of the points are in C . Therefore, the 17 points are in C .

Hence we have that $\mathcal{O}_C(H)$ is special (to avoid the above contradiction) and since it has degree 4 in a curve of genus 3, then necessarily $\mathcal{O}_C(H) = \omega_C$ that in turn is equal to $\mathcal{O}_C(L)$ because C is a plane quartic. Therefore, $\mathcal{O}_C(5L - 2E_1 - 2E_2 - 2E_3 - E_4 - E_5 - \dots - E_{17}) = \mathcal{O}_C$ which implies that there exists a plane quintic passing through x_1, x_2, \dots, x_{17} and tangent to C at the points x_1, x_2 and x_3 .

We still know another example which is not complete. Consider again a disjoint union \dot{X} of an α -plane and a β -plane and now link it to a congruence S by a spinor congruence S_3 . From lemma 3.3, the general S will be smooth and we have

$$0 \longrightarrow \dot{E}(-4) \otimes E_2(-3) \longrightarrow \mathcal{O}_G(-3)^4 \otimes \mathcal{O}_G(-4) \longrightarrow \mathcal{F}_S \longrightarrow 0$$

showing that S has $d_1=6$, $d_2=5$, $\pi=8$, $K^2=-8$, $q=p_g=0$ and $h^1(\mathcal{O}_S(1))=1$. The adjunction map

provides a surface of degree nine in \mathbb{P}^7 and having sectional genus three. Another adjunction map will be likely (there are some cases to rule out, which is why this example is not complete) a blowing up of \mathbb{P}^2 . Thus, we would obtain that S is $\mathbb{P}^2(x_1, x_2, \dots, x_{17})$ embedded by $7L - 2E_1 - 2E_2 - \dots - 2E_7 - E_8 - E_9 - \dots - E_{17}$ and, as in the above example, in the generic case there would exist a quartic and a sextic in \mathbb{P}^2 intersecting in $2x_1, 2x_2, \dots, 2x_7, x_8, x_9, \dots, x_{17}$.

Possible abelian congruences.

If a smooth minimal abelian surface S is in G , checking the relations among its invariants given by Prop. 2.1 one sees that

$$d_1^2 + d_2^2 = 7(d_1 + d_2)$$

Since 7 (that is not congruent with 1 modulo 4) is a divisor of $d_1^2 + d_2^2$, then it should divide both d_1 and d_2 . Then one checks immediately that the only possibility is $d_1 = d_2 = 7$. In this case S would have a polarization of type (1,7) and $h^0(\mathcal{O}_S(1)) = 7$, so that it would be not linearly normal.

What is more interesting about the possible existence of such an abelian surface is that, according the construction of §2.3, there would exist a rank two vector bundle F on G appearing in an exact sequence

$$0 \longrightarrow \mathcal{O}_G \longrightarrow F \longrightarrow \mathcal{I}_S(4) \longrightarrow 0$$

This would provide a new rank two vector bundle on G . The only ones known are the universal bundles, the bundles \dot{E} , the direct sum of line bundles, the pull-back by a general projection to \mathbb{P}^4 of the Horrocks-Mumford bundle (see [24]) and all their twists. However, the possibility of existence of such an abelian surface is quite remote^(*).

§4.4. Some known classification theorems for congruences.

In order to give a complete view of smooth congruences, we quote here (now that enough examples have been explained) some known results about congruences that has been obtained by various mathematicians. The two first are originally due to Kummer, and the third to Fano (assuming the congruences not to have fundamental curve, but allowing them

(*) It has been proved recently by Marco Miele that indeed it does not exist.

to be singular). We give references for modern proofs.

Theorem 4.1 ([37]). *Let S be an irreducible congruence of bidegree $(1,n)$. Then S is given by one of the following*

a) *The $(1,3)$ congruence of bisecants of a twisted cubic.*

b) *The closure of the scheme defined by those lines that join different points p and q of L and C where L is a line of \mathbb{P}^3 and C is a rational curve of degree n intersecting L in $n-1$ points.*

Theorem 4.2 ([47]). *The only possible smooth congruences of bidegree $(2,n)$ are those of types 5,6,7,8,15 and the dual of type 3 in the list of §4.1.*

Theorem 4.3 ([47] or [8]). *Any smooth congruence of bidegree $(3,n)$ is one of the following: types 9,10,11,12,13,14,16 of §4.1; 21,25 of §4.2; the dual of types 4,7,8 of the list in §4.1; or the dual of the Reye congruence introduced in section §4.3.^(*)*

Proposition 4.4 ([8] or [16]). *Let S be a smooth congruence having an irreducible fundamental curve C . Then, one of the following holds.*

a) *C is a line (Hence S is contained in a linear complex and Prop. 3.8 gives all the possibilities).*

b) *C is a plane curve of degree at least two. In this case, if $d_1=d_2$ then S is a scroll.*

c) *C is a twisted cubic and S is the $(1,3)$ congruence of bisecants to C .*

d) *C is an elliptic quartic and S is the $(2,6)$ congruence of bisecants to C .*

In case b) it is a conjecture that the only possibility is that S is a scroll^(**). And, on the other hand, we have the following

Proposition 4.5 ([14], [31]). *Let S be a smooth scroll in G . Then S is of type 2,3,5 or 9 in the list of §4.1.*

(*) As observed before, the congruence of type 25) is missing in the given references. A revised proof will appear in a forthcoming paper by Mark Gross.

(**) It has been recently proved by the first author and Mark Gross that this conjecture is true if we add to the scrolls some special congruences in the family of congruences of type 25).

§5. A PROJECTION THEOREM FOR SMOOTH CONGRUENCES

Recall the following well-known theorem of Severi ([44]): *Let S be a smooth surface of \mathbb{P}^4 that can be obtained as a projection of another surface of \mathbb{P}^5 . Then S is the Veronese surface.*

We take care in this section of the analogous problem for G , namely, which are the smooth congruences of G that can be obtained as a projection from another smooth surface of $Gr(1,4)$? (The projections from $Gr(1,4)$ to G that we consider are those induced by linear projections from \mathbb{P}^4 to \mathbb{P}^3).

Since this is equivalent to classifying smooth congruences S for which $h^0(E_2^V \otimes \mathcal{O}_S) \geq 5$ or, equivalently, $h^1(E_2^V \otimes \mathcal{I}_S) \neq 0$, we can give a first partial answer by checking which congruences in our list of §4 verify that condition. We find the following examples:

(1) The (2,1) dual of a congruence of type 3) in the list of §4.1.

(2) The (2,2) of type 5).

(3) The Veronese surface (3,1), dual of the congruence of type 4), that is in fact projection from a surface of $Gr(1,5)$.

(4) The (3,2) congruence defined as the dual of type 7).

(5) The (3,3) congruence of type 10) in the mentioned list.

The main result we will prove in this section is the following

Theorem 5.1. *A smooth congruence is a projection of a smooth surface of $Gr(1,4)$ if and only if it is of one of the five types listed above.*

More in the flavor of Severi's theorem, we deduce immediately from this the following

Corollary 5.2. *The only smooth surface of $Gr(1,5)$ that projects smoothly to G from a generic line of \mathbb{P}^5 is the Veronese (3,1) congruence.*

§5.1. Some lemmas.

Let \tilde{S} be a smooth surface in $Gr(1,4)$. It has a bidegree (d_1, d_2) defined in an analogous way as for congruences in G . Namely, d_1 is the number of lines of \tilde{S} meeting a general fixed line and d_2 is the number of lines contained in a general hyperplane of \mathbb{P}^4 . This bidegree is clearly invariant under projection. We will say \tilde{S} is *degenerate* if the three-fold it defines in \mathbb{P}^4 is, i.e., is contained in a hyperplane.

We define Σ to be the subscheme of $Gr(2,4)$ parametrizing those planes Π of \mathbb{P}^4 such that the induced plane $\bar{\Pi}$ of $Gr(1,4)$ -defined by the lines contained in Π -meets \tilde{S} in a scheme of length bigger than one (maybe infinite). Clearly, a projection from a point x of \mathbb{P}^4 produces singular points in the corresponding S in G if and only if x is in a plane π of Σ . We now prove some lemmas.

Lemma 5.3. *If $d_1 \neq 3$ then, for any l in \tilde{S} , the corresponding line L of \mathbb{P}^4 is contained in some plane of Σ .*

Proof. Let C_l be the cubic cone in $Gr(1,4)$ with vertex l given by the intersection of $Gr(1,4)$ with its embedded tangent space in \mathbb{P}^9 (via the Plücker embedding) at l and parametrizing the lines of \mathbb{P}^4 that meet l . We distinguish two cases.

If \tilde{S} and C_l meet transversely at l , then they meet with multiplicity three, and since the length of the scheme $\tilde{S} \cap C_l$ is either d_1 or infinity, then there is another line L' of \tilde{S} meeting L . The span of L and L' is a plane of Σ .

If \tilde{S} and C_l do not meet transversely at l , then there is a generator g of the cone that is tangent to \tilde{S} at l . The line g will be given by lines contained in a plane Π and passing through a point of Π . Therefore the corresponding plane $\bar{\Pi}$ of $Gr(1,4)$, that contains g , is tangent to \tilde{S} at l , and hence Π is in Σ . ■

Lemma 5.4. *A projective irreducible three-dimensional variety X that contains a two dimensional family of planes is a \mathbb{P}^3 .*

Proof. Take any two points x and y in X . The family of planes in X passing through

x has at least dimension one, and therefore they cover X . Hence, one of these planes also contains y . In particular, the line joining x and y (which are arbitrary) is contained in X . We deduce from this that X is a \mathbb{P}^3 . ■

Lemma 5.5. *Let C be a curve of G that represents a developable ruled surface S in \mathbb{P}^3 (by this we mean that the embedded tangent line to C in \mathbb{P}^3 at each point is contained in G). Then, the ruled surface S is either a cone or the tangential developable to a curve C' in \mathbb{P}^3 .*

Proof. For each point x in C , since its embedded tangent line is in G , in particular it is in an α -plane, which is defined by a point p_x of \mathbb{P}^3 . If all points p_x coincide, then the ruled surface is a cone. If they describe a curve C' in \mathbb{P}^3 , we will show now by using local coordinates that S is the tangential developable to C' .

Indeed, choosing a local parameter t around a point of C , and suitable projective and Plücker coordinates, we can parameterize C as

$$p_{01} = 1$$

$$p_{ij} = f_{ij}(t) \text{ for other } i, j$$

(the f_{ij} being analytic functions related by the identity $f_{23} = f_{02}f_{13} - f_{03}f_{12}$). Hence the line in \mathbb{P}^3 represented by each x_t is the line passing through the points $(1, 0, -f_{12}(t), -f_{13}(t))$ and $(0, 1, f_{02}(t), f_{03}(t))$, which has equations

$$x_2 = f_{02}(t)x_1 - f_{12}(t)x_0$$

$$x_3 = f_{03}(t)x_1 - f_{13}(t)x_0$$

The condition for the embedded tangent line at each x_t of C , which has equations

$$p_{01} = 1$$

$$p_{ij} = f_{ij}(t) + \lambda f'_{ij}(t)$$

(where a prime means derivative with respect to t and λ is a complex parameter) is contained in G is given by

$$f'_{02}f'_{13} = f'_{03}f'_{12}$$

just identifying coefficients of λ^2 after substituting the above expressions in the Plücker relation $p_{01}p_{23} - p_{02}p_{13} + p_{03}p_{12} = 0$ (the identification of independent terms and coefficients in λ provides the above relation $f'_{02}f'_{13} = f'_{03}f'_{12}$ and the one obtained by

taking derivatives).

Hence, we can assume, swapping if necessary coordinates x_0 and x_1 , that there exists an analytic function g such that

$$f'_{12} = gf'_{02}$$

$$f'_{13} = gf'_{03}$$

The point defining the α -plane where x_t is in is the intersection point of the lines (when λ varies)

$$x_2 = (f_{02}(t) + \lambda f'_{02}(t))x_1 - (f_{12}(t) + \lambda f'_{12}(t))x_0$$

$$x_3 = (f_{03}(t) + \lambda f'_{03}(t))x_1 - (f_{13}(t) + \lambda f'_{13}(t))x_0$$

This is easily seen to be the point P_t of \mathbb{P}^3 of coordinates $(1, g(t), g(t)f_{02}(t) - f_{12}(t), g(t)f_{03}(t) - f_{13}(t))$. For points where $g'(t) \neq 0$, the tangent line in \mathbb{P}^3 at P_t to the curve C' defined by these points has parametric equations

$$x_0 = 1$$

$$x_1 = g(t) + \lambda g'(t)$$

$$x_2 = g(t)f_{02}(t) - f_{12}(t) + \lambda g'(t)f_{02}(t)$$

$$x_3 = g(t)f_{03}(t) - f_{13}(t) + \lambda g'(t)f_{03}(t)$$

and one checks immediately that this line coincides with the one defined by x_t .

Therefore, the curve C and the one in G defined by the tangents to C' coincide in an open (and dense, since g is constant if and only if the ruled surface is a cone) subset, and hence everywhere, just completing the proof. ■

Lemma 5.6. *The only non degenerate integral curve C of \mathbb{P}^3 that has no stationary bisecant is the twisted cubic. (A stationary bisecant is a line meeting C in two points such that the tangent lines of C at them are coplanar).*

Proof. At a general point p of C -that we assume to be the point $(1,0,0,0)$ after choosing suitable coordinates x_0, x_1, x_2, x_3 - the curve can be parameterized as

$$\begin{aligned} x_0 &= 1 + O(t) \\ x_1 &= t + O(t^2) \\ x_2 &= t^2 + O(t^3) \\ x_3 &= t^3 + O(t^4) \end{aligned}$$

(where $O(t^k)$ represents any expression in t of order at least k). Hence the curve of G defined by its tangents is parametrized locally at the point l representing the tangent at p by

$$\begin{aligned} p_{01} &= 1+O(t) \\ p_{02} &= 2t+O(t^2) \\ p_{03} &= 3t^2+O(t^3) \\ p_{12} &= t^2+O(t^3) \\ p_{13} &= 2t^3+O(t^4) \\ p_{23} &= t^4+O(t^5) \end{aligned}$$

where the p_{ij} are the Plücker coordinates associated to x_0, x_1, x_2, x_3 .

The Schubert variety of those lines that meet the tangent line of C at p (that is $x_2=x_3=0$) has equation $p_{23}=0$, so that has intersection multiplicity 4 at l . Since by assumption the set-theoretic intersection of this Schubert variety with the curve of tangents is only l , we conclude that the degree of the tangential developable is four. Then, checking all possible irreducible surfaces in \mathbb{P}^3 , one easily obtains that the only possibility is that C is a twisted cubic. ■

§5.2. Proof of the theorem.

Let \tilde{S} be a smooth surface of $Gr(1,4)$ of bidegree (d_1, d_2) . Let X denote the union in \mathbb{P}^4 of the lines of \tilde{S} and V the union of planes of Σ . We assume \tilde{S} can be projected smoothly to S in G , or equivalently, that V is not the whole \mathbb{P}^4 . We also assume that $d_1 \neq 3$ since smooth congruences of order three in G are classified (see Theor. 4.3), and the only ones of them coming from $Gr(1,4)$ are examples (3), (4) and (5) in the above list. Consider the following incidence diagrams.

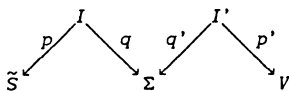

where $I = \{(l, \Pi) \in \tilde{S} \times \Sigma \mid L \subseteq \Pi\}$, $I' = \{(x, \Pi) \in \mathbb{P}^4 \times \Sigma \mid x \in \Pi\}$ and p, q, p' and q' are the obvious projections.

By lemma 5.3, p is surjective and V contains X as a component. Let Σ_0 be a component of Σ such that $q^{-1}(\Sigma_0)$ dominates \tilde{S} , and therefore such that $q'^{-1}(\Sigma_0)$ dominates X . Since \tilde{S} is nondegenerate, we deduce from lemma 5.4 that Σ_0 has dimension one. As a consequence, we conclude that each plane of Σ_0 contains a one-dimensional family of lines of \tilde{S} .

Projecting from a general point x outside X we obtain a smooth congruence S in G having a curve of singular planes -namely the projection of the planes of Σ_0 . Applying Prop. 4.4 to the dual congruence of S (which has a fundamental curve) we obtain that, with the exceptions of the Veronese (3,1), -that is our case (3) -and a congruence (6,2) -which is easily seen not to be projected from $Gr(1,4)$ since we know from §4.1 a resolution for \mathcal{J}_S -all these planes should meet in one point.

Therefore, there is a line M in \mathbb{P}^4 containing x such that all planes of Σ_0 meet M . Since x is not in X , M and X meet in a finite number of points, and from the irreducibility of Σ_0 we deduce that there is one of them -that we call p_0 -which is contained in all planes of Σ_0 . Hence X -the union of the planes in Σ_0 -is a cone with vertex p_0 over a ruled surface X' of \mathbb{P}^3 . Let us distinguish two cases.

Case a) The general plane Π of Σ_0 meets another plane Π' of Σ_0 along a line M . Then, through a general point x of M we can find at least one pair of lines of \tilde{S} , one of them in Π and the other in Π' , whose span is a plane of Σ meeting M in x and contained in the span $A \cong \mathbb{P}^3$ of Π and Π' . The union of all these planes as we move x in M will cover A , so that V contains A . Since V is not \mathbb{P}^4 , the spaces A cannot move in a one-dimensional family as we vary Π in Σ_0 . Hence X , which is covered by these spaces A , is a \mathbb{P}^3 , which is a contradiction.

Case b) Any two planes of Σ_0 meet only in p_0 , or equivalently, any two lines of the ruled surface X' are disjoint. We imitate now the argument in lemma 5.3 for the curve C' in $Gr(1,3)$ defining X' . For a generic line l of X' we consider the quadratic cone C_l in $Gr(1,3)$ of lines in \mathbb{P}^3 meeting l , that is, the intersection of $Gr(1,3)$ with its embedded tangent space in \mathbb{P}^5 at l . We distinguish two subcases.

Case b1) If X' is not developable, then C' and C_l meet transversely at l with multiplicity two. Since our assumption b) implies that they do not meet outside l , then X' has degree two and necessarily $X' = \mathbb{P}(\mathcal{O}_{\mathbb{P}^1}(1) \oplus \mathcal{O}_{\mathbb{P}^1}(1))$, $X = \mathbb{P}(\mathcal{O}_{\mathbb{P}^1} \oplus \mathcal{O}_{\mathbb{P}^1}(1) \oplus \mathcal{O}_{\mathbb{P}^1}(1))$ and \tilde{S} is in the three-fold $Y = \mathbb{P}(\mathcal{O}_{\mathbb{P}^1} \oplus \mathcal{O}_{\mathbb{P}^1}(-1) \oplus \mathcal{O}_{\mathbb{P}^1}(-1))$, embedded in $Gr(1,3)$ by the rank two vector bundle $\mathcal{T}_{Y/\mathbb{P}^1} \oplus \mathcal{O}_Y(-1)$, the relative tangent bundle twisted with the tautological line

bundle -we recall that \mathbb{P}^2 is embedded as a β -plane in a Grassmannian by the vector bundle $\mathcal{F}_{\mathbb{P}^2}(-1)$.

The Chow ring of Y is $\mathbb{Z}[t,s]/(t^2, s^3+2ts^2)$ where t is the pull-back of the hyperplane section in \mathbb{P}^1 and $s = c_1 \mathcal{O}_Y(1)$. The class of a point is ts^2 . If the class of \tilde{S} in Y is $at+bs$ we can calculate all the invariants of \tilde{S} in terms of a and b as follows.

From the exact sequence

$$0 \longrightarrow \mathcal{O}_Y(-s) \longrightarrow \mathcal{O}_Y \otimes \mathcal{O}_Y(-s) \otimes \mathcal{O}_Y(-s) \longrightarrow \mathcal{F}_{Y/\mathbb{P}^1} \otimes \mathcal{O}_Y(-s) \longrightarrow 0$$

we obtain a Chern polynomial for $\mathcal{F}_{Y/\mathbb{P}^1} \otimes \mathcal{O}_Y(-s)$

$$c_\lambda(\mathcal{F}_{Y/\mathbb{P}^1} \otimes \mathcal{O}_Y(-s)) = 1 + (s+2t)\lambda + (s^2+2ts)\lambda^2$$

so that

$$d_2 = c_2(\mathcal{F}_{Y/\mathbb{P}^1} \otimes \mathcal{O}_Y(-s)) = (s^2+2ts)(at+bs) = a$$

and hence

$$d_1 = H_{\tilde{S}}^2 - d_2 = (s+2t)^2(at+bs) = 2b$$

Using the exact sequence

$$0 \longrightarrow \mathcal{O}_Y(-2t) \longrightarrow \Omega_Y \longrightarrow \Omega_{Y/\mathbb{P}^1} \longrightarrow 0$$

(where the first term is the lift to Y of the canonical bundle of \mathbb{P}^1) and the value of the Chern polynomial of Ω_{Y/\mathbb{P}^1}

$$c_\lambda(\Omega_{Y/\mathbb{P}^1}) = 1 - (2t+3s)\lambda + (4ts+3s^2)\lambda^2$$

(obtained easily from $c_\lambda(\mathcal{F}_{Y/\mathbb{P}^1} \otimes \mathcal{O}_Y(-s))$ by dualizing and twisting) then one gets

$$c_\lambda(\Omega_Y) = 1 - (4t+3s)\lambda + (10ts+3s^2)\lambda^2 - 6ts\lambda^3$$

The exact sequence

$$0 \longrightarrow \mathcal{O}_Y(-at-bs) \longrightarrow \mathcal{O}_Y \longrightarrow \mathcal{O}_S \longrightarrow 0$$

and Riemann-Roch theorem for three-folds provide

$$\chi(\mathcal{O}_{\tilde{S}}) = \frac{(at+bs) \cdot c_2(\Omega_Y)}{12} + \frac{(at+bs) \cdot ((at+bs)+K_Y) \cdot (2(at+bs)+K_Y)}{12}$$

which, using the above computation of the Chern polynomial of Ω_Y and after some calculations, yields

$$\chi(\mathcal{O}_{\tilde{S}}) = \frac{6ab^2 - 4b^3 - 18ab + 6b^2 + 12a + 10b}{12}$$

Finally, from the adjunction formula one gets that the canonical divisor $K_{\tilde{S}}$ of \tilde{S} is given by

$$\omega_{\tilde{S}} = \omega_Y \otimes \mathcal{O}_{\tilde{S}}(at+bs) = \mathcal{O}_{\tilde{S}}((a-4)t+(b-3)s)$$

which in turn yields

$$K_{\tilde{S}}^2 = ((a-4)t+(b-3)s)^2(at+bs) = 3ab^2 - 2b^3 - 12ab + 4b^2 + 9a + 6b$$

and

$$K_{\tilde{S}} \cdot H_{\tilde{S}} = ((a-4)t+(b-3)s) \cdot (2t+s) \cdot (at+bs) = 2ab - 3a - 4b$$

Since \tilde{S} can be smoothly projected to S in G , they have the same invariants, and these are related by the formula of Prop.2.1, which in our case is

$$a^2 - 2ab + 2b^2 - a = 0$$

The discriminant of this polynomial (as a polynomial in a) is $-4b^2 + 4b + 1$, which must be a perfect square, so that the only possible values for b are 0 and 1.

We deduce immediately that the only solutions are $(a,b) = (1,0)$, which is an α -plane, hence degenerate, or $(a,b) = (1,1)$, which is our example (1), or $(a,b) = (2,1)$, which is example (2).

Case b2) If X' is developable, since any two lines are disjoint, it should be (by applying lemma 5.5) the tangential developable of a space curve without stationary bisecants. Such a curve can only be a twisted cubic (lemma 5.6), and therefore $X' = \mathbb{P}(\mathcal{O}_{\mathbb{P}^1}(2) \oplus \mathcal{O}_{\mathbb{P}^1}(2))$, $X = \mathbb{P}(\mathcal{O}_{\mathbb{P}^1} \oplus \mathcal{O}_{\mathbb{P}^1}(2) \oplus \mathcal{O}_{\mathbb{P}^1}(2))$ and \tilde{S} is a divisor of $Y = \mathbb{P}(\mathcal{O}_{\mathbb{P}^1} \oplus \mathcal{O}_{\mathbb{P}^1}(-2) \oplus \mathcal{O}_{\mathbb{P}^1}(-2))$. In the same way as in case b1), the variety Y is embedded in $Gr(1,4)$ by $\mathcal{T}_{Y/\mathbb{P}^1} \otimes \mathcal{O}_Y(-1)$ and has Chow ring $\mathbb{Z}[t,s]/(t^2, s^3 + 4ts^2)$. And again, if \tilde{S} has class $at+bs$, then we deduce as above

$$\begin{aligned} d_1 &= 4b \\ d_2 &= a \\ \chi(\mathcal{O}_{\tilde{S}}) &= \frac{6ab^2 - 8b^3 - 18ab + 18b^2 + 12a + 2b}{12} \\ K_{\tilde{S}}^2 &= 3ab^2 - 4b^3 - 12ab + 12b^2 + 9a \end{aligned}$$

$$K_S^2 H_S^2 = 2ab - 3a - 6b$$

which yields the relation

$$a^2 - 2ab + 10b^2 - a - 2b = 0$$

which has no solution in positive integers except $(a,b) = (0,0)$ or $(1,0)$, since we obtain a discriminant $-36b^2 + 12b + 1$. This completes the proof of Theor. 5.1. ■

§5.3. Smooth congruences with decomposable quotient bundle

As a sample of application of Theorem 5.1, we prove the following corollary

Proposition 5.7. *Let S be a smooth congruence such that $E_2^V \otimes \mathcal{O}_S$ is decomposable. Then, S is one of the following*

- a) $S = \mathbb{P}^2$ and $E_2^V \otimes \mathcal{O}_S = \mathcal{O}_{\mathbb{P}^2} \oplus \mathcal{O}_{\mathbb{P}^2}(1)$ (an α -plane $(1,0)$).
- b) $S = \mathbb{P}^1 \times \mathbb{P}^1$ and $E_2^V \otimes \mathcal{O}_S = \mathcal{O}_S(1,0) \oplus \mathcal{O}_S(0,1)$ $((1,1)$ of type 2) in §4.1).
- c) $S = \tilde{\mathbb{P}}^2(x)$ and $E_2^V \otimes \mathcal{O}_S = \mathcal{O}_S(L-E) \oplus \mathcal{O}_S(L)$ $((2,1)$ dual of type 3)).
- d) $S = \mathbb{P}^2$ and $E_2^V \otimes \mathcal{O}_S = \mathcal{O}_{\mathbb{P}^2}(1) \oplus \mathcal{O}_{\mathbb{P}^2}(1)$ $((3,1)$ dual of type 4)).

Proof. We write $E_2^V \otimes \mathcal{O}_S = L_1 \oplus L_2$ with $h^0(L_1) \leq h^0(L_2)$. Since $E_2^V \otimes \mathcal{O}_S$ is generated by its global sections, so are L_1 and L_2 . Using Theor. 5.1, there are four possibilities for their number of sections, that will correspond with the four cases in the statement.

a) $h^0(L_1) = 1$. Therefore, $L_1 = \mathcal{O}_S$ and hence all lines of the congruence pass through the point defined by $H^0(L_1)$. Thus, clearly the congruence is an α -plane.

b) $h^0(L_1) = h^0(L_2) = 2$. In this case, all lines of the congruence meet the two lines of \mathbb{P}^3 defined by $H^0(L_1)$ and $H^0(L_2)$. Then, S is the complete intersection of the two special linear complexes defined by these lines, and hence is the announced $(1,1)$ congruence.

c) $h^0(L_1) = 2$ and $h^0(L_2) = 3$. As above, the congruence is contained in the special linear complex defined by the line corresponding to $H^0(L_1)$. On the other hand, since $h^0(E_2^V \otimes \mathcal{O}_S) = 5$, we see from Theor. 5.1 that there are only four possibilities for S . One checks immediately that the $(2,1)$ congruence is the only one lying in a linear complex.

d) $h^0(E_2^V \otimes \mathcal{O}_S) = 6$ and from corollary 5.2 we obtain that S is the Veronese $(3,1)$. ■

§6. FINITENESS THEOREMS FOR FAMILIES OF CONGRUENCES

(Done in collaboration with M. Pedreira)

From Theor. 5.1, one should expect that it is very special for a smooth surface to be embeddable in G , in the same sense that it is also very special to have an immersion into \mathbb{P}^4 . In this section we will prove some results in this direction, showing that under certain conditions (fixed χ , or $K^2 \leq a\chi$ for a fixed $a < 6$, or not being of general type) the number of families of congruences verifying those conditions is finite.

The proof we give here is a literal translation of the one in [10] to our case, once we have the necessary ingredients. With this purpose, section §6.1 is devoted to provide bounds for the sectional genus of smooth congruences.

§6.1. Bounds for the genus of curves in Q_3 .

Definition. Let X be a variety contained in an irreducible hypersurface H of \mathbb{P}^r . We define the *postulation* of X in H to be the minimum integer s such that X is contained in the complete intersection of H with a hypersurface of \mathbb{P}^r of degree s .

We recall that a hypersurface of Q_n (the smooth hyperquadric of \mathbb{P}^{n+1}) is always the complete intersection of Q_n with a hypersurface of \mathbb{P}^{n+1} (thus having even degree $2s$). If $n=4$, we identify Q_4 with G and such a hypersurface is a complex of degree s .

Lemma 6.1. *If a congruence S of degree d is such that its general hyperplane section is contained in a surface Y of degree $2s$ of Q_3 and $d > 2s^2$ then S itself is contained in a complex of degree s .*

Proof. We can assume s to be the postulation, so that the general Y is irreducible. We fix a general Q_2 in Q_4 . Consider the pencil L of those Q_3 containing Q_2 and define X

as the incidence variety consisting of those pairs (x, Q_3) such that x is in Q_3 . There are natural projections $p: X \rightarrow L$ and $q: X \rightarrow Q_4$. We define $X_S = q^{-1}(S)$ and $X_{Q_2} = q^{-1}(Q_2)$.

Our hypothesis $d > 2s^2$ implies the uniqueness of the surface Y -since the restriction of Y to a general Q_2 is the only irreducible (s, s) curve containing the d points of $S \cap Q_2$. This means that $p_* \left(\mathcal{I}_{X_S, X}^{\otimes q} \otimes \mathcal{O}_{Q_4}(s) \right)$ is a line bundle that maps onto $p_* \left(\mathcal{I}_{X_S \cap X_{Q_2}, X}^{\otimes q} \otimes \mathcal{O}_{Q_4}(s) \right)$, which is the trivial bundle. Therefore $h^0 \left(\mathcal{I}_{X_S \cap X_{Q_2}, X}^{\otimes q} \otimes \mathcal{O}_{Q_4}(s) \right) = h^0 \left(\mathcal{I}_{S, Q_4}(s) \right)$ as wanted. ■

Given a curve of Q_3 , throughout this section, we will intersect only with tangent hyperplanes to Q_3 -i.e. elements of Q_3^V -so that we obtain groups of points in the quadric cone C_2 . For a general hyperplane, none of these points is the vertex of the cone, so that they can be regarded as points in the desingularization $\tilde{C}_2 = \mathbb{P}(\mathcal{O}_{\mathbb{P}^1} \oplus \mathcal{O}_{\mathbb{P}^1}(2))$ of C_2 . If $\pi: \tilde{C}_2 \rightarrow \mathbb{P}^1$ is the natural projection, the Picard group of \tilde{C}_2 is generated by the section C_0 of π having self-intersection -2 and a fiber F . With this notation, the map

$$\tilde{C}_2 \rightarrow C_2 \subset \mathbb{P}^3$$

is defined by $|C_0 + 2F|$. We prove now the following

Lemma 6.2. *Let C be an integral curve in Q_3 of degree d that is not contained in a surface of degree $2s$ and such that the set of points in \tilde{C}_2 corresponding to a generic intersection with a cone C_2 is contained in a curve of $|sC_0 + 2sF|$. Then*

$$d \leq 2s(s+1).$$

Proof. Let X be the incidence variety in $Q_3 \times Q_3^V$ and p and q the natural projections to Q_3 and Q_3^V . We define \mathcal{C} to be the inverse image by p of C , and V to be the vertex subvariety in X -i.e., the couples consisting of a point of Q_3 and the tangent hyperplane to Q_3 at this point. Let $b: \tilde{X} \rightarrow X$ be the blowing up of X along V . We will denote with $a \sim$ the liftings from X to \tilde{X} via b (e.g. $\tilde{q}: \tilde{X} \rightarrow Q_3^V$ is the map whose fibers are the blowing up \tilde{C}_2 of the corresponding fibers C_2 of q).

We can assume s to be the smallest integer satisfying our hypothesis. Since $\tilde{q}_* \tilde{p}^* (\mathcal{I}_{C, Q_3}(s)) \neq 0$, there exists an integer α , which we assume again to be minimal, such that $H^0(\mathcal{I}_{\tilde{C}, \tilde{X}}^{\otimes \alpha} \otimes \tilde{q}^* \mathcal{O}_{Q_3}(s) \otimes \tilde{q}^* \mathcal{O}_{Q_3^V}(\alpha)) = H^0(\tilde{q}_* \tilde{p}^* (\mathcal{I}_{C, Q_3}(s)) \otimes \mathcal{O}_{Q_3^V}(\alpha)) \neq 0$. Therefore, there exists a hypersurface \tilde{S} in \tilde{X} coming from S in X of minimal bidegree (s, α) -and hence integral

-that contains \tilde{C} and does not meet V . If we assume $d > 2s^2$, then for each C_2 in Q_3^V the curve in $|sC_0 + 2sF|$ containing $b^{-1}(C \cap C_2)$ is unique and corresponds to the intersection of \tilde{S} with the corresponding fiber of \tilde{q} .

We claim now that \tilde{p} maps \tilde{S} onto Q_3 . Indeed, as \tilde{p} has two-dimensional fibers, the image W of \tilde{S} has dimension at least two. Assume, for contradiction, that it is exactly two. Then, $\tilde{p}^{-1}(W)$ coincides with \tilde{S} since both schemes are integral of dimension four. Hence, $\alpha=0$, that in turn implies $H^0(\mathcal{F}_{C,Q_3}(s)) \neq 0$, which is absurd.

Therefore, $\tilde{p}|_{\tilde{S}}$ is surjective and its generic fiber is one-dimensional. On the other hand, it has two-dimensional fibers on C because of our assumption about its intersection with the cones C_2 . Thus, \tilde{C} is contained in the subscheme \tilde{C}' of \tilde{S} where $\tilde{p}|_{\tilde{S}}$ is not a smooth morphism. This subscheme is the locus where $\tilde{p}^* \mathcal{O}_{Q_3}(-s) \otimes \tilde{q}^* \mathcal{O}_{Q_3^V}(-\alpha) \otimes \mathcal{O}_{\tilde{S}} \longrightarrow \Omega_{\tilde{X}/Q_3}^V$ fails to be injective, so that we have a map

$$\beta: \Omega_{\tilde{X}/Q_3}^V \otimes \mathcal{O}_{\tilde{S}} \longrightarrow \mathcal{F}_{\tilde{C}', \tilde{S}} \otimes \tilde{p}^* \mathcal{O}_{Q_3}(s) \otimes \tilde{q}^* \mathcal{O}_{Q_3^V}(\alpha)$$

We fix now a generic element C_2 of Q_3^V and denote with Z the intersection of C with C_2 and with $\tilde{\Delta}$ and $\tilde{\Gamma}$ the intersection of \tilde{C} and \tilde{S} with the fiber \tilde{C}_2 of \tilde{q} corresponding to C_2 . Since we can consider Z naturally contained in $\tilde{\Delta}$, it is enough to show that $\tilde{\Delta}$ has length $\delta \leq 2s(s+1)$. Let N be the kernel appearing in the exact sequence

$$0 \longrightarrow N \longrightarrow \Omega_{\tilde{X}/Q_3}^V \otimes \mathcal{O}_{\tilde{C}_2} \longrightarrow \mathcal{F}_{\tilde{\Delta}, \tilde{\Gamma}} \otimes \mathcal{O}_{\tilde{C}_2}(sC_0 + 2sF) \longrightarrow 0$$

the last morphism being the restriction of β to \tilde{C}_2 .

We have exact sequences

$$0 \longrightarrow \Omega_{\tilde{X}/Q_3}^V \otimes \mathcal{O}_{\tilde{C}_2} \longrightarrow b^* \Omega_{X/Q_3}^V \otimes \mathcal{O}_{\tilde{C}_2} \longrightarrow \mathcal{E}xt^1(\omega_{C_0}, \mathcal{O}_{\tilde{C}_2}) = \mathcal{O}_{C_0} \longrightarrow 0$$

$$0 \longrightarrow \Omega_{X/Q_3}^V \longrightarrow \Omega_{Q_3^V \times Q_3}^V \otimes \mathcal{O}_X \longrightarrow p^* \mathcal{O}_{Q_3}(1) \otimes q^* \mathcal{O}_{Q_3^V}(1) \longrightarrow 0$$

the last one restricting to

$$0 \longrightarrow b^* \Omega_{X/Q_3}^V \otimes \mathcal{O}_{\tilde{C}_2} \longrightarrow \mathcal{O}_{\tilde{C}_2}^3 \longrightarrow \mathcal{O}_{\tilde{C}_2}(C_0 + 2F) \longrightarrow 0$$

We deduce from them that both $N(-C_0 + F)$ and N have no global sections. On the other

hand, if $H^0(N(C_0+2F))=0$, then we obtain

$$H^0(\mathcal{J}_{\Delta, \Gamma} \otimes \mathcal{O}_{C_2}((s+1)C_0+(2s+2)F)) \neq 0$$

concluding that

$$\delta \leq (sC_0+2F) \cdot ((s+1)C_0+(2s+2)F) = 2s^2+2s$$

Therefore we can assume $H^0(N(C_0+2F)) \neq 0$, so that we have $c_2(N((1-a)C_0+(2-b)F)) \geq 0$ for $(a,b) = (0,0), (0,1), (1,0)$ or $(1,1)$. Using the above exact sequences together with

$$0 \longrightarrow \mathcal{O}_{C_2}(C_0+2F) \longrightarrow \mathcal{O}_{C_2}((s+1)C_0+(2s+2)F) \longrightarrow \mathcal{O}_{\Gamma}((s+1)C_0+(2s+2)F) \longrightarrow 0$$

$$0 \longrightarrow \mathcal{J}_{\Delta, \Gamma}((s+1)C_0+(2s+2)F) \longrightarrow \mathcal{O}_{C_2}((s+1)C_0+(2s+2)F) \longrightarrow \mathcal{O}_{\Delta} \longrightarrow 0$$

we get $c_2(N(C_0+2F)) = 2s^2+2-\delta$. Hence, for the above four values of (a,b) we obtain inequalities

$$\begin{aligned} \delta &\leq 2s^2+2 \\ \delta &\leq 2s^2-2 \\ \delta &\leq 2s^2+s+2 \\ \delta &\leq 2s^2+s \end{aligned}$$

just completing the proof. ■

A first bound for the genus of curves in Q_3 can be obtained by considering a general projection to \mathbb{P}^3 and observing that if a curve of Q_3 is not in a surface of degree $2s$, then its projection in \mathbb{P}^3 is not in a surface of degree s . Therefore, applying the bound given in [18] (with its slight improvement in [10]), we obtain immediately the following:

Proposition 6.3. *Let C be a smooth curve in Q_3 of degree d and genus g that is not contained in a surface of degree strictly less than $2s$. Then*

$$s(2g-2) \leq d(d+s(s-4))$$

This bound, of course, is not sharp and it is not enough for our purposes, so that we will spend the rest of the section in proving the following result.

Proposition 6.4. *If a curve C of Q_3 of degree d and genus g is contained in an irreducible surface of degree $2s$, and $d > 2s(s-1)$, then*

$$s(2g-2) \leq d\left(\frac{d}{2} + s(s-3)\right)$$

The proof we are going to give here is completely analogous to the one given in [18] for curves in \mathbb{P}^3 . However, we found numerical obstructions to imitate it for proving the same bound for curves not contained in a surface of degree $2s$. Nevertheless, when such a bound is needed to prove the theorem, Proposition 6.3 is enough.

Let t be the postulation of C in Q_3 . Then, clearly $t \leq s$ and $2s(s-1) \geq 2t(t-1)$. Assume $t < s$ and that we know the result is true for t . Then $2g-2 \leq \frac{d}{t}(\frac{d}{2} + t(t-3))$ and, since C is contained in the intersection of two irreducible surfaces of Q_3 of degrees t and s , then $d \leq 2st$, which implies $\frac{d}{t}(\frac{d}{2} + t(t-3)) \leq \frac{d}{s}(\frac{d}{2} + s(s-3))$. Therefore we can assume s to be the postulation.

The key point to bound the genus of such a curve C is to define the numerical character for its generic intersection with a C_2 . Thus, we give the following:

Definition. Let Z be a finite length scheme in \tilde{C}_2 that is disjoint from C_0 . Let $X \in |sC_0 + 2sF|$ be a curve containing Z with s minimum. Then, if $\pi_* \mathcal{J}_{Z,X} = \bigoplus_{i=0}^{s-1} \mathcal{O}_{\mathbb{P}^1}(-n_i)$ the ordered set of integers $n_0 \geq n_1 \geq \dots \geq n_{s-1}$ is called the *numerical character* of Z .

Lemma 6.5. *The numerical character defined above verifies*

- a) $n_i \geq 2s-1$ for all $i=0, 1, \dots, s-1$
- b) If X is irreducible, $m_i - m_{i+1} \leq 1$ for all $i=1, 2, \dots, s-1$

(where m_i is the integral part of $\frac{n_i+1}{2}$).

Proof. Since s is the postulation we get the vanishing of $h^0(\mathcal{J}_{Z,X} \otimes \mathcal{O}_{C_2}((s-1)C_0 + 2(s-1)F)) = h^0(\mathcal{J}_{Z,X} \otimes \mathcal{O}_{C_2}((2s-2)F)) = h^0(\mathcal{J}_{Z,X} \otimes \pi^*(\mathcal{O}_{\mathbb{P}^1}(2s-2))) = h^0(\bigoplus_{i=0}^{s-1} \mathcal{O}_{\mathbb{P}^1}(2s-2-n_i))$. This proves a).

For b) we denote by V_m the image of $H^0(\mathcal{J}_{Z,X}(m))$ in the s -dimensional vector space $H^0(\mathcal{O}_{C_2})$, (where Σ is the intersection of X with a general generator F of C_2). The multiplication by an element of $H^0(\mathcal{O}_{C_2}(k))$ (which we can take vanishing in the vertex) defines an inclusion of V_m in V_{m+k} . From the definition of character we obtain for each $i=0, 1, \dots, s-1$, an element a_i in $H^0(\mathcal{J}_{Z,X}(m_i))$ such that if \bar{a}_i is its image in V_{m_i} then $\bar{a}_i, \bar{a}_{i+1}, \dots, \bar{a}_s$ is a basis for V_{m_i} . If $m_i - m_{i+1} \geq 2$ then, taking the equation x of a general hyperplane of \mathbb{P}^3 not passing through the vertex of C_2 , we obtain that \overline{xa}_j is in V_{m_i} for $j > i$. Therefore we get i relations vanishing on Z

$$xa_j = \sum_{k=j}^{s-1} \alpha_{jk} a_k$$

where we can take α_{jk} vanishing in the vertex. Since the homogeneous ring of X is an integral domain, this yields a relation in Z

$$\det(xI - (\alpha_{jk})) = 0$$

which defines a curve in $|(s-l)C_0 + 2(s-l)F|$ containing Z and with $s-l < s$, which is a contradiction. ■

Let C be a curve in Q_3 with postulation s and assume $d > 2s(s-1)$. From the above lemma, for the generic intersection Z with a C_2 we obtain a numerical character $n_0 \geq n_1 \geq \dots \geq n_{s-1}$ verifying a) and b) of lemma 6.5. We clearly have (a subindex + denoting positive part):

$$g = h^2(j_{C, Q_3}) \leq \sum_{r \geq 1} h^1(j_{Z, C_2}(r)) = \sum_{r \geq 1} h^1(j_{Z, C_2}(rC_0 + 2rF)) = \sum_{i, r} ((n_1 - 2r - 1)_+ - (2i - 2r - 1)_+)$$

This last sum is clearly less than the one corresponding to

$$n'_1 = t - 2i + 2s - 3 \quad \text{for } i = 0, 1, \dots, r-1$$

$$n'_1 = t - 2i + 2s - 2 \quad \text{for } i = r, r+1, \dots, s-1$$

where $d = st - r$ with $0 \leq r < s$. A straightforward calculation shows that the sum $\sum_{i, r} ((n'_1 - 2r - 1)_+ - (2i - 2r - 1)_+)$ is:

$$1 + \frac{\frac{d^2}{2} + s(s-3)d}{2s} - (s-r)\left(\frac{r}{2} - \frac{r}{4s} + \frac{1}{4}\right) \quad \text{if } t \text{ is odd}$$

$$1 + \frac{\frac{d^2}{2} + s(s-3)d}{2s} - \frac{r^2}{4s} - \frac{r(s-r)}{2} \quad \text{if } t \text{ is even}$$

This completes the proof of Prop. 6.4. ■

We want to mention that Mark Gross has obtained this very bound for curves not in a surface of degree strictly less than $2s$ when $s \leq 3$.

§6.2. Some technical lemmas

As said above, we imitate the proof given in [10]. Since our computations turn out to be certainly different (at certain parts due to the fact that the results in section §6.1 are not sharp enough), some of the proofs (the calculations, not the arguments) should be repeated here. For completeness, we decided to reproduce all of them, although most of them are a mere repetition of the corresponding ones in [10]. At the beginning of each proof we indicate its analogue in the paper by Ellingsrud and Peskine.

Lemma 6.6. *If S is a smooth congruence of degree $d=d_1+d_2$ larger than an integer depending only on χ , then S is contained in a complex of degree ≤ 8 .*

Proof. (Prop. 1 in [10]). If S is not in a complex of degree < 9 and $d > 128$, then from lemma 6.1 and Prop. 6.3 we obtain $9(2\pi-2) \leq d(d+45)$. Combining this with Prop. 2.1 and the inequalities $K^2 \leq 9\chi$ (if $\chi \geq 0$) and $d_1^2+d_2^2 \geq \frac{d^2}{2}$ (which we will use continuously) we get an inequality $d^2-414d \leq 108\chi$, which proves the lemma in case $\chi \geq 0$. If $\chi < 0$ we use $K^2 \leq 8\chi$. ■

The key result to be proved is the following:

Proposition 6.7. *For each positive integer σ there exists a polynomial P_σ of degree six with positive leading coefficient such that any smooth congruence S of postulation σ and degree $d > 2\sigma^2$ verifies $P_\sigma(\sqrt{d}) \leq \chi(O_S)$*

All the followings lemmas will be used to prove this, which is the result corresponding to Proposition 3 in [10].

Let S be a smooth congruence having postulation σ and let V be a complex of degree σ containing S . Set $N=N_{S/Q_4}$ and define

$$\mu = c_2(N(-\sigma H)) = d_1^2+d_2^2+\sigma(\sigma-3)d-\sigma(2\pi-2)$$

where H is, as usual, the hyperplane section. We have the following bound for μ :

Lemma 6.8. *In the above situation, $0 \leq \mu \leq \sigma^2 d$*

Proof. (Lemma 1 in [10]). The first inequality is just Prop. 6.4. applied to the general hyperplane section of S .

For the second one, we observe that the inclusion of S in V induces a morphism $\mathcal{O}_S(-\sigma H) \rightarrow N^V$ whose zero locus is the scheme of those points of S which are in the singular locus of V . Since σ is the postulation, this scheme is not all S , and we can write it as $D \cup Z$ where D is an effective divisor and Z has finite length r . Therefore we obtain a section of $N^V(\sigma H - D)$ vanishing exactly at Z . Thus,

$$r = c_2(N(D - \sigma H)) = \mu + (4 - 2\sigma)HD + D^2 + KD$$

On the other hand, from the universal sequence of $G = Q_4$ we obtain an epimorphism

$$H^0(\mathcal{O}_{\mathbb{P}^3}(1)) \otimes H^0(\mathcal{O}_{\mathbb{P}^3}(1)) \otimes \mathcal{O}_S \rightarrow E_1^V \otimes E_2^V \otimes \mathcal{O}_S = \Omega_{Q_4}^V \otimes \mathcal{O}_S \rightarrow N \rightarrow \mathcal{F}_{Z,S}(\sigma H - D)$$

so that, $\mathcal{F}_{Z,S}(\sigma H - D)$ being generated by global sections, we get

$$r \leq (\sigma H - D)^2 = \sigma^2 d - 2\sigma HD + D^2$$

which together with the above equality completes the proof, since clearly $(K + 4H) \cdot D \geq 0$ (for $K + 4H$ is very ample). ■

Lemma 6.9. *With the above notations, we have $\chi(\mathcal{F}_{S,V}(t)) =$*

$$\frac{\sigma t^3}{3} + t^2 \left(\frac{\sigma(\sigma - 4)}{2} - \frac{\delta}{2} \right) + t \left(\frac{\delta_1^2 + \delta_2^2 - \mu - \delta\sigma(\sigma - 4)}{2} + \frac{\sigma(2\sigma^2 - 6\sigma + 23)}{6} \right) - \frac{\sigma(\sigma^3 - 8\sigma^2 + 23\sigma - 28)}{12} - \chi$$
 where $\delta_i = \sigma t - d_i$ ($i=1,2$) and $\delta = \delta_1 + \delta_2 = 2\sigma t - d$. Furthermore, if X is a general hyperplane section of V , and C is the corresponding hyperplane section of S , then

$$\chi(\mathcal{F}_{C,X}(t)) = \frac{\delta_1^2 + \delta_2^2 - \mu - \delta\sigma(\sigma - 3)}{2\sigma} + 1 + \binom{\sigma}{2} + \binom{\sigma - 1}{3}$$

Proof. (Lemmas 2 and 4 in [10]). This is just substituting KH by μ and d_i by δ_i in the Riemann-Roch theorem. Indeed, for the first equality we use that

$$\chi(\mathcal{F}_{S,V}(t)) = \chi(\mathcal{O}_V(t)) - \chi(\mathcal{O}_S(t))$$

The first summand is obtained from the exact sequence

$$0 \rightarrow \mathcal{O}_G(t - \sigma) \rightarrow \mathcal{O}_G(t) \rightarrow \mathcal{O}_V(t) \rightarrow 0$$

which yields, using the fact that G can be consider as a smooth quadric in \mathbb{P}^5 ,

$$\chi(\mathcal{O}_V(t)) = \chi(\mathcal{O}_G(t)) - \chi(\mathcal{O}_G(t-\sigma)) = \binom{t+5}{5} - \binom{t+3}{5} - \left(\binom{t-\sigma+5}{5} - \binom{t-\sigma+3}{5} \right)$$

and, by Riemann-Roch theorem on S

$$\chi(\mathcal{O}_S(t)) = \chi + \frac{1}{2} \left(t^2(d_1+d_2) - tKH \right)$$

Making the substitutions

$$KH = 2\pi - 2d_1 - d_2 = \frac{d_1^2 + d_2^2 - \sigma(\sigma-3)(d_1+d_2) - \mu}{\sigma}$$

$$d_1 = \sigma t - \delta_1$$

$$d_2 = \sigma t - \delta_2$$

and simplifying we obtain the wanted result.

For the second equality we write

$$\chi(\mathcal{J}_{C,X}(t)) = \chi(\mathcal{O}_X(t)) - \chi(\mathcal{O}_C(t))$$

and these two terms are calculated as follows.

Since C is a smooth curve of genus π and degree d_1+d_2 we obtain from the Riemann-Roch theorem for curves

$$\chi(\mathcal{O}_C(t)) = t(d_1+d_2) - \pi + 1$$

and on the other hand, from the exact sequence

$$0 \longrightarrow \mathcal{O}_{Q_3}(t-\sigma) \longrightarrow \mathcal{O}_{Q_3}(t) \longrightarrow \mathcal{O}_X(t) \longrightarrow 0$$

we get

$$\chi(\mathcal{O}_X(t)) = \binom{t+4}{4} - \binom{t+2}{4} - \left(\binom{t-\sigma+4}{4} - \binom{t-\sigma+2}{4} \right)$$

Making again the above substitutions we complete the proof after a straightforward calculation. ■

Lemma 6.10. *In the above situation, if $\delta > 0$ and $\frac{\delta^2}{2} - \mu - \delta\sigma(\sigma-3) > 0$, then $H^0(\mathcal{J}_{C,X}(t)) \neq 0$.*

Proof. (Lemma 5 in [10]). From our hypothesis and lemma 6.9 we get $\chi(\mathcal{J}_{C,X}(t)) > 0$, so that we only need to prove the vanishing of $h^2(\mathcal{J}_{C,X}(t)) = h^0(\mathcal{J}_{C,X}^\vee(t))$, which is a

consequence of the fact that $c_1(\mathcal{F}_{C,X}^\vee(t)) = 2\sigma(\sigma-3)-\delta$ is negative, since $\delta(2\sigma(\sigma-3)-\delta) < 2\mu \leq 0$ from our hypothesis and lemma 6.8. ■

Lemma 6.11. *If $\pi:\tilde{X}\longrightarrow X$ is the normalization of a surface of degree 2σ in Q_3 , then for $\tau \geq \frac{14\sigma^3-9\sigma^2+13\sigma-18}{6}$ the sheaf $\omega^\vee = \mathcal{H}om(\omega, \mathcal{O}_{\tilde{X}})$ (where ω is the dualizing sheaf of \tilde{X}) is τ -regular.*

Proof. (Lemma C in [10]). Let \tilde{Y} be a general hyperplane section of \tilde{X} and consider the exact sequence

$$0 \longrightarrow \omega^\vee(-2) \longrightarrow \omega^\vee(-1) \longrightarrow \omega_{\tilde{Y}}^\vee \longrightarrow 0$$

(recall from the adjunction formula that $\omega^\vee \otimes \mathcal{O}_{\tilde{Y}} = \omega_{\tilde{Y}}^\vee(1)$)

Since \tilde{Y} is the desingularization of a curve Y of type (σ, σ) in the quadric, then $\omega_{\tilde{Y}}^\vee = \mathcal{O}_{\tilde{Y}}(\sigma-2)$ is $(2\sigma-2)$ -regular, since $h^1(\omega_{\tilde{Y}}^\vee(2\sigma-3)) = h^0(\omega_Y^\vee(3-2\sigma)) = h^0(\mathcal{O}_Y(-1)) = 0$. Hence, $\omega_{\tilde{Y}}^\vee$ is also $(2\sigma-2)$ -regular. For each integer n we look at the following long exact sequence obtained by taking cohomology in the exact sequence above

$$H^0(\omega^\vee(n-1)) \longrightarrow H^0(\omega_{\tilde{Y}}^\vee(n)) \longrightarrow H^1(\omega^\vee(n-2)) \longrightarrow H^1(\omega^\vee(n-1)) \longrightarrow H^1(\omega_{\tilde{Y}}^\vee(n))$$

For $n \geq 2\sigma-3$ the last term is zero, so that $h^1(\omega^\vee(n-2)) = h^1(\omega^\vee(n-1))$ if and only if the first map is surjective. If this is the case, we have a commutative square

$$\begin{array}{ccc} H^0(\omega^\vee(n-1)) \otimes H^0(\mathcal{O}_{\tilde{X}}(1)) & \longrightarrow & H^0(\omega_{\tilde{Y}}^\vee(n)) \otimes H^0(\mathcal{O}_{\tilde{Y}}(1)) \\ \downarrow & & \downarrow \\ H^0(\omega^\vee(n)) & \longrightarrow & H^0(\omega_{\tilde{Y}}^\vee(n+1)) \end{array}$$

the second column being surjective for $n \geq 2\sigma-2$ since $\omega_{\tilde{Y}}^\vee$ is $(2\sigma-2)$ -regular. Hence, the second row is also an epimorphism, so that $h^1(\omega^\vee(n-1)) = h^1(\omega^\vee(n))$ and iterating this we get $h^1(\omega^\vee(n-2)) = h^1(\omega^\vee(n-1)) = h^1(\omega^\vee(n)) = \dots$ and hence equal to zero.

Therefore, for $n \geq 2\sigma-4$ we have that either $h^1(\omega^\vee(n)) = 0$ or $h^1(\omega^\vee(n)) > h^1(\omega^\vee(n+1))$.

On the other hand, $H^0(\mathcal{O}_{\tilde{X}}(-1)) = 0$ and $H^1(\mathcal{O}_{\tilde{X}}(-2)) = 0$ (the latter from [31] Theor. 2, used in the form mentioned in §0). Serre duality provides thus the vanishing of $H^2(\omega(1))$ and $H^1(\omega(2))$. Applying the Mumford-Castelnuovo criterion we conclude that $\omega(3)$ is generated by its global sections. This implies that a general section of it vanishes on an integral curve Z and there is an exact sequence

$$0 \longrightarrow \omega^{\vee}(-3) \longrightarrow \mathcal{O}_{\tilde{X}} \longrightarrow \mathcal{O}_Z \longrightarrow 0$$

Hence, $h^1(\omega^{\vee}(-4)) = 0$ since trivially $h^0(\mathcal{O}_Z(-1)) = 0$ and, applying again the mentioned result in [31], we have that $h^1(\mathcal{O}_{\tilde{X}}(-1)) = 0$.

Therefore, one gets inequalities (the one in the middle by taking cohomology in the first exact sequence and using the natural inclusion $\mathcal{O}_{\tilde{Y}} \hookrightarrow \omega^{\vee}(\sigma-2)$ coming from $\omega_{\tilde{Y}} \longrightarrow \pi^* \omega_Y = \mathcal{O}_{\tilde{Y}}(\sigma-2)$)

$$h^1(\omega^{\vee}(2\sigma-5)) \leq \sum_{i=0}^{2\sigma-2} h^1(\omega_{\tilde{Y}}^{\vee}(2\sigma-4-i)) \leq \sum_{i=0}^{2\sigma-2} h^1(\mathcal{O}_Y(\sigma-2-i)) = \frac{14\sigma^3-9\sigma^2+\sigma}{6}$$

(the last equality comes from taking cohomology in the exact sequence $0 \longrightarrow \mathcal{O}_{Q_2}(-2-i) \longrightarrow \mathcal{O}_{Q_2}(\sigma-2-i) \longrightarrow \mathcal{O}_Y(\sigma-2-i) \longrightarrow 0$)

Because of the strict decreasing of $h^1(\omega^{\vee}(n))$ we obtain that $h^1(\omega^{\vee}(\tau-1)) = 0$ for $\tau \leq 1+2\sigma-4 + \frac{14\sigma^3-9\sigma^2+\sigma}{6} = \frac{14\sigma^3-9\sigma^2+13\sigma-18}{6}$ which, together with the fact that $h^2(\omega^{\vee}(n)) \leq h^2(\mathcal{O}_{\tilde{X}}(n-\sigma+3)) = h^0(\mathcal{O}_{\tilde{X}}(2\sigma-6-n)) = 0$ for $n \geq 2\sigma-5$, completes the proof by applying the Mumford-Castelnuovo criterion. ■

Lemma 6.12. *Let \mathcal{L} be a rank one reflexive $\mathcal{O}_{\tilde{X}}$ -module with \tilde{X} as in the above lemma. Denote by e the degree of the restriction of \mathcal{L} to the general hyperplane section of \tilde{X} . Let t be an integer such that ω^{\vee} is $(t-2)$ -regular and $t \geq 2\sigma$. Assume $H^0(\mathcal{L}) \neq 0$. Then*

- 1) $\mathcal{O}_{\tilde{X}}$ is t -regular
- 2) If $e > 0$, \mathcal{L} is (te) -regular.

Proof. (Lemma D in [10]). Since ω^{\vee} is $(t-2)$ -regular, we have in particular that $\omega^{\vee}(t-2)$ is generated by its global sections. Hence, a general section of $\omega^{\vee}(t-2)$ vanishes on a reduced curve C and provides an exact sequence

$$0 \longrightarrow \omega(2-t) \longrightarrow \mathcal{O}_{\tilde{X}} \longrightarrow \mathcal{O}_C \longrightarrow 0$$

Therefore, $h^1(\omega(1-t)) = 0$, since both $h^0(\mathcal{O}_C(-1))$ and $h^1(\mathcal{O}_{\tilde{X}}(-1))$ vanish (the second vanishing comes from [31] Theor. 2). By Serre duality, we obtain $h^1(\mathcal{O}_{\tilde{X}}(t-1)) = 0$.

On the other hand, since $\omega^{\vee}(t-2)$ is generated by its global sections, either $h^2(\mathcal{O}_{\tilde{X}}(t-2)) = h^0(\omega(t-2)) = 0$ or $\omega^{\vee}(t-2) = \mathcal{O}_{\tilde{X}}$. In the first case, from the Mumford-Castelnuovo criterion, we conclude that $\mathcal{O}_{\tilde{X}}$ is t -regular. In the second case,

since ω^\vee is $(t-2)$ -regular, we obtain that $\mathcal{O}_{\tilde{X}}$ is 0-regular and hence t -regular. This proves 1).

For 2) we write $\mathcal{L} = (\prod_1^r \mathfrak{a}_i)^\vee$ where \mathfrak{a}_i is the ideal sheaf in \tilde{X} of an integral curve (not necessarily different from each other) and proceed by induction on r .

Thus, first we assume that \mathcal{L} has a section vanishing on an integral curve C . Therefore, there exists an exact sequence

$$0 \longrightarrow \mathcal{L}^\vee \longrightarrow \mathcal{O}_{\tilde{X}} \longrightarrow \mathcal{O}_C \longrightarrow 0$$

and applying to it the functor $\mathcal{H}om(-, \omega(2))$ we get

$$0 \longrightarrow \omega(2) \longrightarrow \mathcal{H}om(\mathcal{L}^\vee, \omega(2)) \longrightarrow \omega_C(2) \longrightarrow 0$$

By Serre duality, $h^1(\omega(1)) = h^1(\mathcal{O}_{\tilde{X}}(-1)) = 0$ as observed above. Clearly, $h^1(\omega_C(1)) = 0$ so that $h^1(\mathcal{H}om(\mathcal{L}^\vee, \omega(1))) = 0$. On the other hand, the connecting homomorphism $H^1(\omega_C) \longrightarrow H^2(\omega)$ is the dual of $H^0(\mathcal{O}_{\tilde{X}}) \longrightarrow H^0(\mathcal{O}_C)$, which is an isomorphism (since C is connected). We conclude from this that $h^2(\mathcal{H}om(\mathcal{L}^\vee, \omega)) = 0$ and hence, from the Mumford-Castelnuovo criterion, that $\mathcal{H}om(\mathcal{L}^\vee, \omega(2))$ is generated by its global sections.

Therefore, one can find a morphism $\mathcal{L}^\vee \longrightarrow \omega(2)$ whose zero locus does not contain C . This provides a map $\varphi: \mathcal{O}_{\tilde{X}} \otimes \omega^\vee(-2) \longrightarrow \mathcal{L}$ whose cokernel R has finite length. Let us denote by M the kernel of φ and by A its image. We have an exact sequence

$$\begin{array}{ccccccc}
 0 & \longrightarrow & M & \longrightarrow & \mathcal{O}_{\tilde{X}} \otimes \omega^\vee(-2) & \xrightarrow{\varphi} & \mathcal{L} \longrightarrow R \longrightarrow 0 \\
 & & & & \searrow & \nearrow & \\
 & & & & & A & \\
 & & & & \nearrow & \searrow & \\
 & & & & 0 & & 0
 \end{array}$$

Since $\mathcal{O}_{\tilde{X}} \otimes \omega^\vee(-2)$ is t -regular (because of the hypothesis and the first part already proved) and $e > 0$, it is also (te) -regular, so that $h^1(\mathcal{O}_{\tilde{X}}(te-1) \otimes \omega^\vee(te-3)) = 0$ and $h^2(\mathcal{O}_{\tilde{X}}(te-2) \otimes \omega^\vee(te-4)) = 0$. Hence, $h^2(\mathcal{L}(te-2)) = h^2(A(te-2)) = 0$ (recall that R has finite support) and we are only left to prove $h^1(\mathcal{L}(te-1)) = 0$. For this, it suffices to show that $h^1(A(te-1)) = 0$, so that it is enough to prove $h^2(M(te-1)) = 0$.

Considering the restriction to a general hyperplane section \tilde{Y} of \tilde{X} and looking at the exact sequence

$$0 \longrightarrow M(-1) \longrightarrow M \longrightarrow M \otimes \mathcal{O}_{\tilde{Y}} \longrightarrow 0$$

we see that it is enough to show $h^1(M \otimes \mathcal{O}_{\tilde{Y}}(te)) = 0$. To prove this we will see that $\text{deg}(M \otimes \mathcal{O}_{\tilde{Y}}(te)) > 2g(\tilde{Y}) - 2$. Indeed, this degree can be obtained by restricting φ to \tilde{Y} and computing in the induced exact sequence

$$0 \longrightarrow M \otimes \mathcal{O}_{\tilde{Y}} \longrightarrow \mathcal{O}_{\tilde{Y}} \otimes \omega_{\tilde{Y}}^{\vee}(-1) \longrightarrow \mathcal{L} \otimes \mathcal{O}_{\tilde{Y}} \longrightarrow 0$$

so that we are left to prove $4g(\tilde{Y}) - 4 < 2\sigma te - 2\sigma - e$, which comes from our assumption $t \geq 2\sigma$ and the fact $2g(\tilde{Y}) - 2 \leq 2g(Y) - 2 = 2\sigma(\sigma - 2)$. This completes the proof in case $r = 1$.

For the general case, when $\mathcal{L} = (\prod_i \alpha_i)^{\vee} = (\prod_i \alpha_i^{\vee})^{\vee\vee}$ we write $\mathcal{L}' = (r \prod_i \alpha_i^{\vee})^{\vee\vee}$ and call e_i the degree of the curve whose ideal sheaf is α_i . One has $e = \sum e_i$ and from our induction hypothesis can assume \mathcal{L}' is $t(e - e_r)$ -regular and α_r^{\vee} is (te_r) -regular. What we have to prove is $h^i(\mathcal{L}' \otimes \alpha_r^{\vee}(te - i)) = 0$ for $i = 1, 2$.

If \mathfrak{b} is the cokernel of the natural morphism $\mathcal{O}_{\tilde{X}} \longrightarrow \mathcal{L} \longrightarrow \alpha_r^{\vee}$ then it is a torsion-free module supported on the curve whose ideal sheaf is α_r and it is (te_r) -regular (since it is a quotient of α_r).

Since $\mathcal{L}'(t(e - e_r))$ is generated by its global sections, then there exists an epimorphism $\mathcal{O}_{\tilde{X}} \longrightarrow \mathcal{L}'(t(e - e_r))$. Tensoring with $\mathfrak{b}(te_r - 1)$ we get $\mathfrak{b}(te_r - 1) \longrightarrow \mathcal{L}' \otimes \mathfrak{b}(te - 1)$, which implies the vanishing of $H^1(\mathcal{L}' \otimes \mathfrak{b}(te - 1))$. This last remark allows us to conclude by taking cohomology in the exact sequence

$$0 \longrightarrow \mathcal{L}' \longrightarrow \mathcal{L}' \otimes \alpha_r^{\vee} \longrightarrow \mathcal{L}' \otimes \mathfrak{b} \longrightarrow 0$$

Indeed, $h^1(\mathcal{L}' \otimes \alpha_r^{\vee}(te - 1)) = 0$ from the above vanishing and the (te) -regularity of \mathcal{L}' (in fact, $t(e - e_r)$ -regularity), and also $h^2(\mathcal{L}' \otimes \alpha_r^{\vee}(te - 2)) \leq h^2(\mathcal{L}'(te - 2)) = 0$ again from the $t(e - e_r)$ -regularity of \mathcal{L}' . ■

Lemma 6.13. *If \tilde{V} is the normalization of a complex V of degree σ , there exists an integer t_0 depending only on σ such that $\chi(\mathcal{O}_{\tilde{V}}(t)) \geq \chi(\mathcal{O}_V(t))$ if $t \geq t_0$ and therefore $\chi(\mathcal{I}_{S, \tilde{V}}(t)) \leq \chi(\mathcal{I}_{S, V}(t))$.*

Proof. (Lemmas A and 3 in [10]). We consider the following commutative diagram of exact sequences (defining Q and \tilde{Q} as cokernels)

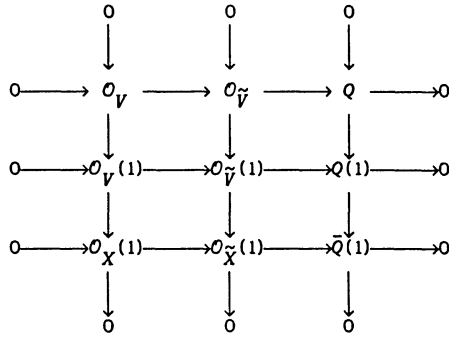

Take n to be the maximum of $\frac{14\sigma^3 - 9\sigma^2 + 13\sigma - 18}{6}$ and $2\sigma - 2$. We will prove that we can take $t_0 = 2n + 3$. From lemma 6.11, ω^V is n -regular, and from lemma 6.12, $\mathcal{O}_{\tilde{X}}$ is $(n+2)$ -regular. In particular, for any $m \geq n+1$ we have that $h^1(\mathcal{O}_{\tilde{X}}(m+1)) = 0$. From the exact sequence

$$0 \longrightarrow \mathcal{O}_{Q_3}(m+1-\sigma) \longrightarrow \mathcal{O}_{Q_3}(m+1) \longrightarrow \mathcal{O}_X(m+1) \longrightarrow 0$$

one also obtains $h^2(\mathcal{O}_X(m+1)) = 0$. Therefore, $h^1(\bar{Q}(m+1)) = 0$ and hence $\chi(\bar{Q}(m+1)) \geq 0$ which in turn implies from the last column in the diagram that $\chi(Q(m)) \geq \chi(Q(m+1))$.

Let x_0 be the minimum of the function $P(x)$ (where P is the quadratic polynomial such that $P(i) = \chi(Q(i))$). The above inequality says that x_0 is at most $n+1$. Since the parabola $y = P(x)$ is symmetric with respect to the line $y = x_0$ it will be enough to prove that $\chi(Q(-1)) \geq 0$.

Applying [31] Theor. 2, we have that $h^1(\mathcal{O}_{\tilde{X}}(-m)) = 0$ for $m \geq 1$ and hence $h^1(\mathcal{O}_{\tilde{V}}(-1)) \leq h^1(\mathcal{O}_{\tilde{V}}(-2)) \leq h^1(\mathcal{O}_{\tilde{V}}(-3)) \leq \dots$, which implies, since $h^1(\mathcal{O}_{\tilde{V}}(-m)) = 0$ for $m \gg 0$, that $h^1(\mathcal{O}_{\tilde{V}}(-1)) = 0$. Since \mathcal{O}_V has no intermediate cohomology, we obtain $h^1(Q(-1)) = 0$, that provides the wanted inequality $\chi(Q(-1)) \geq 0$ ■

We now fix t' to be the smallest integer verifying the hypothesis of lemma 6.10, i.e., such that $\delta' = 2\sigma t' - d > 0$ and $\frac{\delta'^2}{2} - \mu - \delta'\sigma(\sigma-3) > 0$. Hence, one of the following holds.

-Either $\delta' - 2\sigma = 2\sigma(t'-1) - d \leq 0$ and thus $\delta' \leq 2\sigma$

-Or $(\delta' - 2\sigma)^2 - 2\mu - 2(\delta' - 2\sigma)\sigma(\sigma-3) \leq 0$ and in this case we obtain $\delta'_1 - 2\sigma \leq \sigma(\sigma-3) + \sqrt{\sigma^2(\sigma-3)^2 + 2\mu}$

In any case, we have $\delta' \leq 2\sigma^2 + \sqrt{2\mu}$

Lemma 6.14. *With the above notations, we have an inequality*

$$\chi(\mathcal{J}_{S, \tilde{V}}(t')) \leq \sum_{n \leq t'} h^0(\mathcal{J}_{C, \tilde{X}}(n)) + \sum_{n > t'} h^1(\mathcal{J}_{C, \tilde{X}}(n))$$

Proof. (Lemma 6 in [10]). For each n we have an exact sequence

$$0 \longrightarrow \mathcal{J}_{S, \tilde{V}}(n-1) \longrightarrow \mathcal{J}_{S, \tilde{V}}(n) \longrightarrow \mathcal{J}_{C, \tilde{X}}(n) \longrightarrow 0$$

which provides

$$h^0(\mathcal{J}_{S, \tilde{V}}(n)) \leq h^0(\mathcal{J}_{C, \tilde{X}}(n)) + h^0(\mathcal{J}_{S, \tilde{V}}(n-1))$$

$$h^2(\mathcal{J}_{S, \tilde{V}}(n-1)) \leq h^1(\mathcal{J}_{C, \tilde{X}}(n)) + h^2(\mathcal{J}_{S, \tilde{V}}(n))$$

so that, applying the first inequality consecutively for $n = t_1, t_1 - 1, \dots$ and the second for $n = t_1 - 1, t_1, \dots$, and using the fact that $h^0(\mathcal{J}_{S, \tilde{V}}(-n)) = h^2(\mathcal{J}_{S, \tilde{V}}(n)) = 0$ for large n , we conclude that

$$h^0(\mathcal{J}_{S, \tilde{V}}(t_1)) \leq \sum_{n \leq t_1} h^0(\mathcal{J}_{C, \tilde{X}}(n))$$

$$h^2(\mathcal{J}_{S, \tilde{V}}(t_1)) \leq \sum_{n > t_1} h^1(\mathcal{J}_{C, \tilde{X}}(n))$$

The proof follows now from these two inequalities together with the trivial $\chi(\mathcal{J}_{S, \tilde{V}}(t_1)) \leq h^0(\mathcal{J}_{S, \tilde{V}}(t_1)) + h^2(\mathcal{J}_{S, \tilde{V}}(t_1))$ ■

Lemma 6.15. *In the situation of lemma 6.12, there exist positive constants A, B, A', B' depending only on σ such that*

$$\sum_{n \geq 0} h^0(\mathcal{L}(-n)) \leq Ae^3 + A'$$

$$\sum_{n \geq 0} h^1(\mathcal{L}(n)) \leq Be^3 + B'$$

Proof. (Lemma B in [10]). For the first inequality, by restricting to a general hyperplane section Y of X , and considering the exact sequence

$$0 \longrightarrow \mathcal{L}(-n-1) \longrightarrow \mathcal{L}(-n) \longrightarrow \mathcal{L} \otimes \mathcal{O}_{\tilde{Y}}(-n) \longrightarrow 0$$

we see that $h^0(\mathcal{L}(-n))=0$ for $n > n_0 = \left\lceil \frac{e}{2\sigma} \right\rceil$ and that $h^0(\mathcal{L}(-n_0+m)) \leq \sum_{i=1}^m h^0(\mathcal{L} \otimes \mathcal{O}_{\tilde{Y}}(-n_0+i)) \leq \sum_{i=1}^m (e+2\sigma(-n_0+i)+1) \leq \sum_{i=0}^m 2\sigma i = 2\sigma \binom{m+1}{2}$ and therefore

$$\sum_{n \geq 0} h^0(\mathcal{L}(-n)) \leq 2\sigma \binom{n_0+2}{3} \leq 6\sigma e^3 + 2\sigma$$

As for the second inequality, we define τ to be the minimum between $2\sigma-2$ and $\frac{14\sigma^3-9\sigma^2+13\sigma-18}{6}$, so that lemmas 6.11 and 6.12 imply that $\mathcal{O}_{\tilde{X}}$ is $(\tau+2)$ -regular and \mathcal{L} is $e(\tau+2)$ -regular. Thus, if we define $\tilde{\mathcal{L}}$ as the cokernel appearing in the exact sequence $0 \rightarrow \mathcal{O}_{\tilde{X}} \rightarrow \mathcal{L} \rightarrow \tilde{\mathcal{L}} \rightarrow 0$, then

$$\sum_{n \geq 1} h^1(\mathcal{L}(n)) \leq \sum_{n=1}^{\tau} h^1(\mathcal{O}_{\tilde{X}}(n)) + \sum_{n=1}^{e(\tau+2)-2} h^1(\tilde{\mathcal{L}}(n))$$

The first summand is bounded by

$$\sum_{n=1}^{\tau} \sum_{i=0}^n h^1(\mathcal{O}_{\tilde{Y}}(i)) \leq \sum_{i=0}^{\tau} (i+1)h^1(\mathcal{O}_{\tilde{Y}}(\tau-i))$$

which is a bound B' depending only on σ .

For the second summand, observing that $h^1(\tilde{\mathcal{L}}(e(\tau+2)-1))=0$ and from the exact sequences $0 \rightarrow \tilde{\mathcal{L}}(n-1) \rightarrow \tilde{\mathcal{L}}(n) \rightarrow \mathcal{C}^e \rightarrow 0$ we obtain a bound

$$\sum_{i=1}^{e(\tau+2)-2} h^1(\tilde{\mathcal{L}}(e(\tau+2)-1-i)) \leq \sum_{i=1}^{e(\tau+2)-2} e i = e \binom{e(\tau+2)-1}{2} \leq \frac{(\tau+2)^2 e^3}{2}$$

This completes the proof of this last technical lemma. ■

Finally, we prove Proposition 6.7. We distinguish two cases.

Case a) $t' \leq t_0$. We apply the inequality of Prop. 6.3 for $s=1$, together with the equality of Prop. 2.1 and, adding $d^3 - 8\sigma^3 t_0^3 \leq 0$ (since $t' \leq t_0$), obtain:

$$d^3 - \frac{7}{12}d^2 + \frac{3}{2}d - 8\sigma^3 t_0^3 \leq \chi \text{ if } \chi \geq 0 \text{ (using } K^2 \leq 9\chi)$$

$$d^3 - \frac{7}{8}d^2 + \frac{9}{4}d - 8\sigma^3 t_0^3 \leq \chi \text{ if } \chi < 0 \text{ (using } K^2 \leq 8\chi)$$

(we recall that t_0 only depends on σ).

Case b) $t' > t_0$. We apply Prop. 6.15 to $\mathcal{L} = \mathcal{J}_{\mathcal{O}_S, \chi}^{\sim}(t')$, and together with lemmas 6.10, 6.13, 6.14, we get

$$\frac{\sigma t'^3}{3} + \left(\frac{\sigma(\sigma-4)}{2} - \frac{\delta'}{2} \right) t'^2 + \left(\frac{\frac{\delta'}{2} - \mu - \delta'\sigma(\sigma-4)}{2\sigma} + \frac{\sigma(2\sigma^2-6\sigma+23)}{6} \right) t' - \frac{\sigma(\sigma^3-8\sigma^2+23\sigma-28)}{12} - \chi \leq (A+B)\delta'^3 + (A'+B')$$

Recalling $\delta' \leq 2\sigma^2 + \sqrt{2\mu} \leq 2\sigma^2 + \sigma\sqrt{2d}$ (the last inequality from lemma 6.8) and since $2t'\sigma = \delta' + d$ we obtain

$$\frac{d}{2\sigma} \leq t' \leq \frac{d}{2\sigma} + \frac{\sqrt{2d}}{2} + \sigma$$

Therefore we get, for example,

$$\frac{d^3}{24\sigma^2} - \left(\frac{d}{2\sigma} + \frac{\sqrt{2d}}{2} + \sigma \right)^2 \left(\sigma^2 + \frac{\sigma^2}{2}\sqrt{2d} \right) - \sigma^2 \left(\frac{d}{2\sigma} + \frac{\sqrt{2d}}{2} + \sigma \right) - \frac{\sigma(\sigma^3-8\sigma^2+23\sigma)}{12} - (A+B)(\sigma\sqrt{2d} + 2\sigma^2) - (A'+B') \leq \chi$$

Clearly we can find a polynomial that takes smaller values than the two polynomials appearing in cases a) and b). This completes the proof. ■

§6.3. Finiteness theorems

Theorem 6.16. *Let χ_0 be a fixed integer. Then there exists only a finite number of irreducible components of the Hilbert scheme of smooth congruences S verifying $\chi(\mathcal{O}_S) = \chi_0$.*

Proof. For fix $\chi(\mathcal{O}_S) = \chi_0$, lemma 6.6 and Prop.6.7 tell us that the degree is bounded. Therefore, the sectional genus π is also bounded (apply Prop. 6.3 for $s=1$), as well as K^2 , because of the relation in Prop 2.1. This proves the theorem. ■

This is implicitly proved in [10] for surfaces in \mathbb{P}^4 . The idea for this new statement of the theorem was given to us by C. Peskine. As a corollary we obtain the analogous to the main results in [10].

Theorem 6.17. *For any real number $a < 6$, there is a finite number of irreducible*

components of the Hilbert scheme of smooth congruences verifying $K^2 \leq a\chi$.

Proof. If we fix $a < 6$ and assume $K^2 \leq a\chi$, then Prop. 2.1 and the inequality of Prop. 6.3 in case $s=1$ provide an inequality $\chi \leq \frac{d(7d-18)}{4(6-a)}$, which together with lemma 6.6 (that allows us to assume S to be contained in a complex of degree ≤ 8) and Prop.6.7 shows that there are only a finite possible values for χ or d .

If the degree is bounded, then Prop.6.3 for $s=1$ tells us that π is also bounded. Thus, from Prop. 2.1, there is only a finite number of values for $\chi - 6K^2$. Using the bound $K^2 \leq 8\chi$ if $\chi < 0$, we get that in any case, there are finitely many possible values for χ . Finally we conclude by applying Theor. 6.16. ■

Theorem 6.18. *Except for a finite number of components, each component of the Hilbert scheme of smooth congruences consists of surfaces of general type.*

Proof. Let S be a smooth congruence that is not of general type. If it is not birationally ruled, then $\chi \geq 0$ and $K^2 \leq 0$, and thus, from the above theorem, there are only a finite number of families of such surfaces. If S is birationally ruled with $K^2 \leq 5$, we conclude again from Theorem 6.17. Then, we are left with the case of birationally ruled congruences with $K^2 \geq 6$.

From the Riemann-Roch theorem for such a surface we have that $h^0(-K) \geq \chi(-K) = 1 + K^2 > 0$ and therefore $HK < 0$, or equivalently $d > 2\pi + 2$. The equality of Prop 2.1 together with this inequality and $K^2 \leq 9$ yields $\frac{d^2}{2} - 7d + 10 \leq 0$, and thus $d \leq 12$. The argument in the above theorem completes the proof. ■

Remark. Also using this argument in Theorem 6.17 to conclude that if d is bounded, then there are finitely many possibilities for χ , would allow us to improve the statement of Prop. 6.7 and remove the hypothesis $d > 2\sigma^2$, thus getting exactly the analogous statement to Prop. 3 in [10].

We also remark that, as in \mathbb{P}^4 , complete intersections are a counterexample to Theorem 6.17 in case $a=6$. Indeed, if S is a complete intersection in G of two complexes of degrees a and b , we have that

$$K^2 = ((a+b-4)H)^2 = 2ab(a+b-4)^2$$

Also from the exact sequence

$$0 \longrightarrow \mathcal{O}_G(-a-b) \longrightarrow \mathcal{O}_G(-a) \oplus \mathcal{O}_G(-b) \longrightarrow \mathcal{O}_G \longrightarrow \mathcal{O}_S \longrightarrow 0$$

we get after a straightforward calculation

$$\chi(\mathcal{O}_S) = \frac{2a^3b + 3a^2b^2 + 2ab^3 - 12a^2b - 12ab^2 + 23ab}{6}$$

Thus,

$$\frac{K^2}{\chi(\mathcal{O}_S)} = 3 \frac{2a^2 + 3ab + 2b^2 - 12a - 12b + 23}{(a+b-4)^2}$$

that takes values arbitrarily close to 6, for example fixing a value for a and taking b arbitrarily large.

REFERENCES

- [1] *Arrondo, E. - Sols, I.*, Classification of smooth congruences of low degree, *Crelle J. reine angew. Math.* 393 (1989), 199-219.
- [2] *Arrondo, E. -Sols, I.*, Communication in the conference on Vector bundles and special projective embeddings, Bergen 1989.
- [3] *Aure, A. B.*, On surfaces in projective 4-space, Thesis, Oslo (1987).
- [4] *Barth, W. - Hulek, K.*, Monads and moduli of vector bundles, *Manuscripta Math.* 25 (1978), 323-347.
- [5] *Buchweitz, R.-O. - Eisenbud, D. - Herzog, J.*, Cohen Macaulay modules on quadrics, in Proceedings of a symposium on Singularities, representation of algebras and vector bundles, in Laurbrecht 1985, Springer LNM 1273 (1986), 58-95.
- [6] *Buchweitz, R.-O. - Greuel, G.-M. - Schreyer, F.-O.*, Cohen-Macaulay modules on hypersurface singularities II, *Invent. math.* 88 (1987), 165-182.
- [7] *Cossec, F.*, Reye congruences, *Transactions A.M.S.* 280 (1983), 738-749.
- [8] *Cossec, F. - Dolgachev, I. - Verra, A.*, Unpublished manuscript.
- [9] *Dolgachev, I. - Reider, I.*, on rank 2 vector bundles with $c_1^2=10$ and $c_2=3$ on Enriques surfaces, Proceedings of the US-USSR Symposium (Chicago 1989), Springer LNM 1479 (1991).
- [10] *Ellingsrud, G.- Peskine, C.*, Sur les surfaces lisses de \mathbb{P}_4 , *Invent.Math.*, 95 (1989), 1-11.
- [11] *Fano, G.*, Studio di alcuni sistemi di rette considerati come superficie dello spazio a cinque dimensioni, *Annali di Matematica (2)* 21 (1893), 141-193.

- [12] *Fano, G.*, Sulle congruenze di rette del terzo ordine prive di linea singolare, Att. Acc. di Scienze Torino 29 (1894), 474-493.
- [13] *Fano, G.*, Nuove ricerche sulle congruenze di rette del 3° ordine prive di linea singolare, Memoria della Reale Acad. Sc. Torino (2) 51 (1902), 1-79.
- [14] *Goldstein, N.*, Scroll surfaces in $Gr(1, \mathbb{P}^3)$, Conference on Algebraic Varieties of Small Dimension (Turin, 1965), Rend. Se. Mat. Univ. Polit. Special Issue (1987), 69-75.
- [15] *Griffiths, P. - Harris, J.*, Principles of Algebraic Geometry, Wiley Interscience, New York (1978).
- [16] *Gross, M.*, Surfaces in the Four-Dimensional Grassmannian, Ph. D. thesis, Berkeley (1990).
- [17] *Gross, M.*, Surfaces of degree 10 in $Gr(1, \mathbb{P}^3)$, Preprint.
- [18] *Gruson, L. - Peskine, C.*, Genre des courbes de l'espace projectif, in Proceedings of Tromsø conference on Algebraic Geometry. Springer LNM 687 (1977), 31-59.
- [19] *Hartshorne, R.*, Algebraic Geometry, Springer GTM 52 (1977).
- [20] *Hartshorne, R. - Hirschowitz, A.*, Cohomology of a general instanton bundle, Ann. Scient. E.N.S. 15 (1982), 365-390.
- [21] *Hernández, R. - Sols, I.*, On a family of rank 3 bundles on $Gr(1,3)$, Crelle J. reine angew. Math. 360 (1985), 124-135.
- [22] *Hernández, R. - Sols, I.*, Line congruences of low degree, Géométrie algébrique et applications II, Travaux en cours, Hermann Paris 1987, 141-154.
- [23] *Horrocks, G.*, Vector bundles on the punctured spectrum of a ring, Proc. London Math. Soc. 14 (1964), 689-713.
- [24] *Horrocks, G., - Mumford, D.*, A rank 2 vector bundle on \mathbb{P}^4 with 15,000 symmetries, Topology 12 (1973), 63-81.
- [25] *Ionescu, P.*, Variétés projectives lisses de degrés 5 et 6, C.R.A.S. 293 n°15 (1981), 685-687.
- [26] *Ionescu, P.*, Embedded projective varieties of small invariants I, in Proceedings of the Week of Alg. Geom. Bucharest, Springer LNM 1056 (1984), 142-186.
- [27] *Ionescu, P.*, Embedded projective varieties of small invariants II, Revue Rom. Math. Pure. Appl. 31 (1986), 539-544.
- [28] *Jessop, A*, A treatise on the line complex, 1903, New edition, Chelsea Publishing Company, New York, 1969.

- [29] *Knörrer, H.*, Cohen-Macaulay modules on hypersurface singularities I, *Invent. Math.* **88** (1987), 153-164.
- [30] *Kummer, E. E.*, Über die algebraischen Strahlensysteme insbesondere über die ersten und zweiten Ordnung, *Abh. Akad. Wiss. Berlin* (1866).
- [31] *Mumford, D.*, Pathologies III, *Am. J. Math.* **89** (1967), 94-104.
- [32] *Ottaviani, G.*, Critères de scindage pour les fibrés vectoriels sur les grassmanniennes et les quadriques, *C.R.A.S. t. 105*, (1987), 257-260.
- [33] *Papantonopoulou, A.*, Embeddings in $G(1,3)$, *Proc. A.M.S.* **95** (1983), 583-586.
- [34] *Papantonopoulou, A.*, Corrigendum to Embeddings in $G(1,3)$, *Proc. A.M.S.* **95** (1985), 533-536.
- [35] *Papantonopoulou, A.*, Minimal surfaces in the 4-quadric, To appear in *Bull. Greek Math. Soc.*
- [36] *Peskine, C. - Szpiro, L.*, Liaison des variétés algébriques, *Inv. Math.* **26** (1974), 271-302.
- [37] *Ran, Z.*, Surfaces of order 1 in grassmannians, *Crelle J. reine angew. Math.* **368** (1986), 119-126.
- [38] *Ranestad, K.*, On smooth surfaces of degree 10 in projective fourspace. Preprint.
- [39] *Rao, A. P.*, Liaison among curves in \mathbb{P}^3 , *Inventiones Math.* **50** (1979), 205-217.
- [40] *Rao, A. P.*, Liaison equivalence classes, *Mathematische Annalen* **258** (1981), 169-173.
- [41] *Reye, T.* *Geometrie der lage*, 2nd ed. Leipzig (1882).
- [42] *Roth, L.*, On the projective classification of surfaces, *Proc. of London Math. Soc.*, **42** (1937), 142-170.
- [43] *Schumacher, R.*, Classification der algebraischen Strahlensysteme, *Math. Ann.* **37** (1890), 100-140.
- [44] *Severi, F.*, Intorno ai punti doppi impropri di una superficie generale dello spazio a quattro dimensioni, e a suoi punti tripli apparenti, *Rend. Cir. Mat. Palermo, II Ser.* **15** (1901), 33-51.
- [45] *Sommese, A.*, Hyperplane sections of projective surfaces I. The adjunction mapping, *Duke Math. Journal* **46** (1979), 377-401.
- [46] *Speiser, R.*, Transversality theorems for families of maps, in *Proceedings of 1986 Sundance conference*, Springer LNM 1311 (1988), 235-252.

[48] *Verra, A.*, Smooth surfaces of degree 9 in $G(1,3)$, *Manuscripta Math.* 62 (1988), 417-435.

[49] *Vogelaar, J.* Constructing vector bundles from codimension two subvarieties, Ph. D. thesis, Leiden (1978).