

CESAR CAMACHO

NICOLAAS H. KUIPER

JACOB PALIS

The topology of holomorphic flows with singularity

Publications mathématiques de l'I.H.É.S., tome 48 (1978), p. 5-38

http://www.numdam.org/item?id=PMIHES_1978__48__5_0

© Publications mathématiques de l'I.H.É.S., 1978, tous droits réservés.

L'accès aux archives de la revue « Publications mathématiques de l'I.H.É.S. » (<http://www.ihes.fr/IHES/Publications/Publications.html>) implique l'accord avec les conditions générales d'utilisation (<http://www.numdam.org/conditions>). Toute utilisation commerciale ou impression systématique est constitutive d'une infraction pénale. Toute copie ou impression de ce fichier doit contenir la présente mention de copyright.

NUMDAM

Article numérisé dans le cadre du programme
Numérisation de documents anciens mathématiques
<http://www.numdam.org/>

THE TOPOLOGY OF HOLOMORPHIC FLOWS WITH SINGULARITY

by CESAR CAMACHO ⁽¹⁾, NICOLAAS H. KUIPER ⁽²⁾ and JACOB PALIS ⁽¹⁾

Prologue and summary ⁽³⁾

The integrals of the differential equations defined by a holomorphic vector field F on a complex manifold are complex curves parametrized by \mathbf{C} . The corresponding action of \mathbf{C} is called a holomorphic flow and the complex curves are its orbits. These orbits, in general two-dimensional real surfaces, form a foliation $\mathcal{F}(F)$ with singularities at the zeroes of the vector field F . We study the topology of such foliations $\mathcal{F}(F)$, in particular near a singularity. A simple example on \mathbf{C}^2 , which is rather general from the point of view of topology as we will see later, is given by the differential equations in complex numbers:

$$\frac{dz_1}{dT} = -z_1, \quad \frac{dz_2}{dT} = iz_2,$$

with solution in $T = u + iv$:

$$z_1 = e^{-u-iv} w_1, \quad z_2 = e^{-v+iu} w_2,$$

through the point (w_1, w_2) . The solutions are real two-dimensional leaves of a foliation \mathcal{F} with singularity at $0 \in \mathbf{C}^2$. Special leaves (topologically cylinders) are the *coordinate axes* ($z_1 \neq 0 = z_2$) and ($z_2 \neq 0 = z_1$). We see that every other leaf is transversal to $|z_1| = r$, to $|z_2| = r$, and to the "sphere" $\sup_j |z_j| = r$ for $r > 0$. It is topologically a cone with (deleted) top at $0 \in \mathbf{C}^2$. Starting from any point (w_1, w_2) , it is seen to *wrap around the z_1 -axis while converging to it* for $u = 0$, $v \rightarrow \infty$:

$$z_1 = e^{-iv} w_1, \quad z_2 = e^{-v} w_2,$$

⁽¹⁾ Instituto de Matemática Pura et Aplicada, Rio de Janeiro.

⁽²⁾ Institut des Hautes Études Scientifiques, Bures-sur-Yvette.

This research was partially supported by CNPQ (Brásil) and CNRS (France).

⁽³⁾ The results of chapter I and II were announced by M. Jean Leray at the meeting of the Academie des Sciences of May 3, 1976 [2]. After completing this paper we learned that theorem 1 was also found in USSR. See Ilyashenko [15].

The authors are grateful for important critical remarks of the referee.

and that it *wraps around the z_2 -axis while converging to it* for $v=0$, $u \rightarrow \infty$:

$$z_1 = e^{-u} w_1, \quad z_2 = e^{iu} w_2.$$

Such leaves that wrap converging along two coordinate axes will be called *Poincaré leaves*, also in the more general case of linear differential equations, in normal form, on \mathbf{C}^m :

$$\frac{dz_j}{dT} = \lambda_j z_j, \quad z_j = e^{\lambda_j T} w_j, \quad j=1, \dots, m, \quad T \in \mathbf{C}.$$

If $m \geq 3$ a different kind of leaf to be called a *Siegel leaf* may arise. A Siegel leaf is a closed embedding of \mathbf{C} in \mathbf{C}^m with minimal distance $\|\zeta\| = \rho > 0$ to the origin $o \in \mathbf{C}^m$ at a point ζ . If we fix ζ , then the points in the leaf at distance $r > \rho$ from the origin form an embedded circle, because the distance to o has at most one critical point (ζ) on a leaf. For decreasing $\rho > 0$, moving ζ to $o \in \mathbf{C}^m$, but keeping $r=1$ fixed, we have the curious phenomenon that an increasing portion (with respect to length) of the embedded circle is very near to the axes and a point moving on the circle wraps around an axis a finite number of times, before going to the next. The finite number for the j -th axis can be defined as the number n_j of intersection points of the leaf with a small transversal section to the j -th axis. It now happens that the sequence of ratios $n_j / \sum_k n_k$ for $j=1, \dots, m$, has as accumulation points as $\zeta \rightarrow o \in \mathbf{C}^m$, that is as $\sum_k n_k \rightarrow \infty$, exactly the set of sequences of non-negative numbers (measures) c_1, \dots, c_m :

$$\Delta = \{c_1 \geq 0, \dots, c_m \geq 0 : \sum_j c_j = 1, \sum_j c_j \lambda_j^{-1} = 0\}.$$

Δ is a topological invariant of the foliation \mathcal{F} and it is the only one under the assumption that no two of $\lambda_1, \dots, \lambda_m$ are linearly dependent over \mathbf{R} . This is theorem I of chapter I. Note that Δ is empty in case o is not in the convex hull $\mathcal{H}(\lambda_1, \dots, \lambda_m)$ of $\lambda_1, \dots, \lambda_m$ in \mathbf{C} .

Let the foliation \mathcal{F} be a member of a family Φ , a topological space with a linear or at least a differentiable structure. \mathcal{F} is called *topologically stable of codimension $\leq d$* (or just *stable* in case $d=0$) in Φ , if all members in some neighborhood U of \mathcal{F} in Φ are completely classified up to homeomorphism by d linear or differentiable real functions.

Theorem I (chapter I) can now be expressed as follows: Let Φ_L be the set of foliations coming from linear vector fields on \mathbf{C}^m with $i \neq j \Rightarrow \lambda_i \notin \mathbf{R}\lambda_j$. The foliation \mathcal{F} is stable, respectively stable of codimension $2m-4$, in Φ_L , in case $o \notin \mathcal{H}(\lambda_1, \dots, \lambda_m)$, respectively $o \in \mathcal{H}(\lambda_1, \dots, \lambda_m)$.

Chapter II gives an application of the linear theory of chapter I to *holomorphic flows on the complex projective space $P = \mathbf{CP}(m)$* . As we recall and prove again in § 8 every vector field F on $\mathbf{CP}(m)$ arises naturally from a linear vector field $\sigma : \mathbf{C}^{m+1} \rightarrow \mathbf{C}^{m+1}$ as the quotient by the action of $\mathbf{C}^* = \mathbf{C} - \{0\}$ by scalar multiplication. At the $m+1$ singular points in P , $\mathcal{F}(F)$ has the topological invariants of chapter I. This gives the complete topological classification of the foliations of such flows: *Assuming that no three of the eigenvalues $\lambda_0, \dots, \lambda_m$ of σ are collinear in the complex plane \mathbf{C} , \mathcal{F} is stable, respectively stable of codimension $2m-4$, in case $\mathcal{H}(\lambda_0, \dots, \lambda_m)$ is an $(m+1)$ -gon, respectively an m -gon in \mathbf{C} . If*

more than one among $\lambda_0, \dots, \lambda_m$ are inside $\mathcal{H}(\lambda_0, \dots, \lambda_m)$, then the topological classification coincides with the classification under projective transformations taken together with complex conjugation of \mathbf{C} , and \mathcal{F} is “stable of codimension $2m-2$ ”.

This is theorem II. We recall that holomorphic vector fields are rare on algebraic smooth varieties that are different from the complex projective spaces $\mathbf{CP}(m)$. For a precise statement see Lieberman [8].

Consider now the larger class Φ of foliations of all holomorphic vector fields with an isolated singularity at $o \in \mathbf{C}^m$:

$$\begin{aligned} \frac{dz}{dT} = F(z) = \sigma z + R(z) \in \mathbf{C}^m, \quad z \in \mathbf{C}^m, \quad F(o) = o \\ \sigma z = (DF_0)(z), \end{aligned} \quad (1)$$

σ has eigenvalues $\lambda_1, \dots, \lambda_m$.

The problem of finding a *holomorphic local equivalence* between F and σ was considered by Poincaré [11] and Siegel [13], see also [1], [4], [12]:

Theorem of Poincaré. — Assume that $i \neq j \Rightarrow \lambda_i \notin \mathbf{R}\lambda_j$ and $o \notin \mathcal{H}(\lambda_1, \dots, \lambda_m)$. If no relation:

$$\lambda_j = \sum_{i=1}^m k_i \lambda_i, \quad k_i \in \mathbf{Z}_+, \quad \sum_{i=1}^m k_i \geq 2, \quad j = 1, \dots, m,$$

holds, then F is holomorphically equivalent to σ near $o \in \mathbf{C}^m$.

Theorem of Siegel. — Assume that $i \neq j \Rightarrow \lambda_i \notin \mathbf{R}\lambda_j$ and $o \in \mathcal{H}(\lambda_1, \dots, \lambda_m)$. Then for almost all $\Lambda = \{\lambda_1, \dots, \lambda_m\}$, with respect to Lebesgue measure, F is holomorphically equivalent to σ near $o \in \mathbf{C}^m$.

From these theorems we obtain easily in Chapter I, § 7, the characterization for local stability of F near $o \in \mathbf{C}^m$:

Corollary. — F is stable (of codimension zero) if and only if $i \neq j \Rightarrow \lambda_i \notin \mathbf{R}\lambda_j$ and $o \notin \mathcal{H}(\lambda_1, \dots, \lambda_m)$.

The sufficiency of this condition is *Guckenheimer's* [5] *stability theorem*: Any two foliations $\mathcal{F}(F)$ and $\mathcal{F}(F')$ of vector fields F and F' with singularity at $o \in \mathbf{C}^m$, and with spectra Λ of DF_0 and Λ' of DF'_0 in the Poincaré domain, are locally homeomorphic.

In chapters III and IV we study the local problem for the Siegel case:

$$o \in \mathcal{H}(\lambda_1, \dots, \lambda_m), \quad i \neq j \Rightarrow \lambda_i \notin \mathbf{R}\lambda_j.$$

We conjecture that the foliation $\mathcal{F}(F)$ near the isolated singularity of F at $o \in \mathbf{C}^m$ is homeomorphic to the foliation $\mathcal{F}(\sigma)$ of its linear part $\sigma = (DF)_0$. We prove this for $m=3$ in chapter III (theorem III) and find therefore with theorem I: *If $o \in \mathcal{H}(\lambda_1, \lambda_2, \lambda_3)$, then (the germ at o of) \mathcal{F} is stable of codimension two in the space Φ of (germs at zero of) foliations of holomorphic vector fields with singularity at zero.* This theorem is rather different from

classical results concerning *holomorphic equivalence* to linear or other normal forms, in which “small” and “zero divisors” play an important role (Poincaré, Siegel and others. Compare Brjuno [1]).

In chapter IV (and chapter III, § 11 and § 12 for $m=3$) we give a *weak normal form* for any F (see (1)) by proving the existence of a *holomorphic change of coordinates* after which the remainder $R(z)$ belongs to a specific simple class. In this weak normal form the union of all Poincaré leaves for $\mathcal{F}(F)$ is already in the same stratified union V of linear subspaces as for the corresponding linear case $\mathcal{F}(\sigma)$. This is a first step in the proof of our conjecture for $m \geq 4$, which we hope to give in another paper ⁽¹⁾.

I. — LINEAR FLOWS

1. Introduction and main theorem.

Let $\mathcal{F}(\sigma)$ be the holomorphic foliation or flow with singularity at o , defined by the vector field $F(z)$ in \mathbf{C}^m :

$$\frac{dz}{dT} = F(z) = \sigma z \in \mathbf{C}^m, \quad T \in \mathbf{C}, \quad \sigma \in \text{GL}(m, \mathbf{C}) \quad (2)$$

with real two-dimensional leaves:

$$z = e^{\sigma T} w, \quad w \in \mathbf{C}^m. \quad (3)$$

Set: spectrum $\sigma = \Lambda = \{\lambda_1, \dots, \lambda_m\} \subset \mathbf{C}$ (4)

$$\begin{aligned} \text{spectrum } 2\pi i \sigma^{-1} &= \hat{\Lambda} = \{\hat{\lambda}_1, \dots, \hat{\lambda}_m\} \\ \hat{\lambda}_j &= 2\pi i \lambda_j^{-1}. \end{aligned} \quad (5)$$

The *equivalence class* of $\hat{\Lambda} \subset \mathbf{C}$ under the natural action of $\text{GL}(2, \mathbf{R})$ in $\mathbf{C} = \mathbf{R}^2$ is denoted:

$$\eta(\sigma). \quad (6)$$

In § 2 we give the easy proof of the

Pre-theorem. — *If σ is diagonal, then the topology of $\mathcal{F}(\sigma)$ is completely determined by $\eta(\sigma)$.*

Already in case $m=2$ equality and even real dependence of two eigenvalues of σ complicates the topology of $\mathcal{F}(\sigma)$ very much. We therefore *assume* that any two eigenvalues are independent over \mathbf{R} :

$$i \neq j \Rightarrow \lambda_i \notin \mathbf{R} \lambda_j, \quad i, j = 1, \dots, m. \quad (7)$$

⁽¹⁾ *Added in proof* (May 1978): For a non linear flow F with singularity at $o \in \mathbf{C}^m$, we can now define the topological invariant Δ , and it depends, in the same way as before, only on the linear part of F at o . This is necessary but not sufficient to prove the conjecture also for $n \geq 4$. Dumortier and Roussarie [17] have important related results on linearization.

The *convex hull* of $\Lambda = \{\lambda_1, \dots, \lambda_m\}$ in \mathbf{C} is denoted $\mathcal{H}(\Lambda)$. The open set of unordered m -tuples $\{\Lambda : (7)\}$ consists of a connected component, the *Poincaré domain* $\{\Lambda : \mathfrak{o} \notin \mathcal{H}(\Lambda)\}$, and its complement, the *Siegel domain* ⁽¹⁾:

$$\{\Lambda : \mathfrak{o} \in \mathcal{H}(\Lambda)\}.$$

$\eta(\sigma)$ is topologically irrelevant in the case of the Poincaré domain (Guckenheimer) as we prove again (for later applications) by an explicit homeomorphism in § 6.

For the Siegel case the situation is different and we have (§ 5):

Main Theorem 1. — *If the spectrum of σ lies in the Siegel domain ((7) and $\mathfrak{o} \in \mathcal{H}(\Lambda)$), then $\eta(\sigma)$ is a topological invariant. It determines and is determined by the topology of the foliation $\mathcal{F}(\sigma)$.*

2. Proof of the pre-theorem.

In suitable coordinates, (1) (2) is expressed by:

$$dz_j = \lambda_j z_j dT_j, \quad z_j = e^{\lambda_j T_j} w_j = e^{\lambda_j (T_j + C_j)}, \quad j = 1, \dots, m. \quad (8)$$

For a given diagonal σ , and analogously for σ' , recall that $\hat{\lambda}_j = 2\pi i \lambda_j^{-1}$. We assume first $\hat{\lambda}'_j = g \hat{\lambda}_j$, $j = 1, \dots, m$, $g \in \text{GL}^+(2, \mathbf{R})$. The *homeomorphism*:

$$h : (\mathbf{C}^m, \mathcal{F}(\sigma)) \rightarrow (\mathbf{C}^m, \mathcal{F}(\sigma'))$$

required for the pre-theorem is then defined as follows:

If $z_j(z) = e^{\lambda_j T_j}$ respectively \mathfrak{o} ,

then $z_j(h(z)) = e^{\lambda'_j T'_j}$ respectively \mathfrak{o} , where $T'_j = g T_j$.

This is well defined because T_j is determined modulo $\hat{\lambda}_j$ and T'_j modulo $\hat{\lambda}'_j$. Moreover the image of an (any) $\mathcal{F}(\sigma)$ -leaf (8) is the set:

$$e^{\lambda'_j (g T_j + C_j)} = e^{\lambda'_j T'_j} w'_j,$$

and this is an $\mathcal{F}(\sigma')$ -leaf.

The non-oriented elements ⁽²⁾ g of $\text{GL}(2, \mathbf{R})$ are realized by composing with one of them *e.g.* complex conjugation of $\mathbf{C} = \mathbf{R}^2$. It sends $(\lambda_1, \dots, \lambda_m)$ into $(\bar{\lambda}_1, \dots, \bar{\lambda}_m)$. The required homeomorphism of \mathbf{C}^m is given by complex conjugation:

$$h : (z_1, \dots, z_m) \mapsto (\bar{z}_1, \dots, \bar{z}_m).$$

Remark. — If $z_j(z) = e^{u + iv}$, then $z_j(h(z)) = e^{\alpha_j u + i(\beta_j u + v)}$ for some real constants α_j , β_j and the mapping h :

$$\begin{cases} |z_j(h(z))| = |z_j(z)|^{\alpha_j} \\ \arg z_j(h(z)) = \arg z_j(z) + \beta_j \ln |z_j(z)| \end{cases} \quad (9)$$

⁽¹⁾ (Replacing λ_j by $\lambda_j/|\lambda_j|$, we easily see that the Siegel domain is connected for $m = 3$ and 4 , and it has three components for $m = 5$). A more complicated definition of Siegel domain is customary in the theory of holomorphic equivalence.

⁽²⁾ J.-P. Francoise drew our attention to this case which we had overlooked.

produces in the j -th coordinate axis $\{z : z_k = 0 \text{ for } k \neq j\}$ a *spiraling homeomorphism* (9) for $z_j \rightarrow 0$ or ∞ , with the unit circle $|z_j| = 1$ pointwise fixed. It leaves invariant each of the manifolds $z_j = 0$ and $|z_j| = 1$, as well as the piecewise smooth $(2m-1)$ -sphere:

$$S = \{z : \sup_j |z_j| = 1\}. \quad (10)$$

Remark. — h preserves the additive group action of $\mathbf{C} = \mathbf{R}^2$ (see T in (8)).

3. The foliation on W, the union of the Siegel leaves, is stable.

We assume (7). The real function $\|z\|^2 = \sum_j z_j \bar{z}_j$ has a critical value on a leaf (8) at a point z if and only if:

$$\begin{aligned} 0 &= d \sum_j z_j \bar{z}_j = \sum_j (z_j \bar{\lambda}_j \bar{z}_j d\bar{T} + \bar{z}_j \lambda_j z_j dT) \\ &= \sum_j z_j \bar{z}_j (\lambda_j dT + \bar{\lambda}_j d\bar{T}) = 0 \quad \text{for } dT \in \mathbf{C} \end{aligned}$$

$$dT = 1 \quad \text{yields} \quad \sum_j z_j \bar{z}_j (\lambda_j + \bar{\lambda}_j) = 0$$

$$dT = i \quad \text{yields} \quad \sum_j z_j \bar{z}_j (\lambda_j - \bar{\lambda}_j) = 0.$$

The union M of the 0-nearest points, $z \neq 0$, has therefore the equation:

$$M : \sum_j z_j \bar{z}_j \lambda_j = 0, \quad z \neq 0. \quad (11)$$

No leaf has two (or more) critical points and every critical value is a minimum, because for any $T_1 \neq T_2$ the real function:

$$t \mapsto \sum_j |z_j|^2, \quad z_j = e^{\lambda_j(tT_1 + (1-t)T_2)} w_j, \quad j = 1, \dots, m,$$

is a *sum of real exponential functions* in $t \in \mathbf{R}$, hence concave. A leaf with a minimum is called a *Siegel leaf*. It is a closed embedding of \mathbf{C} and can be characterised by its critical point $\zeta = (\zeta_1, \dots, \zeta_m)$ in M. The union W of all Siegel leaves is therefore the total space of a trivial bundle, $W = M \times \mathbf{C} \rightarrow M$, embedded in \mathbf{C}^m by:

$$z_j = \zeta_j e^{\lambda_j T}, \quad j = 1, \dots, m; \quad (\zeta, T) \in M \times \mathbf{C}$$

with base space M.

M is seen to be a *manifold* by putting in (11):

$$z_j = x_j + iy_j, \quad \lambda_j = \mu_j + i\nu_j, \quad M : \sum_j (x_j^2 + y_j^2) \mu_j = \sum_j (x_j^2 + y_j^2) \nu_j = 0,$$

and by calculating the tangent space:

$$(dx_1, \dots, dy_m) : \sum_j (x_j dx_j + y_j dy_j) \mu_j = \sum_j (x_j dx_j + y_j dy_j) \nu_j = 0$$

with coefficient matrix of rank 2, because every determinant $\mu_j \nu_k - \mu_k \nu_j \neq 0$, for $j \neq k$ by (7). The manifold M is a *cone* with deleted top $0 \in \mathbf{C}^m$ over the compact manifold:

$$M(1) = \{z \in M : \|z\|^2 = \sum_j z_j \bar{z}_j = 1\}.$$

From (11), where $c_j = z_j \bar{z}_j \geq 0$, we see that $o \in \mathbf{C}$ is a weighted mean of the set of complex numbers $\Lambda = \{\lambda_1, \dots, \lambda_m\}$. Hence Siegel leaves can only exist (and M is not empty) in the Siegel domain case $o \in \mathcal{H}(\Lambda)$. In § 4 we will see that then:

$$W = \{z : o \in \mathcal{H}(\{\lambda_j : j \in J(z)\})\} \quad (12)$$

where: $J(z) = \{j : z_j(z) \neq 0\}$. (13)

It is *open dense* in \mathbf{C}^m .

The (abstract) *differentiable manifold* M depends by (11) continuously on Λ , and is therefore “*constant*” on each component of the Siegel domain. Then also the topology of the restriction of the foliation: $\mathcal{F}(\sigma)|_W$ is locally constant (= stable), and gives therefore no topological invariants.

4. Geometry in the T-plane of a leaf.

We assume (7), use coordinates as in (8) but ordered in such a way that:

$$0 \leq \arg \hat{\lambda}_1 < \arg \hat{\lambda}_2 \dots < \arg \hat{\lambda}_m < 2\pi. \quad (14)$$

The parameter T in the leaf of a point z is determined up to translations in $\mathbf{C} = \mathbf{R}^2$. The intersection of a leaf with the “ball” $B = \{z : \sup_j |z_j| \leq 1\}$ and with the manifolds $|z_j| = 1$, gives rise to interesting configurations in the T -plane of that leaf. We introduce the *configuration* $G = G(z)$ consisting of the half-planes (see (8) and fig. 1):

$$\alpha_j = \{T : |z_j| \leq 1\} \subset \mathbf{C}, \quad j \in J(z) = \{j : z_j \neq 0\}.$$

The boundary $\partial\alpha_j$ is a line parallel to and oriented by the vector $\hat{\lambda}_j$. We also define the convex disc:

$$D(z) = \bigcap_j \alpha_j \subset \mathbf{C}, \quad (15)$$

which represents the *intersection of the leaf with B, and its boundary, the oriented convex polygon* $C = C(z)$. Let $I(z) \subset J(z)$ be the set of indices j involving edges $\partial\alpha_j$ of $C(z)$. Let the edge on $\partial\alpha_j$ be between vertices T_{j-} and T_j where j is the cyclic successor of j_- in $I(z)$. For later use we define $\tilde{n}_j \in \mathbf{R}$ by:

$$T_j = T_{j-} + \tilde{n}_j \hat{\lambda}_j \quad (16)$$

$2\pi\tilde{n}_j$ is the increase of the argument of z_j from T_{j-} to T_j . The real number \tilde{n}_j differs from the integral number of those points on the edge $T_{j-}T_j$ where z_j is real by at most one.

If the polygon C is bounded and if we set $\tilde{n}_j = 0$ for $j \notin I(z)$, then clearly (see (16) or fig. 1):

$$\sum_j \tilde{n}_j \hat{\lambda}_j = 0. \quad (17)$$

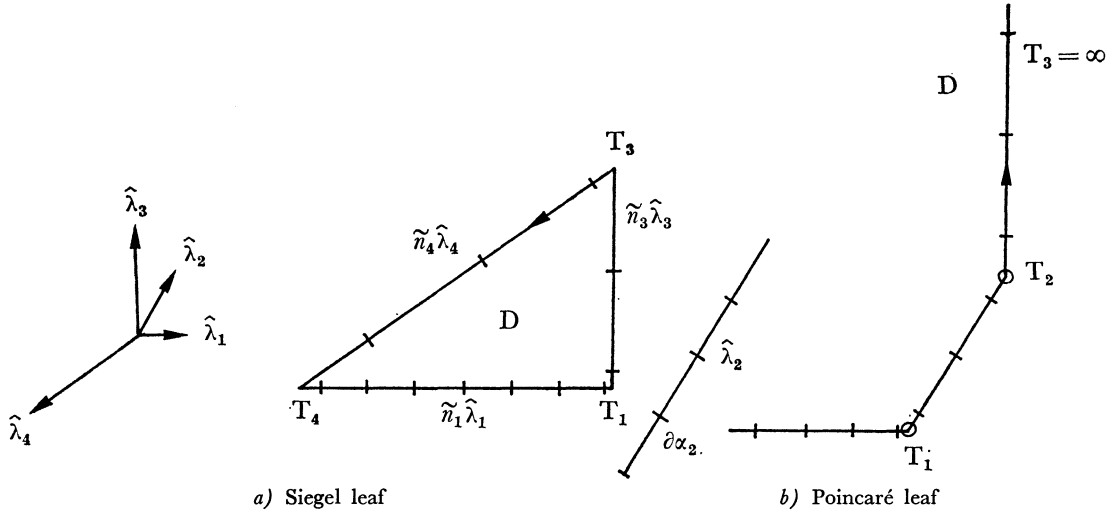

FIG. 1

The complete configuration $G^*(z)$ of the leaf of z consists of the set $G(z)$ of half planes α_j numbered by $j \in J(z)$ with oriented boundaries $\partial\alpha_j$, together with the set of those points (marked in fig. 1) on $\partial\alpha_j$ where z_j is real. $G^*(z)$ is to be considered modulo translations of $\mathbf{C} = \mathbf{R}^2$. The point $o \in \mathbf{C}^m$ is represented by the empty configuration.

Lemma 1. — Every complete configuration that agrees with $\hat{\Lambda} = (\hat{\lambda}_1, \dots, \hat{\lambda}_m)$ determines a unique leaf. A point $T \in \mathbf{C}$ determines a unique point z in that leaf.

Proof. — If the half-plane α_j is not in $G(z)$, then $z_j(z) = 0$ on the leaf. If z_j is known at some point of the leaf (and z_j is known to be 1 at the marked points of $\partial\alpha_j$!) then the formulas (8) determine z_j at every other point T and for example at $T(z)$. So then $z = z(T)$ and its leaf are determined.

Remark. — By letting $g \in GL(2, \mathbf{R})$ with $g\hat{\Lambda} = \hat{\Lambda}'$ act on the T -plane $\mathbf{C} = \mathbf{R}^2$ and on all complete configurations with respect to $\hat{\Lambda}$ in \mathbf{R}^2 , we obtain the homeomorphism h of § 2.

Lemma 2. — Assuming (7), every leaf of $\mathcal{F}(\sigma)$ outside $o \in \mathbf{C}^m$, is of one of the following kinds:

- A coordinate axis, topologically a cylinder, in case the polygon $C(z)$ is one line. There are m axes.
- A Siegel leaf (see (13)), a closed embedding of \mathbf{C} in \mathbf{C}^m , with bounded or empty polygon $C(z)$, in case $o \in \mathcal{H}(\{\hat{\lambda}_j : j \in J(z)\})$.
- A Poincaré leaf, an embedding of \mathbf{C} in \mathbf{C}^m , transversal to each “sphere” $\sup_j |z_j| = r > 0$, with unbounded polygon $C(z)$, in case $o \notin \mathcal{H}(\{\hat{\lambda}_j : j \in J(z)\})$.

Proof. — First suppose $z_j \neq 0$ for all j , $o \notin \mathcal{H}(\{\hat{\lambda}_1, \dots, \hat{\lambda}_m\})$, $m \geq 2$. We then may assume:

$$0 \leq \arg \hat{\lambda}_1 < \arg \hat{\lambda}_2 < \dots < \arg \hat{\lambda}_m < \pi \quad (18)$$

and the half planes α_j clearly have an unbounded intersection. Along any real vector $\mu \in \mathbf{C} = \mathbf{R}^2$ for which:

$$\arg \hat{\lambda}_m < \arg \mu < \pi$$

attached at any point in the T-plane, the *linear function on \mathbf{R}^2* , $\ln |z_j|$, decreases for $j=1, 2, \dots, m$. Then the leaf is transversal to every "sphere" $\sup |z_j| = r > 0$. Topologically, the leaf is a cone over its intersection $\mathbf{C}(z)$ (homeomorphic to \mathbf{R}) with $\mathbf{S} = \{z : \sup |z_j| = 1\}$. For $w \in \mathbf{R} = \mathbf{C}(z)$ (see fig. 1 b) converging to $-\infty$ (resp. ∞) the first (resp. last) coordinate converges in absolute value to 1, and all others to zero. The point $w \in \mathbf{C}(z)$ converges to the unit circle in the first (resp. last) axis. The leaf is called a *Poincaré leaf*.

The same argument applies to any z for which $0 \notin \mathcal{H}(\{\hat{\lambda}_j : j \in \mathbf{J}(z)\})$ in case $\mathbf{J}(z)$ contains at least two indices. We then restrict the argument to the coordinates z_j for which $j \in \mathbf{J}(z)$.

There remains the case where $0 \in \mathcal{H}(\{\hat{\lambda}_j : j \in \mathbf{J}(z)\})$. Then $\mathbf{C}(z)$ is either a bounded polygon or empty. In both cases $\{\mathbf{T} : \sup_j |z_j| \leq \mathbf{N}\}$ is for large $\mathbf{N} > 0$ a compact convex set on the T-plane and $\|z\|$ has a minimum in the interior. So the leaf is a *Siegel leaf* by the definition in § 3.

As announced in (12) we have:

$$\mathbf{W} = \{z \in \mathbf{C}^m : 0 \in \mathcal{H}(\{\hat{\lambda}_j : j \in \mathbf{J}(z)\})\}.$$

An immediate corollary of lemma 1 is (see fig. 1):

Lemma 3. — The leaf of z , given Λ , is completely determined by the following "coordinates":

- 1) $\mathbf{J}(z)$, $\mathbf{I}(z)$ and \tilde{n}_j for $j \in \mathbf{I}(z)$.
- 2) The maximum $e^{-\beta_s} \leq 1$ of $|z_s(\mathbf{T})|$ for $\mathbf{T} \in \mathbf{C}(z)$, $s \in \mathbf{J}(z) \setminus \mathbf{I}(z)$. This equals $|z_s(\mathbf{T}_j)|$ for $j_- < s < j$ in cyclic order $j_-, j \in \mathbf{I}(z)$.
- 3) The argument $\varphi_s = \arg z_s$, at the vertex $\mathbf{T}_j \in \mathbf{C}$, for $j_- < s \leq j$.

In the case of a Siegel leaf, $0 \in \mathcal{H}(\{\hat{\lambda}_j : j \in \mathbf{J}\})$, all these, $\mathbf{I} \subset \mathbf{J}$, \tilde{n}_j , β_s , $\varphi_s \bmod 2\pi$, can be chosen arbitrarily, but for the condition:

$$\sum_j \tilde{n}_j \hat{\lambda}_j = 0.$$

5. The topological invariant $\eta(\sigma) = \Delta$ in the Siegel domain case.

We prove theorem 1, knowing the pre-theorem, by giving a *topological description of the $(m-3)$ -dimensional convex polytope*:

$$\Delta = \{(c_1, \dots, c_m) : c_j \geq 0 \forall j, \sum_j c_j = 1, \sum_j c_j \hat{\lambda}_j = 0\} \subset \mathbf{R}^m. \quad (19)$$

A sequence of weights c_1, \dots, c_m in (19) which makes 0 the barycenter of $\hat{\Lambda}$ is invariant under the action of $\text{GL}(2, \mathbf{R})$ on $\hat{\Lambda}$. Vice versa Δ determines $\hat{\Lambda}$ modulo that action.

To see this take $\hat{\lambda}'_1 = 1$, $\hat{\lambda}'_2 = i$, and determine $\hat{\lambda}'_j$ by taking $c_k = 0$ for $k \neq 1, 2$ or j in (19). Hence Δ is equivalent to $\eta(\sigma)$.

Let S_j be a small section transversal to the foliation $\mathcal{F}(\sigma)$ at a point p_j on the j -th axis and $n_j = n_j(L)$ the number of intersection points with some Siegel leaf L . We now define Δ' as the closure in \mathbf{R}^m of the set of m -tuples (c_1, \dots, c_m) of positive numbers, for which there exists a sequence of Siegel leaves L_α ($\alpha = 1, 2, \dots$) such that for $\alpha \rightarrow \infty$:

$$n_j \rightarrow \infty \quad \text{and} \quad \lim_{\alpha \rightarrow \infty} \frac{n_j}{\sum_k n_k} = c_j \quad \text{for all } j \quad (20)$$

The definition of Δ' is purely topological. We prove that for every choice of S_j , p_j :

Lemma 4. — $\Delta' = \Delta$.

Proof. — Under holonomic transport of S_j with respect to the foliation, the intersection numbers with any leaf remain constant. After such transport along a curve in the j -th axis from p_j to the point with coordinates $z_j = 1$, $z_k = 0$ for $k \neq j$, we may assume for some $0 < \delta < 1$:

$$S_j(\delta) \subset S_j \subset S_j(1) \subset S = \{z : \sup_k |z_k| = 1\}$$

where: $S_j(\delta) = \{z : z_j = 1, |z_k| < \delta \leq 1 \text{ for } k \neq j\}$. (21)

The Siegel leaf of z meets $S_j(\delta)$ and S_j inside S , hence in the convex polygon $C(z)$ in the T -plane and in marked points of $\partial\alpha_j$. Because the real functions $\ln |z_k| = \operatorname{Re} \lambda_k(T + c_k)$ on the T -plane \mathbf{R}^2 with level lines parallel to $\hat{\lambda}_k$, have constant gradients, no two of which are \mathbf{R} -linearly dependent by (7), there exists for any $\delta > 0$ a number $K > 0$ such that:

$$|\ln |z_k(T + t\hat{\lambda}_j)| - \ln |z_k(T)|| > |\ln \delta|$$

for $t > K$, for all k and $j \neq k$. In particular in the edge $T_{j-}T_j$ (see fig. 2) of the polygon $C(z)$ (on which $|z_k| \leq 1$ for all k) we see that S_j and

$$S_j(\delta) : |z_j| = 1, |z_k(T)| < \delta < 1 \text{ for } k \neq j \quad (22)$$

contain all points:

$$T = T_{j-} + t\hat{\lambda}_j, \quad K < t < \tilde{n}_j - K. \quad (22')$$

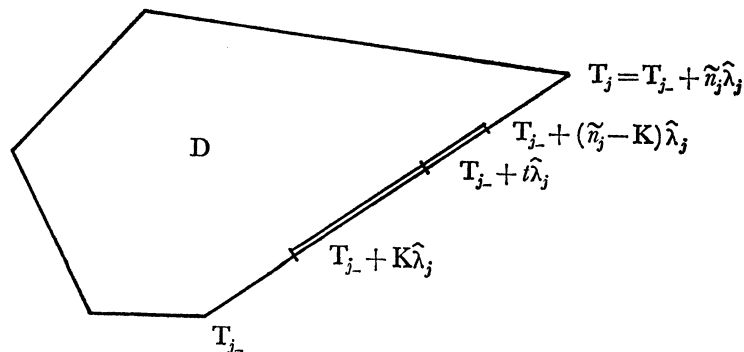

FIG. 2

Counting intersection points (marked on $\partial\alpha_j$) of a Siegel leaf L_α we see from (21):

$$n_j(S_j(\delta)) \leq n_j(S_j) = n_j \leq n_j(S_j(1)) \leq \tilde{n}_j + 1.$$

From (22) we read that all marked points on the interval (22') belong to $S_j(\delta)$. There remain at most $2(K+1)$ other marked points between T_{j-} and T so that:

$$\tilde{n}_j - n_j(S_j(\delta)) \leq 2K + 3.$$

Hence for all Siegel leaves:

$$|\tilde{n}_j - n_j| \leq 2K + 3. \quad (23)$$

But by (17) $\sum_j \tilde{n}_j \hat{\lambda}_j = 0$.

Then:
$$\sum_j \frac{\tilde{n}_j}{\sum_k \tilde{n}_k} \hat{\lambda}_j = 0.$$

From (20) and (23) we obtain:

$$\sum_j c_j \hat{\lambda}_j = 0.$$

We have proved $\Delta' \subset \Delta$. If we take any (c_1, \dots, c_n) in Δ with $c_j > 0$ for all j , then there is by lemmas 1 and 3 a Siegel leaf L_α with:

$$\tilde{n}_j = \alpha c_j, \quad j = 1, \dots, m.$$

For $\alpha = 1, 2, 3, \dots, \alpha \rightarrow \infty$ we have:

$$\tilde{n}_j / \sum_k \tilde{n}_k = c_j, \quad \text{hence} \quad \lim_{\alpha \rightarrow \infty} n_j / \sum_k n_k = c_j$$

by (23). Consequently $\Delta' = \Delta$ and theorem I is proved.

6. An explicit homeomorphism in the case of the Poincaré domain.

Here we assume (7), (8), $0 \notin \mathcal{H}(\hat{\Lambda})$:

$$0 \leq \arg \hat{\lambda}_1 < \arg \hat{\lambda}_2 < \dots < \arg \hat{\lambda}_m < \arg \mu < \pi. \quad (24)$$

Every leaf that is not an axis is a Poincaré leaf, meeting S in a curve that is represented in the T -plane by an unbounded convex polygon C . It has at least one vertex and is transversal to the constant vector field μ . The T -plane of a leaf is then naturally a product:

$$T = T_0 + s\mu, \quad T_0 \in C, \quad s \in \mathbf{R}.$$

Taking all these products together we write $\mathcal{F}(\sigma)$ as the product of a 1-foliation $\mathcal{F}_1(\sigma) = \mathcal{F}(\sigma) \cap S$ and \mathbf{R} , by the formulas for $0 \neq w \in \mathbf{C}^m$, $z \in S$, $s \in \mathbf{R}$:

$$w_j = e^{\lambda_j s \mu} z_j, \quad j = 1, \dots, m. \quad (25)$$

Let σ' fulfil the same conditions as σ . In order to define a homeomorphism:

$$h : \mathcal{F}(\sigma) \rightarrow \mathcal{F}(\sigma')$$

it suffices by the last remark and (25) to define the restriction:

$$h_1 = h|_S : \mathcal{F}_1(\sigma) \rightarrow \mathcal{F}_1(\sigma')$$

of h to S . The map h_1 will induce a map h_L from the set of leaves of $\mathcal{F}_1(\sigma)$ onto the set of leaves of $\mathcal{F}_1(\sigma')$. We begin with the definition of h_L . Recall lemma 1, § 4 saying that for given Λ the leaves (except axes) are 1-1-represented by complete configurations G^* modulo translation. We define h_L by claiming that it is expressed by the identity in terms of the "coordinates" of lemma 3, § 4. This does not work for the m axes. We let h_L map each axis onto itself. We now examine this definition of h_L in detail.

Equality of the first sets of "coordinates" in lemma 3 has the following consequences: $J' = J$ gives the invariance of (the union of all leaves in) $z_j = 0$ for $j = 1, \dots, m$.

If C and C' are convex polygons corresponding with a leaf γ and its image leaf $h_L(\gamma)$, then $I' = I$ implies that the same coordinates among z_1, \dots, z_m take absolute value *one* on edges of C and of C' . This determines a correspondence of edges.

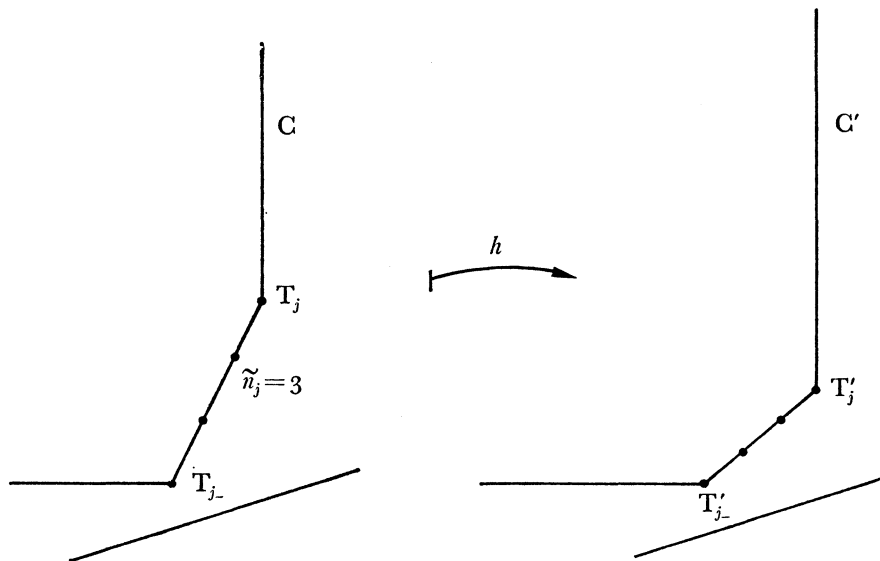

FIG. 3

$\tilde{n}'_j = \tilde{n}_j$ for $j \in I = I'$ determines, for given Λ, Λ' , the lengths of the bounded edges of C' of the leaf $h_L(\gamma)$ once those of C of the leaf γ are given. Therefore we now have obtained a one-one-correspondence between polygons C and C' modulo translations, which correspondence must lift to h_L .

With equality of the second sets of "coordinates" in lemma 3, we obtain the necessary information on the absolute values of those coordinates z_j , $j \in J$, for which $j \notin I$, at certain vertices of C and C' :

$$e^{-\beta_j} = |z_s(T'_{j-})| = e^{-\beta_s} = |z_s(T_{j-})|$$

for $j_- < s < j$, and j the successor of j_- in I .

With equality of the third sets of “coordinates” in lemma 3, we *complete the definition of h_L* because we obtain the necessary information on the arguments of the coordinates z_j of certain vertices of C and C' :

$$\varphi'_s = \arg z_s(T'_j) = \varphi_s = \arg z_s(T_j)$$

for $j_- \leq s \leq j$, j successor of j_- .

On one hand $z_s(T_j)$ is not defined if $T_j = \infty \in \mathbf{C} \cup \infty$ but no ambiguities arise in case neither T_{j_-} nor T_j is ∞ , because $\tilde{n}'_j = \tilde{n}_j$ implies:

$$\varphi'_j(T'_{j_-}) = \varphi_j(T_{j_-}) \Leftrightarrow \varphi'_j(T'_j) = \varphi_j(T_j).$$

Having obtained the map h_L we now define a point set bijection $h_1 : S \rightarrow S$, which is a lift of h_L , by assigning to the point $T = T_{j_-} + t\hat{\lambda}_j$ on the polygon C of a leaf γ of $\mathcal{F}_1(\sigma)$ the point $T' = T'_{j_-} + t\hat{\lambda}'_j$ on the polygon C' of the leaf $h_L(\gamma)$ of $\mathcal{F}_1(\sigma')$, and similarly in case $T_{j_-} = \infty$ with $T = T_j - t\hat{\lambda}_j$. In particular vertices of C go to vertices of C' . We define h_1 to be the identity map on each axis. It remains to prove that h_1 is continuous. Then also h_1^{-1} is continuous by interchange of $\mathcal{F}(\sigma)$ and $\mathcal{F}(\sigma')$.

Proof. — For a given Λ , the set of all leaves with a fixed set of nonzero coordinates J is homeomorphically represented by the set of all its complete configurations (lemma 1) in its natural topology. This space is also seen to be homeomorphically represented (embedded) by the following sets of “coordinates” of lemma 3:

$$\begin{aligned} e^{\tilde{n}'_s} z_s(T_j) &= e^{\tilde{n}'_s - \beta_s + i\varphi_s} & j_- < s \leq j & \text{ for } T_j \neq \infty \neq T_{j_-} \\ &= z_j(T_{j_-}) & \text{ for } T_j = \infty \\ &= z_j(T_j) & \text{ for } T_{j_-} = \infty; \end{aligned} \quad (26)$$

j is the successor of j_- in I .

Recall that $T_j \neq \infty$ is a point in the polygon (I -leaf) C , at which $|z_s|$ takes its maximal value ≤ 1 . If this value is smaller than one, then \tilde{n}'_s is automatically zero.

As h is the identity in these “coordinates” we conclude that *the restriction of h to $\{z : J = \{j : z_j \neq 0\}\} \cap S$* induces a homeomorphism of the space of those I -leaves in S , and then h_1 is a homeomorphism of that part of S onto itself as well.

The formulas (26) tell even more, because we can include the values $z_s = 0$ in the consideration and let s run through all indices between the first, j_b , and the last, j_e , of J . Therefore we can conclude that h_1 is a homeomorphism onto itself on each of the sets:

$$\Omega(j_b, j_e) = \{z : z_{j_b} \neq 0, z_{j_e} \neq 0, z_j = 0 \text{ for } j < j_b < j_e \text{ and } z_j = 0 \text{ for } j > j_e\} \cap S,$$

and in particular on the open dense set:

$$\Omega(I, m) = \{z : z_1 \neq 0, z_m \neq 0\} \cap S \subset S.$$

We next prove that h is also continuous at any point $w \notin \Omega(j_b, j_e)$, w not on an axis:

$$\begin{aligned} w = (w_I; w_{II}; w_{III}) &= (0; w_{II}; 0) = (0, \dots, 0; w_{j_b}, \dots, w_{j_e}; 0, \dots, 0) \\ &w_{j_b} \neq 0, \quad w_{j_e} \neq 0, \quad j_b < j_e. \end{aligned}$$

By the above consideration h is continuous at and near w , on the subspace defined by $z_I=0$ and $z_{III}=0$. So we can restrict our study of continuity to points:

$$z = (z_I; z_{II}; z_{III}) \quad \text{with} \quad z_{II} = w_{II}.$$

The point $w \in S$ is represented by some point $T(w)$ on the configuration $G(w)$. The configuration $G(z)$, in the T -plane of the leaf of z , is then obtained from $G(w)$ by adding half-planes α_j for the coordinates in z_I ($z_j : j < j_b$) and half-planes for the coordinates in z_{III} ($z_j : j > j_e$). Let $\|z-w\| = \delta$. If δ is small then all the new boundaries $\partial\alpha_j$ will meet $C(w)$ far away from its vertices and from $T(w)$ on either of the two unbounded edges (fig. 3). Then the point w and the point z are represented by the same point of $C(w)$. (See the equations for a leaf.) The 1-1-correspondence h_1 preserves this property of far-ness concerning the images $G'(h_1(w))$ and $G'(h_1(z))$. Moreover *vice versa* far-ness of the new half-plane boundaries $\partial\alpha'_j$ implies that $|z_j|$ is small for $j < j_b$ and $j > j_e$. Therefore continuity follows:

$$\|h(z) - h(w)\| = O(\delta).$$

By the equations (26), we find for any point $z \in S$ not on the j -th axis, but so that $|z_j(z)| = 1$:

$$z_j(h(z)) = z_j(z).$$

This identity relation is also the definition of h on the j -th axis. With a "far-away" argument concerning other coordinates, this proves continuity also at axis-points in S .

7. A corollary on stability admitting non linear perturbations as well.

Corollary 1. — Let F be a holomorphic vector field in \mathbf{C}^m , $F(0) = 0$, and let $\sigma = DF_0$ have the spectrum $\{\lambda_1, \dots, \lambda_m\}$. Then F is locally stable (of codimension zero) near $0 \in \mathbf{C}^m$ if and only if $i \neq j \Rightarrow \lambda_i \notin \mathbf{R}\lambda_j$, and $0 \notin \mathcal{H}(\lambda_1, \dots, \lambda_m)$.

Proof. — If $0 \in \mathcal{H}(\lambda_1, \dots, \lambda_m)$, then we can approximate F , by Siegel's theorem ([13], [12]), by another vector field \tilde{F} , $\tilde{F}(0) = 0$, which is holomorphically equivalent to its linear part $\tilde{\sigma} = D\tilde{F}_0$, and whose spectrum $\tilde{\sigma}$ is in the Siegel domain. By theorem I $\tilde{\sigma}$ is not stable, so F is not stable. On the other hand, if $i \neq j \Rightarrow \lambda_i \notin \mathbf{R}\lambda_j$ and $0 \notin \mathcal{H}(\lambda_1, \dots, \lambda_m)$, Guckenheimer [2] proved that $\mathcal{F}(\sigma)$ meets every sphere

$$S_r : \|z\|^2 = \sum_{j=1}^m z_j \bar{z}_j = r^2 > 0$$

transversally, hence in a real 1-foliation, and that the leaves are the orbits of a Morse-Smale vector field with m closed orbits. From the structural stability of these vector fields [10] follows the local stability of F , also under small non-linear perturbations. So it remains to show that whenever $0 \notin \mathcal{H}(\lambda_1, \dots, \lambda_m)$ and two eigenvalues are dependent over \mathbf{R} then F is not stable. Suppose $\lambda_2 \in \mathbf{R}\lambda_1$, $0 \notin \mathcal{H}(\lambda_1, \dots, \lambda_m)$. Arbitrarily near to F we find F' with $\{\lambda'_1, \dots, \lambda'_m\}$ in the Poincaré domain: $0 \notin \mathcal{H}(\lambda'_1, \dots, \lambda'_m)$,

$i \neq j \Rightarrow \lambda'_i \notin \mathbf{R}\lambda'_j$, and moreover obeying the conditions $\lambda'_j - \sum_{i=1}^m k_i \lambda'_i \neq 0$ for any non-negative integers k_1, \dots, k_m . By Poincaré [I I] F' is locally holomorphically equivalent to its linear part. It has Poincaré leaves only except for the cylindrical coordinate axes. Arbitrarily near to F we also find F'' with $\{\lambda''_1, \dots, \lambda''_m\}$ obeying the following conditions: $0 \in \mathcal{H}(\lambda''_1, \dots, \lambda''_m)$, $\lambda''_2 = r\lambda''_1$, r rational, $\lambda''_i \notin \mathbf{R}\lambda''_j$ for $i \neq j$, $i \geq 2$, $j \geq 2$, and:

$$\lambda''_j - \sum_{i=1}^m k_i \lambda''_i \neq 0$$

for any non-negative integers k_1, \dots, k_m . By Poincaré [I I] F'' is locally holomorphically equivalent to its linear part σ'' . But all leaves of σ'' in the linear subspace with equations $z_3 = z_4 = \dots = z_m = 0$ are cylinders, so $\mathcal{F}(F')$ and $\mathcal{F}(F'')$ are not homeomorphic near zero, and F is not stable.

II. — HOLOMORPHIC FLOWS ON $\mathbf{CP}(m)$

8. Holomorphic flows on $\mathbf{CP}(m)$ arise from linear vector fields on \mathbf{C}^{m+1} .

Here we prove the (known)

Lemma. — Every holomorphic vector field over $P = \mathbf{CP}(m)$ originates naturally from a linear vector field on \mathbf{C}^{m+1} ($\sigma z \in \mathbf{C}^{m+1}$, $\sigma \in \mathbf{GL}(m+1, \mathbf{C})$).

Proof. — Consider the embedding of the trivial one dimensional vector bundle over $\mathbf{C}_*^{m+1} = \mathbf{C}^{m+1} - \{0\}$ into the (trivial) tangent bundle, given by the following inclusion of total spaces:

$$\{(z, \mu z) : z \in \mathbf{C}_*^{m+1}, \mu \in \mathbf{C}\} \subset \mathbf{C}_*^{m+1} \times \mathbf{C}^{m+1}.$$

The first bundle has the section $\mu = 1$. This section, as well as the embedding, is invariant under the action of $\mathbf{C}^* = \mathbf{C} - \{0\}$:

$$\lambda.(z, w) = (\lambda z, \lambda w), \quad \lambda \in \mathbf{C}^*.$$

The quotient is an embedding of vector bundles over P that can be completed in an exact sequence with the tangent bundle τ of P :

$$0 \rightarrow \theta \rightarrow \eta \rightarrow \tau \rightarrow 0.$$

θ is trivial with non zero section ($\mu = 1$). Čech cohomology of P with coefficients in the sheaves of germs of sections of these bundles, gives rise to a long exact sequence that begins with groups of global cross sections $H_0 = \Gamma$:

$$0 \rightarrow \Gamma(P, \theta) = \mathbf{C} \rightarrow \Gamma(P, \eta) (= \mathbf{C}^{(m+1)*}, \text{ see below})$$

$$\xrightarrow{\iota} \Gamma(P, \tau) \rightarrow H_1(P, \text{sheaf } \theta) = H_{0,1}(P, \mathbf{C}) = 0.$$

Hence ι is surjective onto the set of holomorphic vector fields $\Gamma(\mathbf{P}, \tau)$. Each holomorphic section of $\Gamma(\mathbf{P}, \eta)$ lifts to a holomorphic vector field $F(z)$ on \mathbf{C}_*^{m+1} that is invariant under the action of \mathbf{C}^* :

$$\lambda F(z_0, \dots, z_m) = F(\lambda z_0, \dots, \lambda z_m).$$

Differentiation with respect to z_j yields

$$\lambda \partial_j F(z_0, \dots, z_m) = \partial_j F(\lambda z_0, \dots, \lambda z_m) \cdot \lambda.$$

The holomorphic vector field

$$\partial_j F(\lambda z_0, \dots, \lambda z_m) = \partial_j F(z_0, \dots, z_m)$$

is bounded near $o \in \mathbf{C}^{m+1}$, hence it extends over zero, with value $o \in \mathbf{C}^{m+1}$. Then:

$$\partial_j F(z_0, \dots, z_m) = \partial_j F(o, \dots, o) = \text{constant}.$$

$F(z)$ is linear and the lemma is proved.

9. The topological invariants.

Let \mathcal{F} be the flow of a holomorphic vector field on the projective space $\mathbf{CP}(m)$, which comes from the linear vector field on \mathbf{C}^{m+1} :

$$\frac{dz}{dT} = \sigma z, \quad z = e^{\sigma T} w, \quad z, w \in \mathbf{C}^{m+1}, \quad T \in \mathbf{C}. \quad (27)$$

As before $z = (z_0, \dots, z_m)$ is a set of homogeneous coordinates for

$$\mathbf{CP}(m) = (\mathbf{C}^{m+1} - \{o\}) / \mathbf{C}^*.$$

The spectrum $\Lambda = \{\lambda_0, \dots, \lambda_m\}$ of σ is a projective invariant of the flow, but should now be considered modulo the group of all translations and similarities in \mathbf{C} . (If we replace T by $\omega^{-1}T$, then $\Lambda \subset \mathbf{C}$ is multiplied by $\omega \in \mathbf{C}^*$, and if we replace $e^{\sigma T} w$ by $e^{\sigma T - \lambda T} w$, $\lambda \in \mathbf{C}$, this translates λ_j to $\lambda_j - \lambda$ for $j=0, \dots, m$.) If σ is diagonalisable we have in preferred coordinates the flow $\mathcal{F}(\Lambda)$:

$$\frac{dz_j}{dt} = \lambda_j z_j, \quad z_j = e^{\lambda_j t} w_j, \quad j=0, \dots, m. \quad (28)$$

It has a singularity at each of the vertices of the coordinate simplex. Outside the coordinate hyperplane $z_k = 0$, we take $z_k = 1$ and non-homogeneous coordinates $z_j/z_k = z_j$ and we obtain the linear flow on \mathbf{C}^m :

$$\mathcal{F}_k = \mathcal{F}_k(\Lambda) : z_k = 1, \quad z_j = e^{(\lambda_j - \lambda_k)t} w_j \quad j \neq k. \quad (29)$$

In order to have $\lambda_i - \lambda_k$ and $\lambda_j - \lambda_k$ real independent for every $i \neq j \neq k \neq i$ (condition (7)), we make the

Assumption. — For $\lambda_i, \lambda_j, \lambda_k \in \Lambda$, $i \neq j \neq k \neq i$, $\lambda_i, \lambda_j, \lambda_k$ are not collinear in the plane \mathbf{C} . (30)

By theorem 1, \mathcal{F}_k has only the non-trivial topological invariant $\eta(\sigma) = \Delta$ in case the spectrum $\Lambda_k = \{(\lambda_j - \lambda_k), j \neq k\}$ is in the Siegel domain, that is in case λ_k is in the interior of $\mathcal{H}(\Lambda)$, and no topological invariant otherwise. We now formulate:

Theorem II. — *A complete set of topological invariants of a holomorphic flow $\mathcal{F}(\Lambda)$ (27) on $\mathbf{CP}(m)$, under the general position assumption (30), consists of the topological invariants of chapter I at the $m + 1$ singular points. In other words:*

- A) *If the boundary $\partial\mathcal{H}(\Lambda)$ of the convex hull $\mathcal{H}(\Lambda)$ is an $(m + 1)$ -gon, then there are no topological invariants: \mathcal{F} is stable.*
 B) *If $\partial\mathcal{H}(\Lambda)$ is an m -gon with one eigenvalue, say λ_k , in the interior, then*

$$\{2\pi i(\lambda_j - \lambda_k)^{-1}, j \neq k\} \subset \mathbf{C}$$

modulo action of $\mathbf{GL}(2, \mathbf{R})$, is the only topological invariant.

- C) *If $\mathcal{H}(\Lambda)$ has at least two eigenvalues in its interior, then Λ , modulo translations, similarities and reflections in $\mathbf{C} = \mathbf{R}^2$, is a topological invariant. It is the only one because it clearly is the complete invariant of \mathcal{F} under projective transformations and complex conjugation of $\mathbf{CP}(m)$.*

We first prove case C by determining the topological invariant. In § 10 we prove case A. We shall not elaborate on the proof of case B which goes along the same line as case A. For $m = 2$ cases B and C do not occur, and case A was proved in [16].

For case C we assume (30) for Λ and Λ' . Let $h: \mathcal{F}(\Lambda) \rightarrow \mathcal{F}(\Lambda')$ be a homeomorphism of $\mathbf{CP}(m)$ onto itself sending leaves of $\mathcal{F}(\Lambda)$ onto leaves of $\mathcal{F}(\Lambda')$. It sends any singular point onto a singular point with the same local topological invariants. We may assume after projective transformation of $\mathcal{F}(\Lambda')$ in $\mathbf{CP}(m)$ that each of the $m + 1$ singular points is invariant under h .

Let λ_0 and λ_1 be interior points of $\mathcal{H}(\Lambda)$. The corresponding singular points are then of Siegel type for $\mathcal{F}(\Lambda)$ and the same holds for their images under h which are singular points for $\mathcal{F}(\Lambda')$. Then λ'_0 and λ'_1 are also interior points of $\mathcal{H}(\Lambda')$. We can assume $\lambda_0 = \lambda'_0 = 0$ and $\lambda_1 = \lambda'_1 = 1$ by permitted changes of coordinates and parameters (translations and similarities).

By theorem 1, there exists $g_k \in \mathbf{GL}(2, \mathbf{R})$, $k = 0, 1$, such that for all j :

$$g_k(2\pi i(\lambda_j - \lambda_k)^{-1}) = 2\pi i(\lambda'_j - \lambda'_k)^{-1}.$$

Hence if $x_k, y_k \in \mathbf{R}$, are such that:

$$(k = 0) \quad 2\pi i\lambda_3^{-1} = x_0 2\pi i\lambda_2^{-1} + y_0 2\pi i$$

and: $(k = 1) \quad 2\pi i(\lambda_3 - 1)^{-1} = x_1 2\pi i(\lambda_2 - 1)^{-1} + y_1 2\pi i(0 - 1)^{-1}$,

then the same equations hold for λ'_2 and λ'_3 . Elimination of λ_3 yields (for given x_0, y_0, x_1, y_1):

$$\lambda_3 = \frac{\lambda_2}{x_0 + y_0 \lambda_2} = 1 + \frac{\lambda_2 - 1}{x_1 + y_1(\lambda_2 - 1)}$$

which is a quadratic equation in λ_2 with real coefficients. If one solution is λ_2 , then another is $\lambda'_2 = \lambda_2$ or $\bar{\lambda}_2$ and it follows that g_1 is either the identity ($\lambda'_2 = \lambda_2$) or the reflection: complex conjugation ($\lambda'_2 = \bar{\lambda}_2$). The topology of $\mathcal{F}(\Lambda')$ is therefore determined by $\Lambda = \Lambda'$ modulo translations, similarities and reflections, and case C is proved. Observe that the foliation of $\Lambda' = \bar{\Lambda}$ is obtained from that of Λ by complex conjugation, a homeomorphism of $\mathbf{CP}(m)$ onto itself.

10. Stable holomorphic flows on $\mathbf{CP}(m)$.

Here we prove case A of theorem II:

Theorem II A. — *The holomorphic flow $\mathcal{F}(\Lambda)$ on $\mathbf{CP}(m)$ is stable in case $\partial\mathcal{H}(\Lambda)$ is a convex $(m+1)$ -gon.*

Proof. — Let $\lambda_0, \lambda_1, \dots, \lambda_m$ be cyclic successive vertices of $\mathcal{H}(\Lambda)$ (fig. 4). Let O_k be the singular point $\{z : z_j = 0, j \neq k, z_k = 1\} \in \mathbf{CP}(m)$ and let $O_k O_\ell$ denote the “edge”, a cylinder $\{z : z_j = 0 \text{ for } j \neq k, \ell, z_k \neq 0, z_\ell \neq 0\}$. The flow \mathcal{F}_k on $z_k \neq 0$, as expressed in (29), has a singularity at O_k , and it is in the case of the Poincaré domain as described in § 6. Thus the leaf of a “general” point z (that is: $z_j \neq 0 \forall j$) wraps around the axes (=“edges”) $O_{k-1} O_k$ and $O_k O_{k+1}$ while converging to them. This

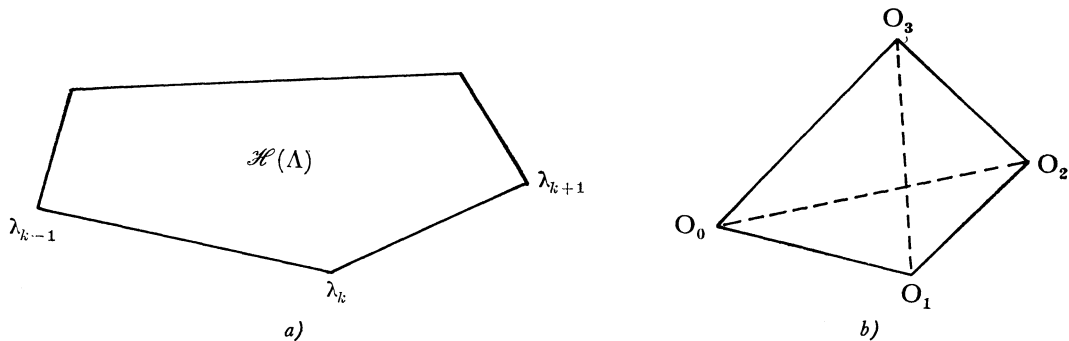

FIG. 4

being the case for all k we see that a general leaf wraps around and converges to all “edges” of the “ $(m+1)$ -gon” O_0, O_1, \dots, O_m , and converges to all vertices as well. Projecting into $\mathbf{RP}(m)$ by taking absolute values of all coordinates we get the interior of an embedded two-disc whose boundary is the ordinary $(m+1)$ -gon O_0, O_1, \dots, O_m of the \mathbf{R} -coordinate simplex in $\mathbf{RP}(m)$ (fig. 4 b).

In § 6 we saw that the topology of \mathcal{F}_k is completely determined by the 1-flow in which it meets the “sphere” $S = S_k$; in homogeneous coordinates:

$$S_k : \{z : |z_k| = \sup_{j \neq k} |z_j|\}.$$

The intersection of a leaf with S_k is represented in the T-plane by a convex unbounded polygon:

$$C_k = \partial D_k \subset \mathbf{C}$$

boundary of the disc $D_k \subset \mathbf{C}$ that represents the intersection with

$$B_k = \{z : |z_k| = \sup_j |z_j|\} \subset \mathbf{CP}(m).$$

As $\bigcup_k B_k = \mathbf{CP}(m)$, therefore $\bigcup_k D_k = \mathbf{C}$ for a "general" leaf.

We now define the *graph* $GR = GR(z)$ of a leaf of a point $z \in \mathbf{CP}(m)$ as the union:

$$GR = \bigcup_k C_k = \{T \in \mathbf{C} : \exists k : |z_k| = \sup_{j \neq k} |z_j|\}.$$

In fig. 5 we give some example of graphs.

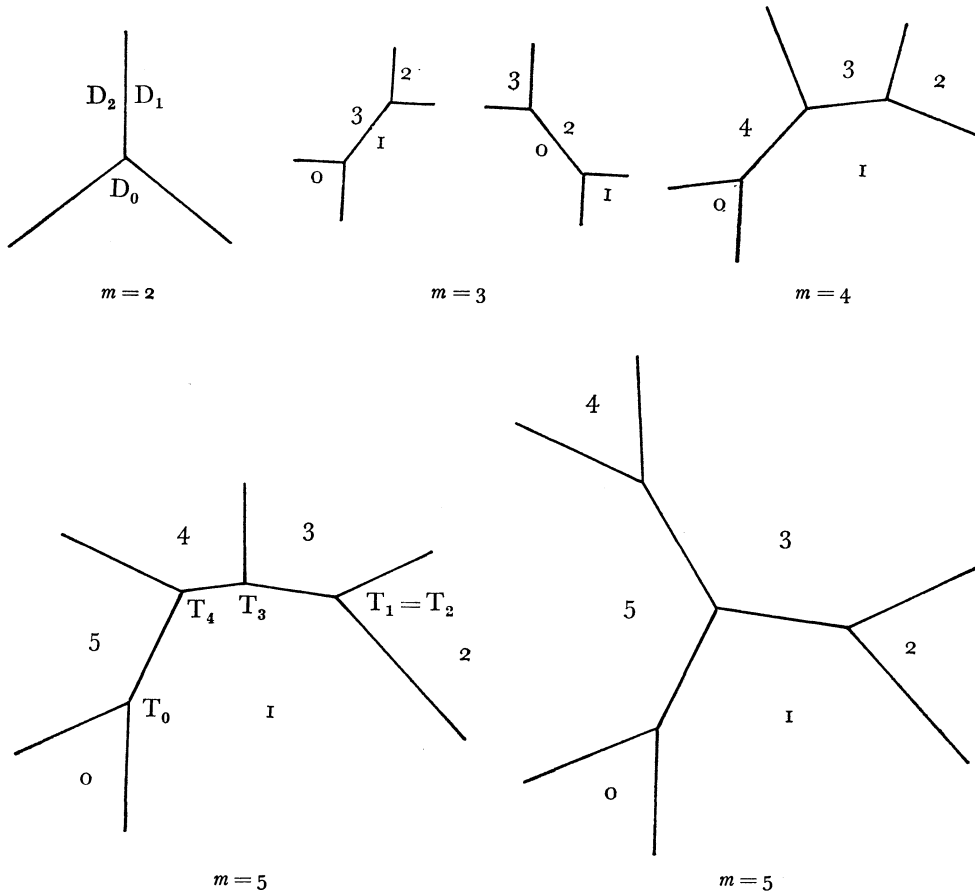

FIG. 5

The intersection $D_j \cap D_k \subset \mathbf{C}$ is either an interval parallel to the vector

$$\hat{\lambda}_{jk} = 2\pi i(\lambda_j - \lambda_k)^{-1}$$

with end points T_{1jk} and (see (29) and fig. 6):

$$T_{2jk} = T_{1jk} + \tilde{n}_{jk} \cdot 2\pi i (\lambda_j - \lambda_k)^{-1} \quad (31)$$

for some $0 < \tilde{n}_{jk} \leq \infty$, or a point and we put $\tilde{n}_{jk} = 0$, or empty and \tilde{n}_{jk} is not defined. For cyclic successors k and $k+1$, $\tilde{n}_{k,k+1}$ is ∞ .

Let T_k denote the endpoint of the infinite segment $D_k \cap D_{k+1}$ (fig. 5 and 6):

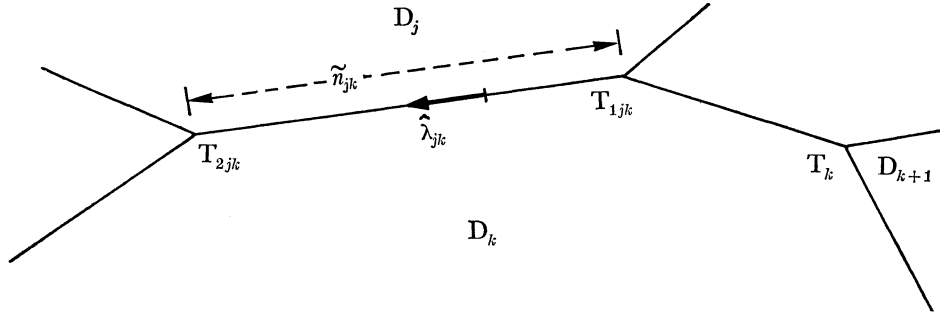

FIG. 6

We intersect the graph with a huge convex 2-disc which is then divided in $e_2 = m+1$ cells, and has e_0 vertices and e_1 edges, including $m+1$ vertices and $m+1$ edges on the boundary of the disc. The Euler characteristic of the disc is $1 = e_0 - e_1 + e_2$. In general every vertex is on three edges: $3e_0 = 2e_1$. Then the number of vertices is $e_0 = 2m$. Among these are $m-1$ vertices of GR. There are $e_1 = 3m$ edges, of which $m+1$ on the boundary of the disc and $m+1$ leading to this boundary. There remain $m-2$ bounded edges on GR giving rise to $m-2$ positive numbers \tilde{n}_{jk} , for $m-2$ specific pairs of indices j, k . Given this set, any $m-2$ positive numbers \tilde{n}_{jk} yield up to translation a unique graph GR compatible with $\Lambda : D_j \cap D_k$ is parallel to $\hat{\lambda}_{jk}$. By admitting values $\tilde{n}_{jk} = 0$ for some of these index pairs we cover also the cases where more than three edges meet in a vertex.

For z such that $z_j \neq 0$ for all j , we know that in its leaf:

$$\left| \frac{z_{k+1}}{z_k} \right| (T_k) = 1 \quad \text{for } k = 0, \dots, m$$

and we define the argument φ_k by:

$$\left(\frac{z_{k+1}}{z_k} \right) (T_k) = e^{i\varphi_k}.$$

Lemma 5 a. — Let Λ be given. The leaf of $z \in \mathcal{S} = \bigcup_k S_k$, $z_j \neq 0 \forall j$, determines and is determined by the set of “coordinates” $\{\tilde{n}_{jk}\}$, a set of $m-2$ non negative numbers, for a specific set of index pairs (j, k) , and the m arguments $\varphi_j \bmod 2\pi$, $j = 0, \dots, m-1$.

That the leaf z determines the “coordinates” is clear. Now suppose the

“coordinates” given. Given Λ , the numbers \tilde{n}_{jk} for a given k determine the convex disc D_k but for translations. We attach D_k to D_{k+1} along the common infinite edge for $k=0, 1, \dots, m-1$. The finite sides fit also. We see that the $m-2$ numbers \tilde{n}_{jk} determine the graph GR but for translations. Knowing φ_k , we know

$$z_{k+1}/z_k$$

at the point $T_k \in \text{GR}$. But in any other point $T \in \text{GR}$ we read from the formula:

$$(z_{k+1}/z_k)(T) = e^{(\lambda_{k+1} - \lambda_k)(T - T_k)} (z_{k+1}/z_k)(T_k).$$

So for every point $T \in \text{GR}$ we know without ambiguity $z_1/z_0, z_2/z_1, \dots, z_m/z_{m-1}$, that is the set of non-zero homogeneous coordinates

$$(z_0, z_1, \dots, z_m).$$

If the point T is on $D_j \cap D_k$ with vertex $T_{1jk} \in \mathbf{C}$, then T as well as the corresponding point $z \in \mathbf{C}^m$ can be characterized by $0 \leq t \leq \tilde{n}_{jk}$ for which

$$T = T_{1jk} + t2\pi i(\lambda_j - \lambda_k)^{-1}. \quad (32)$$

For a point z for which some (at most $m-2$) coordinates vanish, the same considerations apply to the remaining (at least three) non-zero coordinates, its leaf, its graph (with less domains D_k), etc. We get therefore:

Lemma 5. — *Let Λ be given. The leaf of a point $z \in \mathcal{S} = \bigcup_k S_k$ with $m' + 1$ (at least three) non-zero coordinates determines and is determined by:*

$$J(z) = \{j : z_j \neq 0\},$$

$m' - 2$ non negative numbers \tilde{n}_{jk} , and m' arguments $\varphi_k \bmod 2\pi$, $j, k \in J(z)$.

Now let Λ, Λ' be given and let $\partial\mathcal{H}(\Lambda)$ and $\partial\mathcal{H}(\Lambda')$ be convex $(m+1)$ -gons. Define a 1-1 correspondence $h : \mathcal{S} \rightarrow \mathcal{S}$ by the identity in terms of the “coordinates” of lemma 5 and the coordinate t of (32) on $D_j \cap D_k$ outside the “edges”, and by the ordinary identity map on $O_k \cap \mathcal{S}$.

End of the proof. — Clearly h maps $S_k \subset \mathcal{S}$ onto itself. It is not exactly the same as the map h which we defined on S in § 6, but the same continuity arguments remain valid. So $h|S_k$ is a homeomorphism and it extends to a leaf preserving homeomorphism of B_k onto itself for each k (cone). This combines into the required homeomorphism:

$$h : (\mathbf{CP}(m), \mathcal{F}(\Lambda)) \rightarrow (\mathbf{CP}(m), \mathcal{F}(\Lambda')).$$

In case B of theorem II, we let $(\lambda_k =) \lambda_0 = 0$ be in the interior of $\mathcal{H}(\lambda_1, \dots, \lambda_m)$ and we proceed as above. C_k is a convex polygon, unbounded for $k \neq 0$, bounded or empty in general in case $k = 0$. The graph $\text{GR}(z)$ of a leaf may therefore contain one cycle whose numbers \tilde{n}_j then necessarily obey:

$$\sum_j \tilde{n}_j \lambda_j^{-1} = 0.$$

Apart from some special care concerning the case where C_0 is empty, the proof of II B follows the above pattern.

III. — NON LINEAR FLOWS NEAR A SINGULARITY IN DIMENSION $m=3$

II. A simple solution of a formal power series problem (m general).

We now start the study of the topology of a flow near a singularity at $o \in \mathbf{C}^m$, defined by:

$$\frac{dz}{dT} = F(z) = \sigma z + R(z) \in \mathbf{C}^m, \quad z \in \mathbf{C}^m \quad (33)$$

where F is holomorphic, $F(o) = o$, $\sigma z = (DF)_o z$ is the first term of the Taylor series of F and R is the rest. We assume again for the eigenvalues of σ :

$$i \neq j \Rightarrow \lambda_i \notin \mathbf{R}\lambda_j, \quad i, j = 1, \dots, m. \quad (7)$$

In suitable linear coordinates (33) is expressed as:

$$\frac{dz_j}{dT} = \lambda_j z_j + \varphi_j(z_1, \dots, z_m), \quad j = 1, \dots, m \quad (34)$$

φ_j is considered as a convergent power series starting with terms of degree ≥ 2 :

$$\varphi_j(z) = \sum_{\mathbf{Q}} \varphi_{j\mathbf{Q}} z^{\mathbf{Q}},$$

where $\mathbf{Q} = (q_1, \dots, q_m)$, $z^{\mathbf{Q}} = z_1^{q_1} z_2^{q_2} \dots z_m^{q_m}$ is of degree $\|\mathbf{Q}\| = q_1 + q_2 + \dots + q_m$ in z_1, \dots, z_m .

Formal power series lemma 6 (known). — *There exists a unique solution in formal power series:*

$$z_j = w_j + \zeta_j(w_1, \dots, w_m), \quad \zeta_j = \sum_{\|\mathbf{Q}\| \geq 2} \zeta_{j\mathbf{Q}} w^{\mathbf{Q}}, \quad j = 1, \dots, m \quad (35)$$

which transforms (34) into

$$\frac{dw_j}{dT} = \lambda_j w_j + \psi_j(w_1, \dots, w_m), \quad \psi_j = \sum_{\|\mathbf{Q}\| \geq 2} \psi_{j\mathbf{Q}} w^{\mathbf{Q}} \quad (36)$$

$$\begin{aligned} \text{where} \quad \psi_{j\mathbf{Q}} &= 0 & \text{in case} \quad \delta_{j\mathbf{Q}} \stackrel{\text{def}}{=} q_1 \lambda_1 + \dots + q_m \lambda_m - \lambda_j \neq 0 \\ \text{and} \quad \zeta_{j\mathbf{Q}} &= 0 & \text{in case} \quad \delta_{j\mathbf{Q}} = 0. \end{aligned} \quad (37)$$

Proof. — Substitution of (35) in (34) yields with (36):

$$\frac{dw_j}{dT} + \sum_k \frac{\partial \zeta_j}{\partial w_k} (\lambda_k w_k + \psi_k) = \lambda_j (w_j + \zeta_j) + \varphi_j(w_1 + \zeta_1, \dots, w_m + \zeta_m).$$

Subtract (36) to get:

$$\sum_k \frac{\partial \zeta_j}{\partial w_k} \lambda_k w_k - \lambda_j \zeta_j + \psi_j = \varphi_j(w_1 + \zeta_1, \dots) - \sum_k \frac{\partial \zeta_j}{\partial w_k} \psi_k. \quad (38)$$

As $\sum_k \left(\frac{\partial}{\partial w_k} w^Q \right) \lambda_k w_k - \lambda_j w^Q = \delta_{jQ} w^Q$, we find the equivalent equations:

$$\sum_Q (\delta_{jQ} \zeta_{jQ} + \psi_{jQ}) w^Q = \varphi_j(w_1 + \zeta_j, \dots) - \sum_k \frac{\partial \zeta_j}{\partial w_k} \psi_k. \quad (38)$$

The terms on the right hand side of degree $\|Q\| = n$ do not involve coefficients of terms of $\zeta_j, \psi_j, j=1, \dots, m$, of degrees $\geq n$. By (37) we compute unique values ζ_{jQ} and ψ_{jQ} for $\|Q\| = n$, once we know them for $\|Q\| < n$.

The unique power series ζ_j and ψ_j satisfy (38). From (38) with (34) and (35) we can deduce the equations ($j=1, \dots, m$):

$$W_j + \sum_{k=1}^m \frac{\partial \zeta_j}{\partial w_k} W_k = 0 \quad \text{for} \quad W_i = \frac{dw_i}{dT} - \lambda_i w_i - \psi_i.$$

The determinant of the coefficient matrix is near one for (w_1, \dots, w_m) near $(0, 0, \dots, 0)$, so that (36) holds:

$$W_j = 0, \quad j=1, \dots, m.$$

Our unique power series give solutions indeed, and lemma 9 is proved.

12. Holomorphic normal forms for $m=3$.

First normal form: Lemma 7. — If $m=3$, $0 \in \mathcal{H}(\lambda_1, \lambda_2, \lambda_3)$, (7), then there exists a holomorphic change of coordinates (35) near $0 \in \mathbf{C}^3$, transforming (34) into the (not unique) normal form:

$$\frac{dw_j}{dT} = \lambda_j w_j + w_1 w_2 w_3 \chi_j, \quad j=1, 2, 3 \quad (39)$$

$\chi_j = \chi_j(w_1, w_2, w_3)$ holomorphic near $0 \in \mathbf{C}^3$.

Proof. — Because $0 \in \mathcal{H}(\lambda_1, \lambda_2, \lambda_3)$, we conclude from geometry in the plane \mathbf{C} that if $\delta_{1Q} = (q_1 - 1)\lambda_1 + q_2\lambda_2 + q_3\lambda_3$, $|\delta_{1Q}| < \delta$ and $\delta > 0$ small, then

$$q_1 \geq 2, \quad q_2 \geq 1, \quad q_3 \geq 1$$

and similarly for $j=2, 3$. The ideal Ψ generated by the polynomial $w_1 w_2 w_3$ contains therefore among others all polynomials $w^Q = w_1^{q_1} w_2^{q_2} w_3^{q_3}$ for which $|\delta_{jQ}| < \delta$ for some j .

As in § 11 there is a formal power series solution (35) transforming (34) into (36), but now, instead of (37), such that

$$\zeta_{jQ} = 0 \quad \text{if} \quad w^Q \in \Psi, \quad \psi_{jQ} = 0 \quad \text{if} \quad w^Q \notin \Psi \quad (40)$$

because all small divisors $|\delta_{jQ}| < \delta$ (in particular zero divisors) are avoided in the computation of ζ_j from (38). In order to prove that ζ_j is convergent near $0 \in \mathbf{C}^3$, we use the following notations concerning power series ξ . The series $\bar{\xi}$ (in Siegel's notation $[\bar{\xi}]$, see [14]) is

obtained from ξ by replacing each coefficient by its absolute value. $\bar{\bar{\xi}}$ is obtained from $\bar{\xi}$ by taking all arguments equal ($w_j = w$ for $j = 1, \dots, m$):

$$\bar{\bar{\xi}}(w) = \bar{\xi}(w, w, \dots, w).$$

We write (with Siegel) $\xi \prec \eta$ to express that $|\xi_Q| \leq |\eta_Q| = \eta_Q$ for all Q . Clearly if $\bar{\bar{\xi}}$ is convergent near $o \in \mathbf{C}$, then $\bar{\xi}$ is convergent near $o \in \mathbf{C}^m$, and then ξ is convergent near $o \in \mathbf{C}^m$.

From (38) and $|\delta_{jQ}| \geq \delta$ we obtain:

$$\delta \bar{\bar{\zeta}}_j \prec \sum_Q \delta_{jQ} |\zeta_{jQ}| w^Q + \bar{\psi} \prec \bar{\varphi}_j(w_1 + \bar{\zeta}_1, \dots) + \sum_k \frac{\partial \bar{\zeta}_j}{\partial w_k} \bar{\psi}_k. \quad (41)$$

The power series at the extreme left has no terms in the ideal Ψ . So we can delete the last part in the form at extreme right which is in Ψ , and obtain:

$$\delta \bar{\bar{\zeta}}_j \prec \bar{\varphi}_j(w_1 + \bar{\zeta}_1, w_2 + \bar{\zeta}_2, \dots).$$

Hence
$$\sum_j \bar{\bar{\zeta}}_j \prec \delta^{-1} \sum_j \bar{\varphi}_j(w + \bar{\zeta}_1 + \dots + \bar{\zeta}_m, w + \bar{\zeta}_1 + \dots + \bar{\zeta}_m, \dots). \quad (42)$$

We define a new power series $u = u(w) = \sum_{n \geq 1} u_n w^n$ by:

$$wu = \sum_j \bar{\bar{\zeta}}_j. \quad (43)$$

Recall that $\sum_j \varphi_j(w_1, \dots, w_m)$ is given, convergent near o , and it begins with terms of degree ≥ 2 . Therefore $A_0 > 0$ and $A > 0$ exist such that:

$$\delta^{-1} \cdot \sum_j \bar{\bar{\varphi}}_j(w) \prec \frac{A_0 w^2}{1 - Aw}. \quad (44)$$

(42), (43) and (44) yield

$$\begin{aligned} wu &\prec \frac{A_0(w + wu)^2}{1 - A(w + wu)} \\ u &\prec \frac{A_0 w(1 + u)^2}{1 - Aw(1 + u)} = A_0 w(1 + u)^2 \sum_{k=0}^{\infty} (Aw(1 + u))^k. \end{aligned} \quad (45)$$

We compare (45) with the equation for the power series $v(w) = \sum_{n=1}^{\infty} v_n w^n$, $v(0) = 0$:

$$v = \frac{A_0 w(1 + v)^2}{1 - Aw(1 + v)} = A_0 w(1 + v)^2 \sum_{k=0}^{\infty} (Aw(1 + v))^k. \quad (46)$$

$v(w)$ is unique and convergent near $o \in \mathbf{C}$ because

$$v_1 = \left(\frac{dv}{dw} \right)_{w=0} = A_0 \neq 0.$$

By choosing $A_0 > 0$ big enough we find $v_k > u_k > 0$ for the first non zero coefficient u_k of u . Then by induction with respect to n while reading and comparing (45) and (46)

we obtain the majoration $v_n \geq u_n \geq 0$ for all n . Then u , $\bar{\zeta}_j$, $\bar{\psi}_j$ and ζ_j are convergent near 0 and lemma 9 is proved.

We push the normalisation further in the

Second normal form: Lemma 8. — *With the conditions of lemma 7 there exists a holomorphic change of coordinates (35) near $0 \in \mathbf{C}^3$ transforming (34) into the normal form*

$$\frac{dw_j}{dT} = \lambda_j w_j (1 + w_1 w_2 w_3 \chi_j) \quad j=1, 2, 3. \quad (47)$$

Proof. — By lemma 7 we can assume for (34):

$$\frac{dz_j}{dT} = \lambda_j z_j + \varphi_j, \quad \varphi_j \in \Psi', \quad j=1, 2, 3. \quad (48)$$

Again we formally solve:

$$\sum_Q (\delta_{jQ} \zeta_{jQ} + \psi_{jQ}) w^Q = \varphi_j(w_1 + \zeta_1, w_2 + \zeta_2, \dots) + \sum_k \frac{\partial \zeta_k}{\partial w_k} \psi_k \quad (35)$$

but now instead of (37) or (40) we claim

$$\zeta_{jQ} = 0 \quad \text{if } w^Q \in \Psi'_j, \quad \psi_{jQ} = 0 \quad \text{if } w^Q \notin \Psi'_j$$

where $\Psi'_j \subset \Psi'$ is the ideal generated by $z_j z_1 z_2 z_3$. We can solve because $|\delta_{jQ}| > \delta > 0$ for $w^Q \notin \Psi'_j$!

By induction with respect to $\|Q\| = n$ we see that the formal power series ζ_j belongs to Ψ' , and for all Q , by construction, $\zeta_{jQ} \neq 0$ implies that $\zeta_{jQ} w^Q \notin \Psi'_j$. For $j=1$ for example we can therefore write

$$\zeta_1 = w_1 w_2 w_3 \xi_{23}(w_2, w_3)$$

$$\psi_k = w_k w_1 w_2 w_3 \chi_k(w_1, w_2, w_3)$$

and consequently for $k=1, 2, 3$, $\frac{\partial \zeta_j}{\partial w_k} \psi_k$ has a factor $w_1^2 w_2^2 w_3^2$ and belongs to the ideal Ψ^2 .

So does $\frac{\partial \zeta_j}{\partial w_k} \psi_k$ for $j=2, 3$. The power series ζ_j has no terms in $\Psi^2 \supset \Psi'_j$. We can then repeat the arguments with the equations (41)-(46), neglecting terms in Ψ^2 , and conclude the convergence of ζ_j $j=1, 2, 3$ near $0 \in \mathbf{C}^3$. Lemma 10 is proved.

13. Local stability of codimension two.

Theorem III. — *The foliation $\mathcal{F}(F)$ defined by a holomorphic vector field $F(z)$ near $0 \in \mathbf{C}^3$, with singularity at 0 such that the set of eigenvalues $\{\lambda_1, \lambda_2, \lambda_3\}$ of $(Df)_0 = \sigma$ is in the Siegel domain, is locally homeomorphic to the foliation of its linear part $\mathcal{F}(\sigma)$. The invariant $\Delta (= \eta)$ of chapter I characterises the topology completely. $\mathcal{F}(F)$ is locally stable of codimension two.*

By lemma 8 we can assume (34) in the form

$$\frac{dz_j}{dT} = \lambda_j z_j (1 + z_1 z_2 z_3 \chi_j), \quad j=1, 2, 3. \quad (49)$$

The three coordinate planes are invariant and they already contain linear vector fields. There exist $0 < \varepsilon_0 < 1$ and $K > 0$ such that $\chi_j(z_1, z_2, z_3)$ is convergent and $|\chi_j| < K$ for $\sup_i |z_i| < \varepsilon_0$. Assume $\varepsilon_0 K < 1$. By substituting $\varepsilon^3 z_j$ for z_j , $j=1, 2, 3$ with $0 < \varepsilon < \varepsilon_0$, we obtain new equations instead of (49) with new functions χ_j for which we can assume convergence in the "unit ball" $\sup_j |z_j| \leq 1$ and moreover:

$$|\chi_j| < \varepsilon^8. \quad (50)$$

We will first construct a homeomorphism h_1 of S onto S , carrying the leaves of $\mathcal{F}_1(F) = \mathcal{F}(F) \cap S$ onto those of $\mathcal{F}_1(\sigma) = \mathcal{F}(\sigma) \cap S$, and which is the identity on $V_1 = V \cap S$, where

$$V = \{z : z_1 z_2 z_3 = 0\}.$$

Our strategy will be to let h_1 preserve the strata of S and to let h_1 be identity on $\{z : |z_1| = |z_3| = 1\}$ (see fig. 7).

The first part of theorem III will then follow from general considerations, and the last part is a consequence of theorem I.

For later estimation purposes we write the unit disc in \mathbf{C} :

$$\theta = \{u \in \mathbf{C} : |u| \leq 1\} \quad (51)$$

and $f(\theta) = \{f(u) : u \in \theta\}$ for any function f of $u \in \mathbf{C}$.

We assume $\arg \hat{\lambda}_1 < \arg \lambda_2 < \arg \hat{\lambda}_3 < \arg \hat{\lambda}_1 + 2\pi$ so that with $\hat{\lambda}_j = 2\pi i \lambda_j^{-1}$:

$$\operatorname{Re} \lambda_2 \hat{\lambda}_1 > 0, \quad \operatorname{Re} \lambda_3 \hat{\lambda}_1 < 0. \quad (52)$$

The leaves of $\mathcal{F}(\sigma)$ are transversal to S except at the points where $|z_1| = |z_2| = |z_3| = 1$. The same holds for the slightly perturbed $\mathcal{F}(F)$. Any 1-leaf in S meets $|z_3| = |z_1| = 1$ in at most one point $z(T_0) = (z_1(T_0), z_2(T_0), z_3(T_0))$ with parameter value T_0 say; it meets $|z_1| = |z_2| = 1$ in $z(T_1)$; it meets $|z_2| = |z_3| = 1$ in $z(T_2)$. This will be made clear in the following calculations. We start at $t=0$ from a point:

$$z(T_0) = (e^{i\alpha_1}, e^{i\alpha_2 - N}, e^{i\alpha_3}), \quad N > 0. \quad (53)$$

We shall perform the calculations only in the special case $\alpha_1 = \alpha_2 = \alpha_3 = 0$, hence

$$z(T_0) = (1, e^{-N}, 1). \quad (53')$$

The general case (53) is formally but not essentially more complicated. We follow its 1-leaf in S with respect to $\mathcal{F}(F)$ in $|z_1| = 1$, substitute

$$z_1 = e^{2\pi i t}, \quad t \geq 0 \quad (54)$$

in (49), and find:

$$2\pi i = \frac{d \ln z_1}{dt} = \lambda_1 (1 + z_1 z_2 z_3 \chi_1) \frac{dT}{dt}.$$

If $\varepsilon > 0$ is small enough, depending only on $\lambda_1, \lambda_2, \lambda_3$, then (see (50) and (51))

$$\frac{dT}{dt} = \hat{\lambda}_1 (1 + z_1 z_2 z_3 \chi_1)^{-1} \in \hat{\lambda}_1 + \varepsilon^7 \sup |z_1 z_2 z_3| \theta \quad (55)$$

$$\frac{dT}{dt} \in \hat{\lambda}_1 + \varepsilon^7 \theta. \quad (56)$$

The sup is here over the segment from T_0 to T_1 where, as we see below in (57), $|z_2|$ increases up to its value 1 at T_1 at which we set $t = \tilde{n}_1$. Similarly $|z_3|$ decreases between T_0 and T_1 . In the T-plane the curve from T_0 to T_1 is for small ε almost parallel to $\hat{\lambda}_1$ by (56). See fig. 7.

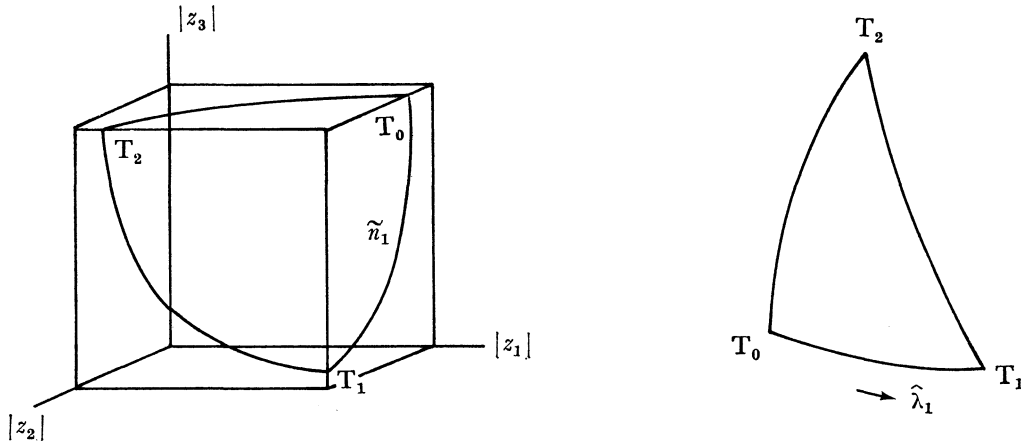

FIG. 7

Next we use (55) and the equation (49) for z_2 to get, for small $\varepsilon > 0$:

$$\frac{d \ln z_2}{dt} = \lambda_2 (1 + z_1 z_2 z_3 \chi_2) \frac{dT}{dt} \in \lambda_2 \hat{\lambda}_1 + \varepsilon^6 \sup |z_1 z_2 z_3| \theta \subset \lambda_2 \hat{\lambda}_1 + \varepsilon^6 \theta. \quad (57)$$

We integrate:

$$\ln z_2 \in -N + (\lambda_2 \hat{\lambda}_1 + \varepsilon^6 \sup |z_1 z_2 z_3| \theta) t \subset -N + (\lambda_2 \hat{\lambda}_1 + \varepsilon^6 \theta) t \quad (58)$$

$$\ln |z_2| < -N + (\operatorname{Re} \lambda_2 \hat{\lambda}_1 + \varepsilon^6) t \stackrel{\text{def}}{=} -N + \gamma_2 t, \quad \gamma_2 > 0. \quad (59)$$

Analogously for z_3 :

$$\ln z_3 \in (\lambda_3 \hat{\lambda}_1 + \varepsilon^6 \sup |z_1 z_2 z_3| \theta) t \subset (\lambda_3 \hat{\lambda}_1 + \varepsilon^6 \theta) t \quad (60)$$

$$\ln |z_3| < (\operatorname{Re} \lambda_3 \hat{\lambda}_1 + \varepsilon^6) t \stackrel{\text{def}}{=} -\gamma_3 t, \quad \gamma_3 > 0. \quad (61)$$

From (59) and (61) it follows that

$$\gamma_2 \ln |z_2| + \gamma_3 \ln |z_3| < -\gamma_2 N.$$

As $\ln|z_1|=1$, $\ln|z_2|\leq 0$, $\ln|z_3|\leq 0$:

$$\begin{aligned} \ln|z_1 z_2 z_3| &= \ln|z_2| + \ln|z_3| < \max\left(-1, -\frac{\gamma_2}{\gamma_3}\right) \cdot N \stackrel{\text{def}}{=} -\gamma_4 N \\ \sup|z_1 z_2 z_3| &< e^{-\gamma_4 N}. \end{aligned} \quad (62)$$

$|z_2(T_1)|=1$ for $t=\tilde{n}_1$, and substituting (62) in (58) gives an estimate for \tilde{n}_1 :

$$0 = \ln|z_2(T_1)| \in -N + (\operatorname{Re} \lambda_2 \hat{\lambda}_1 + \varepsilon^6 e^{-\gamma_4 N} \theta) \tilde{n}_1 \subset -N + \operatorname{Re} \lambda_2 \hat{\lambda}_1 (1 + \varepsilon^5 e^{-\gamma_4 N} \theta) \tilde{n}_1.$$

Then for ε small enough:

$$\tilde{n}_1 < \frac{2N}{\operatorname{Re} \lambda_2 \hat{\lambda}_1}, \quad \text{hence} \quad \left| \tilde{n}_1 - \frac{N}{\operatorname{Re} \lambda_2 \hat{\lambda}_1} \right| \leq \varepsilon^5 e^{-\gamma_4 N} \operatorname{Re} \lambda_2 \hat{\lambda}_1 \tilde{n}_1 \leq \varepsilon^4 N e^{-\gamma_4 N}. \quad (63)$$

The corresponding answer for a 1-leaf of $\mathcal{F}(\sigma)$ starting at the same point

$$z'(T'_0) = z(T_0) = (1, e^{-N}, 1),$$

is obtained by putting $\varepsilon=0$. We use primes for the linear case $\mathcal{F}(\sigma)$:

$$\tilde{n}'_1 = \frac{N}{\operatorname{Re} \lambda_2 \hat{\lambda}_1}. \quad (63')$$

The difference is small for large N :

$$|2\pi(\tilde{n}_1 - \tilde{n}'_1)| = |\ln z_1(T_1) - \ln z'_1(T'_1)| = |\arg z_1(T_1) - \arg z'_1(T'_1)| \leq \varepsilon^3 N e^{-\gamma_4 N}. \quad (64)$$

Substituting (62) and $t=\tilde{n}_1$ in (58) gives:

$$\begin{aligned} \ln z_2(T_1) &\in -N + (\lambda_2 \hat{\lambda}_1 + \varepsilon^6 e^{-\gamma_4 N} \theta) \tilde{n}_1 \\ \ln z'_2(T'_1) &= -N + \lambda_2 \hat{\lambda}_1 \tilde{n}'_1 \end{aligned} \quad (65)$$

$$\text{Hence} \quad |\ln z_2(T_1) - \ln z'_2(T'_1)| = |\arg z_2(T_1) - \arg z'_2(T'_1)| \leq \varepsilon^2 N e^{-\gamma_4 N}. \quad (66)$$

Substituting (62) and $t=\tilde{n}_1$ in (60) gives:

$$\begin{aligned} \ln z_3(T_1) &\in (\lambda_3 \hat{\lambda}_1 + \varepsilon^6 e^{-\gamma_4 N} \theta) \tilde{n}_1 \\ \ln z'_3(T'_1) &= \lambda_3 \hat{\lambda}_1 \tilde{n}'_1 = N \lambda_3 \hat{\lambda}_1 / \operatorname{Re} \lambda_2 \hat{\lambda}_1 \end{aligned} \quad (67)$$

$$\text{Hence} \quad |\ln z_3(T_1) - \ln z'_3(T'_1)| \leq \varepsilon^2 N e^{-\gamma_4 N}. \quad (68)$$

We conclude from (64), (66) and (68) that the mapping $z(T_1) \rightarrow z'(T'_1)$ of

$$S \cap \{z : |z_2|=|z_1|=1, z_3 \neq 0\}$$

onto itself tends to the identity map in $z_3=0$ (for $N \rightarrow \infty$). This is equally true starting from (53) instead of (53'). The same calculations for the 1-leaf segments $T_0 T_2$ in $|z_3|=1$ give the analogous conclusions for the mapping $z(T_2) \rightarrow z'(T'_2)$.

We now define the map

$$h_1 = (S, \mathcal{F}_1(F)) \rightarrow (S, \mathcal{F}_1(\sigma))$$

by the following conditions:

a) The restriction of h_1 to the union $V = \{z : z_1 z_2 z_3 = 0\}$ of the Poincaré leaves is the identity.

b) h_1 leaves invariant each stratum of the stratification of S by $|z_j|=1$, $j=1, 2, 3$.

c) On the stratum $|z_1|=|z_3|=1$, h_1 is the identity map. In our notation *c)* means $h_1(z(T_0))=z'(T'_0)=z(T_0)$. As every Siegel 1-leaf in S meets $|z_3|=|z_1|=1$, *c)* determines for each Siegel $\mathcal{F}_1(F)$ -leaf its image $\mathcal{F}_1(\sigma)$ -leaf. In view of *b)* we have by intersection:

$$h_1(z(T_1))=z'(T'_1) \quad \text{if} \quad |z_2|=|z_1|=1, \quad z_3 \neq 0 \text{ at } z(T_1).$$

This agrees continuously with the identity at $z_3=0$ (see *a)*). Similarly for

$$h_1(z(T_2))=z'(T'_2).$$

d) A point on the edge T_0T_1 of an $\mathcal{F}_1(F)$ -leaf with total z_1 -argument-length $2\pi\tilde{n}_1$, is determined by a rotation number t , $0 \leq t \leq \tilde{n}_1$, if we start from $z(T_0)$, or $\tilde{n}-t$ if we start from $z(T_1)$ (see (54)). It is analogous for the edges T_1T_2 and T_2T_0 by cyclic permutation of 1, 2 and 3=0. The same applies to the linear case $\mathcal{F}(\sigma)$, which we continue to distinguish in the notation by primes. The action of h_1 on the points of an $\mathcal{F}_1(F)$ -leaf onto its image $\mathcal{F}_1(\sigma)$ -leaf, is given by proportional rotation numbers:

$$t'_j/t_j = \tilde{n}'_j/\tilde{n}_j, \quad j=1, 2, 3.$$

For $n \rightarrow \infty$ these quotients converge to 1. (64) tells this for $j=1$. For $j=3$ it follows by studying T_0T_2 instead of T_0T_1 . The value $2\pi\tilde{n}_2$ is the z_2 -argument difference between $z(T_0)$ and $z(T_2)$, which can be read also going along two edges via $z(T_1)$. The formulas then tell again that also \tilde{n}'_2/\tilde{n}_2 tends to 1 for $N \rightarrow \infty$.

If we keep $t=t_j$ or \tilde{n}_j-t_j fixed for some j and let N go to ∞ , then the map of the initial point in the $\mathcal{F}_1(F)$ -leaf converges to the identity map of a point of a Poincaré- $\mathcal{F}_1(F)$ -leaf in V . Therefore h_1 agrees continuously with the identity map on V , it is continuous as is its inverse. Then h_1 is the desired homeomorphism.

There remains to define with the help of h_1 a homeomorphism $h : \mathcal{F}(F) \rightarrow \mathcal{F}(\sigma)$ near $o \in \mathbb{C}^3$. Let U_ρ be the neighborhood of V in $B = \{z : \sup_j |z_j| \leq 1\}$ that is the union of all $\mathcal{F}(F)$ -leaves in B at euclidean distance ($\|z\|^2 = \sum_j |z_j|^2$) smaller than some ρ with $0 < \rho < \frac{1}{2}$ from $o \in \mathbb{C}^3$. The restriction $\mathcal{F}(F)|_{U_\rho}$ is transversal to S and to $S_\tau = \{z : \|z\| = \tau\}$ for $\tau > \rho$. Recall that in each Siegel leaf of $\mathcal{F}(\sigma)$ the function $\|z\|$ has exactly one critical point, where $\|z\|$ has a minimum, and the critical points form together a manifold M . These two properties are stable under our small perturbations and hold equally well for $\mathcal{F}(F)$. This can be seen also by a calculation of $d \sum_j z_j \bar{z}_j = 0$. Call the manifold of nearest Siegel leaf points M^F . First observe that:

$$\mathcal{F}(F) \Big| \left(U_\rho \cap \left\{ z : \|z\| > \frac{1}{2} \right\} \right)$$

is homeomorphic (\simeq) to $\mathcal{F}_1(F) \times \left[\frac{1}{2}, 1 \right]$. Extend this homeomorphism with the help of the $\|z\|$ -gradient lines in each $\mathcal{F}(F)$ -leaf in U_ρ to obtain a homeomorphism:

$$\mathcal{F}(F) | (U_\rho \setminus M^F \cup o) \simeq \mathcal{F}_1(F) \times (0, 1].$$

The union of the Siegel leaves in this foliation is a trivial 2-disc fibration with base space $U_\rho \cap M^F$ from which a cross-section $U_\rho \cap M^F$ is deleted. We recover it by compactifying each Siegel-leaf with one point, and we recover $\mathcal{F}(F)|U_\rho$ by compactifying the space so obtained with one more point, the origin $o \in \mathbf{C}^3$. The foliation $\mathcal{F}(F)|U_\rho$ of $\mathcal{F}(F)$ near o is now up to topological equivalence completely determined by $\mathcal{F}_1(F)|(U_\rho \cap S)$, and the same holds for $\mathcal{F}(\sigma)$. Therefore the existence of h_1 carries with itself the existence of a homeomorphism of $\mathcal{F}(F)|U_\rho$ onto $\mathcal{F}(\sigma)|U'_\rho$ where U'_ρ is obtained from σ in the same way as U_ρ from F . Theorem III is proved.

IV

14. Holomorphic reduction to normal forms, $m \geq 3$.

We terminate this paper with the necessary preparation for a proof (that we hope to give later) of the stability of codimension $2m-4$ for Siegel domain type singularities of vector fields on \mathbf{C}^m , $m > 3$ (see footnote (1) on page 8).

Theorem (IV.1). — Given, as before, near $o \in \mathbf{C}^m$, the equations

$$\frac{dz}{dT} = F : \frac{dz_j}{dT} = \lambda_j z_j + \varphi_j, \quad i \neq j \Rightarrow \lambda_i \notin \mathbf{R}\lambda_j, \quad i, j = 1, \dots, m \quad (7), (34)$$

we can assume after a suitable holomorphic change of coordinates that the union $V(F)$ of the Poincaré leaves and the axes equals the unperturbed set

$$V(\sigma) = V = \{z : \text{if } \{j_1, \dots, j_r\} = \{j : z_j \neq 0\}, \text{ then } o \notin \mathcal{H}(\lambda_{j_1}, \dots, \lambda_{j_r})\}.$$

This follows from the reduction to normal form:

Theorem (IV.2). — Assuming (7), (34), there is a holomorphic change of coordinates

$$z_j = w_j + \zeta_j(w_1, \dots, w_m) \quad (35)$$

transforming (34) into

$$\frac{dw_j}{dT} = \lambda_j w_j + \psi_j + \chi_j \quad (69)$$

such that $\psi_j(w_1, \dots, w_m)$ is in Ψ , the ideal in the ring of convergent power series generated by the monomials $w_i w_k w_\ell$ for which $o \in \mathcal{H}(\lambda_i, \lambda_k, \lambda_\ell)$,

$$\psi_j = \sum_{o \in \mathcal{H}(\lambda_i, \lambda_k, \lambda_\ell)} w_i w_k w_\ell \zeta_{jikt},$$

and $\chi_j(w_1, \dots, w_m)$ is a sum of scalar multiples of terms, finite in number,

$$w^Q = w_{j_1}^{q_1} w_{j_2}^{q_2}, \dots, w_{j_r}^{q_r}, \quad q_1 > 0, \dots, q_r > 0,$$

for which δ_{jQ} is a Poincaré zero divisor:

$$\delta_{jQ} = q_1 \lambda_{j_1} + \dots + q_r \lambda_{j_r} - \lambda_j = 0 \quad (70)$$

and there is an open half plane for some $\omega \in \mathbf{R}$:

$$\{\lambda \in \mathbf{C} : \operatorname{Re} e^{i\omega} \lambda > 0\} \quad (71)$$

to which $\lambda_{j_1}, \dots, \lambda_{j_r}$ and λ_j belong.

Corollary. — *The theorem of Dulac* [4]. This is the special Poincaré domain case $0 \notin \mathcal{H}(\lambda_1, \dots, \lambda_m)$, for which Ψ is empty, hence $\psi_j = 0$ in (69).

Proof of $V \subset V(F)$ in theorem (IV.1), from (IV.2).

We shall assume that the vector field F has the form (69) with the condition of theorem (IV.2). The set V is a finite union of maximal linear subspaces, and we first prove that any one of them, say V_0 , is invariant under F . There is no loss of generality in assuming that V_0 is defined by equations

$$V_0 : z_{r+1} = \dots = z_m = 0 \quad (72)$$

for some r , which implies that, for some ω ,

$$\lambda_i \in \{\lambda : \operatorname{Re} e^{i\omega} \lambda > 0\}, \quad \text{for } 1 \leq i \leq r. \quad (73)$$

We have to prove that, on V_0 , (72) implies that

$$\frac{dz_j}{dT} = 0 \quad \text{for } j \geq r+1.$$

To see this substitute (72) in the right hand side of:

$$\frac{dz_j}{dT} = \lambda_j z_j + \psi_j + \chi_j, \quad j \geq r+1.$$

Then $\lambda_j z_j = 0$; $\psi_j = 0$ because the definition of Ψ implies that every term in ψ_j contains one of the z_ℓ for which $\operatorname{Re} e^{i\omega} \lambda_\ell \leq 0$, that is $\ell > r$ and $z_\ell = 0$; $\chi_j = 0$ because if it has a nonzero term $cz^Q = cz_1^{q_1} \dots z_r^{q_r}$ then $\operatorname{Re}(e^{i\omega} \delta_{jQ}) = \operatorname{Re}(e^{i\omega}(q_1 \lambda_1 + \dots + q_r \lambda_r - \lambda_j)) > 0$ and δ_{jQ} cannot be zero. Then the left hand side vanishes as well.

The nonlinear vector field F defines in the invariant part (73) of V a Poincaré domain vector field near 0 . So this part, like any part near 0 of V , lies in $V(F)$ and:

$$V \subset V(F).$$

We do not give the proof here of the stronger assertion:

$$V = V(F)$$

which is an elaborate calculation.

Proof of theorem (IV.2). — As in § 11 we can obtain a (unique) formal solution for ζ_j from equations (38) but now with the conditions

$$\begin{aligned} \psi_{jQ} &= 0 & \text{if } w^Q \notin \Psi, \\ \zeta_{jQ} &= 0 & \text{if } w^Q \in \Psi \quad \text{or if } \delta_{jQ} = 0, \\ \lambda_{jQ} &= 0 & \text{if } w^Q \in \Psi \quad \text{or if } \delta_{jQ} \neq 0. \end{aligned}$$

We have to prove that ζ_j is convergent near $0 \in \mathbf{C}^m$ for $j = 1, \dots, m$.

We first prove the

Lemma 9. — *There exist $n_0 > 0$ and $\delta > 0$ such that if*

$$w^Q \notin \Psi, \quad \delta_{jQ} \neq 0, \quad \|Q\| = q_1 + \dots + q_m \geq n_0,$$

then $|\delta_{jQ}| > \delta \cdot \|Q\|$.

As $w^Q = w_1^{q_1} \dots w_r^{q_r} \notin \Psi$, $q_1 > 0, \dots, q_r > 0$, we conclude that $\lambda_{j_1}, \dots, \lambda_{j_r}$ are contained in some open half plane $\{\lambda : \operatorname{Re} e^{i\omega} \lambda > 0\}$. If λ_j is *not* in that half plane, hence $\operatorname{Re} e^{i\omega} \lambda_j \leq 0$, then:

$$\begin{aligned} |\delta_{jQ}| &> \operatorname{Re} e^{i\omega} \delta_{jQ} = \operatorname{Re} e^{i\omega} (q_1 \lambda_{j_1} + \dots + q_r \lambda_{j_r} - \lambda_j) \\ &\geq \operatorname{Re} e^{i\omega} (q_1 \lambda_{j_1} + \dots + q_r \lambda_{j_r}) \\ &\geq \|Q\| \min(\operatorname{Re} e^{i\omega} \lambda_{j_1}, \dots, \operatorname{Re} e^{i\omega} \lambda_{j_r}) \stackrel{\text{def}}{=} \|Q\| \delta_\omega > 0. \end{aligned}$$

If λ_j is *in* that half plane, hence $\operatorname{Re} e^{i\omega} \lambda_j = C_{\omega j} > 0$, then for $\|Q\| > n_0$ large:

$$\begin{aligned} |\delta_{jQ}| &> \operatorname{Re} e^{i\omega} \delta_{jQ} = \operatorname{Re} e^{i\omega} (q_1 \lambda_{j_1} + \dots + q_r \lambda_{j_r}) - \operatorname{Re} e^{i\omega} \lambda_j \\ &\geq \|Q\| \delta_\omega - C_{\omega j} > \|Q\| \left(\delta_\omega - \frac{C_{\omega j}}{n_0} \right). \end{aligned}$$

We need to consider only a finite number of half planes, that is of values of ω , and can choose $\delta > 0$ small and n_0 big to satisfy lemma 9.

We make a preliminary change of coordinates by finite polynomials, to arrange that ζ_{jQ} will be 0 for $\|Q\| \leq n_0$, below. We can do this because we can do it in formal finite power series.

Next we proceed as in § 12. In order to prove that ζ_j is convergent, it suffices to prove the convergence of $\bar{\zeta}_j = \sum_Q |\zeta_{jQ}| \cdot w^Q$, hence of $\bar{\zeta}_j = \sum_{n \geq 2} \bar{\zeta}_{jn} w^n$ (where $\bar{\zeta}_j$ is defined as in § 12, which means $\bar{\zeta}_{jn} = \sum_{\|Q\|=n} |\zeta_{jQ}|$), hence of $u = u(w)$ defined by (the factor n will be needed below!):

$$wu = \sum_j \sum_{n \geq n_0} n \bar{\zeta}_{jn} w^n. \quad (74)$$

(With respect to notation we recall that: w^Q means $w_1^{q_1} \dots w_m^{q_m}$, whereas w^n means the n -th power of one variable w .)

For the calculation to follow we also observe that if we let $w_1 = w_2 = \dots = w_m = w$, $\|Q\| = q_1 + \dots + q_m = n$, then $w_1^{q_1} w_2^{q_2} \dots w_m^{q_m} = w^n$, and

$$\sum_k \frac{\partial}{\partial w_k} (w_1^{q_1} w_2^{q_2} \dots w_m^{q_m}) = \sum_k \frac{\partial}{\partial w_k} (w_1^{q_1} w_2^{q_2} \dots w_m^{q_m}) \frac{\partial w_k}{\partial w} = \frac{\partial w^n}{\partial w} = n w^{n-1} \quad (75)$$

For example:

$$\sum_{\|Q\|=n} \left(\sum_k \frac{\partial \zeta_{jQ}}{\partial w_k} w^Q \right) = n \bar{\zeta}_{jn} w^n \cdot w^{-1}.$$

We study the solutions of (38) modified according to (69):

$$\sum_{\mathbb{Q}} \delta_{j\mathbb{Q}} \zeta_{j\mathbb{Q}} w^{\mathbb{Q}} + \psi_j + \chi_j = \varphi_j(w_1 + \zeta_1, \dots, w_m + \zeta_m) - \sum_k \frac{\partial \zeta_j}{\partial w_k} (\psi_k + \chi_k).$$

We replace coefficients of all formal power series in this equation by their absolute values, delete all terms of the ideal Ψ that we see, use the lemma, and apply obvious majorations to obtain (compare § 11):

$$\begin{aligned} \delta \sum_{\mathbb{Q}} \|Q\| \cdot |\zeta_{j\mathbb{Q}}| \cdot w^{\mathbb{Q}} &< \sum_{\mathbb{Q}} |\delta_{j\mathbb{Q}} \bar{\zeta}_{j\mathbb{Q}}| w^{\mathbb{Q}} \\ &< \bar{\varphi}_j(w_1 + \bar{\zeta}_1, \dots, w_m + \bar{\zeta}_m) + \left(\sum_k \frac{\partial \bar{\zeta}_j}{\partial w_k} \right) \left(\sum_l \bar{\chi}_l \right). \end{aligned} \quad (76)$$

We sum (76) over j , substitute $w_1 = w_2 = \dots = w_m = w$, use (74) and (75) and apply considerable majorations. We also use that, for some $A_0 > 0$ and $A > 0$,

$$\delta^{-1} \sum_j \bar{\varphi}_j(w) < \frac{A_0 w^2}{1 - Aw},$$

and:

$$\overline{\sum_j \sum_k \frac{\partial \zeta_j}{\partial w_k}} = \sum_{j,n} \frac{\partial \bar{\zeta}_j}{\partial w} w^n = w u \cdot w^{-1} = u.$$

Then we find:

$$\begin{aligned} w u &< \frac{A_0 (w + w u)^2}{1 - A(w + w u)} + u \left(\sum_k \bar{\chi}_k / \delta \right) \\ u &< \frac{A_0 w (1 + u)^2}{1 - Aw(1 + u)} + u \left(\sum_k \bar{\chi}_k / \delta w \right). \end{aligned} \quad (77)$$

$\sum_k \bar{\chi}_k$ is a (finite) polynomial in w , that starts with terms of degree ≥ 2 . Now compare (77) with the equation for $v = \sum_1^{\infty} v_n w^n$:

$$v = \frac{A_0 w (1 + v)^2}{1 - Aw(1 + v)} + v \left(\sum_k \bar{\chi}_k / \delta w \right) \quad (78)$$

which has a convergent solution near $w = 0$, because

$$\left(\frac{dv}{dw} \right)_{w=0} = A_0 \neq 0.$$

For $A_0 > 0$ big enough we obtain:

$$v_r > u_r, \quad r \geq n_0$$

where u_r is the first nonzero term of the power series u .

Then by comparing (77) and (78) we find by induction on $n : 0 \leq u_n < v_n$, and also u is convergent. Then ζ_j ($j = 1, \dots, m$) is convergent, and theorem (IV.2) is proved.

REFERENCES

- [1] A. D. BRJUNO, Analytical form of differential equations, *Trudy Moscow Math. Obšč (Trans. Moscow Math. Soc.)*, vol. 25 (1971), p. 131-288.
- [2] C. CAMACHO, N. H. KUIPER, J. PALIS, La topologie du feuilletage d'un champ de vecteurs holomorphe près d'une singularité, *C.R. Acad. Sc. Paris*, t. 282 A, p. 959-961.
- [3] Topological properties of \mathbf{R}^2 -actions are studied in:
 C. CAMACHO, On $\mathbf{R}^k \times \mathbf{Z}^l$ -actions, *Proceed. Symp. on Dynamical Systems*, Salvador 1971, Ed. Peixoto, p. 23-70.
 G. PALIS, Linearly induced vector fields and \mathbf{R}^2 -actions on spheres, to appear in *J. Diff. Geom.*
 C. CAMACHO, Structural stability theorems for integrable differential forms on 3-manifolds, to appear in *Topology*.
- [4] H. DULAC, Solutions d'un système d'équations différentielles dans le voisinage des valeurs singulières, *Bull. Soc. Math. France*, **40** (1912), 324-383.
- [5] J. GUCKENHEIMER, Hartman's theorem for complex flows in the Poincaré domain, *Compositio Math.*, **24** (1972), p. 75-82.
- [6] A real analogue of theorem III is the classical Grobman-Hartman theorem:
 P. HARTMAN, *Proc. AMS*, **11** (1960), p. 610-620.
- [7] Topological properties of real linear flows on \mathbf{R}^n are studied in:
 N. H. KUIPER, *Manifolds Tokyo, Proceedings Int. Conference, Math. Soc. Japan* (1973), p. 195-204, and:
 N. N. LADIS, *Differentsialnye Uravneniya Volg.* (1973), p. 1222-1235.
- [8] D. LIEBERMAN, Holomorphic vector fields on projective varieties, *Proc. Symp. Pure Math.*, XXX (1976), 273-276.
- [9] The invariant of chapter I goes back to an invariant in the study of stability in one parameter families of diffeomorphisms :
 S. NEWHOUSE, J. PALIS, F. TAKENS, to appear. See also:
 J. PALIS, *A differentiable invariant of topological conjugacies and moduli of stability*, preprint IMPA.
- [10] J. PALIS, S. SMALE, Structural stability theorems, *Global Analysis, Symp. Pure Math.*, AMS, vol. XIV (1970), p. 223-231.
- [11] H. POINCARÉ, Sur les propriétés des fonctions définies par les équations aux différences partielles, thèse, Paris, 1879 = *Œuvres complètes*, I, p. xcix-cv.
- [12] H. RUSSMANN, *On the convergence of power series transformations of analytic mappings near a fixed point into a normal form*, Bures-sur-Yvette, preprint I.H.E.S.
- [13] C. L. SIEGEL, Über die Normalform analytischer Differentialgleichungen in der Nähe einer Gleichgewichtslösung, *Göttingen, Nachr. Akad. Wiss., Math. Phys. Kl.* (1952), p. 21-30.
- [14] C. L. SIEGEL, J. MOSER, *Celestial mechanics* (1971) (English edition of: C. L. SIEGEL, *Vorlesungen über Himmelsmechanik*, 1954, Springer Verlag).
- [15] Ю. С. Ильяшенко ЗАМЕЧАНИЯ О ТОПОЛОГИИ ОСОБЫХ ТОЧЕК АНАЛИТИЧЕСКИХ ДИФФЕРЕНЦИАЛЬНЫХ УРАВНЕНИЙ В КОМПЛЕКСНОЙ ОБЛАСТИ И ТЕОРЕМА ЛАДИСА, *Функциональный анализ и его приложения*, Т. 11, Вып 2, 1977, 28-38.
- [16] J. GUCKENHEIMER, On holomorphic vector fields on $\mathbf{CP}(2)$, *An. Acad. Brasil. Cienc.*, **42** (1970), p. 415-420.
- [17] F. DUMORTIER, R. ROUSSARIE, Smooth linearization of germs of \mathbf{R}^2 -actions and holomorphic vector fields, to appear.

Manuscrit reçu le 6 septembre 1977.