

# COMPOSITIO MATHEMATICA

G. J. HECKMAN

## **Root systems and hypergeometric functions. II**

*Compositio Mathematica*, tome 64, n° 3 (1987), p. 353-373

[http://www.numdam.org/item?id=CM\\_1987\\_\\_64\\_3\\_353\\_0](http://www.numdam.org/item?id=CM_1987__64_3_353_0)

© Foundation Compositio Mathematica, 1987, tous droits réservés.

L'accès aux archives de la revue « Compositio Mathematica » (<http://www.compositio.nl/>) implique l'accord avec les conditions générales d'utilisation (<http://www.numdam.org/conditions>). Toute utilisation commerciale ou impression systématique est constitutive d'une infraction pénale. Toute copie ou impression de ce fichier doit contenir la présente mention de copyright.

NUMDAM

Article numérisé dans le cadre du programme  
Numérisation de documents anciens mathématiques

<http://www.numdam.org/>

## Root systems and hypergeometric functions II

G. J. HECKMAN

*Mathematisch Instituut, Rijksuniversiteit Leiden, Niels Bohrweg 1, 2333 CA Leiden, The Netherlands*

Received 19 August 1986; accepted in revised form 22 July 1987

### 1. Introduction

We keep the notation as in [HO]. Consider the differential operator

$$L(k) = \sum_{j=1}^n \partial(X_j)^2 - \sum_{\alpha \in R_+} k_\alpha (1 + h^\alpha)(1 - h^\alpha)^{-1} \partial(X_\alpha) \quad (1.1)$$

and the associated differential equation

$$L\phi = (\lambda - \varrho, \lambda + \varrho)\phi. \quad (1.2)$$

Substituting a formal solution of the form  $\phi(\mu, k; h) = \sum_{v \geq \mu} \Gamma_v(\mu, k) h^v$  with  $\Gamma_\mu(\mu, k) = 1$  gives the equations

$$(\mu, \mu - 2\varrho) = (\lambda - \varrho, \lambda + \varrho) \quad (1.3)$$

$$\{(\mu - \varrho, \mu - \varrho) - (v - \varrho, v - \varrho)\} \Gamma_v(\mu, k) \quad (1.4)$$

$$= 2 \sum_{\alpha \in R_+} k_\alpha \sum_{j=1}^{\infty} (v - j\alpha, \alpha) \Gamma_{v-j\alpha}(\mu, k)$$

and the series  $\phi(\mu, k; h)$  converges absolutely on  $A_-$  for almost all  $\mu$ . The main result of this paper is the following theorem.

**THEOREM 1.1:** *For almost all  $\mu \in \mathfrak{h}^*$  the function  $\phi(\mu, k; h)$  is a Nilsson class function on  $H^{\text{reg}}$ , and the space  $\mathbb{C}\text{-span} \{ \phi(w(\mu - \varrho) + \varrho, k; h); w \in W \}$  is stable under the monodromy of  $\Pi_1(H^{\text{reg}})$ . Moreover, putting  $\lambda = \mu - \varrho$ , the function*

$$F(\lambda, k; h) = \sum_{w \in W} c(w\lambda, k) \phi(w\lambda + \varrho, k; h) \quad (1.5)$$

*extends from  $A_-$  to a Weyl group invariant analytic function on all of  $A$ .*

DEFINITION 1.2: The above function  $F(\lambda, k; h)$  is called the hypergeometric function with parameters  $\lambda$  and  $k$  associated to the root system  $R$ .

Let me describe an outline of the proof of the above theorem. In the first place, the fundamental group  $\Pi_1(W \setminus H^{\text{reg}})$  has been described by van der Lek and Looijenga in terms of generators and relations [vdL]. The resulting group is called the extended Artin group, and an important feature of this group is that the relations allow a reduction to rank 2. In [HO] the function (1.5) was studied under the crucial assumption of the existence of sufficiently many differential operators commuting with  $L$  (Conjecture 2.10 of [HO]). By brute force calculations this assumption has been verified for rank 2 (see [Op]). Now one can conclude that the monodromy representation of the functions in Theorem 1.1 indeed defines a representation of the extended Artin group. At this point one can apply the Riemann–Hilbert correspondence as proved by Deligne (see [D]) to obtain the existence of a Nilsson class function of the given monodromy type. The final step consists of modifying this function in such a way that in addition it also satisfies the differential equation (1.2).

The details of the above proof are written in Section 2 up to Section 7. As an application of Theorem 1.1 we prove in Section 8 the associated Plancherel formula for the compact torus.

## 2. The Riemann–Hilbert correspondence

In this section we review some of the ideas of Deligne on differential equations with regular singular points [D]. Let  $X$  be a non singular compact connected complex algebraic variety. Let  $Y \subset X$  be a divisor and write  $Z = X \setminus Y$  for the complement. Fix a base point  $z_0 \in Z$ . Let  $f(z)$  be an analytic function around  $z_0$ . We assume that  $f(z)$  extends to a multivalued analytic function on  $Z$ , i.e. for each continuous curve  $s(t): [0, 1] \rightarrow Z$  with begin point  $s(0) = z_0$  the function  $f(z)$  has an analytic continuation along  $s$ . We write  $M(s)f(z)$  for the analytic function around  $z_1 = s(1)$  obtained by analytic continuation of  $f(z)$  along  $s$ . Clearly  $M(s)f(z)$  depends only on the homotopy class with fixed end points of the curve  $s$ . In particular for  $s \in \Pi_1(Z, z_0)$  we have an analytic function  $M(s)f(z)$  around  $z_0$ , which is called a determination of  $f(z)$  around  $z_0$ . It is clear that  $M(s_1)M(s_2)f(z) = M(s_1s_2)f(z)$  for  $s_1, s_2 \in \Pi_1(Z, z_0)$ . Here the composition  $s_1s_2$  is defined by  $s_1s_2(t) = s_2(2t)$  for  $0 \leq t \leq \frac{1}{2}$ , and  $s_1s_2(t) = s_1(2t - 1)$  for  $\frac{1}{2} \leq t \leq 1$ . Write  $V$  for the linear span of all determinations  $M(s)f(z)$  around  $z_0$ ,  $s \in \Pi_1(Z, z_0)$ . If  $d = \dim(V)$  is finite, then  $f(z)$  is called of finite determination.

In this case we obtain a finite dimensional representation  $M: \Pi_1(Z, z_0) \rightarrow GL(V)$  defined by  $s \rightarrow M(s)$  and which is called the monodromy representation. Clearly  $v = f(z)$  considered as a vector in  $V$  is a cyclic vector for the monodromy representation. We say that  $f(z)$  has monodromy type  $(V, M, v)$ . Multivalued analytic functions of finite determination arise naturally as solutions of a holonomic system of differential equations.

DEFINITION 2.1: A Nilsson class function  $f(z)$  on  $(Z, z_0)$  is a multivalued analytic function on  $Z$  with base point  $z_0 \in Z$  of finite determination and having moderate growth along  $Y = X \setminus Z$ .

Nilsson class functions arise naturally as solutions of a holonomic system of differential equations with regular singularities. The following result is Deligne’s version of the Riemann–Hilbert correspondence [D].

THEOREM 2.2: Let  $V$  be a vector space of dimension  $d < \infty$ . Let  $M: \Pi_1(Z, z_0) \rightarrow GL(V)$  be a representation, and  $v \in V$  a cyclic vector for this representation. Then the set of all meromorphic Nilsson class functions on  $(Z, z_0)$  of monodromy type subordinated to  $(V, M, v)$  is a vector space of dimension  $d$  over the field  $\mathbb{C}(X)$  of rational functions on  $X$ .

REMARK 2.3: For  $Z = \mathbb{P}_1(\mathbb{C}) \setminus \{a, b, c\}$  and  $\dim(V) = 2$  the theorem essentially amounts to the theory of the Riemann  $P$ -function [R]. For  $Z = \mathbb{P}_1(\mathbb{C}) \setminus \{a_1, \dots, a_n\}$  the theorem is due to Hilbert and Plemelj [P].

### 3. Boundary values of Nilsson class functions

We keep the notation of the previous section. Let  $y_0 \in Y$  be a fixed point such that  $Y$  has normal crossings near  $y_0$ . If  $z = (z_1, \dots, z_n)$  are local coordinates around  $y_0$ , then there exists an  $\varepsilon > 0$  such that for  $U = \{z = (z_1, \dots, z_n); |z_i| < 2\varepsilon \forall i\}$  we have  $Y \cap U = \{z \in U; z_1 \dots z_k = 0\}$  for some  $k$  with  $1 \leq k \leq n$ . Take  $z_0 = (\varepsilon, \dots, \varepsilon, 0, \dots, 0) \in U$  as a base point for  $Z$  (the first  $k$  coordinates equal to  $\varepsilon$ , the last  $n - k$  equal to 0), and let  $U_0 = \{z \in U; |z_i - \varepsilon| < \varepsilon \text{ for } i = 1, \dots, k\}$ . (See Figure 1).

Clearly the local fundamental group  $\Pi_1(U \setminus Y, z_0)$  is abelian with generators  $t_j(t) = (\varepsilon, \dots, \varepsilon, \varepsilon e^{2\pi it}, \varepsilon, \dots, \varepsilon, 0, \dots, 0)$  for  $0 \leq t \leq 1, j = 1, \dots, k$  (the  $\varepsilon e^{2\pi it}$  on the  $j$ th place).

Let  $f(z)$  be a Nilsson class function on  $(Z, z_0)$  of determination order  $d$ . Let  $V$  be the vector space of dimension  $d$ , spanned by all determinations of  $f(z)$  on  $U_0$ . Let  $M_j: V \rightarrow V$  be the monodromy of  $t_j \in \Pi_1(U \setminus Y, z_0)$ . In order

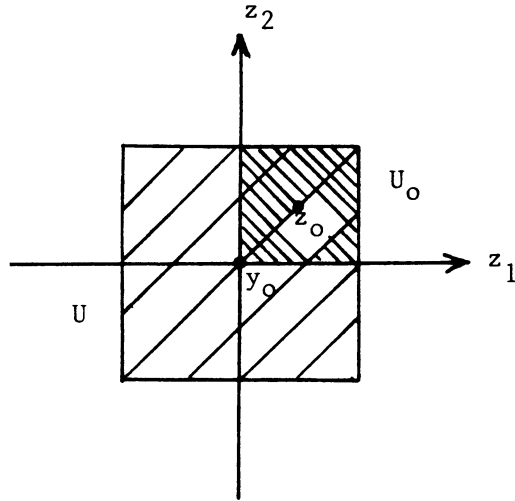

Fig. 1.

to avoid the use of logarithmic terms we assume that all  $M_j$  are semisimple. For  $s \in \mathbb{C}^k$  we write

$$z^s = z_1^{s_1} \dots z_k^{s_k} \tag{3.1}$$

in multi index notation. Let

$$V(s) = \{g \in V; g(z) = z^s \tilde{g}(z) \text{ for some } \tilde{g} \in \mathcal{O}(U)\}. \tag{3.2}$$

Here  $\mathcal{O}(U)$  denotes the ring of holomorphic functions on  $U$ . Introduce a partial ordering on  $\mathbb{C}^k$  by

$$s \leq t \Leftrightarrow t_j - s_j \in \mathbb{Z}_+ = \{0, 1, 2, \dots\}, \quad j = 1, \dots, k. \tag{3.3}$$

Clearly  $V(t) \subset V(s)$  for  $s \leq t$ .

**DEFINITION 3.1:** A vector  $s \in \mathbb{C}^k$  is called an exponent of multiplicity  $d(s)$  if  $d(s) = \dim(V(s)/\sum_{t>s} V(t)) > 0$ .

It is easy to see that  $\sum_s d(s) = d$ . From now on we assume that  $y_0$  is a regular point of  $Y$ , i.e.  $k = 1$  in the previous notation. Hence

$$V(s) = \{g \in V; g(z) = z_1^s \tilde{g}(z) \text{ for some } \tilde{g} \in \mathcal{O}(U)\} \tag{3.4}$$

for  $s \in \mathbb{C}$ .

DEFINITION 3.2: Let  $s \in \mathbb{C}$  be an exponent. The map

$$V(s)/V(s + 1) \rightarrow \mathcal{O}(Y \cap U) \tag{3.5}$$

defined by  $g(z) = z_1^s \tilde{g}(z_1, z_2, \dots, z_n) \rightarrow \tilde{g}(0, z_2, \dots, z_n)$  is called the boundary value map at  $y_0$  with respect to the exponent  $s$ . Denote  $W(s) \subset \mathcal{O}(Y \cap U)$  the image.

In view of the linear isomorphism

$$V \simeq \bigoplus V(s)/V(s + 1), \tag{3.6}$$

which is only canonical if no two exponents differ by integers, we obtain a linear injection

$$V \rightarrow \mathcal{O}(Y \cap U)^e, \tag{3.7}$$

where  $e$  is the number of exponents of  $f(z)$  at  $y_0$ . Although we have defined the notion of exponent and boundary value using local coordinates, they are in fact intrinsic. Moreover exponents and their multiplicities are locally constant along regular points of  $Y$ .

Write  $Y = \bigcup_{j \geq 1} Y_j$  with  $Y_j$  irreducible divisors. Assume  $X' = Y_1$  is non singular, and put  $Y' = (\bigcup_{j \geq 2} Y_j) \cap X'$  and  $Z' = X' \setminus Y'$ . For  $\delta > 0$  put

$$Z'_\delta = \{z \in Z'; d(z, Y') > \delta\} \tag{3.8}$$

for some metric  $d(\cdot, \cdot)$  on  $X$ . Fix a base point  $y_0 = z'_0 \in Z'$ . Choose  $\delta > 0$  such that the inclusion  $Z'_\delta \rightarrow Z'$  induces an isomorphism

$$\Pi_1(Z'_\delta, z'_0) \simeq \Pi_1(Z', z'_0). \tag{3.9}$$

For  $\varepsilon > 0$  small let  $U_\varepsilon = \{x \in X; d(x, X') < 2\varepsilon\}$  be a tubular neighborhood of  $X'$  in  $X$ , and  $p: U_\varepsilon \rightarrow X'$  the projection on  $X'$ . Put  $U_{\varepsilon, \delta} = \{x \in U_\varepsilon; p(x) \in Z'_\delta\}$ . (See Figure 2.)

Choose  $\varepsilon > 0$  such that  $U_{\varepsilon, \delta} \setminus Y = U_{\varepsilon, \delta} \setminus Z'_\delta = U_{\varepsilon, \delta}^*$ . Clearly  $p: U_{\varepsilon, \delta}^* \rightarrow Z'_\delta$  is a fiber bundle map with fiber  $D_{2\varepsilon}^* = \{z \in \mathbb{C}; 0 < |z| < 2\varepsilon\}$ . Take local coordinates  $z = (z_1, \dots, z_n)$  around  $y_0 = z'_0$ . Put  $z_0 = (\varepsilon, 0, \dots, 0)$  and  $U_0 = \{z; |z_1 - \varepsilon| < \varepsilon, |z_j| < 2\varepsilon \forall j \geq 2\}$ . By possibly shrinking  $\varepsilon > 0$  we can assume that  $U_0 \subset U_{\varepsilon, \delta}^*$ . The projection  $p: U_{\varepsilon, \delta} \rightarrow Z'_\delta$  induces a bijection

$$p_*: \Pi_1(U_{\varepsilon, \delta}, z_0) \simeq \Pi_1(Z'_\delta, z'_0) \simeq \Pi_1(Z', z'_0). \tag{3.10}$$

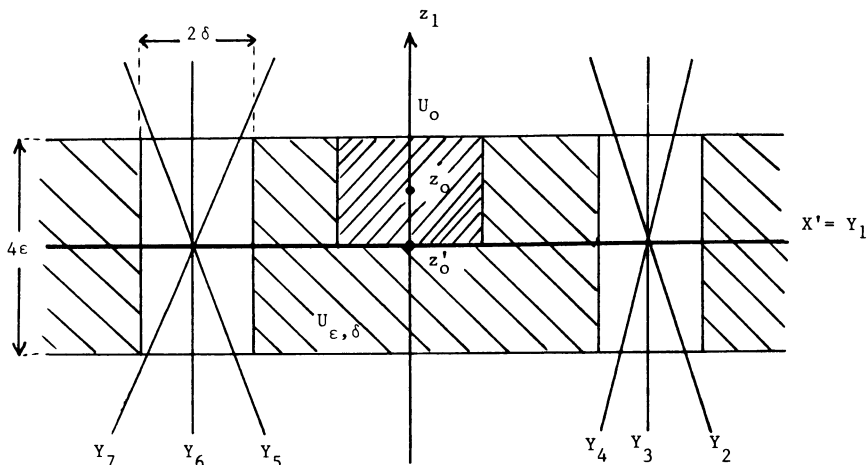

Fig. 2.

Let  $s \in \mathbb{C}$  be an exponent of  $f(z)$  at  $z'_0$ . The monodromy defines a representation of  $\Pi_1(U_{\epsilon,\delta}^*, z_0)$  on  $V(s)$ . Write

$$M(s): \Pi_1(U_{\epsilon,\delta}, z_0) \rightarrow GL(V(s)/V(s + 1)) \tag{3.11}$$

for the quotient representation on  $V(s)/V(s + 1)$ .

**THEOREM 3.3:** *The image  $W(s)$  of the boundary value map  $V(s)/V(s + 1) \rightarrow \mathcal{O}(Z' \cap U)$  defines a Nilsson class function on  $(Z', z'_0)$  of determination order  $d(s)$ . Moreover we have a commutative diagram*

$$\begin{array}{ccc} \Pi_1(U_{\epsilon,\delta}, z_0) & \xrightarrow[\text{map } M(s)]{\text{monodromy}} & GL(V(s)/V(s + 1)) \\ \downarrow p_* & & \downarrow \text{boundary value map} \\ \Pi_1(Z', z'_0) & \xrightarrow[\text{on } Z']{\text{monodromy}} & GL(W(s)) \end{array}$$

**REMARK 3.4:** The definition of boundary value for Nilsson class functions is a simple special case of the more general concept of boundary values as introduced by Kashiwara and Oshima [KO], [OS].

#### 4. The role of the central subgroup $C$

We use the notation of [HO]. Recall that  $H$  is the complex torus with character lattice  $\hat{H}$  equal to the weight lattice  $P = \{\lambda \in \mathfrak{h}^*; (\lambda, \alpha^\vee) \in \mathbb{Z}, \forall \alpha \in R\}$  of  $R$ .

The subgroup

$$C = \{h \in H; h^\alpha = 1 \forall \alpha \in R\} \tag{4.1}$$

is called the central subgroup of  $H$ , and  $H/C$  is called the adjoint torus. Denote by  $Q$  the root lattice of  $R$ . Clearly  $(H/C)^\wedge = Q$  and  $\hat{C} = P/Q$ . The following table is well known [B].

LEMMA 4.1: For  $R$  irreducible we have the table

$R$	$A_n$	$B_n$	$C_n$	$BC_n$	$D_n$ <small><math>n</math> odd</small>	$D_n$ <small><math>n</math> even</small>	$E_6$	$E_7$	$E_8$	$F_4$	$G_2$
$C$	$\mathbb{Z}_{n+1}$	$\mathbb{Z}_2$	$\mathbb{Z}_2$	1	$\mathbb{Z}_4$	$\mathbb{Z}_2 \times \mathbb{Z}_2$	$\mathbb{Z}_3$	$\mathbb{Z}_2$	1	1	1

Let  $\{\alpha_1, \dots, \alpha_n\}$  be a basis of simple roots for  $R_+$ , and write  $x_j = h^{\alpha_j}$  for  $j = 1, \dots, n$ . The map

$$x = (x_1, \dots, x_n): H/C \rightarrow \mathbb{C}^n \tag{4.2}$$

is injective with image  $\{x \in \mathbb{C}^n; x_j \neq 0 \forall j\}$ , and defines a partial compactification of  $H/C$ . Using the action of the Weyl group this extends to a global equivariant compactification of  $H/C$ , which is the toroidal compactification of  $H/C$  corresponding to the decomposition of  $a^*$  into Weyl chambers. We denote this compactification by  $X$ .

Let  $\{\lambda_1^\vee, \dots, \lambda_n^\vee\}$  be a basis of the coweight lattice  $P^\vee$  satisfying  $(\lambda_i^\vee, \alpha_j) = \delta_{ij}$ . In order to denote the dependence of the root system  $R$  we write  $H(R)$ ,  $C(R)$ ,  $W(R)$  and  $X(R)$  instead of  $H$ ,  $C$ ,  $W$  and  $X$ . Let  $R_j$  denote the parabolic subsystem of  $R$  with basis  $\{\alpha_1, \dots, \alpha_{j-1}, \alpha_{j+1}, \dots, \alpha_n\}$ . Clearly we have

$$H(R_j) \simeq H(R)/\{h \in H(R); h = \exp(tX_{\lambda_j^\vee}), t \in \mathbb{C}\} \tag{4.3}$$

and

$$H(R_j)/C(R_j) \simeq H(R)/C(R)\{h \in H(R); h = \exp(tX_{\lambda_j^\vee}), t \in \mathbb{C}\}. \tag{4.4}$$

LEMMA 4.2: The boundary components of  $H(R)/C(R)$  in  $X(R)$ , which meet the chart (4.2) are of the form  $X(R_j)$  where  $j = 1, \dots, n$ . Moreover these boundary components intersect with normal crossings.



REMARK 4.3: Let  $\pi: H \rightarrow H/C$  be the natural map. It is known that  $H^{\text{reg}} = \{h \in H; wh \neq h \forall w \in W, w \neq e\}$  is equal to the set  $\{h \in H; \Delta(h) \neq 0\}$  with  $\Delta(h)$  the Weyl denominator of  $R^0$ . If we write  $(H/C)^{\text{reg}} = \{h \in H/C; wh \neq h \forall w \in W, w \neq e\}$  then it is clear that  $\pi^{-1}(H/C)^{\text{reg}}$  is contained in  $H^{\text{reg}}$ . However the inclusion  $\pi^{-1}(H/C)^{\text{reg}} = \{h \in H; vh \neq h \forall v \in WC, v \neq e\}$  in  $H^{\text{reg}}$  can be strict (e.g. for  $R$  of type  $A_n$ ).

We now describe a procedure to relate Nilsson class functions on  $W(R) \setminus H(R)^{\text{reg}}$  to Nilsson class functions on  $W(R_j) \setminus H(R_j)^{\text{reg}}$  essentially by taking boundary values. The scheme can be indicated in a diagram.

$$\begin{array}{ccccc}
 W(R) \setminus H(R)^{\text{reg}} & \xrightarrow{f_1 \mapsto f_2} & W(R) \setminus (H(R)/C(R))^{\text{reg}} & \xrightarrow{f_2 \mapsto f_3} & (H(R)/C(R))^{\text{reg}} \\
 \downarrow f_1 \mapsto f_6 & & \downarrow f_2 \mapsto f_5 & & \downarrow f_3 \mapsto f_4 \\
 W(R_j) \setminus H(R_j)^{\text{reg}} & \xleftarrow{f_5 \mapsto f_6} & W(R_j) \setminus (H(R_j)/C(R_j))^{\text{reg}} & \xleftarrow{f_4 \mapsto f_5} & (H(R_j)/C(R_j))^{\text{reg}}
 \end{array}$$

We start with a Nilsson class functions  $f_1$  on  $W(R) \setminus H(R)^{\text{reg}}$  of determination order  $d_1$ . We restrict this function to  $\pi^{-1}(H/C)^{\text{reg}}$  and take the push forward to obtain a Nilsson class function  $f_2$  on  $W(R) \setminus (H(R)/C(R))^{\text{reg}}$ . The determination order  $d_2$  of  $f_2$  satisfies  $d_2 \leq d_1 \cdot |C|$ . Taking the boundary value of  $f_2$  relative to some exponent along  $X(R_j)$  gives a Nilsson class function  $f_5$  on  $W(R_j) \setminus (H(R_j)/C(R_j))^{\text{reg}}$ . Strictly speaking one has to lift to  $(H(R)/C(R))^{\text{reg}}$  and take the boundary value there, which commutes with the action of  $W(R_j)$  on  $(H(R)/C(R))^{\text{reg}}$  and  $(H(R_j)/C(R_j))^{\text{reg}}$ . In the chart (4.2) the boundary value should be taken with respect to the hyperplane  $x_j = 0$ . Finally the function  $f_5$  is lifted to  $W(R_j) \setminus \pi^{-1}(H(R_j)/C(R_j))^{\text{reg}}$  and the extension to  $W(R_j) \setminus H(R_j)^{\text{reg}}$  follows since the original function  $f_1$  was Nilsson class on  $W(R) \setminus H(R)^{\text{reg}}$ .

In the next sections we will carry out this inductive procedure for Nilsson class functions of a special monodromy type.

### 5. Representation theory of $\Pi_1(W \setminus H^{\text{reg}})$

In Section 5 of [HO] we reviewed the description of  $\Pi_1(W \setminus H^{\text{reg}})$  in terms of generators and relations, due to van der Lek and Looyenga [vdL]. Let  $V$  be a vector space of dimension  $d = |W|$  with basis  $\{e_w; w \in W\}$ . In the notation of Section 6 of [HO] the vector  $e_w$  represents the function  $\phi(w\lambda + \varrho, k; a)$ . In that section we explicitly computed the monodromy

representation

$$M(\lambda, k): \Pi_1(W \setminus H^{\text{reg}}) \rightarrow GL(V) \tag{5.1}$$

on the generators  $s_1, \dots, s_n$  and  $t_1, \dots, t_n$ . For  $t_j$  we found that  $e_w$  was an eigen vector of  $M(\lambda, k)(t_j)$  with eigenvalue  $\exp \{2\pi i(w\lambda + \varrho, \beta_j^\vee)\}$ . The matrices  $M(\lambda, k)(s_j)$  were a direct sum of  $2 \times 2$  matrices, and were described in Theorem 6.7 of [HO].

**THEOREM 5.1:** *For any root system  $R$  the above formulas define a representation  $M(\lambda, k): \Pi_1(W \setminus H^{\text{reg}}) \rightarrow GL(V)$ .*

*Proof:* In [HO] this result was proved under the assumption that Conjecture 2.10 is true. In [Op] the validity of Conjecture 2.10 is shown for  $R$  of rank 2. Hence the theorem holds for  $R$  of rank 2. Since the relations in  $\Pi_1(W \setminus H^{\text{reg}})$  all take place in rank 2 subsystems the theorem follows for any  $R$ . □

**REMARK 5.2:** The family of representations  $M(\lambda, k)$  of  $\Pi_1(W \setminus H^{\text{reg}})$  depends meromorphically on  $\lambda \in \mathfrak{h}^*$  and holomorphically on  $k \in K \simeq \mathbb{C}^m$ . Moreover the family is holomorphic in  $\lambda$  outside the hyperplanes  $(\lambda, \alpha^\vee) \in \mathbb{Z}$  for  $\alpha \in R$ .

**DEFINITION 5.3:** The parameter  $\lambda \in \mathfrak{h}^*$  is called admissible if  $(\lambda, \alpha^\vee) \notin \mathbb{Z}$  for all  $\alpha \in R$ . The parameter  $k \in K$  is called admissible if  $\frac{1}{2} + k_\alpha + k_{2\alpha} \notin \mathbb{Z}$  (put  $k_{2\alpha} = 0$  if  $2\alpha \notin R$ ) for all  $\alpha \in R$ .

**REMARK 5.4:** The condition for  $\lambda \in \mathfrak{h}^*$  to be admissible is necessary in order to even write down the formulas for the monodromy matrices relative to the basis  $e_w$  for  $V$ ,  $w \in W$ . The condition for  $k \in K$  to be admissible means that the monodromy around the discriminant is semisimple, i.e. the monodromy for the curves  $s_j^{-1}$  and  $t_j^{-1}s_j$  (see Fig. 1 at the end of Section 4 of [HO]). If  $(\lambda, k) \in \mathfrak{h}^* \times K$  is an admissible parameter set, then the c-functions  $c(\lambda, k)$ ,  $c(\lambda, k')$  are well defined. Here  $k'$  denotes the associated parameter of  $k$  (see Definition 2.14 of [HO]).

**LEMMA 5.5:** *Suppose  $\lambda \in \mathfrak{h}^*$  is admissible, and  $\text{Re}(\lambda) \in \overline{\mathfrak{a}_+^*}$ . Then the vector  $e_1 \in V$  is a cyclic vector for the representation  $M(\lambda, k): \Pi_1(W \setminus H^{\text{reg}}) \rightarrow GL(V)$ .*

*Proof:* By a rank 1 reduction this follows from the results of Section 4 of [HO]. □

LEMMA 5.6: For  $v \in W$  the map  $e_w \mapsto e_{vw^{-1}}$  induces an isomorphism  $M(\lambda, k) \rightarrow M(v\lambda, k)$ .

*Proof:* This is clear by a rank 1 reduction. □

Recall the definition of the function

$$\delta(k; h)^{1/2} = h^{-\varrho} \prod_{\alpha \in R_+} (1 - h^\alpha)^{k_\alpha} \tag{5.2}$$

on  $H^{\text{reg}}$  (see Proposition 2.2 of [HO].) Here  $\varrho = \varrho(k) = \frac{1}{2} \sum_{\alpha \in R_+} k_\alpha \cdot \alpha$ . Clearly  $\delta(k, h)^{1/2}$  is a Nilsson class functions on  $W \setminus H^{\text{reg}}$  of determination order 1. We denote by  $\delta(k; h)^{1/2}$  also the 1-dimensional representation of  $\Pi_1(W \setminus H^{\text{reg}})$  to which it gives rise. Recall the definition of the associated parameter  $k'$  of  $k$  (see Definition 2.14 of [HO]).

LEMMA 5.7: Let  $M(\lambda, k'): \Pi_1(W \setminus H^{\text{reg}}) \rightarrow GL(V')$  be the associated representation, and let  $e'_w$  be the natural basis for  $V'$ ,  $w \in W$ . For  $\lambda \in \mathfrak{h}^*$  admissible the map  $1 \otimes e_w \rightarrow 1 \otimes e'_w$  induces an isomorphism  $\delta(k)^{-1/2} \otimes M(\lambda, k) \simeq \delta(k')^{-1/2} \otimes M(\lambda, k')$  of representations.

*Proof:* If  $\text{rank}(R) = 1$  this follows from Proposition 2.2 of [HO]. The case  $\text{rank}(R) \geq 2$  follows by a rank 1 reduction. □

DEFINITION 5.8: Two parameter sets  $(\lambda, k), (\mu, l) \in \mathfrak{h}^* \times K$  are called contiguous if  $\lambda - \mu \in P$ , and  $k_\alpha - l_\alpha \in \mathbb{Z}$  for all  $\alpha \in R^0$ , and  $k_\alpha - l_\alpha \in 2\mathbb{Z}$  for all  $\alpha \in R \setminus R^0$ .

PROPOSITION 5.9: Suppose  $(\lambda, k)$  and  $(\mu, l)$  are admissible contiguous parameter sets in  $\mathfrak{h}^* \times K$ . Suppose for all  $\alpha \in R$  none of the functions  $c_\alpha(\lambda, k), c_\alpha(\lambda, k'), c_\alpha(\mu, k)$  and  $c_\alpha(\mu, k')$  vanish. Then the linear map  $c(w\lambda, k)e_w \mapsto c(w\mu, l)e_w$  of  $V$  onto itself induces an isomorphism  $M(\lambda, k) \simeq M(\mu, l)$  of representations.

*Proof:* Since  $\lambda - \mu, \varrho(k) - \varrho(l) \in P$  for  $(\lambda, k)$  and  $(\mu, l)$  contiguous parameters it follows easily that  $M(\lambda, k)(t_j) \mapsto M(\mu, l)(t_j)$  for  $j = 1, \dots, n$ . In order to show that  $M(\lambda, k)(s_j) \mapsto M(\mu, l)(s_j)$  it suffices to consider the rank 1 case. Using the notations of Proposition 4.4 of [HO] this amounts to

showing that the  $2 \times 2$  matrix

$$C(\lambda, k)^{-1} \begin{pmatrix} \frac{c(\lambda, k)}{c(\mu, l)} & 0 \\ 0 & \frac{c(-\lambda, k)}{c(-\mu, l)} \end{pmatrix} C(\mu, l)$$

is a diagonal matrix. This is equivalent to the condition  $c(\lambda, k)c(-\lambda, k')c(-\mu, l)c(\mu, l') = c(-\lambda, k)c(\lambda, k')c(\mu, l)c(-\mu, l')$ . A straight forward computation shows that

$$c_\alpha(\lambda, k)c_\alpha(-\lambda, k') = \frac{2(\frac{1}{2} - k_{\alpha/2} - k_\alpha) \sin \pi(-(\lambda, \alpha^\vee) + \frac{1}{2}k_{\alpha/2} + k_\alpha) \sin \pi(-(\lambda, \alpha^\vee) + \frac{1}{2}k_{\alpha/2} + \frac{1}{2})}{(\lambda, \alpha^\vee) \cdot \sin \pi(\frac{1}{2} + k_{\alpha/2} + k_\alpha) \sin 2\pi(\lambda, \alpha^\vee)}$$

for  $\alpha \in R^0$ , and the above condition follows easily. □

**6. Connection with the differential operator  $L(k)$**

In this section we assume that  $(\lambda, k) \in \mathfrak{h}^* \times K$  is an admissible parameter set. Consider the representation

$$M(\lambda, k): \Pi_1(W \setminus H^{\text{reg}}) \rightarrow GL(V) \tag{6.1}$$

obtained in Theorem 5.1. Since this representation depends only on the Weyl group orbit of  $\lambda$  in  $\mathfrak{h}^*$  it is no restriction to assume that  $\text{Re}(\lambda) \in \overline{\mathfrak{a}_+^*}$ . By Lemma 5.5 we know that  $e_1$  is a cyclic vector for this representation. Now we can apply Theorem 2.2 to obtain a Nilsson class function  $G(h)$  on  $A_-$  of monodromy type  $(V, M(\lambda, k), e_1)$  relative to  $\Pi_1(W \setminus H^{\text{reg}})$ . The main purpose of this section is to obtain from  $G(h)$  another Nilsson class function  $F(h)$  of the same monodromy type as  $G(h)$ , which is moreover an eigenfunction of the differential operator (see Section 2 of [HO])

$$L = L(k) = \sum_{j=1}^n \partial(X_j)^2 - \sum_{\alpha \in R_+} k_\alpha (1 + h^\alpha)(1 - h^\alpha)^{-1} \partial(X_\alpha). \tag{6.2}$$

Since  $G(h)$  is only a meromorphic Nilsson class function (on the complement of a divisor in  $\mathbb{C}^n$ ) a first remark is that possible poles of  $G(h)$  outside

the discriminant disappear by multiplying  $G(h)$  by a suitable polynomial. Hence  $G(h)$  becomes an analytic Nilsson class function on the complement of the discriminant.

As indicated in Fig. 1 at the end of Section 4 of [HO] the curves  $s_j^{-1}$  and  $t_j^{-1}s_j$  go once around the discriminant in a positive way. On the 2-dimensional subspace  $\mathbb{C}$ -span  $\{e_w, e_{r_j w}\}$  the monodromy matrices  $M(\lambda, k)(s_j^{-1})$  and  $M(\lambda, k)(t_j^{-1}s_j)$  have eigenvalues 1 and  $\exp(2\pi i(\frac{1}{2} - k_{\beta_j/2} - k_{\beta_j}))$ , and 1 and  $\exp(2\pi i(\frac{1}{2} - k_{\beta_j}))$  respectively. Here  $\{\beta_1, \dots, \beta_n\}$  is a basis of simple roots for  $R^0$ , and  $k_{\beta_j/2} = 0$  if  $\frac{1}{2}\beta_j \notin R$ . Let  $G(w; h)$  be the function on  $A_-$  corresponding to the vector  $e_w$ ,  $w \in W$ . Let  $(a_{j,w}, b_{j,w})$  be the exponents of the functions span  $\mathbb{C} \{G(w; h), G(r_j w; h)\}$  for the monodromy matrix  $M(s_j^{-1})$  such that  $a_{j,w} \in \mathbb{Z}$ , and  $b_{j,w} - (\frac{1}{2} - k_{\beta_j/2} - k_{\beta_j}) \in \mathbb{Z}$ . Similarly let  $(c_{j,w}, d_{j,w})$  be the exponents for the monodromy matrix  $M(\lambda, k)(t_j^{-1}s_j)$  such that  $c_{j,w} \in \mathbb{Z}$ , and  $d_{j,w} - (\frac{1}{2} - k_{\beta_j}) \in \mathbb{Z}$ . Let  $\Delta(h)$  denote the Weyl denominator for  $R^0$ . Multiplying  $G(h)$  by  $\Delta(h)^{2N}$ ,  $N \in \mathbb{Z}_+$  large, we can assume that the exponents  $a_{j,w}, b_{j,w}, c_{j,w}, d_{j,w}$  satisfy

$$a_{j,w}, b_{j,w} - (\frac{1}{2} - k_{\beta_j/2} - k_{\beta_j}), c_{j,w}, d_{j,w} - (\frac{1}{2} - k_{\beta_j}) \in \mathbb{Z}_+ \tag{6.3}$$

$\forall j = 1, \dots, n, \forall w \in W$ . The resulting function is again denoted by  $G(h)$ .

After these two elementary modifications of the function  $G(h)$ , we can make a first connection between the operator  $L(k)$  and the function  $G(h)$ .

**LEMMA 6.1:** *The function  $LG(h)$  is a Nilsson class function of the same monodromy type as  $G(h)$ , and the exponents of  $LG(h)$  along the discriminant also satisfy condition (6.3).*

*Proof:* The first statement is obvious since the operator  $L$  has trivial monodromy and polynomial coefficients (see Lemma 2.1 of [HO]). The fact that the exponents  $a_{j,w}$  and  $c_{j,w}$  of  $LG(h)$  again lie in  $\mathbb{Z}_+$  also follows from Lemma 2.1 of [HO]. Using Corollary 2.15 of [HO] and Lemma 5.7 condition (6.3) for the exponents  $b_{j,w}$  and  $d_{j,w}$  of  $LG(h)$  can be reduced to condition (6.3) for the exponents  $a_{j,w}$  and  $c_{j,w}$  and the associated parameter  $k'$ .  $\square$

As before let  $G(w; h)$  denote the function on  $A_-$  corresponding to the vector  $e_w \in V$ ,  $w \in W$ . Using the results of Section 3 and 4 we can write

$$G(w; h) = \sum_{\gamma} G(w, \gamma; h) \tag{6.4}$$

with

$$G(w, \gamma; h) = \sum_{\nu \geq \mu_{w,\gamma}} \Gamma(w, \gamma, \nu) h^{\nu}. \tag{6.5}$$

Here  $\gamma$  runs over a complete set of representatives of the weight lattice  $P$  modulo the root lattice  $Q$ . The symbol  $\geq$  denotes the usual partial ordering on  $\mathfrak{h}^*$  relative to  $R_+$  (see 2.12) of [HO]). The exponents  $\mu_{w,\gamma} \in \mathfrak{h}^*$  are well defined if  $G(w, \gamma; h) \neq 0$  by taking them maximal relative to  $\geq$  and satisfy

$$\mu_{w,\gamma} - (w(\lambda + \gamma) + \varrho) \in Q. \tag{6.6}$$

The coefficients  $\Gamma(w, \gamma, \nu)$  are complex numbers, and the expansion (6.5) converges on  $A_-$ .

The boundary value of the function  $G(w, \gamma; h)$  along  $X(R_j)$  is the function

$$G_j(w, \gamma; h) = \sum_{\nu \geq \mu_{w,\gamma}, \nu \in \mu_{w,\gamma} + Q_j} \Gamma(w, \gamma, \nu) h^\nu \tag{6.7}$$

where  $Q_j$  denotes the root lattice of  $R_j$ .

**LEMMA 6.2:** *For  $\gamma$  a fixed representative for  $P$  modulo  $Q$  the space  $\mathbb{C}$ -span  $\{G(w, \gamma; h); w \in W\}$  is stable under the monodromy of the fundamental group  $\Pi_1(W \setminus H^{\text{reg}})$ . Moreover  $G(\gamma; h) = G(1, \gamma; h)$  is a cyclic vector for this representation.*

*Proof:* By induction the rank of  $R$ . For rank  $(R) = 1$  the statement follows easily from the theory of the Riemann  $P$ -function. For general  $R$  the lemma follows by applying the induction hypothesis to the boundary values.  $\square$

Denote by  $p_j: \mathfrak{h}^* \rightarrow \mathfrak{h}^*$  the orthogonal projection on the line  $\{\mu \in \mathfrak{h}^*; (\mu, \alpha_i) = 0 \forall i = 1, \dots, j - 1, j + 1, \dots, n\}$ . Let  $q_j: \mathfrak{h}^* \rightarrow \mathfrak{h}^*$  be defined by  $p_j + q_j = Id$ . The following lemma is elementary.

**LEMMA 6.3:** *Suppose rank  $(R) \geq 2$ . If  $\nu \in Q$  satisfies the condition  $q_j(\nu) \leq 0 \forall j = 1, \dots, n$ , then  $\nu \leq 0$ .*

*Proof:* Let  $\{v_1, \dots, v_n\}$  be a basis of  $\mathfrak{a}^*$  with  $(v_i, \alpha_j) = \delta_{ij}$ . Clearly  $q_j(\nu) = \nu - (v_j, v_j)^{-1}(v, v_j)v_j \forall \nu \in \mathfrak{h}^*$ . Hence  $q_j(\alpha_j) = \alpha_j - (v_j, v_j)^{-1}v_j = \sum_i (\delta_{ij} - 1)(v_j, v_j)^{-1}(v_i, v_j)\alpha_i$ . Suppose  $\nu = \sum k_i \alpha_i$ . Then  $q_j(\nu) = \sum_i \{k_i - k_j(v_j, v_j)^{-1}(v_i, v_j)\} \alpha_i$ . Suppose  $\nu \in Q$  satisfies  $q_j(\nu) \leq 0 \forall j = 1, \dots, n$ . Then  $k_i - k_j(v_j, v_j)^{-1}(v_i, v_j) \leq 0$ . Interchanging  $i$  and  $j$  and using that  $(v_j, v_j)^{-1}(v_i, v_j) \geq 0$  we also get  $k_j(v_j, v_j)^{-1}(v_i, v_j) - k_i(v_i, v_i)^{-1}(v_j, v_j)^{-1}(v_i, v_j)^2 \leq 0$ , and adding this to the previous inequality shows that  $k_i\{1 - (v_i, v_i)^{-1}(v_j, v_j)^{-1}(v_i, v_j)^2\} \leq 0$ . Using the Schwarz inequality we get  $k_i \leq 0$ .  $\square$

From now on fix  $\gamma \in P/Q$  such that  $G(\gamma; h) \neq 0$ .

**PROPOSITION 6.4:** Put  $v(G, \gamma) = \sum_{w \in W} (\mu_{w,\gamma} - \varrho(k))$ . Then we have  $v(G, \gamma) \leq 0$ .

*Proof:* By induction on the rank of  $R$ . For  $\text{rank}(R) = 1$  this amounts to the fact that for the Riemann  $P$ -function the sum of the exponents satisfies  $\alpha + \alpha' + \beta + \beta' + \gamma + \gamma' \leq 1$ . See Section 24 of [Kl]. In case  $\text{rank}(R) \geq 2$  we apply the induction hypothesis to the boundary values. Since the exponent of the boundary value  $G_j(w, \gamma; h)$  along  $X(R_j)$  is  $\geq q_j(\mu_{w,\gamma})$  the statement follows from the previous lemma.  $\square$

**PROPOSITION 6.5:** There exists a polynomial  $P(T) \in \mathbb{C}[T]$  such that  $P(L)G(\gamma; h) \equiv 0$ .

*Proof:* By induction on the rank of  $R$ . For  $\text{rank}(R) = 1$  this follows from the conclusion of Section 24 of [Kl]. Now suppose  $\text{rank}(R) \geq 2$ . Denote by  $L_j$  the differential operator

$$L_j = \sum_{i=1}^n \partial(X_i)^2 - \sum_{\alpha \in R_{j,+}} k_\alpha (1 + h^\alpha)(1 - h^\alpha)^{-1} \partial(X_\alpha).$$

Fix some  $j$ . By the induction hypothesis we have  $Q(L_j)G_j(\gamma; h) \equiv 0$  for some  $Q(T) \in \mathbb{C}[T]$ . If we put  $\tilde{G}(\gamma; h) = Q(L + 2(\mu_{1,\gamma}, p_j(\varrho)))G(\gamma; h)$ , then  $\tilde{G}(\gamma; h)$  is a Nilsson class function of the same type as  $G(\gamma; h)$ . However the exponents at infinity satisfy  $v(\tilde{G}, \gamma) > v(G, \gamma)$ . Repeating this procedure eventually the condition  $v(G, \gamma) \leq 0$  becomes violated. Hence  $P(L)G(\gamma; h) \equiv 0$  for some  $P(T) \in \mathbb{C}[T]$ .  $\square$

**THEOREM 6.6:** Let  $(\lambda, k) \in \mathfrak{h}^* \times K$  be an admissible parameter. Then there exists a Nilsson class function  $F(h)$  on  $W \setminus H^{\text{reg}}$  of monodromy type  $(V, M(\lambda, k), e_1)$  with the following properties. The functions  $F(w; h)$  corresponding to  $e_w \in V$  have on  $A_-$  expansions of the form

$$F(w; h) = \sum_{v \geq \mu_w} \Gamma(w, v) h^v. \tag{6.8}$$

The exponents  $\mu_w$  of  $F(w; h)$  satisfy

$$\mu_w - (w(\lambda + \gamma) + \varrho) \in Q \tag{6.9}$$

for some  $\gamma \in P$ . Moreover the function  $F(h)$  satisfies the differential equation

$$L(k)F(h) = cF(h) \tag{6.10}$$

for some  $c \in \mathbb{C}$ .

*Proof:* The proof follows immediately from the previous proposition.  $\square$

**7. The hypergeometric function associated to  $R$**

Let  $\phi(h)$  denotes a formal expansion on  $A_-$  of the form

$$\phi(h) = \sum_{v \geq \mu} \Gamma_v h^v. \tag{7.1}$$

Substituting  $\phi(h)$  in the differential equation

$$L(k)\phi = (\mu, \mu - 2\rho)\phi \tag{7.2}$$

and writing  $\Gamma_v = \Gamma_v(\mu, k)$  gives the ‘‘Freudenthal recurrence relations’’

$$\begin{aligned} & \{(\mu - \rho, \mu - \rho) - (v - \rho, v - \rho)\} \Gamma_v(\mu, k) \\ &= 2 \sum_{\alpha \in R_+} k_\alpha \sum_{j=1}^{\infty} (v - j\alpha, \alpha) \Gamma_{v-j\alpha}(\mu, k). \end{aligned} \tag{7.3}$$

Under the condition  $(\mu - \rho, \kappa^v) + 1 \neq 0$  for all  $\kappa \in Q, \kappa > 0$  these recurrence relations can be uniquely solved up to a choice of the leading coefficient  $\Gamma_\mu(\mu, k)$ . With the choice  $\Gamma_\mu(\mu, k) = 1$  we denote the corresponding expansion (7.1) by  $\phi(\mu, k; h)$ .

**DEFINITION 7.1:** The vector  $\lambda \in \mathfrak{h}^*$  is called generic if

$$(\lambda + \kappa_1, \lambda + \kappa_1) \neq (\lambda + \kappa_2, \lambda + \kappa_2) \quad \forall \kappa_1, \kappa_2 \in Q, \quad \kappa_1 \neq \kappa_2.$$

**LEMMA 7.2:** *Suppose a non trivial expansion of the form (7.1), with  $\mu - \rho$  generic, satisfies the differential equation  $L\phi = c\phi$  for some  $c \in \mathbb{C}$ . Then  $c = (v, v - 2\rho)$  for some  $v \geq \mu$ , and  $\phi(h) = \Gamma_v \phi(v, k; h)$ .*

*Proof:* If  $v$  is a minimal element of  $\{v \geq \mu; \Gamma_v \neq 0\}$  relative to the partial ordering  $\leq$ , then  $c = (v, v - 2\rho)$ . Since  $\mu - \rho$  is generic, it follows that the minimal element  $v$  is unique. □

**PROPOSITION 7.3:** *Suppose  $\lambda \in \mathfrak{h}^*$  with  $\lambda + \gamma$  generic  $\forall \gamma \in P$ . Suppose  $k \in K$  is admissible. In the notation of Theorem 6.6 there exists  $\lambda' \in \mathfrak{h}^*$  with  $\lambda' - \lambda \in P$  such that*

$$\mu_w = w\lambda' + \rho. \tag{7.4}$$



The constant  $c \in \mathbb{C}$  in (6.10) is given by  $c = (\lambda' - \varrho, \lambda' + \varrho)$ . Moreover, after a suitable normalization we have  $F(w; h) = \phi(w\lambda' + \varrho, k; h)$ , and the function

$$F(\lambda', k; h) = \sum_{w \in W} c(w\lambda', k)\phi(w\lambda' + \varrho, k; h) \tag{7.5}$$

extends from  $A_-$  to a Weyl group invariant analytic function on  $A$ .

*Proof:* The expansion (6.8) satisfies the differential equation (6.10). Hence applying Lemma 7.2 we get  $c = (v_w, v_w - 2\varrho)$  and  $F(w; h) = \Gamma_w \phi(v_w, k; h)$  for some  $v_w \geq \mu_w$ , and  $\Gamma_w \in \mathbb{C}$ . Put  $\lambda' = v_1 - \varrho$ . Then  $v_w - (w\lambda' + \varrho) \in Q$ , and since  $\lambda'$  is generic we conclude  $v_w = w\lambda' + \varrho$ , moreover we have  $F(w; h) = \Gamma_w \phi(w\lambda' + \varrho, k; h)$  for some  $\Gamma_w \in \mathbb{C}$ . By induction on the rank we get  $\Gamma_w = \Gamma_v \forall w, v \in W$ , and after suitable normalization we get  $\Gamma_w = 1 \forall w \in W$ . An easy computation shows that  $F(\lambda', k; h)$  is fixed under the monodromy of the curves  $s_j, j = 1, \dots, n$ . Since the exponents along the discriminant satisfy condition (6.3) the proposition follows.  $\square$

**DEFINITION 7.4:** Considered as a  $W$ -invariant analytic function on  $A$  the function  $F(\lambda', k; h)$  of the previous proposition is called the hypergeometric function associated to the root system  $R$  with parameters  $(\lambda', k)$ .

From now on we assume that  $k \in K$  is a fixed admissible parameter, which will be suppressed in the notation. for  $\mu \in P_-$  we write

$$z(\mu) = \sum_{w \in W/W^\mu} h^{w\mu} \tag{7.6}$$

for the corresponding invariant Fourier polynomial on  $H$ . Assume  $\lambda \in \mathfrak{h}^*$  such that  $\lambda + \gamma$  is generic for all  $\gamma \in P$ . Formally we can write

$$z(\mu)\phi(\lambda + \varrho; h) = \sum_{\nu \geq \lambda + \mu} d(\mu, \lambda, \nu)\phi(\nu + \varrho; h). \tag{7.7}$$

For  $\mu \in P_-$ , and  $\kappa \geq 0$  fixed the map  $\lambda \mapsto d(\mu, \lambda, \lambda + \mu + \kappa)$  is a rational function, due to the fact that the coefficients in the expansion of  $\phi(\lambda + \varrho; h)$  are rational functions of  $\lambda$ . Clearly  $d(\mu, \lambda, \lambda + \mu) = 1$ .

**THEOREM 7.5:** Suppose  $k \in K$  is admissible. Suppose  $\lambda \in \mathfrak{h}^*$  satisfies  $\lambda + \gamma$  generic for all  $\gamma \in P$ . Via the map  $e_w \mapsto \phi(w\lambda + \varrho, k; h)$  the functions  $\mathbb{C}$ -span  $\{\phi(w\lambda + \varrho, k; h); w \in W\}$  define a system of Nilsson class functions on  $W \setminus H^{\text{reg}}$  of monodromy type  $M(\lambda, k)$ . The function  $F(\lambda, k; h) = \sum_{w \in W} c(w\lambda, k)\phi(w\lambda + \varrho, k; h)$  extends from  $A_-$  to a Weyl group invariant analytic function on all of  $A$ .

*Proof:* By Proposition 7.3 it remains to show that if the theorem holds for a given  $\lambda \in \mathfrak{h}^*$ , then it also holds for all parameters contiguous with  $\lambda$ . For this purpose consider for  $\mu \in P_-$  the function  $z(\mu)F(\lambda, k; h)$ . Clearly it is analytic and Weyl group invariant on all of  $A$ . Using (7.7) we can write

$$\begin{aligned} z(\mu)F(\lambda, k; h) &= \sum_{w \in W} c(w\lambda) \sum_{v \geq \mu} d(\mu, w\lambda, w\lambda + v)\phi(w\lambda + v + \varrho; h) \\ &= \sum_{w \in W} \sum_v c(w\lambda)d(\mu, w\lambda, w(\lambda + v))\phi(w(\lambda + v) + \varrho, h) \end{aligned}$$

In order to separate terms according to different eigenvalues of  $L$  the terms  $\{\phi(w(\lambda + v) + \varrho, h); w \in W\}$  should be taken together. Moreover their coefficients  $c(w\lambda)d(\mu, w\lambda, w(\lambda + v))$  should be proportional with  $c(w(\lambda + v))$ . The conclusion is that

$$\frac{c(w\lambda)d(\mu, w\lambda, w(\lambda + v))}{c(w(\lambda + v))}$$

is independent of  $w$ , and also

$$z(\mu)F(\lambda, k; h) = \sum_v \frac{c(w\lambda)d(\mu, w\lambda, w(\lambda + v))}{c(w(\lambda + v))} F(\lambda + v, k; h)$$

and the theorem follows. □

From the proof we also get the following result.

**COROLLARY 7.6:** *The coefficients  $d(\mu, \lambda, v)$  in (7.7) satisfy*

$$d(\mu, \lambda, \lambda + v) = \frac{c(w\lambda)c(\lambda + v)}{c(w(\lambda + v))c(\lambda)} d(\mu, w\lambda, w(\lambda + v)). \tag{7.8}$$

*In particular  $d(\mu, \lambda, \lambda + v) = 0$  unless  $v \in C(\mu)$ . Here we write*

$$C(\mu) = \{v; wv \geq \mu \ \forall w \in W\} \tag{7.9}$$

*for the integral convex hull of  $W \cdot \mu, \mu \in P_-$ .*

**COROLLARY 7.7:** *The coefficients  $d(\mu, \lambda, \lambda + w\mu)$  are given by*

$$d(\mu, \lambda, \lambda + w\mu) = \frac{c(w^{-1}\lambda)c(\lambda + w\mu)}{c(w^{-1}\lambda + \mu)c(\lambda)}. \tag{7.10}$$

**8. Jacobi polynomials associated to  $R$**

In this section we assume that the parameter  $k \in K$  satisfies  $k_\alpha \in \mathbb{R}_+$  for all  $\alpha \in R$ . Denote by  $\mathbb{C}[H]^W$  the vector space of Weyl group invariant exponential polynomials on  $H$ . Define a hermitean inner product on  $\mathbb{C}[H]^W$  by

$$(f, g) = \int_T f(t) \overline{g(t)} \delta(k, t) dt \tag{8.1}$$

where  $T$  is the compact form of  $H$ , and  $dt$  the normalized Haar measure on  $T$ . As shown in Section 2 of [HO] the operator  $L$  leaves the space  $\mathbb{C}[H]^W$  invariant, and is symmetric with respect to the inner product (6.1). The following proposition is immediate.

**PROPOSITION 8.1:** *For a Weyl group invariant exponential polynomial of the form*

$$P(\mu, k; h) = \sum_{\nu \in C(\mu)} \Gamma_\nu(\mu, k) h^\nu \tag{8.2}$$

with

$$\mu \in P_-, \Gamma_\mu(\mu, k) = 1, \Gamma_{w\nu}(\mu, k) = \Gamma_\nu(\mu, k) \quad \forall w \in W$$

the conditions

$$L(k)P(\mu, k; h) = (\mu, \mu - 2\rho)P(\mu, k; h) \tag{8.3}$$

and

$$\Gamma_\nu(\mu, k) \text{ satisfies the recurrence relations (7.3)} \tag{8.4}$$

and

$$(P(\mu, k; h), P(\nu, k; h)) = 0 \quad \forall \nu \in P_-, \nu > \mu \tag{8.5}$$

are all three equivalent.

**DEFINITION 8.2:** The function  $P(\mu, k; h)$  of the previous proposition is called the Jacobi polynomial associated to  $R$  with lowest weight  $\mu \in P_-$  and parameter  $k \in K$ .

**THEOREM 8.3:** *The Jacobi polynomials  $P(\mu, k; h), \mu \in P_-$  satisfy the orthogonality relations*

$$(P(\mu, k; h), P(\nu, k; h)) = 0 \text{ for } \mu, \nu \in P_-, \mu \neq \nu. \tag{8.6}$$

*Proof:* The proof follows from Corollary 7.6 and the next proposition.  $\square$

**PROPOSITION 8.4:** *The orthogonality relations (8.6) are equivalent with the conditions*

$$P(\mu, k; h)P(\nu, k; h) = \sum_{\mu + \nu \leq \kappa \leq w_0\mu + \nu} e(\mu, \nu, \kappa)P(\kappa, k; h) \tag{8.7}$$

for certain coefficients  $e(\mu, \nu, \kappa)$ . Here  $w_0$  is the longest element in the Weyl group.

*Proof:* Suppose we know the orthogonality relations (8.6). Then the coefficient  $e(\mu, \nu, \kappa)$  is given by

$$e(\mu, \nu, \kappa) = (P(\kappa), P(\kappa))^{-1}(P(\mu)P(\nu), P(\kappa)).$$

It is trivial that  $e(\mu, \nu, \kappa) = 0$  unless  $\kappa \geq \mu + \nu$ . Since  $(P(\mu)P(\nu), P(\kappa)) = (P(\nu), P(\bar{\mu})P(\kappa))$  with  $\bar{\mu} = -w_0\mu$  we see that  $e(\mu, \nu, \kappa) = 0$  unless  $\nu \geq \bar{\mu} + \kappa$ . The latter condition is the same as  $\kappa \leq w_0\mu + \nu$ . Conversely, suppose we know the relation (8.7). By Proposition 8.1 we know that  $P(0) \equiv 1$  orthogonal to  $P(\mu)$  for all  $\mu \in P_-, \mu \neq 0$  (using the Freudenthal inequality  $(\mu - \varrho, \mu - \varrho) > (\varrho, \varrho)$  for all  $\mu \in P_-, \mu \neq 0$ ). Hence  $(P(\mu), P(\nu)) \neq 0 \Leftrightarrow e(\mu, \bar{\nu}, 0) \neq 0 \Rightarrow 0 \leq w_0\mu + \bar{\nu} \Leftrightarrow w_0\nu \leq w_0\mu \Leftrightarrow \mu \leq \nu$ . But the condition  $(P(\mu), P(\nu)) \neq 0$  is symmetric in  $\mu$  and  $\nu$ . Hence  $(P(\mu), P(\nu)) \neq 0$  implies both  $\mu \leq \nu$  and  $\nu \leq \mu$ , i.e.  $\mu = \nu$ .  $\square$

**THEOREM 8.5:** *The  $L_2$ -norm of the polynomials  $F(\mu - \varrho, k; t) = c(\mu - \varrho, k)P(\mu, k; t)$  for  $\mu \in P_-$  relative to the inner product (8.1) is given by*

$$(F(\mu - \varrho, k; t), F(\nu - \varrho, k; t)) = d(\mu, k)^{-1} \int_T \delta(k, t) dt \tag{8.8}$$

where

$$d(\mu, k) = \lim_{\varepsilon \rightarrow 0} \frac{c(-\varrho)c(\varrho + \varepsilon)}{c(\mu - \varrho)c(-\mu + \varrho + \varepsilon)} \tag{8.9}$$

*Proof:* Using Theorem (8.3) it follows that for  $\mu \in P_- (P(\mu), P(\mu)) = e(\mu, \bar{\mu}, 0) \int_T \delta(k, t) dt$  in the notation of (8.7) and  $\bar{\mu} = -w_0\mu$ . Using Corollary 7.7

with  $w = w_0$  gives

$$\begin{aligned}
 e(\mu, \bar{\mu}, 0) &= \lim_{\lambda \rightarrow -\varrho - w_0\mu} d(\mu, \lambda, \lambda + w_0\mu) \\
 &= \lim_{\lambda \rightarrow -\varrho - w_0\mu} \frac{c(w_0^{-1}\lambda)c(\lambda + w_0\mu)}{c(w_0^{-1}\lambda + \mu)c(\lambda)} \\
 &= \lim_{\varepsilon \rightarrow 0} \frac{c(-\mu + \varrho + \varepsilon)c(-\varrho + w_0\varepsilon)}{c(\varrho + \varepsilon)c(\bar{\mu} - \varrho + w_0\varepsilon)}.
 \end{aligned}$$

Here we have also used that  $w_0\varrho = -\varrho$ . It turns out that the limits  $c(-\varrho)$  and  $c(\bar{\mu} - \varrho)$  are well defined. Using  $F(\mu - \varrho) = c(\mu - \varrho)P(\mu)$  we get the formula

$$(F(\mu - \varrho), F(\mu - \varrho)) = \lim_{\varepsilon \rightarrow 0} \frac{c(-\mu + \varrho + \varepsilon)c(\mu - \varrho)}{c(\varrho + \varepsilon)c(-\varrho)} \int_T \delta(k, t) dt$$

in view of the normalization  $c(-\varrho) = 1$ . □

REMARK 8.6: An explicit formula for  $\int_T \delta(k, t) dt$  has been conjectured by Macdonald [M]. For type  $BC_2$  the square integrable norm of  $P(\mu)$  has been computed by Sprinkhuizen–Kuyper [S]. Now suppose that the parameter  $k \in K$  corresponds to a symmetric space. Then it is known that  $F(\mu - \varrho, k; e) = 1 \forall \mu \in P_-$ . By the Schur orthogonality relations it follows that  $d(\mu, k)$  is equal to the dimension of the spherical representation associated to  $\mu \in P_-$ . Hence formula (8.9) can be viewed as an explicit formula for the dimension of a finite dimensional spherical representation in terms of data of the restricted root system. For a symmetric space formulas (8.8) and (8.9) were derived by Vetrare [V].

**References**

[D] P. Deligne, *Équations Différentielles à Points Singuliers Réguliers*, LNM 163, Springer Verlag (1970).  
 [HO] G.J. Heckman and E.M. Opdam, Root systems and hypergeometric functions I, *Comp. Math.* 64 (1987) 329–352.  
 [Kl] F. Klein, *Vorlesungen über die Hypergeometrische Funktion*, Grundle. Math. Wissenschaften, Springer (1933).  
 [KO] M. Kashiwara and T. Oshima, Systems of differential equations with regular singularities and their boundary value problems, *Ann of Math.* 106 (1977) 154–200.  
 [vdL] H. v.d. Lek, The homotopy type of complex hyperplane complements, Thesis, Nijmegen (1983).

- [M] I.G. Macdonald, Some conjectures for root systems, *Siam J. Math. Anal.* 13(6) (1982) 988–1007.
- [Op] E.M. Opdam, Root systems and hypergeometric functions III, to appear in *Comp. Math.*
- [Os] T. Oshima, A Definition of Boundary Values of Solutions of Partial Differential Equations with Regular Singularities, *Publ. RIMS, Kyoto Univ* 19 (1983) 1203–1230.
- [P] J. Plemelj, *Problems in the Sense of Riemann and Klein*, Interscience Publ. (1964).
- [R] B. Riemann, Beiträge zur Theorie der durch die Gauss'sche Reihe  $F(\alpha, \beta, \gamma; x)$  darstellbaren Funktionen, *Ges. Abh.*, 67–87 (1857).
- [S] I.G. Sprinkhuizen-Kuiper, Orthogonal polynomials in 2 variables. A further analysis of the polynomials orthogonal over a region bounded by two lines and a parabola. *Siam J. Math. Anal.* 7(4) (1976) 501–518.
- [WW] E.T. Whittaker and G.T. Watson, *A Course in Modern Analysis*, Cambr. Univ. Press (1927).