

Astérisque

JEAN-MICHEL BISMUT

Holomorphic families of immersions and higher analytic torsion forms

Astérisque, tome 244 (1997)

http://www.numdam.org/item?id=AST_1997__244__R1_0

© Société mathématique de France, 1997, tous droits réservés.

L'accès aux archives de la collection « Astérisque » (<http://smf4.emath.fr/Publications/Asterisque/>) implique l'accord avec les conditions générales d'utilisation (<http://www.numdam.org/conditions>). Toute utilisation commerciale ou impression systématique est constitutive d'une infraction pénale. Toute copie ou impression de ce fichier doit contenir la présente mention de copyright.

NUMDAM

Article numérisé dans le cadre du programme
Numérisation de documents anciens mathématiques

<http://www.numdam.org/>

244

ASTÉRISQUE

1997

**HOLOMORPHIC FAMILIES
OF IMMERSIONS AND HIGHER
ANALYTIC TORSION FORMS**

Jean-Michel BISMUT

SOCIÉTÉ MATHÉMATIQUE DE FRANCE

Publié avec le concours du CENTRE NATIONAL DE LA RECHERCHE SCIENTIFIQUE

L'auteur remercie l'Institut Universitaire de France (I. U. F.) pour son soutien. Une partie de ce travail a été effectuée à l'Institute for Advanced Study (I. A. S.) de Princeton, de Janvier à Mars 1994, grâce au soutien de la fondation Gould, que l'auteur remercie très vivement. L'auteur remercie également un rapporteur pour ses observations sur ce texte.

Contents

Introduction	1
1 Families of immersions and connections on the relative tangent bundle	13
1.1 A canonical connection on the relative tangent bundle of a fibration	13
1.2 An identity on the connection on the relative tangent bundle	15
1.3 Families of immersions and the corresponding connections on the relative tangent bundles	16
2 Kähler fibrations, higher analytic torsion forms and anomaly formulas	23
2.1 Kähler fibrations	23
2.2 Complex Hermitian vector spaces and Clifford algebras	26
2.3 The Levi-Civita superconnection of the fibration	27
2.4 Superconnection forms and transgression formulas	29
2.5 The asymptotics of the superconnection forms as $u \rightarrow 0$	30
2.6 The asymptotics of the superconnection forms as $u \rightarrow +\infty$	31
2.7 Higher analytic torsion forms	32
2.8 Anomaly formulas for the analytic torsion forms	33
3 Kähler fibrations, resolutions, and Bott-Chern currents	35
3.1 A family of double complexes	35
3.2 The analytic torsion forms of the double complex	37
3.3 Assumptions on the metrics on ξ, η	40
3.4 A Bott-Chern current	41
4 An identity on two parameters differential forms	43
4.1 A basic identity of differential forms	43
4.2 A change of coordinates	46

4.3	A contour integral	47
4.4	Some elementary identities	48
5	The analytic torsion forms of a short exact sequence	51
5.1	Short exact sequences and superconnections	51
5.2	The conjugate superconnections \mathcal{C}_u and \mathcal{D}_u	54
5.3	Generalized supertraces	55
5.4	Transgression formulas and convergence of generalized supertraces	56
5.5	Generalized analytic torsion forms	56
5.6	Evaluation of the generalized analytic torsion forms	57
5.7	Equivariant generalized analytic torsion forms	58
5.8	Some identities on generalized supertraces	60
5.9	A conjugation formula	67
6	A proof of Theorem 0.1	69
6.1	The main Theorem	70
6.2	A rescaled metric on E	71
6.3	The left-hand side of (4.26): seven intermediate results	72
6.4	The asymptotics of the I_k^0 's	74
	The term I_1^0	75
	The term I_2^0	77
	The term I_3^0	79
	The term I_4^0	80
6.5	The divergences of the left-hand side of (4.26)	83
6.6	The right-hand side of (4.26): five intermediate results	84
6.7	The asymptotics of the right-hand side of (4.26)	88
6.8	Matching the divergences	105
6.9	An identity on Bott-Chern classes and Bott-Chern currents	107
6.10	Proof of Theorem 6.2	108
7	A new horizontal bundle on V and the conjugate superconnection	109
	$\tilde{A}_{u,T}$	
7.1	A formula for D^X and D^Y	110
7.2	The canonical exact sequence on W	110
7.3	A coordinate system on V near W	111
7.4	A splitting of ξ near W	111
7.5	A cohomological obstruction to the equality $T^H V _W = T^H W$	113
7.6	An extension of $T^H W$ to V	114

7.7	The conjugate superconnection $\tilde{A}_{u,T}$	116
7.8	A Lichnerowicz formula for $A_{u,T}^2$ and $\tilde{A}_{u,T}^2$	118
8	A Taylor expansion of the superconnection $\tilde{A}_{1,T}$ near W	121
8.1	A trivialization of $\Lambda(T^{*(0,1)}X) \hat{\otimes} \xi$ along geodesics normal to Y	121
8.2	A Taylor expansion for $\tilde{A}_{1,T}$ near W	122
8.3	The projection of the superconnection \mathfrak{B}	128
9	The asymptotics of supertraces involving the operator $\exp(-B_{u,T}^2)$ for large values of u, T	131
9.1	The spectrum of $B_{u,T}^2$	133
9.2	A scaling formula	134
9.3	Two intermediate results	135
9.4	A formula for $P^{\xi^-} f^\alpha \nabla_{f_{H,W}^\alpha}^\xi V P^{\xi^-} _W$ and its normal derivative	137
9.5	An embedding of F in \tilde{E}	138
9.6	A Sobolev norm on E^1	140
9.7	Estimates on the resolvent of \tilde{A}_T^2	144
9.8	Regularizing properties of the resolvent of \tilde{A}_T^2	146
9.9	Uniform estimates on the kernel $F_u(\tilde{A}_T^2)$	150
9.10	The matrix structure of \tilde{A}_T^2 as $T \rightarrow +\infty$	153
9.11	The asymptotics of the operator $F_u(\tilde{A}_T^2)$ as $T \rightarrow +\infty$	155
9.12	Proof of Theorem 9.5	155
9.13	The operators $\mathcal{G}_{a,b,c,T}$	157
9.14	Proof of Theorem 9.6	160
9.15	Proof of Theorem 6.15	162
9.16	Proof of Theorem 6.16	163
10	The asymptotics of the metric $g_T^{H(Y,\eta Y)}$ as $T \rightarrow +\infty$	165
10.1	The lift of sections of $\ker D^Y$ to sections of $\ker A_T^{(0)}$	165
10.2	The lift of sections of $\ker D^Y$ to harmonic forms in E for	171
10.3	Proof of Theorem 6.10	174
11	The analysis of the two parameter semi-group $\exp(-A_{u,T}^2)$ in the range $u \in]0, 1]$, $T \in [0, \frac{1}{u}]$	177
11.1	The limit as $u \rightarrow 0$ of $\Phi \text{Tr}_s [N_{\mathbf{H}} \exp(-A_{u,T}^2)]$	178
11.2	Localization of the problem	179
11.3	A rescaling of the normal coordinate Z_0	182
11.4	A local coordinate system near W and a trivialization of $\pi_V^* \Lambda(T_{\mathbf{R}}^* S) \hat{\otimes} \Lambda(T^{*(0,1)}X) \hat{\otimes} \xi$	182

11.5	The Taylor expansion of the operator $\widetilde{B}_{u^2}^{V,2}$	185
11.6	Replacing X by $(T_{\mathbf{R}}X)_{y_0}$	186
11.7	Rescaling of the variable Z and of the Clifford variables	187
11.8	The matrix structure of $L_{u,T}^{3,Z_0/T}$	190
11.9	A family of Sobolev spaces with weights	192
11.10	Proof of Theorem 11.5	193
11.11	Proof of Theorem 6.17	193
12	The analysis of the kernel of $\widetilde{F}_u(A_{u,T/u}^2)$ for $T > 0$ as $u \rightarrow 0$	195
12.1	Localization of the problem	196
12.2	A local coordinate system near $y_0 \in W$ and a trivialization of $\Lambda(T^{*(0,1)}X) \widehat{\otimes} \xi$	196
12.3	Replacing the fibre X by $(T_{\mathbf{R}}X)_{y_0}$	196
12.4	Rescaling of the variable Z and of the horizontal Clifford variables	197
12.5	The asymptotics of the operator $L_{u,T/u}^{3,y_0}$ as $u \rightarrow 0$	198
12.6	Proof of Theorem 6.8	203
12.7	Proof of the first half of Theorem 6.18	203
13	The analysis of the two parameter operator $\exp(-A_{u,T}^2)$ in the range $u \in]0, 1]$, $T \geq 1/u$	213
13.1	A proof of Theorem 6.9: the problem is localizable on W	214
13.2	An orthogonal splitting of TX and a connection on TX	216
13.3	A local coordinate system near $y_0 \in W$ and a trivialization	217
13.4	Replacing X by $(T_{\mathbf{R}}X)_{y_0}$	219
13.5	Rescaling of Z and of the horizontal Clifford variables	220
13.6	A formula for $\mathcal{L}_{u,T}^{3,y_0}$	222
13.7	The algebraic structure of the operator $\mathcal{L}_{u,T}^{3,y_0}$ as $u \rightarrow 0$	225
13.8	The matrix structure of the operator $\mathcal{L}_{u,T}^{3,y_0}$ as $T \rightarrow +\infty$	229
13.9	The asymptotics of $F_T k^{1/2} \widetilde{A}_{1,T} k^{-1/2} F_T^{-1}$	232
13.10	A family of Sobolev spaces with weights	235
13.11	The operator Ξ_{y_0}	236
13.12	Proof of Theorem 13.2	237
13.13	A proof of Theorem 6.19	237
	An evaluation of the limit of $\theta_{u,T}$ as $T \rightarrow +\infty$	237
	The connection ${}^3\nabla^{\pi^* \Lambda(T_{\mathbf{R}}^* S) \widehat{\otimes} \Lambda(\mathbf{R}^{2^*}) \widehat{\otimes} \Lambda(T^{*(0,1)} X)}$	246
	The algebraic structure of $\mathcal{L}_{u,T}^{3,y_0}$ as $u \rightarrow 0$	247
	An estimate on $ \theta_{u,T/u} - \theta_u^* $	250
13.14	A proof of the second half of Theorem 6.18	251

14 A proof of Theorem 0.2	259
14.1 A closed form on $\mathbf{R}_+^* \times \mathbf{R}_+^*$	259
14.2 The asymptotics of the $I_k^{\prime 0}$'s	260
The term $I_1^{\prime 0}$	260
The term $I_2^{\prime 0}$	262
The term $I_3^{\prime 0}$	264
The term $I_4^{\prime 0}$	264
The right-hand side of (14.6)	265
14.3 Matching the divergences	266
14.4 Proof of Theorem 0.2	266
15 A new derivation of the asymptotics of the generalized supertraces associated to a short exact sequence	267
15.1 A family of immersions	268
15.2 The superconnection \mathcal{B}_T	269
Bibliography	273

Introduction

Let $i: W \rightarrow V$ be an embedding of smooth complex manifolds. Let S be a complex manifold. Let $\pi_V: V \rightarrow S$ be a holomorphic submersion with compact fibre X , which restricts to a holomorphic submersion $\pi_W: W \rightarrow S$, with compact fibre Y . Then we have the diagram of holomorphic maps

$$(0.1) \quad \begin{array}{ccccc} Y & \longrightarrow & W & & \\ \downarrow i & & \downarrow i & \searrow \pi_W & \\ X & \longrightarrow & V & \xrightarrow{\pi_V} & S \end{array}$$

Let η be a holomorphic vector bundle on W . Let (ξ, ν) be a holomorphic complex of vector bundles on V , which together with a holomorphic restriction maps $r: \xi_{0|W} \rightarrow \eta$, provides a resolution of the sheaf $i_*\eta$.

Let $R\pi_{V*}\xi, R\pi_{W*}\eta$ be the direct images of ξ, η . We make the assumption that the $R^i\pi_{W*}\eta$ are locally free. Then $R\pi_{V*}\xi$ is also locally free, and moreover we have a canonical isomorphism of \mathbf{Z} -graded holomorphic vector bundles on S

$$(0.2) \quad R\pi_{V*}\xi \simeq R\pi_{W*}\eta.$$

Also for any $s \in S$,

$$(0.3) \quad \begin{aligned} (R\pi_{V*}\xi)_s &\simeq H(X_s, \xi|_{X_s}), \\ (R\pi_{W*}\eta)_s &\simeq H(Y_s, \eta|_{Y_s}) \end{aligned}$$

(here $H(X_s, \xi|_{X_s})$ and $H(Y_s, \eta|_{Y_s})$ denote respectively the hypercohomology of $\xi|_{X_s}$, and the cohomology of $\eta|_{Y_s}$).

Let ω^V, ω^W be real (1,1) forms on V, W which are closed, and which, when restricted to the relative tangent bundles TX, TY , are the Kähler forms of Hermitian metrics g^{TX}, g^{TY} on TX, TY . Let $g^{\xi_0}, \dots, g^{\xi_m}, g^\eta$ be Hermitian metrics on $\xi_0, \dots, \xi_m, \eta$.

Let $(\Omega(Y, \eta|_Y), \bar{\partial}^Y)$ be the family of relative Dolbeault complexes along the fibres Y , whose cohomology is equal to $H(Y, \eta|_Y)$.

Let $\text{Td}(TY, g^{TY})$ be the Todd form in Chern-Weil theory which is associated to the holomorphic Hermitian connection ∇^{TY} on (TY, g^{TY}) . Other Chern-Weil forms will be denoted in a similar way. In particular $\text{ch}(\eta, g^\eta)$ denotes the Chern character form of the Hermitian holomorphic vector bundle (η, g^η) .

Let P^S be the vector space of smooth real differential forms on S which are sums of forms of type (p, p) . Let P_0^S be the subspace of the $\alpha \in P^S$, such that there exist smooth forms β and γ on S , with $\alpha = \bar{\partial}\beta + \partial\gamma$.

By identifying $H(Y, \eta|_Y)$ to the corresponding fibrewise harmonic forms in $\Omega(Y, \eta|_Y)$, the \mathbf{Z} -graded vector bundle $H(Y, \eta|_Y)$ is naturally equipped with a L_2 metric, whose unambiguous normalization is given in equations (2.22), (2.23).

Let $T(\omega^W, g^\eta)$ be the form in P^S constructed by Bismut-Gillet-Soulé [14] and Bismut-Köhler [18], using Quillen's superconnections [32], such that

$$(0.4) \quad \frac{\bar{\partial}\partial}{2i\pi} T(\omega^W, g^\eta) = \text{ch}(H(Y, \eta|_Y), g^{H(Y, \eta|_Y)}) - \int_Y \text{Td}(TY, g^{TY}) \text{ch}(\eta, g^\eta).$$

The forms $T(\omega^W, g^\eta)$ are called higher analytic torsion forms. The component of degree 0 of $T(\omega^W, g^\eta)$ coincides with the Ray-Singer analytic torsion of the relative Dolbeault complex [34], which is used to define the corresponding Quillen metrics [33], [13], [15] on $\det R\pi_{W*}\eta$. By the same procedure, for $0 \leq i \leq m$, we can construct forms $T(\omega^V, g^{\xi^i})$ ($0 \leq i \leq m$) in P^S .

Let $(\Omega(X, \xi|_X), \bar{\partial}^X + v)$ be the family of relative Dolbeault double complexes, whose cohomology coincides with the hypercohomology $H(X, \xi|_X)$. Let $g^{H(X, \xi|_X)}$ be the corresponding L_2 metric on $H(X, \xi|_X)$. Put $\text{ch}(\xi, g^\xi) = \sum_{i=0}^m (-1)^i \text{ch}(\xi_i, g^{\xi^i})$. By the same procedure as in [14], [18], we construct in Section 3.2 analytic torsion forms $T(\omega^V, g^\xi) \in P^S$, such that

$$(0.5) \quad \frac{\bar{\partial}\partial}{2i\pi} T(\omega^V, g^\xi) = \text{ch}(H(X, \xi|_X), g^{H(X, \xi|_X)}) - \int_X \text{Td}(TX, g^{TX}) \text{ch}(\xi, g^\xi).$$

An important property of these analytic torsion forms is that, as shown in [18, Theorem 3.10 and 3.11], their variations in $P^S/P^{S,0}$ with respect to (ω^W, g^η) or (ω^V, g^{ξ^i}) is expressed in terms of the Bott-Chern classes [13] of the corresponding holomorphic Hermitian vector bundles. These Bott-Chern classes are secondary invariants of Hermitian vector bundles, one can think of as complex analogues of Chern-Simons classes. In particular, it follows from [18, Theorem 3.11] that the classes of the analytic torsion forms in $P^S/P^{S,0}$ only depend on ω^V, ω^W through g^{TX}, g^{TY} . Note that in degree 0, these anomaly formulas of [18] specialize to the anomaly formulas for Quillen metrics established in [15].

Before we proceed, we make certain restrictions on the various metrics. By identifying the normal bundles $N_{W/V} \simeq N_{Y/X}$ to the orthogonal bundle to TY in

$TX|_Y$, $N_{Y/X}$ inherits a metric $g^{N_{Y/X}}$. We will assume that the metrics $g^{\xi_0}, \dots, g^{\xi_m}$ verify assumption (A) of [5, Definition 1.5], with respect to $g^{N_{Y/X}}, g^\eta$. This assumption is a compatibility assumption on the metrics $g^{\xi_0}, \dots, g^{\xi_m}$ to the metrics $g^\eta, g^{N_{Y/X}}$, which is briefly described in Section 3.3. By [5, Proposition 1.6], one can always find metrics $g^{\xi_0}, \dots, g^{\xi_m}$ verifying (A). Let P_W^V be the vector space of sums of real (p, p) currents on V , whose wave front set is included in $N_{W/V, \mathbf{R}}^*$. Let $P_W^{V,0}$ be the obvious analogue of $P^{S,0}$.

Let $T(\xi, g^\xi) \in P_W^V$ be the Bott-Chern current of [16] such that

$$(0.6) \quad \frac{\bar{\partial}\partial}{2i\pi} T(\xi, g^\xi) = \text{Td}^{-1}(N_{Y/X}, g^{N_{Y/X}}) \text{ch}(\eta, g^\eta) \delta_{\{W\}} - \text{ch}(\xi, g^\xi).$$

By [17], the dependence of the class of $T(\xi, g^\xi)$ in $P_W^V/P_W^{V,0}$ can be described in terms of Bott-Chern classes. Since $T(\xi, g^\xi) \in P_W^V$, by [30, Theorem 8.2.12], $\int_X \text{Td}(TX, g^{TX}) T(\xi, g^\xi) \in P^S$.

Let $\widetilde{\text{Td}}(TY, TX|_W, g^{TX|_W}) \in P^W/P^{W,0}$ be the Bott-Chern class of [13], such that

$$(0.7) \quad \frac{\bar{\partial}\partial}{2i\pi} \widetilde{\text{Td}}(TY, TX|_W, g^{TX|_W}) = \text{Td}(TX|_W, g^{TX|_W}) - \text{Td}(TY, g^{TY}) \text{Td}(N_{Y/X}, g^{N_{Y/X}}).$$

Since $H(X, \xi|_X) \simeq H(Y, \eta|_Y), g^{H(X, \xi|_X)}$ and $g^{H(Y, \eta|_Y)}$ can be considered as metrics on the same vector bundle. Let $\widetilde{\text{ch}}(H(X, \xi|_X), g^{H(X, \xi|_X)}, g^{H(Y, \eta|_Y)}) \in P^S/P^{S,0}$ be the Bott-Chern class of [13] such that

$$(0.8) \quad \frac{\bar{\partial}\partial}{2i\pi} \widetilde{\text{ch}}(H(Y, \eta|_Y), g^{H(X, \xi|_X)}, g^{H(Y, \eta|_Y)}) = \text{ch}(H(Y, \eta|_Y), g^{H(Y, \eta|_Y)}) - \text{ch}(H(X, \xi|_X), g^{H(X, \xi|_X)}).$$

Let $\zeta(s)$ be the Riemann zeta function. Let $R(x)$ be the power series introduced by Gillet and Soulé [26],

$$(0.9) \quad R(x) = \sum_{\substack{n \geq 1 \\ \text{nodd}}} \left(\sum_1^n \frac{1}{j} + 2 \frac{\zeta'(-n)}{\zeta(-n)} \right) \zeta(-n) \frac{x^n}{n!}.$$

We identify R to the corresponding additive genus.

The purpose of this paper is to prove an extension of a result of Bismut-Lebeau [19, Theorem 0.1], which corresponds to our main result when S is a point. This extension is stated in two Theorems.

Theorem 0.1 — *The following identity holds*

$$(0.10) \quad \begin{aligned} & \widetilde{\text{ch}}(H^{(Y,\eta|_Y)}, g^{H(X,\xi|_X)}, g^{H(Y,\eta|_Y)}) - T(\omega^W, g^\eta) + T(\omega^V, g^\xi) \\ & - \int_X \text{Td}(TX, g^{TX}) T(\xi, g^\xi) + \int_Y \frac{\widetilde{\text{Td}}(TY, TX|_W, g^{TX|_W})}{\text{Td}(N_{Y/X}, g^{N_{Y/X}})} \text{ch}(\eta, g^\eta) \\ & - \int_X \text{Td}(TX) R(TX) \text{ch}(\xi) + \int_Y \text{Td}(TY) R(TY) \text{ch}(\eta) = 0 \quad \text{in} \quad P^S/P^{S,0}. \end{aligned}$$

Assume now that for $j > 0$, $R^j \pi_{V*} \xi_k = 0$ ($0 \leq k \leq m$), $R^j \pi_{V*} \eta = 0$. Then $H(X, \xi|_X) \simeq H(Y, \eta|_Y)$ is concentrated in degree 0. Moreover, we have an acyclic complex of holomorphic vector bundles \mathcal{H} on S ,

$$(0.11) \quad \mathcal{H} : 0 \rightarrow H^0(X, \xi_m) \xrightarrow{v} H^0(X, \xi_{m-1}) \xrightarrow{v} H^0(X, \xi_0) \rightarrow H^0(X, \xi|_X) \rightarrow 0.$$

Let $g^{\mathcal{H}}$ be the obvious L_2 metrics on \mathcal{H} . Let $\widetilde{\text{ch}}(\mathcal{H}, g^{\mathcal{H}}) \in P^S/P^{S,0}$ be the Bott-Chern class of [13] such that

$$(0.12) \quad \begin{aligned} \frac{\bar{\partial}\partial}{2i\pi} \widetilde{\text{ch}}(\mathcal{H}, g^{\mathcal{H}}) &= \text{ch}(H^0(X, \xi|_X), g^{H^0(X, \xi|_X)}) \\ & - \sum_{i=0}^m (-1)^i \text{ch}(H^0(X, \xi_{i|_X}), g^{H^0(X, \xi_{i|_X})}). \end{aligned}$$

Theorem 0.2 — *The following identity holds*

$$(0.13) \quad T(\omega^V, g^\xi) - \sum_{i=0}^m (-1)^i T(\omega^V, g^{\xi_i}) - \widetilde{\text{ch}}(\mathcal{H}, g^{\mathcal{H}}) = 0 \quad \text{in} \quad P^S/P^{S,0}.$$

Our version of Theorems 0.1 and 0.2 is much more precise. In fact, we produce explicit forms γ and δ , which are local on the base S , such that the left-hand side of (0.10) or (0.13) is exactly $\bar{\partial}\gamma + \partial\delta$. Of course this fits with the construction of Bott-Chern classes [13] on V or W or S , where the $P^{V,0}$, $P^{W,0}$ or $P^{S,0}$ ambiguity are local and universal, and with the construction of the analytic torsion forms of [6] and [18], where the anomaly formulas are themselves local on S .

Note that when S is a point, Theorem 0.1 is exactly [19, Theorem 6.1], and Theorem 0.2 is a special case of [19, Theorem 2.1]. In [19], the results are stated in terms of Quillen metrics on $\det R\pi_{V*} \xi \simeq \bigotimes_{i=0}^m (\det R\pi_{V*} \xi^i)^{(-1)^i} \simeq \det R\pi_{V*} \eta$.

We now list the already known results which are compatible with Theorems 0.1 and 0.2. First, when applying $\frac{\bar{\partial}\partial}{2i\pi}$ to both sides of (0.10) or (0.13), we get a trivial identity. Also using [18] and [17], one verifies easily that (0.10) and (0.13) are compatible to variations of all the metrics involved.

Using the transitivity properties of the currents $T(\xi, g^\xi)$ established in [17], one verifies that (0.10) is compatible to composition of immersions.

If S is compact and Kähler, since $\frac{\bar{\partial}\partial}{2i\pi}$ applied to the left-hand sides of (0.10) or (0.13) gives a known identity, a simple application of the $\bar{\partial}\partial$ lemma of [28, p. 149] shows that the left-hand side of (0.10) or (0.13) is the sum of (p, p) cohomology classes on S .

If S is compact and Kähler, then V and W are compact and Kähler. In [11], Berthomieu and Bismut have calculated the behaviour of the Quillen metric on the determinant of the cohomology by a proper submersion in terms of higher analytic torsion forms. If S is compact and Kähler, we deduce from [11] that if Δ is the left-hand side of (0.10), the integral of Δ on a smooth complex submanifold of S vanishes, or almost equivalently, that the pairing of Δ with the Chern character of a holomorphic vector bundle on S gives 0. However the Hodge conjecture would be needed to deduce from this fact that Δ vanishes in $P^S/P^{S,0}$.

Let us assume that A is the ring of integers of a number field k . Suppose that V, W, S are arithmetic varieties over $\text{Spec}(A)$, and that

$$(0.14) \quad \begin{array}{ccc} W & & \\ \downarrow i & \searrow \pi_W & \\ V & \xrightarrow{\pi_V} & S \end{array}$$

is a diagram of morphisms over A . We assume that π_V and π_W are smooth and projective, and that i is a closed immersion. Let X, Y be the fibres of π_V, π_W .

Let Σ be the finite set of complex embeddings of k in \mathbf{C} . If $\sigma \in \Sigma$, let V_σ be the complex variety obtained by extending the scalars from A to \mathbf{C} . Let V_∞ the complex manifold $V_\infty = \bigcup_{\sigma \in \Sigma} V_\sigma$. We define W_∞, S_∞ in the same way. Let F_∞ be the conjugation map.

Let η be an algebraic vector bundle on W , let (ξ, v) be a complex of algebraic vector bundles on V which resolves $i_*\eta$.

We suppose that at ∞ , i.e. over $V_\infty, W_\infty \dots$, objects we have considered before have been introduced, i.e. forms $\omega^{V_\infty}, \omega^{W_\infty}$, metrics $g^{\xi^0}, \dots, g^{\xi^m}, g^\eta$, which are F_∞ -invariant.

Let $\widehat{\text{CH}}(V), \widehat{\text{CH}}(W) \dots$ be the arithmetic Chow groups of Gillet and Soulé [24]. Let $A^{pp}(V_{\mathbf{R}})$ be the vector space of real smooth forms α on V_∞ of type (p, p) , with $F_\infty^* \alpha = (-1)^p \alpha$. Let $\widetilde{A}^{p,p}(V_{\mathbf{R}})$ be the quotient $\widetilde{A}^{p,p}(V_{\mathbf{R}}) = \frac{A^{pp}(V_{\mathbf{R}})}{\text{Im} \bar{\partial} + \text{Im} \partial}$. Let a be the embedding $\bigoplus_p \widetilde{A}^{p,p}(V_{\mathbf{R}}) \rightarrow \widehat{\text{CH}}(V)$. If (E, g^E) is an algebraic Hermitian vector bundle over V , let $\widehat{\text{Td}}^p(E, g^E), \widehat{\text{ch}}(E, g^E) \in \widehat{\text{CH}}(V)$ be the corresponding characteristic classes

of Gillet and Soulé [25]. Let $\mathrm{Td}^A(TX, g^{TX}) \in \widehat{\mathrm{CH}}(V)$ be the modification of the class $\widehat{\mathrm{Td}}$ introduced by Gillet and Soulé in [26].

Let us recall that in [26], Gillet and Soulé have defined $\widehat{\mathrm{ch}}(\pi_{W!}(\eta, g^\eta)) \in \widehat{\mathrm{CH}}(S)$ by the formula

$$(0.15) \quad \widehat{\mathrm{ch}}(\pi_{W!}(\eta, g^\eta)) = \widehat{\mathrm{ch}}(R\pi_{W*}\eta, g^{R\pi_{W*}\eta}) - aT(\omega^W, g^\eta).$$

Similarly, we can define $\widehat{\mathrm{ch}}(\pi_{V!}(\xi_i, g^{\xi_i}))$, $\widehat{\mathrm{ch}}(\pi_{V!}(\xi, g^\xi))$.

In [26], Gillet and Soulé formulated the conjecture that the following Riemann-Roch-Grothendieck formula holds

$$(0.16) \quad \widehat{\mathrm{ch}}(\pi_{W!}(\eta, g^\eta)) = \pi_* \left[\mathrm{Td}^A(TY, g^{TY}) \widehat{\mathrm{ch}}(\eta, g^\eta) \right].$$

In [27], by using [19], they proved (0.16) for the first Chern class. In [22], Faltings has given a proof of (0.16) for arbitrary Chern classes, based on a deformation to the normal cone technique.

By using [17, Theorem 4.13], we see that Theorem 0.1 implies that

$$(0.17) \quad \widehat{\mathrm{ch}}(\pi_{V!}(\xi, g^\xi)) - \widehat{\mathrm{ch}}(\pi_{W!}(\eta, g^\eta)) = \pi_{V*} \left[\mathrm{Td}^A(TX, g^{TX}) \widehat{\mathrm{ch}}(\xi, g^\xi) \right] \\ - \pi_{W*} \left[\mathrm{Td}^A(TY, g^{TY}) \widehat{\mathrm{ch}}(\eta, g^\eta) \right].$$

Also from Theorem 0.2, we get

$$(0.18) \quad \widehat{\mathrm{ch}}(\pi_{V!}(\xi, g^\xi)) - \sum_{i=0}^m (-1)^i \widehat{\mathrm{ch}}(\pi_{V!}(\xi_i, g^{\xi_i})) = a\widetilde{\mathrm{ch}}(\mathcal{X}, g^\mathcal{X}).$$

So (0.17)-(0.18) are compatible with the conjectured formula (0.16) of Gillet-Soulé.

Let us now briefly describe the strategy which is used in this paper for the proof of Theorem 0.1.

1. The case where S is a point and the general case

The general strategy of the proof of Theorem 0.1 is roughly the same as the one in [19] for the case where S is a point. Namely, in the context of the local families index theorem of [4], and in the formalism of Quillen's superconnections [32], we produce a differential form $\beta_{u,T}$ on $\mathbf{R}_+^* + \mathbf{R}_+^* \times S$, such that if $d_{u,T}$ denotes the partial exterior differential with respect to u, T , then

$$(0.19) \quad d_{u,T}\beta = \bar{\partial}\gamma + \partial\delta.$$

If Γ is a closed rectangular contour in $\mathbf{R}_+^* \times \mathbf{R}_+^*$, which bounds a domain Δ , we obtain the basic identity

$$(0.20) \quad \int_{\Gamma} \beta = \bar{\partial} \int_{\Delta} \gamma + \partial \int_{\Delta} \delta,$$

so that $\int_{\Gamma} \beta \in P^{S,0}$.

Theorem 0.1 will be obtained by deforming Γ in $\mathbf{R}_+^* \times \mathbf{R}_+^*$ to its boundary in \mathbf{R}^2 .

This strategy is formally the same as in [19]. Also since the construction of the analytic torsion forms in [18] is, roughly speaking, a perturbation of the construction of the Ray-Singer torsion [34] using the infinitesimal deformations of the fibres X or Y , most of the intermediate results or techniques of [19] are used in the present paper. Therefore we refer to the introduction of [19] for a description of the techniques which are used there, while we concentrate on some of the essential differences with [19].

2. The right-hand side of (0.20)

If S is compact and Kähler, $P^{S,0}$ is closed in P^S . In this case, if one is just interested in establishing a non local form of (0.10), i.e. just the existence of non explicit (i.e. non universal and non local) forms γ and δ such that the left-hand side of (0.10) is $\bar{\partial}\gamma + \partial\delta$, one can skip the technically heavy Sections 5.7-5.9, 6.6-6.8, 11.11, 12.7 and 13.13-13.14.

In the general case, because S is non compact and also because we want to obtain the best result as possible, i.e. a local universal explicit form of the right-hand side of (0.10), we need to study the right-hand side of (0.20) in much detail. The estimates on this right-hand side are much harder to obtain (we have to control double integrals in u, T and not only integrals in u or T).

3. Relative local index theory

While local index theory was used in [19], and in particular the local index theory rescaling technique of Getzler [23], here we work in the context of the local relative index theorem of [4]. In particular the standard Levi-Civita connection of a Riemannian manifold is replaced by the Levi-Civita superconnection of a fibration [4].

In this paper, we adapt in our context the rescaling techniques developed by Berline-Getzler-Vergne [3] to establish the local families index theorem of [4].

The algebra of the families index theorem of [4] being more demanding than the algebra for the standard local index theorem, this introduces unavoidable complications with respect to [19].

As explained in [4], [12], [11], the Levi-Civita superconnection of a fibration [4] can be thought of as the adiabatic limit of the Levi-Civita connection of the total space, when the metric is blown up horizontally, and the horizontal Clifford variables are properly rescaled in the sense of Getzler [23]. Roughly speaking, our proof of Theorem 0.1 can be understood, to a certain extent, as the adiabatic limit of the

proof of [19]. Still this analogy provides us only with a partial intuition of the analysis which is needed in the proof.

4. The horizontal vector bundles $T^H V$ and $T^H W$

Using the anomaly formulas of [18], we can reduce the proof of Theorem 0.1 to the case where $\omega^W = i^* \omega^V$.

Let $T^H V, T^H W$ be the orthogonal subbundles to TX, TY in TV, TW with respect to ω^V, ω^W . In general, $T^H V|_W$ and $T^H W$ do not coincide. As explained in Section 7.5, there is a cohomological obstruction to finding ω^V such that $T^H V|_W = T^H W$. We are thus forced to work in the general case where $T^H V|_W \neq T^H W$. This is in dramatic contrast with the situation one meets in the C^∞ category, where one can always assume that $T_{\mathbf{R}}^H V|_W = T_{\mathbf{R}}^H W$.

In [4], [14], the bundles $T_{\mathbf{R}}^H V, T_{\mathbf{R}}^H W$ are used to construct unitary connections $\nabla^{\Omega(X, \xi|_X)}, \nabla^{\Omega(Y, \eta|_Y)}$ on $\Omega(X, \xi|_X), \Omega(Y, \eta|_Y)$. Also in [19], for $T \geq 1$, a family of embeddings $J_T: \Omega(Y, \eta|_Y) \rightarrow \Omega(X, \xi|_X)$ is constructed. Roughly speaking, in [19], $\Omega(Y, \eta|_Y)$ is viewed as a subcomplex of currents on X , localized on Y . Here, because $T^H V|_W \neq T^H W$, the connection $\nabla^{\Omega(X, \xi|_X)}$ does not “preserve” $\nabla^{\Omega(Y, \eta|_Y)}$. This has dramatic analytic consequences. In particular, when written in matrix form as in [19], our operators do not have the preferred asymptotic structure, which plays a key role in the analysis of [19].

To deal with this difficulty, we construct in Chapter 7 an extension of $T^H W$ to the whole manifold V , and we conjugate the Levi-Civita superconnection of V by an operator which measures the non coincidence of $T^H V$ with $T^H W$. Because of the need to control various local cancellations, the extension of $T^H W$ to V is non arbitrary.

After conjugation, the Levi-Civita superconnection of V becomes analytically more pleasant, but it contains many more extra terms. As a deformation parameter T tends to infinity, the fact that these terms vanish asymptotically follows from mysterious identities established in Chapter 1.

5. The Levi-Civita superconnection $B_{u,T}$ and its curvature $B_{u,T}^2$

Put $D^X = \bar{\partial}^X + \bar{\partial}^{X*}$, $V = v + v^*$. In [19, Sections 8 and 9], the analysis of the supertraces of operators like $\exp(-u^2(D^X + TV)^2)$ as $T \rightarrow +\infty$ was done for $u \geq u_0 > 0$ by writing the operator $D^X + TV$ in matrix form. Still, because local cancellations had also to be controlled as $u \rightarrow 0$, these cancellations not being property understood on the operator $u(D^X + TV)$, in [19, Section 13], for $u \in]0, 1]$, $T \geq 1$, the operator $u^2(D^X + TV)^2$ had to be written in matrix form, and the local cancellations mechanism controlled on this matrix form.

Here, the analogue of $D^X + TV$ is a superconnection $A_{1,T}$. Only its square $A_{1,T}^2$ is a fibrewise elliptic operator along the fibres X . Even when $u \geq u_0 > 0$, we are thus forced to deal with the operator $A_{1,T}^2$ and not with $A_{1,T}$ itself.

Still some features of [19, Sections 8 and 9] are preserved. Namely, in Chapters 8 and 13, we calculate the asymptotics as $T \rightarrow +\infty$ of the conjugate superconnection $\tilde{A}_{1,T}$ in two different trivializations of $\pi_V^* \Lambda(T_{\mathbf{R}}^* S) \hat{\otimes} \Lambda(T^{*(0,1)} X) \hat{\otimes} \xi$ near W . This extends corresponding results of [19, Section 8].

6. The lower part of the spectrum of $D^X + TV$ and the asymptotics of the Chern character superconnection forms as $u \rightarrow +\infty$

In [19, Section 9], it was shown that as $u \rightarrow +\infty$, the supertraces of operators involving $\exp(-u^2(D^X + TV)^2)$ converge like $c \exp(-Cu^2)$, with $c > 0$, $C > 0$ uniformly in $T \in [1, +\infty[$. The proof uses in particular the fact that as $T \rightarrow +\infty$, the nonzero eigenvalues of $(D^X + TV)^2$ stay away from 0.

Here, by result of Berline-Getzler-Vergne [3, Section 9], for a given $T \geq 1$, the Chern character superconnection forms associated to a superconnection $B_{u,T}$ converge as $u \rightarrow +\infty$ like $\mathcal{O}(\frac{1}{u})$. Obtaining the required uniformity in $T \in [1, +\infty[$ is more difficult. In effect the control of the superconnection Chern character forms as $u \rightarrow +\infty$ or $T \rightarrow +\infty$ involve two distinct matrix decompositions of the curvature $B_{u,T}^2$, which have to be shown to be compatible. The corresponding arguments are given in Chapter 9.

7. The genus R and the higher analytic torsion forms of the exact sequence

$$0 \rightarrow TY \rightarrow TX|_W \rightarrow N_{Y/X} \rightarrow 0$$

As in [19], the genus R of Gillet-Soulé [26] appears in Theorem 0.1 through the explicit computation in [6] of higher analytic torsion forms associated to the exact sequence of holomorphic Hermitian vector bundles on W

$$(0.21) \quad 0 \rightarrow TY \rightarrow TX|_W \rightarrow N_{Y/X} \rightarrow 0.$$

As explained in Chapter 15, some of the computations of [6] and of [19, Section 14] appear to be just a special case of the arguments used in this paper, when applied to the family of embeddings $TY \rightarrow TX|_W$.

As explained in the introduction to [19], an alternative strategy to the proof of the main result of [19] or of Theorem 0.1 is the deformation to the normal cone technique of Baum-Fulton-MacPherson [2], [17, Section 4]. Arguments in support of the main steps of such a program have been described by Faltings in [22]. The deformation to the normal cone replaces the embedding $i: W \rightarrow V$ by the embedding $i': W \rightarrow \mathbf{P}(N_{W/V} \oplus 1)$ and the complex (ξ, ν) by a canonical Koszul complex on

$\mathbf{P}(N_{W/V} \oplus 1)$. The deformation to the normal cone technique replaces a smooth fibration by a singular fibration, and the whole point is to control the analytic torsion forms through the singularity. To overcome this difficulty, Faltings replaces the given Kähler metric on the smooth fibre by a metric on the log tangent space, which is not Kähler, hence the need to control non explicit anomaly formulas. Once the reduction to $\mathbf{P}(N_{W/V} \oplus 1)$ is done, the strategy of [22] is to use a relative version of [11], (sketched in [22, p. 75-76]) which reduces the problem to the explicit computation of the higher analytic torsion forms of the fibration $\mathbf{P}(N_{W/V} \oplus 1) \rightarrow W$. This final computation is obtained by using the results of Gillet and Soulé [26], and explains the appearance of R in (0.10).

In some sense, the program of [19] and of the present paper is an analytic version of the deformation to the normal cone technique, in which the three steps described before are reduced to one step. In particular the analysis wipes out the intermediate $\mathbf{P}(N_{W/V} \oplus 1) \rightarrow W$ and replaces it by the exact sequence $0 \rightarrow TY \rightarrow TX|_W \rightarrow N_{Y/X} \rightarrow 0$, whose analytic torsion forms were calculated in [6].

Needless to say, the deformation of the normal cone technique was used in [17] to evaluate the current $T(\xi, g^\xi)$ in terms of the arithmetic characteristic classes of [24]-[25], but the analysis of [17] only involves finite dimensional objects.

This paper has been written as a companion paper to [19], to which the reader is referred when necessary. In particular, most of the technical comments in [19] apply also to this paper, and have not been repeated. Let us also point out that as in [19], finite propagation speed for solutions of hyperbolic equations [21], [35] plays an important role in the proofs.

This paper is organized as follows. In Chapter 1, we establish various results on the differential geometry of families of smooth embeddings, in the C^∞ category. In Chapter 2, we recall the result of [14] and [18] on higher analytic torsion forms. In Chapter 3, we describe the basic geometric setting of (0.1), and also the objects which appear in (0.10) and (0.13).

In Chapter 4, we construct the form β in (0.14), and we establish (0.20).

In Chapter 5, we recall the results of [6] on the higher analytic torsion forms associated to a short exact sequence.

In Chapter 6, we prove Theorem 0.1. The proof is based on several intermediate results, whose proof occupies Chapters 7-13. This Chapter corresponds to [19, Section 6].

In Chapter 7, we extend $T^H W$ to V .

Chapters 8-13 are devoted to the proofs of the intermediate results which were alluded to, and correspond roughly to [19, Sections 8-13]. In Chapter 8-9, we calculate the asymptotics of supertraces involving $\exp(-B_{u,T}^2)$ (where $B_{u,T}$ is the superconnection version of $u(D^X + TV)$), in the range $u \geq 1, T \geq 1$. In Chapter 10,

we give a description of the bundles over S of the kernels of $D^X + TV$, as $T \rightarrow +\infty$. In Chapter 11, we establish uniform estimates on supertraces involving $\exp(-A_{u,T}^2)$ (where $A_{u,T}$ is the superconnections analogue of $uD^X + TV$) in the range $0 < u \leq 1$, $1 \leq T \leq 1/u$. If $u \rightarrow 0$, $T \simeq 1/u$, the corresponding supertraces are studied in Chapter 12, and for $u \rightarrow 0$, $T \geq 1/u$ in Chapter 13.

In Chapter 14, we establish Theorem 0.2 by exchanging the roles of u and T . The proof is much simpler than the proof of Theorem 0.1, and is just briefly sketched.

Finally, in Chapter 15, we show that the objects appearing in [6] in the construction of the higher analytic torsion forms of a short exact sequence are a toy model for many of the arguments used in Chapters 8-13, even though the results of [6] are used in the proof of Theorem 0.1.

The results contained in this paper have been announced in [10].

1. Families of immersions and connections on the relative tangent bundle

Let $\pi: V \rightarrow S$ be a submersion of smooth manifolds with compact fibre X . Let TX be the relative tangent bundle, and let $T^H V$ be a subbundle of TV such that $TV = T^H V \oplus TX$. Let g^{TX} be a metric on TX .

In this Chapter we recall the construction in [4] of a connection ∇^{TX} on TX , which is canonically associated to these datas, and of various corresponding tensors.

Also let $i: W \rightarrow V$ is an embedding of manifolds which both fibre on S , let $i: Y \rightarrow X$ be the corresponding fibres of W and V over S . Let g^{TV} be a metric on TV , let $T^H V, T^H W$ be the subbundles of TV, TW which are orthogonal to TX, TY . Let g^{TX}, g^{TY} be the metrics induced by g^{TV} on TX, TY . Let ∇^{TX}, ∇^{TY} be the associated connections on TX, TY . The main purpose of this Chapter is to establish various relations between the tensors associated to TX and TY .

1.1 A canonical connection on the relative tangent bundle of a fibration

Let $\pi: V \rightarrow S$ be a smooth submersion of smooth manifolds with compact fibre X . Let $TX = TV/S$ be the relative tangent bundle to the fibres X .

Let $T^H V$ be a smooth subbundle of TV such that

$$(1.1) \quad TV = T^H V \oplus TX.$$

Let P^{TX} be the projection $TV = T^H V \oplus TX \rightarrow TX$.

Let g^{TX} be a metric on TX . It was shown in [4, Section 1] that the datas $(\pi, g^{TX}, T^H V)$ determine an Euclidean connection ∇^{TX} on (TX, g^{TX}) . Let us briefly describe the construction of [4].

Let g^{TS} be an Euclidean metric on TS . Let ∇^{TS} be the Levi-Civita connection on (TS, g^{TS}) . We equip $TV = T^H V \oplus TX$ with the metric $g^{TV} = \pi^* g^{TS} \oplus g^{TX}$. Let $\nabla^{TV, L}$ be the Levi-Civita connection on (TV, g^{TV}) . Set

$$(1.2) \quad \nabla^{TX} = P^{TX} \nabla^{TV, L}.$$

Let ∇^{TV} be the connection on $TV = T^H V \oplus TX$

$$(1.3) \quad \nabla^{TV} = \pi^* \nabla^{TS} \oplus \nabla^{TX}.$$

Let T be the torsion of ∇^{TV} . Set

$$(1.4) \quad S = \nabla^{TV,L} - \nabla^{TV}.$$

Then S is a 1 form on V with values in antisymmetric elements of $\text{End}(TV)$. Classically, if $A, B, C \in TV$

$$(1.5) \quad \begin{aligned} S(A)B - S(B)A + T(A, B) &= 0, \\ 2 \langle S(A)B, C \rangle + \langle T(A, B), C \rangle + \langle T(C, A), B \rangle - \langle T(B, C), A \rangle &= 0. \end{aligned}$$

Then by [4, Theorem 1.9], we know that

- The connection ∇^{TX} preserves g^{TX} .
- ∇^{TX}, T and the (3,0) tensor $\langle S(\cdot), \cdot \rangle$ do not depend on g^{TS} .
- T takes its values in TX , and vanishes on $TX \times TX$.
- For any $A \in TV$, $S(A)$ maps TX into $T^H V$.
- For any $A, B \in T^H V$, $S(A)B \in TX$.
- If $A = T^H V$, $S(A)A = 0$.

Only the last statement is not proved explicitly in [4]. However it immediately follows from (1.5) and from the fact that T takes its values in TX .

From (1.5), we derive easily that if $A \in T^H V$, $B, C \in TX$, then

$$(1.6) \quad \langle T(A, B), C \rangle = \langle T(A, C), B \rangle = - \langle S(B)C, A \rangle.$$

If $U \in TS$, let $U^H \in T^H V$ be its lift in $T^H V$, so that $\pi_* U^H = U$. If U is a smooth vector field on B , the Lie derivative operator L_{U^H} acts naturally on the tensor algebra of TX . In particular, if $U \in TS$, $(g^{TX})^{-1} L_{U^H} g^{TX}$ defines a 1-form on B , with values in self-adjoint endomorphisms of TX .

Theorem 1.1 — *The connection ∇^{TX} on (TX, g^{TX}) is characterized by the following two properties :*

- *On each fibre X , it restricts to the Levi-Civita connection of (TX, g^{TX}) .*
- *If $U \in TS$, then*

$$(1.7) \quad \nabla_{U^H}^{TX} = L_{U^H} + \frac{1}{2} (g^{TX})^{-1} L_{U^H} g^{TX}.$$

The following identities hold :

- *If $A, B \in T^H V$,*

$$(1.8) \quad T(A, B) = -P^{TX}[A, B].$$

– If $U \in TS$, $A \in TX$,

$$(1.9) \quad T(U^H, A) = \frac{1}{2}(g^{TX})^{-1}L_{UH}g^{TX}A.$$

Proof. From its construction, it is clear that the restriction of ∇^{TX} to a fibre X is the Levi-Civita connection of the fibre. Let A be a smooth section of TX , let U be a smooth section of TS . Then

$$(1.10) \quad \begin{aligned} U^H \langle A, A \rangle &= 2 \langle \nabla_{UH}^{TX} A, A \rangle, \\ U^H \langle A, A \rangle &= 2 \langle L_{UH} A, A \rangle + \langle (g^{TX})^{-1}L_{UH}g^{TX}A, A \rangle. \end{aligned}$$

Since $\nabla_A^{TV}U^H = 0$, from (1.10), we obtain

$$(1.11) \quad \langle T(U^H, A), A \rangle = \frac{1}{2} \langle (g^{TX})^{-1}L_{UH}g^{TX}A, A \rangle.$$

By (1.6), both sides of (1.11) define symmetric bilinear forms on TX . So we get from (1.11)

$$(1.12) \quad T(U^H, A) = \frac{1}{2}(g^{TX})^{-1}L_{UH}g^{TX}A.$$

Also

$$(1.13) \quad \nabla_{UH}^{TX}A = [U^H, A] + T(U^H, A).$$

From (1.12), (1.13), we get (1.7), (1.9). Finally if U, V are smooth sections of TS ,

$$(1.14) \quad \begin{aligned} T(U^H, V^H) &= \nabla_{UH}^{TV}V^H - \nabla_{V^H}^{TV}U^H - [U^H, V^H] = \\ &= (\nabla_U^{TS}V)^H - (\nabla_{V^H}^{TS}U)^H - [U^H, V^H] \\ &= [U, V]^H - [U^H, V^H] = -P^{TX}[U^H, V^H]. \end{aligned}$$

The proof of Theorem 1.1 is completed. \square

1.2 An identity on the connection on the relative tangent bundle

Let now g^{TV} be a metric on TV which has the following properties:

- g^{TV} induces the given metric g^{TX} on TX .
- $T^H V$ is exactly the orthogonal bundle to TX in TV with respect to g^{TV} .

Let $\nabla^{TV, L}$ be the Levi-Civita connection on (TV, g^{TV}) . We denote by $\langle \cdot, \cdot \rangle_{g^{TV}}$ the scalar product with respect to g^{TV} . Still $\langle S(\cdot), \cdot \rangle$ denotes the tensor associated to $T^H V$, g^{TX} which was described in Section 1.1.

Now we recall a result of [14, Theorem 1.2].

Theorem 1.2 — *The following identity holds*

$$(1.15) \quad \nabla^{TX} = P^{TX} \nabla^{TV, L}.$$

Moreover if A, A' are smooth sections of TS , if U, U' are smooth sections of TX , if $Y = U' + A^H, Y' = A'^H$, then

$$(1.16) \quad \left\langle \nabla_U^{TV, L} Y, Y' \right\rangle_{g^{TV}} - \left\langle \nabla_U^{TV, L} Y', Y \right\rangle_{g^{TV}} = 2 \langle S^V(U) Y, Y' \rangle.$$

Remark 1.3. Formula (1.16) shows in particular that the second fundamental form of the fibres X with respect to g^{TV} can be evaluated in terms of S^V .

1.3 Families of immersions and the corresponding connections on the relative tangent bundles

Let $i: W \rightarrow V$ be an embedding of smooth manifolds. Let $\pi_V: V \rightarrow S$ be a smooth submersion with compact fibre X , whose restriction $\pi_W: W \rightarrow S$ is a smooth submersion with compact fibre Y . Thus we have the diagram

$$(1.17) \quad \begin{array}{ccc} Y & \longrightarrow & W \\ \downarrow i & & \downarrow i \\ X & \longrightarrow & V \end{array} \begin{array}{c} \searrow \pi_W \\ \xrightarrow{\pi_V} S \end{array}$$

Let $TX = TV/S, TY = TW/S$ be the relative tangent bundles to the fibres X, Y . Let $N_{W/V}$ be the normal bundle to W in V , let $N_{Y/X}$ be the normal bundle to Y in X . Clearly

$$(1.18) \quad N_{W/V} = N_{Y/X}.$$

Let $T^H V$ be a smooth subbundle of TV such that

$$(1.19) \quad TV = T^H V \oplus TX.$$

Let $\tilde{N}_{Y/X}$ be a smooth subbundle of $TX|_W$ such that

$$(1.20) \quad TX|_W = \tilde{N}_{Y/X} \oplus TY.$$

Clearly

$$(1.21) \quad \begin{array}{l} T^H V \simeq \pi^* TS, \\ \tilde{N}_{Y/X} \simeq N_{Y/X}. \end{array}$$

By (1.19), (1.20), we get

$$(1.22) \quad TV|_W = T^H V|_W \oplus \tilde{N}_{Y/X} \oplus TY.$$

By (1.22), we see that there is a well-defined morphism

$$(1.23) \quad \frac{TW}{TY} \rightarrow T^H V|_W \oplus \tilde{N}_{Y/X},$$

and this morphism maps $\frac{TW}{TY}$ into a subbundle of TW .

Definition 1.4. Let $T^H W$ be the subbundle of TW which is the image of $\frac{TW}{TY}$ by the morphism (1.23).

Clearly

$$(1.24) \quad TW = T^H W \oplus TY.$$

Remark 1.5. The simplest case is of course when

$$(1.25) \quad T^H V|_W = T^H W.$$

However in general this assumption is not verified.

Let now g^{TV} be a metric on TV . Let g^{TW} be the induced metric on TW , let g^{TX}, g^{TY} be the induced metrics on TX, TY . Note that even is g^{TV} is of the type considered at the very beginning of Section 1.1, in general, g^{TW} is not of this type.

We identify $N_{Y/X}$ with the orthogonal bundle $\tilde{N}_{Y/X}$ to TY in $TX|_W$ with respect to $g^{TX}|_W$. Let $g^{N_{Y/X}}$ be the induced metric on $N_{Y/X}$.

Definition 1.6. Let $T^H V$ (resp. $T^H W$) be the subbundle of TV (resp. TW) which is the orthogonal bundle to TX (resp. TY) in TV (resp. TW) with respect to g^{TV} (resp. g^{TW}).

Since the splitting

$$TV|_W = T^H V|_W \oplus N_{Y/X} \oplus TY$$

is orthogonal, one verifies immediately that $T^H W$ coincides with the bundle defined in Definition 1.4, associated to $T^H V$ and $\tilde{N}_{Y/X} = N_{Y/X}$. In particular

$$T^H W \subset T^H V|_W \oplus N_{Y/X}.$$

Remark 1.7. The manifold W intersects the fibres X orthogonally if and only if $T^H V|_W = T^H W$.

To the triples $(\pi_V, g^{TX}, T^H V)$ (resp. $(\pi_W, g^{TY}, T^H W)$), we can associate the objects we constructed in Section 1.1.

In particular TX, TY are now equipped with connections ∇^{TX}, ∇^{TY} which preserve the metrics g^{TX}, g^{TY} . We also denote by T^V (resp. T^W), the tensor T constructed in Section 1.1, which is associated to $(\pi_V, T^H V, g^{TX})$ (resp. $(\pi_W, T^H W, g^{TY})$). Recall that $T^H W \subset T^H V|_W \oplus N_{Y/X}$. If $A \in TB$, let $A^{H,V} \in T^H V, A^{H,W} \in T^H W$ be the horizontal lift of A in $T^H V, T^H W$, so that $\pi_{V*} A^{H,V} = A, \pi_{W*} A^{H,W} = A$.

Let $P^{TY}, P^{N_{Y/X}}$ be the orthogonal projections $TX|_Y \rightarrow TY, TX|_Y \rightarrow N_{Y/X}$.

Definition 1.8. If $A \in TS$, let $A^{H, N_{Y/X}} \in N_{Y/X}$ be such that

$$(1.26) \quad A^{H, W} = A^{H, V} + A^{H, N_{Y/X}} .$$

Theorem 1.9 — *The connection ∇^{TY} is given by*

$$(1.27) \quad \nabla^{TY} = P^{TY} \nabla^{TX}|_Y .$$

Proof. Let $\nabla^{TV, L}$ (resp. $\nabla^{TW, L}$) be the Levi-Civita connection on (TV, g^{TV}) (resp. (TW, g^{TW})). Let P^{TW} be the orthogonal projection operator $TV|_W \rightarrow TW$. Clearly

$$(1.28) \quad \nabla^{TW, L} = P^{TW} \nabla^{TV, L} .$$

Let P^{TX}, P^{TY} be the orthogonal projections $TV = T^H V \oplus TX \rightarrow TX$, $TW = T^H W \oplus TY \rightarrow TY$. By Theorem 1.2,

$$(1.29) \quad \begin{aligned} \nabla^{TX} &= P^{TX} \nabla^{TV, L} , \\ \nabla^{TY} &= P^{TY} \nabla^{TW, L} . \end{aligned}$$

From (1.28), (1.29), we get (1.27). □

Let $\nabla^{N_{Y/X}}$ be the connection on $N_{Y/X}$,

$$(1.30) \quad \nabla^{N_{Y/X}} = P^{N_{Y/X}} \nabla^{TX} .$$

Then $\nabla^{N_{Y/X}}$ preserves the metric $g^{N_{Y/X}}$.

Put

$$(1.31) \quad {}^0 \nabla^{TX}|_W = \nabla^{TY} \oplus \nabla^{N_{Y/X}} .$$

Then ${}^0 \nabla^{TX}|_W$ is a metric preserving connection on $TX|_W = TY \oplus N_{Y/X}$. Set

$$(1.32) \quad A = \nabla^{TX}|_W - {}^0 \nabla^{TX}|_W .$$

Then A is a 1-form on W with values in antisymmetric elements of $\text{End}(TX|_W)$ exchanging TY and $N_{Y/X}$.

Since ∇^{TX} restricts to the Levi-Civita connection of the fibres X , if $B \in TY$, $C \in TY$,

$$(1.33) \quad A(B)C - A(C)B = 0 .$$

To keep in line with our previous notation, we denote by $\langle \cdot, \cdot \rangle$ the scalar products which only depend on the datas $(\pi_V, T^H V, g^{TX})$ or $(\pi_W, T^H W, g^{TY})$, while using the notation $\langle \cdot, \cdot \rangle_{g^{TV}}$, $\langle \cdot, \cdot \rangle_{g^{TW}}$ for the scalar products on TV , TW associated to the auxiliary g^{TV} , g^{TW} .

Theorem 1.10 — If $B \in TY$, $C \in TS$, $D \in TS$,

$$(1.34) \quad \langle S^V(B)C^{H,W}, D^{H,W} \rangle = \langle S^W(B)C^{H,W}, D^{H,W} \rangle \\ - \frac{1}{2} \langle \nabla_B^{TX} C^{H,N_{Y/X}}, D^{H,N_{Y/X}} \rangle + \frac{1}{2} \langle C^{H,N_{Y/X}}, \nabla_B^{TX} D^{H,N_{Y/X}} \rangle.$$

If $B \in TY$, $C \in TS$,

$$(1.35) \quad P^{TY} T^V(B, C^{H,V}) = T^W(B, C^{H,W}) + A(B)C^{H,N_{Y/X}}, \\ \nabla_B^{N_{Y/X}} C^{H,N_{Y/X}} = P^{N_{Y/X}} T^V(B, C^{H,V}) + A(C^{H,W})B.$$

Proof. Take $B \in TY$, $C, D \in TS$. Then using the properties of S^V listed in Section 1.1, we get

$$\langle S^V(B)C^{H,W}, D^{H,W} \rangle = \langle S^V(B)(C^{H,V} + C^{H,N_{Y/X}}), D^{H,V} + D^{H,N_{Y/X}} \rangle = \\ \langle S^V(B)C^{H,V}, D^{H,V} \rangle + \langle S^V(B)C^{H,V}, D^{H,N_{Y/X}} \rangle + \\ \langle S^V(B)C^{H,N_{Y/X}}, D^{H,V} \rangle.$$

Let $\nabla^{TV,L}$ be the Levi-Civita connection on (TV, g^{TV}) . By construction $T^H V$ is orthogonal to TX with respect to g^{TV} , and g^{TV} induces the metric g^{TX} on TX . Then using Theorem 1.2, we get

$$(1.36) \quad \langle S^V(B)C^{H,W}, D^{H,W} \rangle = \frac{1}{2} \left(\left\langle \nabla_B^{TV,L} C^{H,V}, D^{H,V} \right\rangle_{g^{TV}} \right. \\ - \left\langle C^{H,V}, \nabla_B^{TV,L} D^{H,V} \right\rangle_{g^{TV}} + \left\langle \nabla_B^{TV,L} C^{H,V}, D^{H,N_{Y/X}} \right\rangle_{g^{TV}} \\ - \left\langle C^{H,V}, \nabla_B^{TV,L} D^{H,N_{Y/X}} \right\rangle_{g^{TV}} + \left\langle \nabla_B^{TV,L} C^{H,N_{Y/X}}, D^{H,V} \right\rangle_{g^{TV}} \\ \left. - \left\langle C^{H,N_{Y/X}}, \nabla_B^{TV,L} D^{H,V} \right\rangle_{g^{TV}} \right).$$

Equivalently, using (1.15), and (1.29), we obtain

$$(1.37) \quad \langle S^V(B)C^{H,W}, D^{H,W} \rangle = \frac{1}{2} \left(\left\langle \nabla_B^{TV,L} C^{H,W}, D^{H,W} \right\rangle_{g^{TV}} \right. \\ - \left\langle C^{H,W}, \nabla_B^{TV,L} D^{H,W} \right\rangle_{g^{TV}} - \left\langle \nabla_B^{TX} C^{H,N_{Y/X}}, D^{H,N_{Y/X}} \right\rangle \\ \left. + \left\langle C^{H,N_{Y/X}}, \nabla_B^{TX} D^{H,N_{Y/X}} \right\rangle \right).$$

Let $\nabla^{TW,L}$ be the Levi-Civita connection on (TW, g^{TW}) . Then

$$(1.38) \quad \left\langle \nabla_B^{TV,L} C^{H,W}, D^{H,W} \right\rangle_{g^{TV}} = \left\langle \nabla_B^{TW,L} C^{H,W}, D^{H,W} \right\rangle_{g^{TW}}.$$

By construction, $T^H W$ is orthogonal to TY with respect to g^{TW} , and moreover g^{TW} induces the metric g^{TY} on TY . By reapplying Theorem 1.2, we obtain

$$(1.39) \quad \langle S^W(B)C^{H,W}, D^{H,W} \rangle = \frac{1}{2} \left\langle \nabla_B^{TW,L} C^{H,W}, D^{H,W} \right\rangle_{g^{TW}} - \left\langle C^{H,W}, \nabla_B^{TW,L} D^{H,W} \right\rangle_{g^{TW}}.$$

From (1.37)-(1.39), we obtain

$$(1.40) \quad \langle S^V(B)C^{H,W}, D^{H,W} \rangle = \langle S^W(B)C^{H,W}, D^{H,W} \rangle + \frac{1}{2} \left(-\langle \nabla_B^{TX} C^{H,N_{Y/X}}, D^{H,N_{Y/X}} \rangle + \langle C^{H,N_{Y/X}}, \nabla_B^{TX} D^{H,N_{Y/X}} \rangle \right),$$

which coincides with (1.34).

Using Theorem 1.9, we get

$$(1.41) \quad \begin{aligned} P^{TY} T^V(B, C^{H,V}) &= P^{TY} \left(-\nabla_{C^{H,V}}^{TX} B - [B, C^{H,V}] \right) \\ &= P^{TY} \left(-\nabla_{C^{H,W}}^{TX} B + \nabla_{C^{H,N_{Y/X}}}^{TX} B - [B, C^{H,W}] + [B, C^{H,N_{Y/X}}] \right) \\ &= -\nabla_{C^{H,W}}^{TY} B - [B, C^{H,W}] + P^{TY} \nabla_B^{TX} C^{H,N_{Y/X}} \\ &= T^W(B, C^{H,W}) + A(B)C^{H,N_{Y/X}}, \end{aligned}$$

which is the first identity in (1.35).

Now we use the notation of Section 1.1. By (1.2), (1.3), we get

$$(1.42) \quad \nabla_B^{N_{Y/X}} C^{H,N_{Y/X}} = P^{N_{Y/X}} \nabla_B^{TX} C^{H,N_{Y/X}} = P^{N_{Y/X}} \nabla_B^{TV} C^{H,W}.$$

Also

$$(1.43) \quad \nabla_B^{TV} C^{H,W} = \nabla_{C^{H,W}}^{TX} B + [B, C^{H,W}] + T^V(B, C^{H,W}).$$

Since $[B, C^{H,W}] \in TY$, we deduce from (1.42), (1.43) that

$$(1.44) \quad P^{N_{Y/X}} \nabla_B^{N_{Y/X}} C^{H,N_{Y/X}} = P^{N_{Y/X}} T^V(B, C^{H,W}) + A(C^{H,W})B,$$

which is the second identity in (1.35).

The proof of our Theorem is completed. \square

Let f_1, \dots, f_m be a locally defined smooth basis of TB , let f^1, \dots, f^m be the corresponding dual basis of T^*B .

Theorem 1.11 — *The following identity of tensors holds on W*

$$(1.45) \quad f^\alpha \wedge f^\beta \wedge f^\gamma \left\{ \left\langle f_\beta^{H,N_{Y/X}}, \nabla_{f_\alpha^{H,W}}^{TX} f_\gamma^{H,N_{Y/X}} \right\rangle + \frac{1}{2} \left\langle f_\alpha^{H,N_{Y/X}}, T^V \left(f_\beta^{H,V}, f_\gamma^{H,V} \right) + [f_\beta, f_\gamma]^{H,N_{Y/X}} \right\rangle \right\} = 0.$$

Moreover, if $B \in TY$, then the following identities of tensors holds on W

$$(1.46) \quad f^\alpha \wedge f^\beta \left\{ -\frac{1}{2} \left\langle T^V \left(f_\alpha^{H,V}, f_\beta^{H,V} \right), B \right\rangle - \left\langle f_\alpha^{H,N_{Y/X}}, \nabla_B^{TX} f_\beta^{H,N_{Y/X}} \right\rangle \right. \\ \left. + 2 \left\langle \nabla_{f_\alpha^{H,W}}^{TX} f_\beta^{H,N_{Y/X}}, B \right\rangle + \frac{1}{2} \left\langle T^W \left(f_\alpha^{H,W}, f_\beta^{H,W} \right), B \right\rangle \right\} = 0.$$

Proof. In the sequel, g^{TS} denotes an Euclidean metric on TS . Also we use the notation of Section 1.1. Clearly

$$(1.47) \quad \nabla_{f_\alpha^{H,W}}^{TX} f_\gamma^{H,N_{Y/X}} = \nabla_{f_\alpha^{H,W}}^{TV} f_\gamma^{H,W} - \nabla_{f_\alpha^{H,W}}^{TV} f_\gamma^{H,V} \\ = \nabla_{f_\alpha^{H,W}}^{TV} f_\gamma^{H,W} - \nabla_{f_\alpha^{H,V}}^{TV} f_\gamma^{H,V}.$$

Using (1.47), we get

$$(1.48) \quad \nabla_{f_\alpha^{H,W}}^{TX} f_\gamma^{H,N_{Y/X}} - \nabla_{f_\gamma^{H,W}}^{TX} f_\alpha^{H,N_{Y/X}} \\ = [f_\alpha^{H,W}, f_\gamma^{H,W}] + T^V(f_\alpha^{H,W}, f_\gamma^{H,W}) - [f_\alpha^{H,V}, f_\gamma^{H,V}] - T^V(f_\alpha^{H,V}, f_\gamma^{H,V}).$$

Also, by Theorem 1.1,

$$(1.49) \quad [f_\alpha^{H,W}, f_\gamma^{H,W}] = [f_\alpha, f_\gamma]^{H,W} - T^W(f_\alpha^{H,W}, f_\gamma^{H,W}), \\ [f_\alpha^{H,V}, f_\gamma^{H,V}] = [f_\alpha, f_\gamma]^{H,V} - T^V(f_\alpha^{H,V}, f_\gamma^{H,V}).$$

Using the fact that $T^W(f_\alpha^{H,W}, f_\gamma^{H,W}) \in TY$, we deduce from (1.48), (1.49) that

$$(1.50) \quad f^\alpha \wedge f^\beta \wedge f^\gamma \left\langle f_\beta^{H,N_{Y/X}}, \nabla_{f_\alpha^{H,W}}^{TX} f_\gamma^{H,N_{Y/X}} \right\rangle = \\ f^\alpha \wedge f^\beta \wedge f^\gamma \frac{1}{2} \left(\left\langle f_\beta^{H,N_{Y/X}}, T^V(f_\alpha^{H,W}, f_\gamma^{H,W}) + [f_\alpha, f_\gamma]^{H,N_{Y/X}} \right\rangle \right).$$

Also

$$(1.51) \quad f^\alpha \wedge f^\beta \wedge f^\gamma \left\langle f_\beta^{H,N_{Y/X}}, T^V(f_\alpha^{H,W}, f_\gamma^{H,W}) \right\rangle = \\ f^\alpha \wedge f^\beta \wedge f^\gamma \left\langle f_\beta^{H,N_{Y/X}}, T^V(f_\alpha^{H,V} + f_\alpha^{H,N_{Y/X}}, f_\gamma^{H,V} + f_\gamma^{H,N_{Y/X}}) \right\rangle.$$

By (1.6), (1.50)-(1.51), we get

$$(1.52) \quad f^\alpha \wedge f^\beta \wedge f^\gamma \left\langle f_\beta^{H,N_{Y/X}}, \nabla_{f_\alpha^{H,W}}^{TX} f_\gamma^{H,N_{Y/X}} \right\rangle = \\ f^\alpha \wedge f^\beta \wedge f^\gamma \frac{1}{2} \left(\left\langle f_\beta^{H,N_{Y/X}}, T^V(f_\alpha^{H,V}, f_\gamma^{H,V}) + [f_\alpha, f_\gamma]^{H,N_{Y/X}} \right\rangle \right),$$

which is exactly the identity (1.45).

Take $B \in TY, C \in TS, D \in TS$. Then using Theorem 1.10, we get

$$\begin{aligned}
 (1.53) \quad \langle \nabla_{C^H, W}^{TX} D^{H, N_{Y/X}}, B \rangle &= \langle A(C^{H, W}) D^{H, N_{Y/X}}, B \rangle \\
 &= -\langle A(C^{H, W}) B, D^{H, N_{Y/X}} \rangle \\
 &= -\langle \nabla_B^{TX} C^{H, N_{Y/X}}, D^{H, N_{Y/X}} \rangle \\
 &\quad + \langle T^V(B, C^{H, V}), D^{H, N_{Y/X}} \rangle.
 \end{aligned}$$

From (1.5), (1.53) and from Theorem 1.10, we obtain

$$\begin{aligned}
 (1.54) \quad \langle \nabla_{C^H, W}^{TX} D^{H, N_{Y/X}} - \nabla_{D^H, W}^{TX} C^{H, N_{Y/X}}, B \rangle & \\
 &\quad + \frac{1}{2} \langle \nabla_B^{TX} C^{H, N_{Y/X}}, D^{H, N_{Y/X}} \rangle \\
 &\quad - \frac{1}{2} \langle C^{H, N_{Y/X}}, \nabla_B^{TX} D^{H, N_{Y/X}} \rangle - \frac{1}{2} \langle T^V(C^{H, V}, D^{H, V}), B \rangle \\
 &\quad + \frac{1}{2} \langle T^W(C^{H, W}, D^{H, W}), B \rangle \\
 &= -\frac{1}{2} \langle \nabla_B^{TX} C^{H, N_{Y/X}}, D^{H, N_{Y/X}} \rangle + \frac{1}{2} \langle C^{H, N_{Y/X}}, \nabla_B^{TX} D^{H, N_{Y/X}} \rangle \\
 &\quad - \langle S^V(B) C^{H, V}, D^{H, N_{Y/X}} \rangle + \langle S^V(B) D^{H, V}, C^{H, N_{Y/X}} \rangle \\
 &\quad - \langle S^V(B) C^{H, V}, D^{H, V} \rangle + \langle S^W(B) C^{H, W}, D^{H, W} \rangle \\
 &\quad = -\frac{1}{2} \langle \nabla_B^{TX} C^{H, N_{Y/X}}, D^{H, N_{Y/X}} \rangle \\
 &\quad + \frac{1}{2} \langle C^{H, N_{Y/X}}, \nabla_B^{TX} D^{H, N_{Y/X}} \rangle \\
 &\quad - \langle S^V(B) C^{H, W}, D^{H, W} \rangle + \langle S^W(B) C^{H, W}, D^{H, W} \rangle = 0,
 \end{aligned}$$

which is equivalent to (1.46).

The proof of Theorem 1.10 is completed. □

2. Kähler fibrations, higher analytic torsion forms and anomaly formulas

In this Chapter, we recall various differential geometric properties of Kähler fibrations $\pi: V \rightarrow S$ [14]. Also we explain the local families index theorem of [4] in this context, we recall the construction in [14], [18] of analytic torsion forms, and we explain the anomaly formulas of [18].

This Chapter is organized as follows. In Section 2.1, we introduce the Kähler fibrations. In Section 2.2, we recall elementary results on Clifford algebras and complex vector spaces. In Section 2.3, we introduce the Levi-Civita superconnection of a fibration [4] and we state some of its properties established in [14]. In Section 2.4, we describe the superconnection forms of [4] and [14], which depend on $u \in]0, +\infty[$, and the corresponding transgression formulas. In Sections 2.5 and 2.6, we recall the results of [4], [14], [3] on the asymptotics of these forms as $u \rightarrow 0$ and $u \rightarrow +\infty$. In Section 2.7, we construct the analytic torsion forms of [14], [18]. Finally in Section 2.8, we give the anomaly formulas of [18].

In this Section, we use the notation of Chapter 1.

2.1 Kähler fibrations

Let $\pi: V \rightarrow S$ be a holomorphic submersion of complex manifolds, with compact fibres X .

We use the notation of Section 1.1, except that now $TV, TS, TX = TV/S$ denote the corresponding holomorphic tangent bundles, and $T_{\mathbf{R}}V, T_{\mathbf{R}}S, T_{\mathbf{R}}X = T_{\mathbf{R}}V/S$ the associated real tangent bundles.

Let J^{TX} be the complex structure on $T_{\mathbf{R}}X$. Let $T^H V$ be a smooth subbundle of TV such that we have the smooth splitting

$$(2.1) \quad TV = T^H V \oplus TX.$$

Let g^{TX} be a Hermitian metric on TX .

We recall the definition of a Kähler fibration, given in [14, Definition 1.4].

Definition 2.1. The triple $(\pi, g^{TX}, T^H V)$ is said to define a Kähler fibration if there exists a smooth real 2-form ω of complex type $(1, 1)$ over V which has the following properties :

- a) ω is closed.
- b) $T_{\mathbf{R}}^H V$ and $T_{\mathbf{R}}^H X$ are orthogonal with respect to ω .
- c) If $A, B \in T_{\mathbf{R}}^H X$

$$(2.2) \quad \omega(A, B) = \langle A, J^{TX} B \rangle_{g^{TX}} .$$

Let us now recall a simple result from [14, Theorems 1.5 and 1.7].

Theorem 2.2 — *Let ω be a real smooth 2-form on V of complex type $(1, 1)$, which has the following 2 properties :*

- a) ω is closed.
- b) *The bilinear map $A, B \in T_{\mathbf{R}}^H X \rightarrow \omega(J^{TX} A, B) \in \mathbf{R}$ defines a Hermitian metric g^{TX} on X .*

For $x \in V$, set

$$(2.3) \quad T_x^H V = \{A \in T_x V, \text{ for any } B \in T_x X, \omega_x(A, \bar{B}) = 0\} .$$

Then $T^H V$ is a subbundle of TV such that $TV = T^H V \oplus TX$. Also $(\pi, g^{TX}, T^H V)$ is a Kähler fibration, and ω is an associated $(1, 1)$ form.

A smooth real $(1, 1)$ form ω' on V is associated to $(\pi, g^{TX}, T^H V)$ if and only if there is a real smooth closed $(1, 1)$ form η on S such that

$$(2.4) \quad \omega' - \omega = \pi^* \eta .$$

Under the assumptions of Theorem 2.2, let ω^{TX} , ω^H the restriction of ω to $T_{\mathbf{R}} X$, $T_{\mathbf{R}}^H V$ so that

$$(2.5) \quad \omega = \omega^{TX} + \omega^H .$$

Let $\nabla^{T_{\mathbf{R}} X}$ be the connection on $(T_{\mathbf{R}} X, g^{T_{\mathbf{R}} X})$ constructed in Theorem 1.1, which is associated to $(\pi, g^{T_{\mathbf{R}} X}, T_{\mathbf{R}}^H V)$. Let $\nabla^{\Lambda(T_{\mathbf{R}}^* X)}$ be the connection induced by $\nabla^{T_{\mathbf{R}} X}$ on $\Lambda(T_{\mathbf{R}}^* X)$. Since $T_{\mathbf{R}} V = T_{\mathbf{R}}^H V \oplus T_{\mathbf{R}} X$, there is an associated identification

$$(2.6) \quad \Lambda(T_{\mathbf{R}}^* V) = \pi^* \Lambda(T_{\mathbf{R}} S) \hat{\otimes} \Lambda(T_{\mathbf{R}}^* X) .$$

Let ${}^a \nabla$ be the obvious action of $\nabla^{\Lambda(T_{\mathbf{R}}^* X)}$ on smooth sections of $\Lambda(T_{\mathbf{R}}^* V)$, so that if α, β are smooth sections of $\Lambda(T_{\mathbf{R}}^* S)$, $\Lambda(T_{\mathbf{R}}^* V)$, then

$$(2.7) \quad {}^a \nabla((\pi^* \alpha) \beta) = (\pi^* d\alpha) \beta + (-1)^{\deg \alpha} \pi^* \alpha \wedge \nabla^{\Lambda(T_{\mathbf{R}}^* X)} \beta .$$

Theorem 2.3 — Assume that $(\pi, g^{TX}, T^H V)$ is a Kähler fibration, and let ω be an associated $(1, 1)$ form. Then :

- a) The connection $\nabla^{T_{\mathbf{R}}X}$ on $T_{\mathbf{R}}X$ constructed in Theorem 1.1 preserves the complex structure of $T_{\mathbf{R}}X$. It induces the holomorphic Hermitian connection ∇^{TX} on (TX, g^{TX}) .
- b) As a 2-form, T is of complex type $(1, 1)$. Also if $A \in T^H V$, $B \in \overline{TX}$ (resp. $A \in \overline{T^H V}$, $B \in TX$), then $T(A, B) \in TX$ (resp. \overline{TX}).
- c) For any $A \in T_{\mathbf{R}}X$, the 2-form $\langle S(A), \cdot, \cdot \rangle$ on V is of complex type $(1, 1)$. Also if $A \in TX$, $B \in \overline{TX}$

$$(2.8) \quad S(A)B = 0 \quad , \quad S(B)A = 0.$$

d) The following identities hold

$$(2.9) \quad \left\{ \begin{array}{l} \text{for any } A \in T_{\mathbf{R}}S, L_{A^H} \omega^{TX} = 0, \\ \nabla^{TX} \omega^{TX} = 0; i_T^{TX} \omega^{TX} = 0 \text{ on } T_{\mathbf{R}}^H V \times T_{\mathbf{R}}X \times T_{\mathbf{R}}X, \\ {}^a \nabla \omega^H = 0 \text{ on } T_{\mathbf{R}}^H V \times T_{\mathbf{R}}^H V \times T_{\mathbf{R}}^H V, \\ {}^a \nabla \omega^H + i_T \omega^{TX} = 0 \text{ on } T_{\mathbf{R}}^H V \times T_{\mathbf{R}}^H V \times T_{\mathbf{R}}X. \end{array} \right.$$

Proof. Only the second part of b) is not explicitly proved in [14, Theorem 1.7]. However if $A \in T_{\mathbf{R}}^H V$, $B \in T_{\mathbf{R}}X$, by (1.5),

$$(2.10) \quad T(A, B) = P^{TX} S(B)A.$$

Since $\langle S(B), \cdot, \cdot \rangle$ is of complex type $(1, 1)$, $T(A, B)$ is of the same complex type as A .

Our Theorem is proved. □

Remark 2.4. The second identity in the second row of (2.9) is also a consequence of the fact that T is of type $(1, 1)$ and also of (1.6). The last identity in (2.9) says that if $A, B \in T_{\mathbf{R}}S$, $\omega^H(A^H, B^H)$ is a Hamiltonian function whose corresponding Hamiltonian vector field in $T_{\mathbf{R}}X$ with respect to the fibrewise symplectic form ω^{TX} is $T(A^H, B^H)$.

In [14, proof of Theorem 1.14], as a consequence of (2.8), it is shown that if $e_1, \dots, e_{2\ell}$ is an orthonormal basis of $T_{\mathbf{R}}X$,

$$(2.11) \quad \sum_1^{2\ell} S(e_i) e_i = 0.$$

Consider the exact sequence

$$(2.12) \quad 0 \rightarrow TX \rightarrow TV \rightarrow \pi^* TS \rightarrow 0.$$

By identifying π^*TS and $T^H V$, let $E \in T^{*(0,1)}V \otimes \text{Hom}(T^H V, TX)$ be the extension which defines the holomorphic structure on TV .

We extend E to a skew-adjoint section of $T_{\mathbf{R}}^*V \otimes \text{End}(T_{\mathbf{R}}V)$, which exchanges $T_{\mathbf{R}}X$ and $T_{\mathbf{R}}^H V$.

Theorem 2.5 — *If $A \in T_{\mathbf{R}}^H V$, $B \in T_{\mathbf{R}}X$, then*

$$(2.13) \quad E(B)A = T(A, B).$$

Proof. Clearly the statement (2.13) is local on the base S . So we may as well assume that S is Kähler. Let ω^S be the Kähler form of a Kähler metric g^{TS} on TS . Replacing ω by $\omega + \frac{1}{\varepsilon}\pi^*\omega^S$, which does not modify $T^H V$ or g^{TX} , we may assume that V is Kähler, and that ω is the Kähler form of a Kähler metric g^{TV} on TV . Then the Levi-Civita connection $\nabla^{TV, L}$ on $(T_{\mathbf{R}}V, g^{T_{\mathbf{R}}V})$ induces the corresponding holomorphic Hermitian connection on (TV, g^{TV}) . By Theorem 1.2, if A is a smooth section of $T_{\mathbf{R}}^H V$ and if B, C are smooth sections of $T_{\mathbf{R}}X$, we get

$$(2.14) \quad \left\langle \nabla_B^{TV, L} A, C \right\rangle - \left\langle \nabla_B^{TV, L} C, A \right\rangle = 2 \left\langle S^V(B)A, C \right\rangle.$$

From (2.14), we obtain

$$(2.15) \quad \langle E(B)A, C \rangle = \langle S^V(B)A, C \rangle.$$

Using (1.5), (2.15), we get

$$(2.16) \quad \langle E(B)A, C \rangle = \langle T(A, B), C \rangle,$$

which gives (2.13). □

Remark 2.6. Of course (2.13) gives an essentially equivalent proof of most of the properties of T stated in part b) of Theorem 2.3.

2.2 Complex Hermitian vector spaces and Clifford algebras

Let E be a complex Hermitian vector space. Let \bar{E} be the conjugate vector space. If $z \in E$, z represents $Z = z + \bar{z} \in E_{\mathbf{R}}$, and $|Z|^2 = 2|z|^2$.

Let $c(E_{\mathbf{R}})$ be the Clifford algebra of $E_{\mathbf{R}}$, i.e. the algebra generated by 1, $U \in E_{\mathbf{R}}$, with the commutation relation $UU' + U'U = -2\langle U, U' \rangle$. Then $\Lambda(\bar{E}^*)$ and $\Lambda(E^*)$ are Clifford modules. Namely, if $X \in E$, $X' \in \bar{E}$, let $X^* \in \bar{E}^*$, $X'^* \in E^*$ correspond to X , X' by the metric. Set

$$(2.17) \quad \begin{aligned} c(X) &= \sqrt{2}X^* \wedge, \quad c(X') = -\sqrt{2}i_{X'}, \\ \widehat{c}(X) &= \sqrt{2}i_X, \quad \widehat{c}(X') = -\sqrt{2}X'^* \wedge. \end{aligned}$$

Then if $U, U' \in E_{\mathbf{R}}$,

$$(2.18) \quad \begin{aligned} c(U)c(U') + c(U')c(U) &= -2 \langle U, U' \rangle, \\ \widehat{c}(U)\widehat{c}(U') + \widehat{c}(U')\widehat{c}(U) &= -2 \langle U, U' \rangle. \end{aligned}$$

Also $c(U), \widehat{c}(U')$ acts as odd operators on $\Lambda(\overline{E}^*) \widehat{\otimes} \Lambda(E^*)$, and

$$(2.19) \quad c(U)\widehat{c}(U') + \widehat{c}(U')c(U) = 0.$$

Let J be the complex structure of $E_{\mathbf{R}}$. Note that with respect to [19, Section 5 a)], our $\widehat{c}(U)$ would be $\widehat{c}(JU)$ in [19].

2.3 The Levi-Civita superconnection of the fibration

The metric g^{TX} induces a metric $g^{\Lambda(T^{*(0,1)}X)}$ on $\Lambda(T^{*(0,1)}X)$, and the connection ∇^{TX} lifts to a unitary connection $\nabla^{\Lambda(T^{*(0,1)}X)}$ on $\Lambda(T^{*(0,1)}X)$.

Let ξ be a holomorphic vector bundle on V , let g^ξ be a Hermitian metric on ξ . Let ∇^ξ be the holomorphic Hermitian connection on (ξ, g^ξ) .

We equip $\Lambda(T^{*(0,1)}X) \otimes \xi$ with the tensor product of the metrics $g^{\Lambda(T^{*(0,1)}X)}$ and g^ξ . Set

$$(2.20) \quad \nabla^{\Lambda(T^{*(0,1)}X) \otimes \xi} = \nabla^{\Lambda(T^{*(0,1)}X)} \otimes 1 + 1 \otimes \nabla^\xi.$$

Then $\nabla^{\Lambda(T^{*(0,1)}X) \otimes \xi}$ is a unitary connection on $\Lambda(T^{*(0,1)}X) \otimes \xi$.

Definition 2.7. For $0 \leq p \leq \dim X$, $s \in S$, let E_s^p be the vector space of smooth sections of $(\Lambda^p(T^{*(0,1)}X) \otimes \xi)|_{X_s}$ over the fibre X_s . Set

$$(2.21) \quad E_s = \bigoplus_{p=0}^{\dim X} E_s^p, \quad E_{s,+} = \bigoplus_{p \text{ even}} E_s^p, \quad E_{s,-} = \bigoplus_{p \text{ odd}} E_s^p.$$

We regard the E_s 's as the fibres of a smooth \mathbf{Z} -graded infinite dimensional vector bundle over S . Smooth sections of E over S will be identified to smooth sections of $\Lambda(T^{*(0,1)}X) \otimes \xi$ over V .

Let $*^{TX}$ be the star operator acting on $\Lambda(T_{\mathbf{R}}^*X)$, associated to g^{TX} . We equip E_s with the Hermitian product

$$(2.22) \quad \alpha, \alpha' \in E_s \rightarrow \langle \alpha, \alpha' \rangle_{E_s} = \frac{1}{(2\pi)^{\dim X}} \int_{X_s} \langle \alpha \wedge *^{TX} \alpha' \rangle_{g^\xi}.$$

Let dv_{X_s} be the volume element in the fibre X_s . Then if $\alpha, \alpha' \in E_s$,

$$(2.23) \quad \langle \alpha, \alpha' \rangle_{E_s} = \left(\frac{1}{2\pi} \right)^{\dim X} \int_{X_s} \langle \alpha, \alpha' \rangle_{g^{\Lambda T^{*(0,1)}X} \otimes g^\xi} dv_{X_s}.$$

Definition 2.8. If $U \in T_{\mathbf{R}}B$, if s is a smooth section of E over S , set

$$(2.24) \quad \nabla_U^E s = \nabla_{UH}^{\Lambda T^{*(0,1)}X \otimes \xi} s.$$

Clearly, ∇^E is a connection on E . Let $\nabla^{E'}$ and $\nabla^{E''}$ be the holomorphic and antiholomorphic parts of ∇^E .

For $s \in S$, let $\bar{\partial}^{X_s}$ be the Dolbeault operator acting on E_s , and let $\bar{\partial}^{X_s^*}$ be its formal adjoint with respect to the Hermitian product (2.22).

The following result is proved in [14, Theorem 1.14].

Theorem 2.9 — *The connection ∇^E preserves the Hermitian product (2.22) on E . Its curvature $\nabla^{E,2}$ is of complex type $(1, 1)$. Also*

$$(2.25) \quad [\nabla^{E''}, \bar{\partial}^X] = 0, \quad [\nabla^{E'}, \bar{\partial}^{X^*}] = 0.$$

By (2.1), we have the identification of \mathbf{Z} -graded vector bundles

$$(2.26) \quad \Lambda(T^{*(0,1)}V) \otimes \xi = \pi^* \Lambda(T^{*(0,1)}S) \hat{\otimes} \Lambda(T^{*(0,1)}X) \otimes \xi.$$

Let $\bar{\partial}^V$ be the Dolbeault operator acting on the vector space of smooth sections of $\Lambda(T^{*(0,1)}V) \otimes \xi$ over V . By (2.24), (2.26), the operator $\nabla^{E''} + \bar{\partial}^X$ also acts naturally on this vector space.

The following result is established in [14, Theorem 2.8].

Theorem 2.10 — *We have the following identity of operators acting on smooth sections of $\Lambda(T^{*(0,1)}V) \otimes \xi$ over V ,*

$$(2.27) \quad \bar{\partial}^V = \nabla^{E''} + \bar{\partial}^X.$$

Definition 2.11. Set

$$(2.28) \quad c(T) = \frac{1}{2} f^\alpha f^\beta c(T(f_\alpha^H, f_\beta^H)).$$

Then $c(T)$ is a section of $\pi^* \Lambda(T_{\mathbf{R}}^* S) \hat{\otimes} \text{End}(\Lambda(T^{*(0,1)}X) \otimes \xi)$. We also define $c(T^{(1,0)})$, $c(T^{(0,1)})$ by formulas similar to (2.28). By (2.17),

$$(2.29) \quad \frac{c(T^{(1,0)})}{\sqrt{2}} = T^{(1,0)*} \wedge, \quad \frac{c(T^{(0,1)})}{\sqrt{2}} = -i_{T^{(0,1)}}.$$

By [14, eq. (1.41) and Theorem 2.6]

$$(2.30) \quad \begin{aligned} \frac{c(T^{(1,0)})}{\sqrt{2}} &= -i \left[\bar{\partial}^X, \omega^H \right], \\ \frac{c(T^{(0,1)})}{\sqrt{2}} &= i \left[\bar{\partial}^{X^*}, \omega^H \right]. \end{aligned}$$

Definition 2.12. For $u > 0$, set

$$\begin{aligned}
 (2.31) \quad B''_u &= \sqrt{u} \bar{\partial}^X + \nabla^{E''} - \frac{c(T^{(1,0)})}{2\sqrt{2u}}, \\
 B'_u &= \sqrt{u} \bar{\partial}^{X*} + \nabla^{E'} - \frac{c(T^{(0,1)})}{2\sqrt{2u}}, \\
 B_u &= \sqrt{u} (\bar{\partial}^X + \bar{\partial}^{X*}) + \nabla^E - \frac{c(T)}{2\sqrt{2u}}.
 \end{aligned}$$

Then $B_u = B''_u + B'_u$ is a superconnection on E in the sense of Quillen [32]. By [14, Section 2], B_u is exactly the Levi-Civita superconnection of the fibration in the sense of [4, Section 3].

Let $N_{\mathbf{V}}$ be the operator defining the \mathbf{Z} -grading on E , i.e. $N_{\mathbf{V}}$ acts by multiplication by p on E^p .

Definition 2.13. Set

$$(2.32) \quad N_u = N_{\mathbf{V}} + \frac{i\omega^H}{u}.$$

Then N_u is a section of $\pi^* \Lambda(T_{\mathbf{R}}^* S) \widehat{\otimes} \text{End}(\Lambda(T^{*(0,1)} X) \otimes \xi)$.

The following result is proved in [14, Theorem 2.6].

Theorem 2.14 — *The following identities hold,*

$$\begin{aligned}
 (2.33) \quad B_u'^2 &= 0, \quad B_u''^2 = 0, \\
 B_u^2 &= [B'_u, B''_u], \\
 [B''_u, B_u^2] &= 0, \quad [B'_u, B_u^2] = 0, \\
 [B''_u, N_u] &= -2u \frac{\partial}{\partial u} B''_u, \quad [B'_u, N_u] = 2u \frac{\partial}{\partial u} B'_u.
 \end{aligned}$$

By (2.9), we get

$$(2.34) \quad [\nabla^{E''}, \omega^H] = 0, \quad [\nabla^{E'}, \omega^H] = 0.$$

From (2.30), (2.31), (2.34), we get the formulas

$$\begin{aligned}
 (2.35) \quad B''_u &= e^{-\frac{i\omega^H}{2u}} u^{N_{\mathbf{V}}/2} \left(\nabla^{E''} + \bar{\partial}^X \right) u^{-\frac{N_{\mathbf{V}}}{2}} e^{\frac{i\omega^H}{2u}}, \\
 B'_u &= e^{\frac{i\omega^H}{2u}} u^{-N_{\mathbf{V}}/2} \left(\nabla^{E'} + \bar{\partial}^{X*} \right) u^{N_{\mathbf{V}}/2} e^{-\frac{i\omega^H}{2u}}.
 \end{aligned}$$

2.4 Superconnection forms and transgression formulas

Definition 2.15. Let P^S be the vector space of real forms on S which are sums of forms of type (p, p) . Let $P^{S,0}$ be the vector space of the forms $\alpha \in P^S$ such that there exist smooth forms β, γ on S with $\alpha = \bar{\partial}\beta + \partial\gamma$.

We define P^V , $P^{V,0}$ in the same way.

Let $\Phi: \Lambda^{\text{even}}(T_{\mathbf{R}}^*S) \rightarrow \Lambda^{\text{even}}(T_{\mathbf{R}}^*S)$ be the map $\alpha \rightarrow (2i\pi)^{-\deg \alpha/2} \alpha$.

If A is a square matrix, set

$$(2.36) \quad \begin{aligned} \text{Td}(A) &= \det \left(\frac{A}{1 - e^{-A}} \right), \\ \text{Td}'(A) &= \frac{\partial}{\partial b} \text{Td}(A + b)|_{b=0}, \\ (\text{Td}^{-1})'(A) &= \frac{\partial}{\partial b} \text{Td}^{-1}(A + b)|_{b=0}, \\ \text{ch}(A) &= \text{Tr}[\exp(A)]. \end{aligned}$$

The genera associated to Td and ch are the Todd genus and the Chern character.

Let P be a real ad-invariant power series on square matrices. If (F, g^F) is a holomorphic Hermitian vector bundle on V , let ∇^F be the corresponding holomorphic Hermitian connection, and let R^F be its curvature. Set

$$(2.37) \quad P(F, g^F) = P \left(-\frac{R^F}{2i\pi} \right).$$

Then $P(F, g^F)$ is a closed form which lies in P^V , and its cohomology class $P(F)$ does not depend on g^F . We still denote by $P(F)$ the classes of $P(F, g^F)$ in $P^S/P^{S,0}$.

By [4, Theorem 3.4], we know that the forms $\Phi \text{Tr}_s[\exp(-B_u^2)]$ are closed, and that their cohomology class is constant and equal to $\text{ch}(R\pi_*\xi)$.

By [14, Theorems 2.2 and 2.9], the forms $\Phi \text{Tr}_s[\exp(-B_u^2)]$ and $\Phi \text{Tr}_s[N_u \exp(-B_u^2)]$ lie in P^S . The following result is established in [14, Theorem 2.9].

Theorem 2.16 — *For $u > 0$, the following identity holds*

$$(2.38) \quad \frac{\partial}{\partial u} \Phi \text{Tr}_s[\exp(-B_u^2)] = -\frac{1}{u} \frac{\bar{\partial}\partial}{2i\pi} \Phi \text{Tr}_s[N_u \exp(-B_u^2)].$$

If $(\alpha_u)_{u>0}$ is a family of smooth forms on S , we will write that as $u \rightarrow 0$, $\alpha_u = \mathcal{O}(u^{k+1})$ if for any compact set $K \subset S$, and any $p \in \mathbf{N}$, there is $C > 0$ such that the sup of α_u and of its derivative of order $\leq p$ on K are dominated by Cu^{k+1} .

2.5 The asymptotics of the superconnection forms as $u \rightarrow 0$

Now we recall a result established in [4, Theorems 4.12 and 4.16] and in [14, Theorems 2.11 and 2.16].

Theorem 2.17 — *As $u \rightarrow 0$,*

$$(2.39) \quad \Phi \text{Tr}_s[\exp(-B_u^2)] = \int_X \text{Td}(TX, g^{TX}) \text{ch}(\xi, g^\xi) + \mathcal{O}(u).$$

There exist forms $C_{-1}, C_0, \dots, C_k, \dots \in P^S$ such that for $k \in \mathbf{N}$, as $u \rightarrow 0$,

$$(2.40) \quad \Phi \operatorname{Tr}_s [N_u \exp(-B_u^2)] = \sum_{-1}^k C_j u^j + \mathcal{O}(u^{k+1}).$$

Moreover

$$(2.41) \quad \begin{aligned} C_{-1} &= \int_X \frac{\omega}{2\pi} \operatorname{Td}(TX, g^{TX}) \operatorname{ch}(\xi, g^\xi), \\ C_0 &= \int_X (\dim X \operatorname{Td}(TX) - \operatorname{Td}'(TX)) \operatorname{ch}(\xi) \text{ in } P^S/P^{S,0}. \end{aligned}$$

2.6 The asymptotics of the superconnection forms as $u \rightarrow +\infty$

For $s \in S$, let $H(X_s, \xi|_{X_s}) = \bigoplus_0^{\dim X} H^p(X_s, \xi|_{X_s})$ be the cohomology of the sheaf of holomorphic sections of ξ restricted to X_s .

We make the basic assumption that for $0 \leq p \leq \dim X$, the dimension of $H^p(X_s, \xi|_{X_s})$ is locally constant. Then the $H(X_s, \xi|_{X_s})$'s are the fibres of a holomorphic \mathbf{Z} -graded vector bundle $H(X, \xi|_X)$ on S .

For $s \in S$, set

$$(2.42) \quad K_s = \left\{ f \in E_s, \bar{\partial}^{X_s} f = 0, \bar{\partial}^{X_s^*} f = 0 \right\}.$$

By Hodge theory, $K_s \simeq H(X_s, \xi|_{X_s})$. Since the $H^p(X_s, \xi|_{X_s})$ have locally constant dimension, the K_s 's are the fibres of a smooth \mathbf{Z} -graded vector bundle K on S , and moreover we have the identification of smooth vector bundles on S ,

$$(2.43) \quad H(X, \xi|_X) \simeq K.$$

As a subbundle of (E, g^E) , the vector bundle K inherits a smooth metric g^K . Let $g^{H(X, \xi|_X)}$ be the corresponding smooth metric on $H(X, \xi)$.

For $s \in S$, let P^{K_s} be the orthogonal projection operator from E_s on K_s . Then P^{K_s} depends smoothly on s .

Definition 2.18. Let ∇^K be the unitary connection on (K, g^K)

$$(2.44) \quad \nabla^K = P^K \nabla^E.$$

Using the identification (2.43), the connection ∇^K determines a unitary connection $\nabla^{H(X, \xi|_X)}$ on $H(X, \xi|_X)$.

We now have the following result in [18, Theorem 3.2].

Theorem 2.19 — *The connection $\nabla^{H(X, \xi|_X)}$ is exactly the holomorphic Hermitian connection on $(H(X, \xi|_X), g^{H(X, \xi|_X)})$. In particular, $\nabla^{H(X, \xi|_X)}$ only depends on the $(1, 1)$ -form ω via the metric g^{TX} on TX .*

Put

$$(2.45) \quad \text{ch}(H(X, \xi|_X), g^{H(X, \xi|_X)}) = \sum_{i=0}^{\dim X} (-1)^i \text{ch}(H^i(X, \xi|_X), g^{H^i(X, \xi|_X)}).$$

The operator $N_{\mathbf{V}}$ induces the obvious \mathbf{Z} -grading on $H(X, \xi|_X)$.

By definition $\nabla^{H(X, \xi|_X), 2}$ is the curvature of $\nabla^{H(X, \xi|_X)}$. Also as $u \rightarrow +\infty$, we use the same notation as for $u \rightarrow 0$. We recall a result of Berline-Getzler-Vergne [3, Theorem 9.19], also recalled in [18, Theorem 3.4].

Theorem 2.20 — As $u \rightarrow +\infty$,

$$(2.46) \quad \begin{aligned} \Phi \text{Tr}_s [\exp(-B_u^2)] &= \Phi \text{Tr}_s [\exp(-\nabla^{H(X, \xi|_X), 2})] + \mathcal{O}\left(\frac{1}{\sqrt{u}}\right), \\ \Phi \text{Tr}_s [N_u \exp(-B_u^2)] &= \Phi \text{Tr}_s [N_{\mathbf{V}} \exp(-\nabla^{H(X, \xi|_X), 2})] + \mathcal{O}\left(\frac{1}{\sqrt{u}}\right). \end{aligned}$$

2.7 Higher analytic torsion forms

For $s \in \mathbf{C}$, $\text{Re}(s) > 1$, set

$$(2.47) \quad \zeta^1(s) = -\frac{1}{\Gamma(s)} \int_0^1 u^{s-1} \Phi \left(\text{Tr}_s [N_u \exp(-B_u^2)] - \text{Tr}_s [N_{\mathbf{V}} \exp(-\nabla^{H(X, \xi|_X), 2})] \right) du.$$

In view of (2.40), it is clear that $\zeta^1(s)$ extends to a meromorphic function of $s \in \mathbf{C}$, which is holomorphic for $|\text{Re}(s)| < \frac{1}{2}$.

Similarly, if $s \in \mathbf{C}$, $\text{Re}(s) < \frac{1}{2}$, we define $\zeta^2(s)$ as in (2.37), replacing \int_0^1 by $\int_1^{+\infty}$. In view of Theorem 2.20, it is clear that $\zeta^2(s)$ is a holomorphic function of $s \in \mathbf{C}$, $\text{Re}(s) < \frac{1}{2}$.

Definition 2.21. For $s \in \mathbf{C}$, $|\text{Re}(s)| < \frac{1}{2}$, set

$$(2.48) \quad \zeta(s) = \zeta^1(s) + \zeta^2(s).$$

Then $\zeta(s)$ is holomorphic on its domain of definition.

Definition 2.22. Set

$$(2.49) \quad T(\omega, g^\xi) = \frac{\partial}{\partial s} \zeta(0).$$

Observe that the component of degree 0 of $T(\omega, g^\xi)$ is exactly the Ray-Singer analytic torsion [34] of the complex $(E, \bar{\partial}^X)$. By analogy, the forms $T(\omega, g^\xi)$ are called higher analytic torsion forms.

By (2.40),

$$(2.50) \quad T(\omega, g^\xi) = - \int_0^1 \left(\Phi \operatorname{Tr}_s [N_u \exp(-B_u^2)] - \frac{C_{-1}}{u} - C_0 \right) \frac{du}{u} \\ - \int_1^{+\infty} \Phi \left(\operatorname{Tr}_s [N_u \exp(-B_u^2)] - \operatorname{Tr}_s [N_{\mathbf{V}} \exp(-\nabla^{H(X, \xi|_X), 2})] \right) \frac{du}{u} \\ + C_{-1} + \Gamma'(1) \left(C_0 - \varphi \operatorname{Tr}_s [N_{\mathbf{V}} \exp(-\nabla^{H(X, \xi|_X), 2})] \right).$$

We recall the result of [14, Theorem 2.20], [18, Theorem 3.9].

Theorem 2.23 — *The C^∞ form $T(\omega, g^\xi)$ on S lies in P^S . Moreover*

$$(2.51) \quad \frac{\bar{\partial}\partial}{2i\pi} T(\omega, g^\xi) = \operatorname{ch} \left(H(X, \xi|_X), g^{H(X, \xi|_X)} \right) - \int_X \operatorname{Td}(TX, g^{TX}) \operatorname{ch}(\xi, g^\xi).$$

2.8 Anomaly formulas for the analytic torsion forms

Let now (ω', g'^ξ) be another couple of objects similar to (ω, g^ξ) . We denote with a ' the objects associated to (ω', g'^ξ) .

Let $\widetilde{\operatorname{Td}}(TX, g^{TX}, g'^{TX}) \in P^V/P^{V,0}$, $\widetilde{\operatorname{ch}}(\xi, g^\xi, g'^\xi) \in P^V/P^{V,0}$ be the Bott-Chern classes constructed in [13, Section 1f)], such that

$$(2.52) \quad \frac{\bar{\partial}\partial}{2i\pi} \widetilde{\operatorname{Td}}(TX, g^{TX}, g'^{TX}) = \operatorname{Td}(TX, g'^{TX}) - \operatorname{Td}(TX, g^{TX}), \\ \frac{\bar{\partial}\partial}{2i\pi} \widetilde{\operatorname{ch}}(\xi, g^\xi, g'^\xi) = \operatorname{ch}(\xi, g'^\xi) - \operatorname{ch}(\xi, g^\xi).$$

Similarly we construct the class $\widetilde{\operatorname{ch}}(H(X, \xi|_X), g^{H(X, \xi|_X)}, g'^{H(X, \xi|_X)}) \in P^S/P^{S,0}$.

Now we recall the anomaly formulas of Bismut-Köhler [18, Theorems 3.10 and 3.11], which extend in arbitrary degree the anomaly formulas for Quillen metrics of [13], [15].

Theorem 2.24 — *The following identity holds*

$$(2.53) \quad T(\omega', g'^\xi) - T(\omega, g^\xi) = \widetilde{\operatorname{ch}} \left(H(X, \xi|_X), g^{H(X, \xi|_X)}, g'^{H(X, \xi|_X)} \right) \\ - \int_Z \left(\widetilde{\operatorname{Td}}(TX, g^{TX}, g'^{TX}) \operatorname{ch}(\xi, g^\xi) + \operatorname{Td}(TX, g'^{TX}) \widetilde{\operatorname{ch}}(\xi, h^\xi, h'^\xi) \right) \\ \text{in } P^S/P^{S,0}.$$

In particular, the class of $T(\omega, g^\xi)$ in $P^S/P^{S,0}$ depends only on (g^{TX}, g^ξ) .

Remark 2.25. For the component of degree 0 of $T(\omega, g^\xi)$, the content of Theorems 2.23 and 2.24 is essentially equivalent to the curvature Theorem for Quillen metrics established in [13], [15].

3. Kähler fibrations, resolutions, and Bott-Chern currents

In this Chapter, we describe our basic geometric setting, i.e. the embedding $i: W \rightarrow V$, and the holomorphic submersion $\pi_V: V \rightarrow S$, $\pi_W: W \rightarrow S$. Also η denotes a holomorphic vector bundle on W , and (ξ, v) is a resolution of $i_*\eta$ by a complex of vector bundles on V . We make the basic assumption that $R\pi_{W*}\eta$ is locally free.

In this Chapter, we construct the analytic torsion norms of the family of double complexes $(E, \bar{\partial}^X + v)$ along the fibres X , and we describe the Bott-Chern currents of [16], [17].

This Chapter is organized as follows. In Section 3.1, we give our geometric setting. In Section 3.2, we construct the analytic torsion forms of the family of double complexes, and in Section 3.3, we describe the Bott-Chern currents of [16], [17].

3.1 A family of double complexes

Let $i: W \rightarrow V$ be an embedding of smooth complex manifolds. Let S be a complex manifold. Let $\pi|_V: V \rightarrow S$ be a holomorphic submersion with compact fibre X , whose restriction $\pi|_W: W \rightarrow S$ is a holomorphic submersion with compact fibre Y .

Then we have the diagram of holomorphic maps

$$(3.1) \quad \begin{array}{ccccc} Y & \longrightarrow & W & & \\ \downarrow i & & \downarrow i & \searrow \pi_W & \\ X & \longrightarrow & V & \xrightarrow{\pi_V} & S \end{array}$$

Let η be a holomorphic vector bundle on W . Let

$$(3.2) \quad (\xi, v): 0 \rightarrow \xi_m \xrightarrow{v} \xi_{m-1} \xrightarrow{v} \dots \xrightarrow{v} \xi_0 \rightarrow 0$$

be a holomorphic complex of vector bundles on V . We identify ξ with $\bigoplus_0^m \xi_i$. Let $r: \xi_0|_W \rightarrow \eta$ be a holomorphic restriction map. We make the assumption that (ξ, v)

is a resolution of $i_*\eta$, or equivalently that we have the exact sequence of \mathbb{C}_V sheaves

$$(3.3) \quad 0 \rightarrow \mathbb{C}_V(\xi_m) \xrightarrow{v} \mathbb{C}_V(\xi_{m-1}) \xrightarrow{v} \dots \rightarrow \mathbb{C}_V(\xi_0) \rightarrow i_*\mathbb{C}_W(\eta) \rightarrow 0.$$

Then for every $s \in S$, $(\xi, v)|_{X_s}$ provides a resolution of $i_*\eta|_{Y_s}$.

Definition 3.1. For $s \in S$, $0 \leq p \leq \dim X$, $0 \leq i \leq m$, let $E_{i,s}^p$ be the vector space of smooth sections of $(\Lambda(T^{*(0,1)}X) \otimes \xi_i)|_{X_s}$ on the fibre X_s . Set

$$(3.4) \quad \begin{aligned} E_{i,s}^+ &= \bigoplus_{p \text{ even}} E_{i,s}^p, & E_{i,s}^- &= \bigoplus_{p \text{ odd}} E_{i,s}^p, & E_{i,s} &= E_{i,s}^+ \oplus E_{i,s}^-, \\ E_{+,s} &= \bigoplus_{p-i \text{ even}} E_{i,s}^p, & E_{-,s} &= \bigoplus_{p-i \text{ odd}} E_{i,s}^p, & E_s &= E_{+,s} \oplus E_{-,s}. \end{aligned}$$

Then the objects in (3.4) are the fibres of infinite dimensional vector bundles on S .

The Dolbeault operator $\bar{\partial}^X$ acts fibrewise on E . Also the chain map v acts on ξ as an odd operator. We extend v to an odd operator acting on $\Lambda(T^{*(0,1)}X) \widehat{\otimes} \xi$, so that if $\alpha \in \Lambda^p(T^{*(0,1)}X)$, $f \in \xi$,

$$(3.5) \quad v(\alpha \widehat{\otimes} f) = (-1)^p \alpha \widehat{\otimes} v f.$$

Then we have the identities

$$\bar{\partial}^{X,2} = 0 \quad , \quad v^2 = 0 \quad , \quad \bar{\partial}^X v + v \bar{\partial}^X = 0,$$

and so

$$(3.6) \quad (\bar{\partial}^X + v)^2 = 0.$$

Let N_V^X, N_H be the operators acting on $\Lambda^p(T^{*(0,1)}X)$, ξ_i by multiplication by p, i . The operator $N_V^X - N_H$ acts naturally on E , and defines a \mathbf{Z} -grading on E , for which $\bar{\partial}^X + v$ increases the degree by 1, i.e. $\bar{\partial}^X + v$ is a chain map.

Definition 3.2. For $s \in S$, $0 \leq q \leq \dim Y$, let F_s^q be the vector space of smooth sections of $(\Lambda^q(T^{*(0,1)}Y) \otimes \eta)|_{Y_s}$ over Y_s . Set

$$(3.7) \quad F_{+,s} = \bigoplus_{q \text{ even}} F_s^q, \quad F_{-,s} = \bigoplus_{q \text{ odd}} F_s^q, \quad F_s = F_{+,s} \oplus F_{-,s}.$$

Again the objects in (3.7) are the fibres of corresponding infinite dimensional vector bundles over S . The Dolbeault operator $\bar{\partial}^Y$ acts fibrewise on F .

Let N_V^Y be the operator acting on $\Lambda^q(T^{*(0,1)}Y)$ by multiplication by q . Then N_V^Y acts naturally on F , and defines a \mathbf{Z} -grading for which $\bar{\partial}^Y$ increases the degree by 1.

Let $H(X_s, \xi|_{X_s})$ be the hypercohomology of $(\mathcal{O}_{X_s}(\xi|_{X_s}), v)$, let $H(Y_s, \eta|_{Y_s})$ be the cohomology of $\mathcal{O}_{Y_s}(\eta|_{Y_s})$. Then since (3.3) is exact, for any $s \in S$, the map $r: \mathcal{O}_{X_s}(\xi|_{X_s}) \rightarrow \mathcal{O}_{Y_s}(\eta|_{Y_s})$ is a quasi-isomorphism, and so

$$(3.8) \quad H(X_s, \xi|_{X_s}) \simeq H(Y_s, \eta|_{Y_s}).$$

By a result of Dolbeault and by [19, Proposition 1.5], for every $s \in S$,

$$(3.9) \quad \begin{aligned} H(E_s, \bar{\partial}^X + v) &\simeq H(X_s, \xi|_{X_s}), \\ H(F_s, \bar{\partial}^Y) &\simeq H(Y_s, \eta|_{Y_s}). \end{aligned}$$

We extend r to a morphism $\xi|_W \rightarrow \eta$, with $r = 0$ on ξ_i , $i > 0$. For $s \in S$, let r_s be the restriction map

$$(3.10) \quad r_s: \alpha \in E_s \rightarrow (i^* \widehat{\otimes} r)\alpha \in F_s.$$

Now we recall a result in [19, Theorem 1.7].

Theorem 3.3 — *For any $s \in S$, the map $r_s: (E_s, \bar{\partial}^X + v) \rightarrow (F_s, \bar{\partial}^Y)$ is a quasi-isomorphism of \mathbf{Z} -graded complexes. It induces the canonical identification*

$$(3.11) \quad H(E_s, \bar{\partial}^X + v) \simeq H(F_s, \bar{\partial}^Y).$$

In the whole paper, we assume that $\dim H(X, \xi|_X)$ is locally constant. Then the $H(X_s, \xi|_{X_s})$'s are the fibres of a holomorphic vector bundle $H(X, \xi)$ on S . By (3.8), the dimension of the $H(Y_s, \eta|_{Y_s})$'s is locally constant, and so the $H(Y_s, \eta|_{Y_s})$'s are the fibres of a holomorphic vector bundle $H(Y, \eta)$ on S . By (3.8), (3.9), (3.11), we get the identification of holomorphic \mathbf{Z} -graded vector bundles on S

$$(3.12) \quad \begin{aligned} H(X, \xi|_X) &\simeq H(Y, \eta|_Y), \\ H(E, \bar{\partial}^X + v) &\simeq H(F, \bar{\partial}^Y). \end{aligned}$$

3.2 The analytic torsion forms of the double complex

Let ω^V, ω^W be real smooth $(1, 1)$ forms on V, W which have the properties a) and b) indicated in Theorem 2.2.

To ω^V, ω^W , we associate the objects considered in Chapter 2. To distinguish them from one another, we will often denote them with a superscript V or W . Also g^{TX}, g^{TY} denote the Hermitian metrics on TX, TY induced by ω^V, ω^W .

Let $N_{W/V}$ be the normal bundle to W in V , let $N_{Y/X}$ be the (fibrewise) normal bundle to Y in X . Clearly $N_{W/V} \simeq N_{Y/X}$. We identify $N_{Y/X}$ to the orthogonal bundle to TY in $TX|_W$ with respect to $g^{TX}|_W$. Let $g^{N_{Y/X}}$ be the corresponding metric on $N_{Y/X}$.

As in Section 1.3, one verifies easily that $T_{\mathbf{R}}^{\mathbf{H}}W$ is obtained from $T_{\mathbf{R}}^{\mathbf{H}}V$ by the construction indicated in Definition 1.4.

Let $g^{\xi_0}, \dots, g^{\xi_m}, g^{\eta}$ be Hermitian metrics on $\xi_0, \dots, \xi_m, \eta$. We equip $\xi = \bigoplus_{i=0}^m \xi_i$ with the metric $g^{\xi} = \bigoplus_{i=0}^m g^{\xi_i}$. Let v^* be the adjoint of v with respect to g^{ξ} . Put

$$(3.13) \quad V = v + v^*.$$

We equip the fibres of E (resp. F) with the Hermitian product (2.22) associated to g^{TX}, g^{ξ} (resp. g^{TY}, g^{η}).

For $u > 0$, let B_u^{V, ξ_i} ($0 \leq i \leq m$), B_u^W be the superconnections on E_i, F associated to (ω^V, g^{ξ_i}) and to (ω^W, g^{η}) , whose construction was given in Definition 2.12.

Then we can construct the analytic torsion forms $T(\omega^V, g^{\xi_i})$ and $T(\omega^W, g^{\eta})$ as in Definition 2.20. By Theorem 2.23,

$$(3.14) \quad \frac{\bar{\partial}\partial}{2\pi} T(\omega^W, g^{\eta}) = \text{ch}(H(Y, \eta|_Y), g^{H(Y, \eta|_Y)}) - \int_Y \text{Td}(TY, g^{TY}) \text{ch}(\eta, g^{\eta}).$$

To describe the analytic torsion forms associated to (ω^V, g^{ξ}) , we modify the constructions of Chapter 2. Set

$$(3.15) \quad \begin{aligned} \bar{B}_u^{\prime\prime V} &= \sqrt{u}(\bar{\partial}^X + v) + \nabla^{E''} - \frac{c(T^{(1,0)})}{2\sqrt{2u}}, \\ \bar{B}_u^{\prime V} &= \sqrt{u}(\bar{\partial}^{X*} + v^*) + \nabla^{E'} - \frac{c(T^{(0,1)})}{2\sqrt{2u}}, \\ \bar{B}_u^V &= \bar{B}_u^{\prime\prime V} + \bar{B}_u^{\prime V}. \end{aligned}$$

As in (2.5), we write ω^V in the form

$$(3.16) \quad \omega^V = \omega^{V, TX} + \omega^{V, H}.$$

Definition 3.4. For $u > 0$, set

$$(3.17) \quad \bar{N}_u^V = N_{\mathbf{V}}^X - N_{\mathbf{H}} + \frac{i\omega^{V, H}}{u}.$$

The difference with respect to (2.32) is that the number operator $N_{\mathbf{V}}^X$ has been replaced by the new number operator $N_{\mathbf{V}}^X - N_{\mathbf{H}}$.

Then by [14, Theorem 2.6], \bar{B}_u^V, \bar{N}_u^V verify the obvious analogue of Theorem 2.14. By [14, Theorems 2.2 and 2.9], the forms $\Phi \text{Tr}_s \left[\exp(-\bar{B}_u^{V, 2}) \right]$ and $\Phi \text{Tr}_s \left[\bar{N}_u^V \exp(-\bar{B}_u^{V, 2}) \right]$ lie in P^S . Also by [14, Theorem 2.9], the analogue of Theorem 2.16 holds, i.e. for $u > 0$,

$$(3.18) \quad \frac{\partial}{\partial u} \Phi \text{Tr}_s \left[\exp(-\bar{B}_u^{V, 2}) \right] = -\frac{1}{u} \frac{\bar{\partial}\partial}{2i\pi} \Phi \text{Tr}_s \left[\bar{N}_u^V \exp(-\bar{B}_u^{V, 2}) \right].$$

Put

$$(3.19) \quad \begin{aligned} \text{ch}(\xi, g^\xi) &= \sum_{i=0}^m (-1)^i \text{ch}(\xi_i, g^{\xi_i}), \\ \text{ch}'(\xi, g^\xi) &= \sum_{i=0}^m (-1)^i i \text{ch}(\xi_i, g^{\xi_i}). \end{aligned}$$

Then by [14, Theorems 2.2 and 2.16], the following analogue of Theorem 2.17 holds.

Theorem 3.5 — *As $u \rightarrow 0$,*

$$(3.20) \quad \Phi \text{Tr}_s \left[\exp(-\bar{B}_u^{V,2}) \right] = \int_X \text{Td}(TX, g^{TX}) \text{ch}(\xi, g^\xi) + \mathcal{O}(u).$$

There exist forms $D_{-1}^V, D_0^V, \dots, D_k^V \dots \in P^S$ such that for $k \in \mathbf{N}$, as $u \rightarrow 0$

$$(3.21) \quad \Phi \text{Tr}_s \left[\bar{N}_u^V \exp(-\bar{B}_u^{V,2}) \right] = \sum_{-1}^k D_j^V u^j + \mathcal{O}(u^{k+1}).$$

Moreover

$$(3.22) \quad \begin{aligned} D_{-1}^V &= \int_X \frac{\omega^V}{2\pi} \text{Td}(TX, g^{TX}) \text{ch}(\xi, g^\xi), \\ D_0^V &= \int_X (\dim X \text{Td}(TX) - \text{Td}'(TX)) \text{ch}(\xi) \\ &\quad - \int_X \text{Td}(TX) \text{ch}'(\xi) \quad \text{in } P^S/P^{S,0}. \end{aligned}$$

For $s \in S$, set

$$(3.23) \quad K_s = \left\{ f \in E_s, (\bar{\partial}^X + v)f = 0, (\bar{\partial}^{X*} + v^*)f = 0 \right\}.$$

Then by Hodge theory, $K_s^V \simeq H(X_s, \xi|_{X_s})$. Since the $H(X_s, \xi|_{X_s})$'s have locally constant dimension, the K_s^V are the fibres of a smooth \mathbf{Z} -graded vector bundle K on S , and moreover

$$(3.24) \quad H(X, \xi|_X) \simeq K.$$

As a subbundle of E , K inherits a smooth metric g^K . Let $g^{H(X, \xi|_X)}$ the corresponding metric on $H(X, \xi|_X)$. The arguments of [18, Theorem 3.2] show that the obvious analogue of Theorem 2.19 holds.

Put

$$(3.25) \quad \text{ch} \left(H(X, \xi|_X), g^{H(X, \xi|_X)} \right) = \sum (-1)^i \text{ch}(H^i(X, \xi|_X), g^{H^i(X, \xi|_X)}).$$

Then by proceeding as in [3, Theorem 9.23], the obvious analogue of Theorem 2.20 still holds.

By replacing in (2.47) B_u by \overline{B}_u^V , N_u by \overline{N}_u^V , as in Definition 2.22, we construct a form $T(\omega^V, g^\xi) \in P^S$ such that the analogue of Theorem 2.23 holds, i.e.

$$(3.26) \quad \frac{\overline{\partial}\partial}{2i\pi} T(\omega^V, g^\xi) = \text{ch} \left(H(X, \xi|_X), g^{H(X, \xi|_X)} \right) - \int_X \text{Td}(TX, g^{TX}) \text{ch}(\xi, g^\xi).$$

A simple modification of the arguments of [18] shows that the analogue of Theorem 2.24 still holds.

3.3 Assumptions on the metrics on ξ, η

In the sequel we assume that the metrics $g^{\xi_0}, \dots, g^{\xi_m}$ verify assumption (A) of [5, Section 1b)] with respect to $g^{N_{Y/X}}, g^\eta$. We describe this assumption in more detail.

Recall that $N_{W/V} \cong N_{Y/X}$. On W , we have the exact sequence of holomorphic vector bundles

$$(3.27) \quad 0 \rightarrow TW \rightarrow TV|_V \rightarrow N_{Y/X} \rightarrow 0.$$

For $y \in W$, let $H(\xi, v)_y$ be the homology of the complex $(\xi, v)_y$. Then by [5, Section 1b)], the $H(\xi, v)_y$'s have locally constant dimension. So they are the fibres of a holomorphic vector bundle $H(\xi, v)$ on W .

If $y \in W$, $U \in TV|_W$, let $\partial_U v(y)$ be the derivative of v with respect to any given holomorphic trivialization of ξ near y . Then by [5], $\partial_U v(y)$ acts on $H(\xi, v)_y$, and the action depends only on the image z of U in $N_{W/V} \cong N_{Y/X}$. So we will write $\partial_z v(y)$ instead of $\partial_U v(y)$. By [5], $(\partial_z v(y))^2 = 0$.

Let π be the projection $N_{Y/X} \rightarrow W$. By [5, Theorem 1.2], we have the canonical identification of complexes on $N_{Y/X}$

$$(3.28) \quad (\pi^* H(\xi, v), \partial_z v) \simeq (\pi^*(\Lambda(N_{Y/X}^*) \otimes \eta), \sqrt{-1}i_z).$$

Recall that V was defined in (3.13). By finite dimensional Hodge theory,

$$(3.29) \quad H(\xi, v) \simeq \{s \in \xi|_W, Vs = 0\}.$$

Let $g^{H(\xi, v)}$ be the smooth metric on $H(\xi, v)$ associated to the right-hand side of (3.29), considered as a vector subbundle of $\xi|_W$.

Both sides of (3.28) are now equipped with a Hermitian metric. We say that assumption (A) is verified if (3.28) is an isometry.

By [5, Proposition 1.6], given $g^{N_{Y/X}}, g^\eta$, there exist $g^{\xi_0}, \dots, g^{\xi_m}$ verifying assumption (A) with respect to $g^{N_{Y/X}}, g^\eta$.

3.4 A Bott-Chern current

Let $\nabla^\xi = \bigoplus_{i=0}^m \nabla^{\xi_i}$ be the holomorphic Hermitian connection on $(\xi, g^\xi) = \bigoplus_{i=0}^m (\xi_i, g^{\xi_i})$. For $u \geq 0$, put

$$(3.30) \quad C_u = \nabla^\xi + \sqrt{u}V.$$

Then C_u is a superconnection on ξ in the sense of Quillen [32].

By [32], the forms $\Phi \text{Tr}_s[\exp(-C_u^2)]$ are closed and their cohomology class is equal to $\text{ch}(\xi)$. By [13, Theorem 1.9], the forms $\Phi \text{Tr}_s[\exp(-C_u^2)]$ and $\Phi \text{Tr}_s[N_{\mathbf{H}} \exp(-C_u^2)]$ lie in P^V . If K is a compact subset of V , let $\|\cdot\|_{C^1(V)}$ be a norm on the Banach space of C^1 forms μ on V with support in K .

Nowe we recall result of [5, Theorems 3.2 and 4.3].

Theorem 3.6 — *For any compact set $K \subset V$, there exists $C > 0$ such that if $\mu \in C^1(V)$ has compact support in K , then*

$$(3.31) \quad \left| \int_X \mu \Phi \text{Tr}_s[\exp(-C_u^2)] - \int_Y i^* \mu \text{Td}^{-1}(N_{Y/X}, g^{N_{Y/X}}) \text{ch}(\eta, g^\eta) \right| \leq \frac{C}{\sqrt{u}} \|\mu\|_{C^1(K)},$$

$$\left| \int_X \mu \Phi \text{Tr}_s[N_{\mathbf{H}} \exp(-C_u^2)] + \int_Y i^* \mu (\text{Td}^{-1})'(N_{Y/X}, g^{N_{Y/X}}) \text{ch}(\eta, g^\eta) \right| \leq \frac{C}{\sqrt{u}} \|\mu\|_{C^1(K)}.$$

Definition 3.7. Let P_W^V be the set of real currents on V which are sums of real currents of type (p, p) , whose wave front set is included in $N_{W/V, \mathbf{R}}^* \cong N_{Y/X, \mathbf{R}}^*$. Let $P_W^{V,0}$ be the set of currents $\alpha \in P_W^V$ such that there exist currents β, γ on V , whose wave front set is included in $N_{W/V, \mathbf{R}}^*$, with $\alpha = \bar{\partial}\beta + \partial\gamma$.

Let $\delta_{\{W\}}$ be the current of integration on W . Then $\delta_{\{W\}} \in P_W^V$.

Definition 3.8. For $s \in \mathbf{C}, 0 < \text{Re}(s) < 1/2$, let $R(\xi, g^\xi)(s)$ be the current on V

$$(3.32) \quad R(\xi, g^\xi)(s) = \frac{1}{\Gamma(s)} \int_0^{+\infty} u^{s-1} \{ \Phi \text{Tr}_s[N_{\mathbf{H}} \exp(-C_u^2)] + (\text{Td}^{-1})'(N_{Y/X}, g^{N_{Y/X}}) \text{ch}(\eta, g^\eta) \delta_{\{W\}} \} du.$$

Clearly by Theorem 3.6, the map $s \rightarrow R(\xi, g^\xi)(s)$ extends to a map which is holomorphic at $s = 0$.

Definition 3.9. Let $T(\xi, g^\xi)$ be the current on V ,

$$(3.33) \quad T(\xi, g^\xi) = \frac{\partial}{\partial s} R(\xi, g^\xi)(0).$$

By [16, Section 4a)], we know that $T(\xi, g^\xi)$ is given by the formula

$$(3.34) \quad T(\xi, g^\xi) = \int_0^1 \Phi \operatorname{Tr}_s [N_{\mathbf{H}}(\exp(-C_u^2) - \exp(-C_0^2))] \frac{du}{u} \\ + \int_1^{+\infty} \left\{ \Phi \operatorname{Tr}_s [N_{\mathbf{H}} \exp(-C_u^2)] + (\operatorname{Td}^{-1})'(N_{Y/X}, g^{N_{Y/X}}) \operatorname{ch}(\eta, g^\eta) \delta_{\{W\}} \right\} \frac{du}{u} \\ - \dot{\Gamma}'(1) \left\{ \operatorname{ch}'(\xi, h^\xi) + (\operatorname{Td}^{-1})'(N_{Y/X}, g^{N_{Y/X}}) \operatorname{ch}(\eta, g^\eta) \delta_{\{W\}} \right\}.$$

The following result is proved in [16, Theorem 2.5].

Theorem 3.10 — *The current $T(\xi, h^\xi)$ lies in P_W^V . Also the following equation of currents holds on V*

$$(3.35) \quad \frac{\bar{\partial}\partial}{2i\pi} T(\xi, g^\xi) = \operatorname{Td}^{-1}(N_{Y/X}, g^{N_{Y/X}}) \operatorname{ch}(\eta, g^\eta) \delta_{\{W\}} - \operatorname{ch}(\xi, g^\xi).$$

Remark 3.11. Since $T(\xi, g^\xi) \in P_W^V$, it follows from [30, Theorem 8.2.12] that $\int_X \operatorname{Td}(TX, g^{TX}) T(\xi, g^\xi)$ is a smooth form on S . Of course this form lies in P^S . Also by [17, Theorem 2.5], the dependence of the class of $T(\xi, g^\xi)$ in $P_W^V/P_W^{V,0}$ with respect to g^ξ can be calculated in terms of Bott-Chern classes.

4. An identity on two parameters differential forms

The purpose of this Chapter is to construct a differential form β on $\mathbf{R}_+^* \times \mathbf{R}_+^* \times S$ and a contour Γ in $\mathbf{R}_+^* \times \mathbf{R}_+^*$ depending on three parameters ε, A, T_0 such that $\int_{\Gamma} \beta \in P^{S,0}$. To prove Theorem 0.1, we will later push Γ to the boundary of $\mathbf{R}_+^* \times \mathbf{R}_+^*$.

This Chapter is the obvious extension of [19, Section 3] to the case of a general S . As in [19], our results can also be obtained from general results of [5] on the dependence of the superconnection forms on the given metrics.

This Chapter is organized as follows. In Section 4.1 we construct a basic form α on $\mathbf{R}_+^* \times \mathbf{R}_+^* \times S$. In Section 4.2 we obtain the form β by a change of coordinate of coordinates. In Section 4.3 we describe the contour Γ . Finally in Section 4.4, we establish elementary identities which will be used in Chapter 6.

In this Chapter, the assumptions and notation of Chapter 3 will be in force.

4.1 A basic identity of differential forms

For $u > 0, T > 0$, set

$$(4.1) \quad \begin{aligned} A_{u,T} &= B_{u^2}^V + TV; \\ N_u^V &= N_{\mathbf{V}}^X + \frac{i\omega^{V,H}}{u}. \end{aligned}$$

Then $A_{u,T}$ is a superconnection on E . Put

$$(4.2) \quad d_{u,T} = du \frac{\partial}{\partial u} + dT \frac{\partial}{\partial T}.$$

Then $d_{u,T}$ is the standard de Rham operator acting on smooth forms on $\mathbf{R}_+^* \times \mathbf{R}_+^*$.

We prove an extension of [19, Theorem 3.3].

Theorem 4.1 — *Let $\alpha_{u,T}$ be the form on $\mathbf{R}_+^* \times \mathbf{R}_+^* \times S$,*

$$(4.3) \quad \alpha_{u,T} = \frac{du}{u} \text{Tr}_s [N_{u^2}^V \exp(-A_{u,T}^2)] - \frac{dT}{T} \text{Tr}_s [N_{\mathbf{H}} \exp(-A_{u,T}^2)].$$

Then

$$(4.4) \quad d_{u,T}\alpha_{u,T} = \\ dT du \left[\bar{\partial} \frac{\partial}{\partial b} \left\{ \text{Tr}_s \left[\frac{N_{u^2}^V \exp(-A_{u,T}^2 - bv^*)}{u} \right] \right. \right. \\ \left. \left. + \text{Tr}_s \left[\frac{N_{\mathbf{H}}}{T} \exp(-A_{u,T}^2 - b \frac{\partial}{\partial u} B_{u^2}^{V'}) \right] \right\} \right]_{b=0} \\ + \partial \frac{\partial}{\partial b} \left\{ \left[\frac{N_{u^2}^V \exp(-A_{u,T}^2 - bv)}{u} \right] \right. \\ \left. + \text{Tr}_s \left[\frac{N_{\mathbf{H}}}{T} \exp(-A_{u,T}^2 - b \frac{\partial}{\partial u} B_{u^2}^{V''}) \right] \right\} \Big|_{b=0}.$$

Proof. By the analogue of (2.33), we get

$$(4.5) \quad A_{u,T}^2 = [A'_{u,T}, A''_{u,T}], [A''_{u,T}, A_{u,T}^2] = 0, [A'_{u,T}, A_{u,T}^2] = 0.$$

From (4.5), we obtain

$$(4.6) \quad \frac{\partial}{\partial T} A_{u,T}^2 = \left[A''_{u,T}, \frac{\partial A'_{u,T}}{\partial T} \right] + \left[A'_{u,T}, \frac{\partial A''_{u,T}}{\partial T} \right].$$

Using (4.5), (4.6) and the fact that supertraces vanish on supercommutators [32], (4.6), we get

$$(4.7) \quad \frac{\partial}{\partial T} \text{Tr}_s [N_{u^2}^V \exp(-A_{u,T}^2)] = \\ \frac{\partial}{\partial b} \text{Tr}_s \left[N_{u^2}^V \exp \left(-A_{u,T}^2 - b \left[A''_{u,T}, \frac{\partial A'_{u,T}}{\partial T} \right] - b \left[A'_{u,T}, \frac{\partial A''_{u,T}}{\partial T} \right] \right) \right]_{b=0} \\ = \bar{\partial} \frac{\partial}{\partial b} \text{Tr}_s [N_{u^2}^V \exp(-A_{u,T}^2 - bv^*)]_{b=0} \\ + \partial \frac{\partial}{\partial b} \text{Tr}_s [N_{u^2}^V \exp(-A_{u,T}^2 - bv)]_{b=0} \\ - \frac{\partial}{\partial b} \text{Tr}_s \left[[B_{u^2}^{V''}, N_{u^2}^V] \exp(-A_{u,T}^2 - bv^*) \right]_{b=0} \\ - \frac{\partial}{\partial b} \text{Tr}_s \left[[B_{u^2}^{V'}, N_{u^2}^V] \exp(-A_{u,T}^2 - bV) \right]_{b=0}.$$

Using Theorem 2.14, we have

$$\begin{aligned}
 (4.8) \quad & -\frac{\partial}{\partial b} \operatorname{Tr}_s \left[\left[B_{u^2}^{V''}, N_{u^2}^V \right] \exp(-A_{u,T}^2 - bv^*) \right]_{b=0} \\
 & - \frac{\partial}{\partial b} \operatorname{Tr}_s \left[\left[B_{u^2}^{V'}, N_{u^2}^V \right] \exp(-A_{u,T}^2 - bv) \right]_{b=0} \\
 & = \frac{\partial}{\partial b} \operatorname{Tr}_s \left[u \frac{\partial}{\partial u} A''_{u,T} \exp(-A_{u,T}^2 - bv^*) \right]_{b=0} \\
 & \quad - \frac{\partial}{\partial b} \operatorname{Tr}_s \left[u \frac{\partial}{\partial u} A'_{u,T} \exp(-A_{u,T}^2 - bv) \right]_{b=0} .
 \end{aligned}$$

By (4.7)-(4.8), we find that

$$\begin{aligned}
 (4.9) \quad & \frac{\partial}{\partial T} \operatorname{Tr}_s \left[\frac{N_{u^2}^V}{u} \exp(-A_{u,T}^2) \right] = \\
 & \frac{\partial}{\partial b} \operatorname{Tr}_s \left[\frac{\partial}{\partial u} A''_{u,T} \exp(-A_{u,T}^2 - bv^*) \right]_{b=0} \\
 & - \frac{\partial}{\partial b} \operatorname{Tr}_s \left[\frac{\partial}{\partial u} A'_{u,T} \exp(-A_{u,T}^2 - bv) \right]_{b=0} \\
 & + \bar{\partial} \frac{\partial}{\partial b} \operatorname{Tr}_s \left[\frac{N_{u^2}^V}{u} \exp(-A_{u,T}^2 - bv^*) \right]_{b=0} \\
 & \quad + \partial \frac{\partial}{\partial b} \operatorname{Tr}_s \left[\frac{N_{u^2}^V}{u} \exp(-A_{u,T}^2 - bv) \right]_{b=0} .
 \end{aligned}$$

Similarly

$$\begin{aligned}
 (4.10) \quad & \frac{\partial}{\partial u} \operatorname{Tr}_s \left[N_{\mathbf{H}} \exp(-A_{u,T}^2) \right] = \\
 & \frac{\partial}{\partial b} \operatorname{Tr}_s \left[N_{\mathbf{H}} \exp \left(-A_{u,T}^2 - b \left[A''_{u,T}, \frac{\partial}{\partial u} A'_{u,T} \right] - b \left[A'_{u,T}, \frac{\partial}{\partial u} A''_{u,T} \right] \right) \right]_{b=0} = \\
 & = -\frac{\partial}{\partial b} \operatorname{Tr}_s \left[\left[A''_{u,T}, N_{\mathbf{H}} \right] \exp \left(-A_{u,T}^2 - b \frac{\partial}{\partial u} A'_{u,T} \right) \right]_{b=0} \\
 & - \frac{\partial}{\partial b} \operatorname{Tr}_s \left[\left[A'_{u,T}, N_{\mathbf{H}} \right] \exp \left(-A_{u,T}^2 - b \frac{\partial}{\partial u} A''_{u,T} \right) \right]_{b=0} \\
 & + \bar{\partial} \frac{\partial}{\partial b} \operatorname{Tr}_s \left[N_{\mathbf{H}} \exp \left(-A_{u,T}^2 - b \frac{\partial}{\partial u} A'_{u,T} \right) \right]_{b=0} \\
 & \quad + \partial \frac{\partial}{\partial b} \operatorname{Tr}_s \left[N_{\mathbf{H}} \exp \left(-A_{u,T}^2 - b \frac{\partial}{\partial u} A''_{u,T} \right) \right]_{b=0} .
 \end{aligned}$$

Moreover

$$\begin{aligned}
 (4.11) \quad & -\frac{\partial}{\partial b} \operatorname{Tr}_s \left[[A''_{u,T}, N_{\mathbf{H}}] \exp \left(-A_{u,T}^2 - b \frac{\partial}{\partial u} A'_{u,T} \right) \right]_{b=0} \\
 & - \frac{\partial}{\partial b} \operatorname{Tr}_s \left[[A'_{u,T}, N_{\mathbf{H}}] \exp(-A_{u,T}^2 - b \frac{\partial}{\partial u} A''_{u,T}) \right]_{b=0} \\
 & = -T \frac{\partial}{\partial b} \operatorname{Tr}_s \left[\frac{\partial}{\partial u} A''_{u,T} \exp(-A_{u,T}^2 - bv^*) \right]_{b=0} \\
 & \quad + T \frac{\partial}{\partial b} \operatorname{Tr}_s \left[\frac{\partial}{\partial u} A'_{u,T} \exp(-A_{u,T}^2 - bv) \right]_{b=0}.
 \end{aligned}$$

From (4.9)-(4.11), we get (4.4). \square

Remark 4.2. As in [19, Remark 3.4], Theorem 4.1 can be also considered as a consequence of [5, Theorem 2.2].

4.2 A change of coordinates

For $u > 0$, $T \geq 0$, set

$$(4.12) \quad B_{u,T} = A_{u,uT}.$$

Equivalently

$$(4.13) \quad B_{u,T} = B_{u^2}^V + uTV.$$

Theorem 4.3 — Let $\beta_{u,T}$ be the form on $\mathbf{R}_+^* \times \mathbf{R}_+^* \times S$,

$$(4.14) \quad \beta_{u,T} = \frac{du}{u} \operatorname{Tr}_s [(N_{u^2}^V - N_{\mathbf{H}}) \exp(-B_{u,T}^2)] - \frac{dT}{T} \operatorname{Tr}_s [N_{\mathbf{H}} \exp(-B_{u,T}^2)].$$

The following identity holds

$$\begin{aligned}
 (4.15) \quad d_{u,T} \beta_{u,T} &= udT du \left[\bar{\partial} \frac{\partial}{\partial b} \left\{ \operatorname{Tr}_s \left[\frac{N_{u^2}^V}{u} \exp(-B_{u,T}^2 - bv^*) \right] \right. \right. \\
 &\quad \left. \left. + \operatorname{Tr}_s \left[\frac{N_{\mathbf{H}}}{uT} \exp \left(-B_{u,T}^2 - b \frac{\partial}{\partial u} B_{u^2}^{V'} \right) \right] \right\} \right]_{b=0} \\
 &\quad + \frac{\partial}{\partial b} \left\{ \operatorname{Tr}_s \left[\frac{N_{u^2}^V}{u} \exp(-B_{u,T}^2 - bv) \right] + \right. \\
 &\quad \left. + \operatorname{Tr}_s \left[\frac{N_{\mathbf{H}}}{uT} \exp \left(-B_{u,T}^2 - b \frac{\partial}{\partial u} B_{u^2}^{V''} \right) \right] \right\} \Big|_{b=0}.
 \end{aligned}$$

Proof. By making the change of variables $u \rightarrow u$, $T \rightarrow uT$, our Theorem follows from Theorem 4.1. \square

4.3 A contour integral

We fix constants ε, A, T_0 such that $0 < \varepsilon < 1 < A < +\infty, 1 \leq T_0 < +\infty$. Let $\Gamma = \Gamma_{\varepsilon, A, T_0}$ be the oriented contour in $\mathbf{R}_+^* \times \mathbf{R}_+^*$,

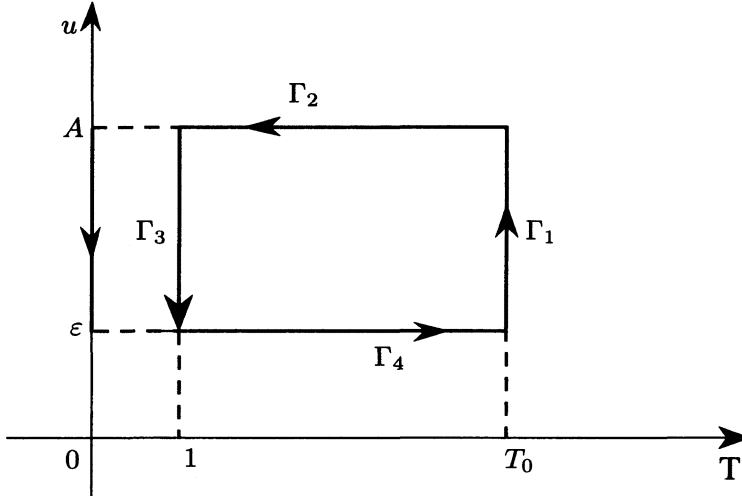

As indicated in the figure above, Γ is made of four oriented segments $\Gamma_1, \dots, \Gamma_4$. Also Γ bounds an oriented rectangular domain Δ .

Definition 4.4. Let γ, δ be the forms on S

$$\begin{aligned}
 \gamma &= \int_{\Delta} \frac{\partial}{\partial b} \left\{ \text{Tr}_s \left[N_{u^2}^V \exp(-B_{u,T}^2 - bv^*) \right] \right. \\
 &\quad \left. + \text{Tr}_s \left[\frac{N_{\mathbf{H}}}{T} \exp \left(-B_{u,T}^2 - b \frac{\partial}{\partial u} B_{u^2}^{V'} \right) \right] \right\}_{b=0} dT du, \\
 \delta &= \int_{\Delta} \frac{\partial}{\partial b} \left\{ \text{Tr}_s \left[N_{u^2}^V \exp(-B_{u,T}^2 - bv) \right] \right. \\
 &\quad \left. + \text{Tr}_s \left[\frac{N_{\mathbf{H}}}{T} \exp \left(-B_{u,T}^2 - b \frac{\partial}{\partial u} B_{u^2}^{V''} \right) \right] \right\}_{b=0} dT du.
 \end{aligned}
 \tag{4.16}$$

Theorem 4.5 — *The following identity holds*

$$\int_{\Gamma} \beta = \bar{\partial} \gamma + \partial \delta.
 \tag{4.17}$$

Proof. Identity (4.17) follows from Theorem 4.3 and from Stokes formula. □

Put

$$I_k^0 = \int_{\Gamma_k} \Phi \beta \quad , \quad 1 \leq k \leq 4.
 \tag{4.18}$$

Then identity (4.17) can be put in the form

$$(4.19) \quad \sum_{k=1}^4 I_k^0 = \Phi(\bar{\partial}\gamma^0 + \partial\delta^0).$$

As in [19], the proof of Theorem 0.1 will consist in making $A \rightarrow +\infty$, $T_0 \rightarrow +\infty$, $\varepsilon \rightarrow 0$ in this order in identity (4.19).

Remark 4.6. In Chapter 14, we will construct a form β' which is the analogue of β when interchanging u and T . This way, we will prove Theorem 0.2.

4.4 Some elementary identities

Now, we will eliminate the differential operators $\frac{\partial}{\partial u} B_{u^2}^{V'}$ in the expression (4.16) for γ, δ . This will prove to be useful in Chapter 6.

Proposition 4.7 — *The following identities hold*

$$(4.20) \quad \begin{aligned} & \frac{\partial}{\partial b} \text{Tr}_s \left[\frac{N_{\mathbf{H}}}{uT} \exp \left(-B_{u,T}^2 - b \frac{\partial}{\partial u} B_{u^2}^{V'} \right) \right]_{b=0} = \\ & \quad \frac{\partial}{\partial b} \text{Tr}_s \left[\frac{N_{\mathbf{H}}}{uT} \exp(-B_{u,T}^2 - b \frac{N_{u^2}^V}{u}) \right]_{b=0} + \frac{\partial}{\partial b} \text{Tr}_s \left[\frac{N_{u^2}^V}{u} \exp(-B_{u,T}^2 - bv^*) \right]_{b=0}, \\ & \frac{\partial}{\partial b} \text{Tr}_s \left[\frac{N_{\mathbf{H}}}{uT} \exp \left(-B_{u,T}^2 - b \frac{\partial}{\partial u} B_{u^2}^{V''} \right) \right]_{b=0} = \\ & \quad - \bar{\partial} \frac{\partial}{\partial b} \text{Tr}_s \left[\frac{N_{\mathbf{H}}}{uT} \exp(-B_{u,T}^2 - b \frac{N_{u^2}^V}{u}) \right]_{b=0} + \frac{\partial}{\partial b} \text{Tr}_s \left[\frac{N_{u^2}^V}{u} \exp(-B_{u,T}^2 - bv) \right]_{b=0}. \end{aligned}$$

Proof. We write $B_{u,T}$ in the form $B_{u,T} = B_{u,T}'' + B_{u,T}'$. By Theorem 2.14,

$$(4.21) \quad \begin{aligned} \frac{\partial}{\partial u} B_{u^2}^{V''} &= -\frac{1}{u} [B_{u,T}', N_{u^2}^V], \quad \frac{\partial}{\partial u} B_{u^2}^{V'} = \frac{1}{u} [B_{u,T}', N_{u^2}^V], \\ v &= \frac{1}{uT} [B_{u,T}'', N_{\mathbf{H}}], \quad v^* = \frac{-1}{uT} [B_{u,T}', N_{\mathbf{H}}]. \end{aligned}$$

From (4.21), we get

$$\begin{aligned}
(4.22) \quad \frac{\partial}{\partial b} \operatorname{Tr}_s \left[\frac{N_{\mathbf{H}}}{uT} \exp \left(-B_{u,T}^2 - b \frac{\partial}{\partial u} B_u^{V'} \right) \right]_{b=0} &= \\
& \frac{\partial}{\partial b} \operatorname{Tr}_s \left[\frac{N_{\mathbf{H}}}{uT} \exp \left(-B_{u,T}^2 - \frac{b}{u} [B'_{u,T}, N_{u^2}^V] \right) \right]_{b=0} \\
&= \frac{\partial}{\partial b} \operatorname{Tr}_s \left[\frac{N_{\mathbf{H}}}{uT} \exp \left(-B_{u,T}^2 - b \frac{N_{u^2}^V}{u} \right) \right]_{b=0} \\
& - \frac{\partial}{\partial b} \operatorname{Tr}_s \left[\left[B'_{u,T}, \frac{N_{\mathbf{H}}}{uT} \right] \exp \left(-B_{u,T}^2 - b \frac{N_{u^2}^V}{u} \right) \right]_{b=0} \\
&= \frac{\partial}{\partial b} \operatorname{Tr}_s \left[\frac{N_{\mathbf{H}}}{uT} \exp \left(-B_{u,T}^2 - b \frac{N_{u^2}^V}{u} \right) \right]_{b=0} \\
& + \frac{\partial}{\partial b} \operatorname{Tr}_s \left[v^* \exp \left(-B_{u,T}^2 - b \frac{N_{u^2}^V}{u} \right) \right]_{b=0} \\
&= \frac{\partial}{\partial b} \operatorname{Tr}_s \left[\frac{N_{\mathbf{H}}}{uT} \exp \left(-B_{u,T}^2 - b \frac{N_{u^2}^V}{u} \right) \right]_{b=0} \\
& \quad + \frac{\partial}{\partial b} \operatorname{Tr}_s \left[\frac{N_{u^2}^V}{u} \exp(-B_{u,T}^2 - bv^*) \right]_{b=0}.
\end{aligned}$$

So we get the first identity in (4.21). The second identity has a similar proof. \square

Definition 4.8. Let η, θ, λ be the forms on S ,

$$\begin{aligned}
(4.23) \quad \eta &= 2 \int_{\Delta} \frac{\partial}{\partial b} \operatorname{Tr}_s \left[\frac{N_{u^2}^V}{u} \exp(-B_{u,T}^2 - buTv^*) \right]_{b=0} \frac{dTdu}{Tu}, \\
\theta &= 2 \int_{\Delta} \frac{\partial}{\partial b} \operatorname{Tr}_s \left[\frac{N_{u^2}^V}{u} \exp(-B_{u,T}^2 - buTV) \right]_{b=0} \frac{dTdu}{Tu}, \\
\lambda &= \int_{\Delta} \frac{\partial}{\partial b} \operatorname{Tr}_s [N_{\mathbf{H}} \exp(-B_{u,T}^2 - bN_{u^2}^V)]_{b=0} \frac{dTdu}{Tu}, \\
\mu &= 2 \int_{\Delta} \frac{\partial}{\partial b} \operatorname{Tr}_s \left[N_{\mathbf{H}} \exp(-B_{u,T}^2 - bu \frac{\partial}{\partial u} B_u^{V'}) \right]_{b=0} \frac{dTdu}{Tu}, \\
\nu &= 2 \int_{\Delta} \frac{\partial}{\partial b} \operatorname{Tr}_s \left[N_{\mathbf{H}} \exp(-B_{u,T}^2 - bu \frac{\partial}{\partial u} B_u^{V''}) \right]_{b=0} \frac{dTdu}{Tu}.
\end{aligned}$$

Proposition 4.9 — *The following identities hold,*

$$\begin{aligned}
(4.24) \quad \gamma &= \eta + \partial\lambda = \mu - \partial\lambda \\
\delta &= \theta - \bar{\partial}\lambda = \nu + \bar{\partial}\lambda.
\end{aligned}$$

Proof. Equation (4.24) follows from Proposition 4.7. \square

Then we can rewrite (4.17) in the form

$$(4.25) \quad \begin{aligned} \int_{\Gamma} \beta &= \bar{\partial}\eta + \partial\theta + 2\bar{\partial}\partial\lambda, \\ \int_{\Gamma} \beta &= \bar{\partial}\mu + \partial\nu - 2\bar{\partial}\partial\lambda, \end{aligned}$$

and (4.19) can be rewritten as

$$(4.26) \quad \begin{aligned} \sum_{k=1}^4 I_k^0 &= \Phi(\bar{\partial}\eta^0 + \partial\theta^0) + \frac{\bar{\partial}\partial\Phi\lambda^0}{i\pi} \\ \sum_{k=1}^4 I_k^0 &= \Phi(\bar{\partial}\mu^0 + \partial\nu^0) - \frac{\bar{\partial}\partial\Phi\lambda^0}{i\pi}. \end{aligned}$$

5. The analytic torsion forms of a short exact sequence

In this Chapter, we recall the main results of [6] on the construction and the evaluation of the analytic torsion forms associated to a short exact sequence of holomorphic Hermitian vector bundles. Also we establish non trivial identities on such generalized supertraces which will be needed in Chapter 6.

This Chapter is organized as follows. In Section 5.1, we give a formula for the curvature \mathcal{R}_u^2 of the superconnection \mathcal{B}_u considered in [6]. In Section 5.2, we introduce two conjugate superconnections $\mathcal{C}_u, \mathcal{D}_u$, whose curvatures reappear in Chapters 12 and 13, and whose geometric interpretation will be given in Chapter 15. In Section 5.3, we introduce the generalized supertrace $\text{Tr}_s [\exp(-\mathcal{R}_u^2)]$ of [6]. In Section 5.4, we recall the transgression formulas of [6] and the results of [6] on the behaviour as $u \rightarrow 0$ or $u \rightarrow +\infty$ of the generalized supertraces. In Section 5.5, we construct the analytic torsion forms of the exact sequence. In Section 5.6, we recall the explicit evaluation in [6] of these analytic torsion forms. In Section 5.7, we construct equivariant analogues of these analytic torsion forms, with respect to the obvious action of the complex structure. In Section 5.8, we establish non trivial identities on generalized supertraces, which will be needed in Chapter 6. Finally in Section 5.9, we give a formula for a conjugate of a curvature operator which will be used in Chapter 13.

5.1 Short exact sequences and superconnections

Let B be a complex manifold. Let

$$(5.1) \quad 0 \rightarrow L \xrightarrow{i} M \xrightarrow{j} N \rightarrow 0$$

be a short exact sequence of holomorphic vector bundles on B .

Let g^M be a Hermitian metric on M . Then g^M induces a Hermitian metric g^L on L . We identify N with the orthogonal bundle to L on M . Therefore N inherits a metric g^N . Let P^L, P^N denote the orthogonal projection operators from M on L, N respectively.

Definition 5.1. For $y \in B$, let I_y be the set of smooth sections of $(\Lambda(\overline{M}^*) \widehat{\otimes} \Lambda(N^*))_y$ along the fibre $M_{\mathbf{R},y}$.

Then I_y is a \mathbf{Z} -graded vector bundle on B . Let $I = I^+ \oplus I^-$ be the corresponding splitting of I into its even and odd part.

Let dv_M be the volume form on the fibres of M . We equip I_y with the Hermitian product

$$(5.2) \quad f, g \in I_y \rightarrow \langle f, g \rangle = \left(\frac{1}{2\pi} \right)^{\dim M} \int_M \langle f, g \rangle dv_M.$$

Let $\bar{\partial}^{M_y}$ be the Dolbeault operator acting on I_y , and let $\bar{\partial}^{M_y*}$ be the formal adjoint of $\bar{\partial}^{M_y}$ with respect to (5.2). Put

$$(5.3) \quad D_y^M = \bar{\partial}^{M_y} + \bar{\partial}^{M_y*}.$$

If $z' \in N$, the operators i_z , and $i_{z'}$, act as odd operators on $\Lambda(\overline{M}^*) \widehat{\otimes} \Lambda(N^*)$. If $Z' = z' + \bar{z}' \in N_{\mathbf{R}}$, put

$$(5.4) \quad V(Z') = \sqrt{-1}(i_{z'} - i_{z'^*}).$$

Equivalently, with the notation of Section 2.2,

$$(5.5) \quad V(Z') = \sqrt{-1} \frac{\widehat{c}(Z')}{\sqrt{2}}.$$

Let $\nabla^L, \nabla^M, \nabla^N$ be the holomorphic Hermitian connections on L, M, N and let R^L, R^M, R^N be their curvatures.

The connection ∇^M defines a horizontal subbundle $T^H M$ of TM . If $U \in T_{\mathbf{R}}B$, let U^H be the horizontal lift of U in $T_{\mathbf{R}}^H M$.

Let $\nabla^{\Lambda(\overline{M}^*) \widehat{\otimes} \Lambda(N^*)}$ be the connection induced by ∇^M and ∇^N on $\Lambda(\overline{M}^*) \widehat{\otimes} \Lambda(N^*)$.

Definition 5.2. If $U \in T_{\mathbf{R}}B$, if s is a smooth section of I , put

$$(5.6) \quad \nabla_{U^H}^I s = \nabla_{U^H}^{\Lambda(\overline{M}^*) \widehat{\otimes} \Lambda(N^*)} s.$$

Then ∇^I is a connection on I , which preserves the Hermitian product (5.2).

Definition 5.3. For $u > 0$, let \mathfrak{B}_u be the superconnection on I

$$(5.7) \quad \mathfrak{B}_u = D^M + \sqrt{u}V(P^N Z) + \nabla^I - \frac{c(R^M Z)}{2\sqrt{2}}.$$

Of course \mathfrak{B}_u splits as

$$(5.8) \quad \mathfrak{B}_u = \mathfrak{B}_u'' + \mathfrak{B}_u'.$$

As in (2.33),

$$(5.9) \quad \begin{aligned} \mathfrak{B}_u''^2 &= 0, \mathfrak{B}_u'^2 = 0, \mathfrak{B}_u^2 = [\mathfrak{B}_u'', \mathfrak{B}_u'], \\ [\mathfrak{B}_u'', \mathfrak{B}_u^2] &= 0, [\mathfrak{B}_u', \mathfrak{B}_u^2] = 0, \\ [\mathfrak{B}_u'', N_{\mathbf{H}}] &= 2u \frac{\partial}{\partial u} \mathfrak{B}_u'', [\mathfrak{B}_u', N_{\mathbf{H}}] = -2u \frac{\partial}{\partial u} \mathfrak{B}_u'. \end{aligned}$$

Let e_1, \dots, e_{2n} be an orthogonal base of $N_{\mathbf{R}}$. As before, we use the notation of Section 2.2.

Definition 5.4. Let $S \in \text{End}^{\text{even}}(\Lambda(\overline{N}^*) \widehat{\otimes} \Lambda(N^*))$ be given by the formula

$$(5.10) \quad S = \frac{\sqrt{-1}}{2} \sum_1^{2n} c(e_i) \widehat{c}(e_i).$$

Note that taking into account the change of notation on the $\widehat{c}(e_i)$'s with respect to [19, Section 5 a)] which was described in Section 2.2, our S is exactly the S of [19, Definition 5.1].

Classically [31, Propositions 6.4 and 6.5], we know that

$$(5.11) \quad \begin{aligned} \nabla^L &= P^L \nabla^M, \\ \nabla^N &= P^N \nabla^M. \end{aligned}$$

Let $R^{\Lambda(N^*)}$ denote the natural action of R^N on $\Lambda(N^*)$. Then $R^{\Lambda(N^*)}$ acts like $1 \widehat{\otimes} R^{\Lambda(N^*)}$ on $\Lambda(\overline{M}^*) \widehat{\otimes} \Lambda(N^*)$.

Let ${}^0\nabla^M = \nabla^L \oplus \nabla^N$ be the connection on M which is the direct sum of the connections ∇^L and ∇^N . Set

$$(5.12) \quad A = \nabla^M - {}^0\nabla^M.$$

Then A is a 1-form on B which takes its values in skew-adjoint elements of $\text{End}(M)$ which interchange L and N .

Let f_1, \dots, f_{2k} be a base of $T_{\mathbf{R}}B$, let f^1, \dots, f^{2k} be the dual base of $T_{\mathbf{R}}^*B$.

Definition 5.5. If $Z \in M_{\mathbf{R}}$, set

$$(5.13) \quad \begin{aligned} c(AP^L Z) &= - \sum_1^{2k} f^\alpha c(A(f_\alpha) P^L Z), \\ \widehat{c}(AP^L Z) &= - \sum_1^{2k} f^\alpha \widehat{c}(A(f_\alpha) P^L Z). \end{aligned}$$

Let $\text{Tr}[R^M]$ denote the $(1, 1)$ form on B which is the trace of R^M . The following result was proved in [6, Theorem 3.10]. Let e_1, \dots, e_{2m} be an orthonormal base of $M_{\mathbf{R}}$.

Theorem 5.6 — For $u > 0$, $\mathfrak{B}_u^2 \in (\Lambda(T_{\mathbf{R}}^*B) \widehat{\otimes} \text{End}(I))^{\text{even}}$ is given by

$$(5.14) \quad \begin{aligned} \mathfrak{B}_u^2 = & -\frac{1}{2} \sum_1^{2m} (\nabla_{e_i} + \langle \frac{1}{2} R^M Z, e_i \rangle)^2 \\ & + \frac{u}{2} |P^N Z|^2 + \sqrt{u} S + \frac{\sqrt{-u}}{\sqrt{2}} \widehat{c}(AP^L Z) + \frac{1}{2} \text{Tr}[R^M] + R^{\Lambda(N^*)}. \end{aligned}$$

Definition 5.7. If $y \in B$, J_y denotes the set of smooth sections of $\Lambda_y(N_{\mathbf{R}}^*) = (\Lambda(\overline{N}^*) \widehat{\otimes} \Lambda(N^*))_y$ over the fibre $M_{\mathbf{R},y}$.

Since $\Lambda(N_{\mathbf{R}}^*)$ is \mathbf{Z} -graded, it is also \mathbf{Z}_2 -graded. If $y \in B$, let $J_{+,y}$ (resp. $J_{-,y}$) be the set of smooth sections of $\Lambda_y^{\text{even}}(N_{\mathbf{R}}^*)$ (resp. $\Lambda_y^{\text{odd}}(N_{\mathbf{R}}^*)$) over the fibre $M_{\mathbf{R},y}$. Clearly $J_y = J_{+,y} \oplus J_{-,y}$.

Here $J = J_+ \oplus J_-$ will be considered as an infinite dimensional \mathbf{Z}_2 -graded vector bundle over B . Our calculations will be done in the \mathbf{Z}_2 -graded algebra $\Lambda(T_{\mathbf{R}}^*B) \widehat{\otimes} \text{End}(J)$. Observe that \mathfrak{B}_u^2 lies in fact in $(\Lambda(T_{\mathbf{R}}^*B) \widehat{\otimes} \text{End}(J))^{\text{even}}$.

5.2 The conjugate superconnections \mathcal{C}_u and \mathcal{D}_u

Now we recall identities of [6, Theorem 4.12] and [19, Theorem 5.6].

Theorem 5.8 — For $u > 0$, set

$$(5.15) \quad \begin{aligned} \mathcal{C}_u &= \exp\left(\frac{c(AP^L Z)}{\sqrt{2}}\right) \mathfrak{B}_u \exp\left(\frac{-c(AP^L Z)}{\sqrt{2}}\right), \\ \mathcal{D}_u &= \exp\left(\frac{c(AP^L Z)}{\sqrt{2}} - \frac{\langle R^M P^N Z, P^L Z \rangle}{2}\right) \\ &\quad \mathfrak{B}_u \exp\left(\frac{-c(AP^L Z)}{\sqrt{2}} + \frac{\langle R^M P^N Z, P^L Z \rangle}{2}\right). \end{aligned}$$

Then the following identities hold

$$(5.16) \quad \begin{aligned} \mathcal{C}_u^2 &= -\frac{1}{2} \sum_1^{2m} \left(\nabla_{e_i} + \frac{1}{2} \langle (R^M - P^L A^2 P^L) Z, e_i \rangle - \frac{c(AP^L e_i)}{\sqrt{2}} \right)^2 \\ &\quad + \frac{u}{2} |P^N Z|^2 + \sqrt{u} S + \frac{1}{2} \text{Tr}[R^M] + R^{\Lambda(N^*)}, \\ \mathcal{D}_u^2 &= -\frac{1}{2} \sum_1^{2m} \left(\nabla_{e_i} + \frac{1}{2} \langle (R^M - P^L A^2 P^L) Z, e_i \rangle \right. \\ &\quad \left. + \frac{1}{2} \langle R^M P^N Z, P^L e_i \rangle - \frac{1}{2} \langle R^M P^L Z, P^N e_i \rangle - \frac{c(AP^L e_i)}{\sqrt{2}} \right)^2 \\ &\quad + \frac{u}{2} |P^N Z|^2 + \sqrt{u} S + \frac{1}{2} \text{Tr}[R^M] + R^{\Lambda(N^*)}. \end{aligned}$$

Remark 5.9. In Chapter 15, we will give a geometric interpretation of the identities (5.15), (5.16).

5.3 Generalized supertraces

Let dv_M, dv_N be the volume forms on the fibres of $M_{\mathbf{R}}, N_{\mathbf{R}}$ respectively. All the smooth kernels along the fibres of $M_{\mathbf{R}}$ will be calculated with respect to the form $dv_M(Z)/(2\pi)^{\dim M}$.

We denote by $N_{\mathbf{H}}$ the operator in $\text{End}(\Lambda(N^*))$ which defines the \mathbf{Z} -grading of $\Lambda(N^*)$, i.e. $N_{\mathbf{H}}$ acts by multiplication by p on $\Lambda^p(N^*)$. Then $N_{\mathbf{H}}$ acts like $1 \hat{\otimes} N_{\mathbf{H}}$ on $\Lambda(\overline{N}^*) \hat{\otimes} \Lambda(N^*)$.

For $u > 0$, let $Q_u^y(Z, Z')(Z, Z' \in M_{\mathbf{R},y})$ denote the smooth kernel associated with the operator $\exp(-\mathfrak{B}_u^{2,y})$. The existence and uniqueness of $Q_u^y(Z, Z')$ are standard.

Observe that $Q_u^y(Z, Z') \in (\Lambda(T_{\mathbf{R}}^*B) \hat{\otimes} \text{End}(\Lambda(\overline{N}^*) \hat{\otimes} \Lambda(N^*)))^{\text{even}}$. We use the conventions of Quillen [32] described in Section 4.2. In particular $\text{Tr}_s[Q_u^y(Z, Z')]$ lies in $\Lambda^{\text{even}}(T_{\mathbf{R}}^*B)$.

By [6, Theorem 4], we know that for $u > 0$, there exist $c > 0, C > 0$ such that if $y \in B, Z \in N_{\mathbf{R},y}$, then

$$(5.17) \quad |Q_u^y(Z, Z)| \leq c \exp(-C|Z|^2).$$

Note that in (5.17), it is crucial that Z is restricted to vary in $N_{\mathbf{R},y}$.

In view of (5.17) and following [6, Definition 4.4], we now set the following definition.

Definition 5.10. For $u > 0$, set

$$(5.18) \quad \begin{aligned} \text{Tr}_s[\exp(-\mathfrak{B}_u^2)]_y &= \int_{N_{\mathbf{R},y}} \text{Tr}_s[Q_u^y(Z, Z)] \frac{dv_N(Z)}{(2\pi)^{\dim N}}, \\ \text{Tr}_s[N_{\mathbf{H}} \exp(-\mathfrak{B}_u^2)]_y &= \int_{N_{\mathbf{R},y}} \text{Tr}_s[N_{\mathbf{H}} Q_u^y(Z, Z)] \frac{dv_N(Z)}{(2\pi)^{\dim N}}. \end{aligned}$$

Note that $\text{Tr}_s[\exp(-\mathfrak{B}_u^2)]_y$ and $\text{Tr}_s[N_{\mathbf{H}} \exp(-\mathfrak{B}_u^2)]_y$ are only generalized supertraces. In fact the operator $\exp(-\mathfrak{B}_u^2)$ is in general not trace class.

Using (5.15), and the fact that supertraces vanish on supercommutators [32], it is clear that $\exp(-\mathcal{C}_u^2), \exp(-\mathcal{D}_u^2), N_{\mathbf{H}} \exp(-\mathcal{C}_u^2), N_{\mathbf{H}} \exp(-\mathcal{D}_u^2)$ also have generalized supertraces $\text{Tr}_s[\exp(-\mathcal{C}_u^2)], \text{Tr}_s[\exp(-\mathcal{D}_u^2)], \text{Tr}_s[N_{\mathbf{H}} \exp(-\mathcal{C}_u^2)], \text{Tr}_s[N_{\mathbf{H}} \exp(-\mathcal{D}_u^2)]$ and that

$$(5.19) \quad \begin{aligned} \text{Tr}_s[\exp(-\mathfrak{B}_u^2)] &= \text{Tr}_s[\exp(-\mathcal{C}_u^2)] = \text{Tr}_s[\exp(-\mathcal{D}_u^2)], \\ \text{Tr}_s[N_{\mathbf{H}} \exp(-\mathfrak{B}_u^2)] &= \text{Tr}_s[N_{\mathbf{H}} \exp(-\mathcal{C}_u^2)] = \text{Tr}_s[N_{\mathbf{H}} \exp(-\mathcal{D}_u^2)]. \end{aligned}$$

5.4 Transgression formulas and convergence of generalized supertraces

We now recall several results of [6, Theorems 4.6, 4.8 and 7.7].

Theorem 5.11 — *For any $u > 0$, the forms $\Phi \text{Tr}_s[\exp(-\mathfrak{R}_u^2)]$ are closed, lie in P^B , and their cohomology class does not depend on $u > 0$. The forms $\Phi \text{Tr}_s[N_{\mathbf{H}} \exp(-\mathfrak{R}_u^2)]$ lie in P^B . Moreover, for $u > 0$,*

$$(5.20) \quad \frac{\partial}{\partial u} \Phi \text{Tr}_s [\exp(-\mathfrak{R}_u^2)] = \frac{\bar{\partial} \partial}{2i\pi} \Phi \text{Tr}_s \left[\frac{N_{\mathbf{H}}}{u} \exp(-\mathfrak{R}_u^2) \right].$$

As $u \rightarrow 0$,

$$(5.21) \quad \begin{aligned} \Phi \text{Tr}_s[\exp(-\mathfrak{R}_u^2)] &= \text{Td}^{-1}(N, g^N) \text{Td}(M, g^M) + O(u), \\ \Phi \text{Tr}_s[N_{\mathbf{H}} \exp(-\mathfrak{R}_u^2)] &= -(\text{Td}^{-1})'(N, g^N) \text{Td}(M, g^M) + O(u). \end{aligned}$$

As $u \rightarrow +\infty$,

$$(5.22) \quad \begin{aligned} \Phi \text{Tr}_s[\exp(-\mathfrak{R}_u^2)] &= \text{Td}(L, g^L) + O\left(\frac{1}{\sqrt{u}}\right), \\ \Phi \text{Tr}_s[N_{\mathbf{H}} \exp(-\mathfrak{R}_u^2)] &= \frac{\dim N}{2} \text{Td}(L, g^L) + O\left(\frac{1}{\sqrt{u}}\right). \end{aligned}$$

Remark 5.12. In [19, Section 14], another proof of (5.22) was sketched, using the expression (5.16) for \mathfrak{D}_u^2 . In Chapter 15, we will sketch a “simpler” proof of (5.22), based on the explicit form of \mathfrak{D}_u , and on some ideas of the present paper, when applied to a toy case.

5.5 Generalized analytic torsion forms

We now reproduce the construction in [6, Section 8] of generalized analytic torsion forms.

Definition 5.13. For $s \in \mathbf{C}$, $0 < \text{Re}(s) < 1/2$, let $\mathbf{B}(s)$ be the form on B ,

$$(5.23) \quad \mathbf{B}(s) = \frac{1}{\Gamma(s)} \int_0^{+\infty} u^{s-1} \left\{ \Phi \text{Tr}_s[N_{\mathbf{H}} \exp(-\mathfrak{R}_u^2)] - \frac{\dim N}{2} \text{Td}(L, g^L) \right\} du.$$

One verifies in [6, Section 8a)] that $\mathbf{B}(s)$ extends to a function of s which is holomorphic near $s = 0$.

Definition 5.14. Let $\mathbf{B}(L, M, g^M)$ be the form on B

$$(5.24) \quad \mathbf{B}(L, M, g^M) = \frac{\partial \mathbf{B}}{\partial s}(0).$$

By [6, eq. (4.37), (8.2)], the following identity holds

$$\begin{aligned}
 \mathbf{B}(L, M, g^M) &= \int_0^1 \left\{ \Phi \operatorname{Tr}_s[N_{\mathbf{H}} \exp(-\mathfrak{R}_u^2)] + \operatorname{Td}(M, g^M)(\operatorname{Td}^{-1})'(N, g^N) \right\} \frac{du}{u} \\
 (5.25) \quad &+ \int_1^{+\infty} \left\{ \Phi \operatorname{Tr}_s[N_{\mathbf{H}} \exp(-\mathfrak{R}_u^2)] - \frac{\dim N}{2} \operatorname{Td}(L, g^L) \right\} \frac{du}{u} \\
 &+ \Gamma'(1) \left\{ \operatorname{Td}(M, g^M)(\operatorname{Td}^{-1})'(N, g^N) + \frac{\dim N}{2} \operatorname{Td}(L, g^L) \right\}.
 \end{aligned}$$

The following result is proved [6, Theorem 8.3].

Theorem 5.15 — *The form $\mathbf{B}(L, M, g^M)$ lies in P^B . Also*

$$(5.26) \quad \frac{\bar{\partial}\partial}{2i\pi} \mathbf{B}(L, M, g^M) = \operatorname{Td}(L, g^L) - \frac{\operatorname{Td}(M, g^M)}{\operatorname{Td}(N, g^N)}.$$

5.6 Evaluation of the generalized analytic torsion forms

We now describe the main results of [6] concerning the evaluation of the form $\mathbf{B}(L, M, g^M)$. Recall that the Hirzebruch polynomial $\widehat{A}(x)$ is given by

$$(5.27) \quad \widehat{A}(x) = \frac{x/2}{\sinh(x/2)}.$$

We identify \widehat{A} to the corresponding multiplicative genus.

Let $\widetilde{\operatorname{Td}}(L, M, g^M)$ be the Bott-Chern class in $P^B/P^{B,0}$ associated to the exact sequence of holomorphic Hermitian vector bundle (5.1), which is constructed in [13, Theorem 1.29] and is such that

$$(5.28) \quad \frac{\bar{\partial}\partial}{2i\pi} \widetilde{\operatorname{Td}}(L, M, g^M) = \operatorname{Td}(M, g^M) - \operatorname{Td}(L, g^L) \operatorname{Td}(N, g^N).$$

The class $\widetilde{\operatorname{Td}}(L, M, g^M)$ is normalized by the fact that if the exact sequence (5.1) splits holomorphically (and here also metrically), then $\widetilde{\operatorname{Td}}(L, M, g^M) = 0$ in $P^B/P^{B,0}$.

Let $\zeta(s)$ be the Riemann zeta function.

Definition 5.16. Put

$$\begin{aligned}
 R(x) &= \sum_{\substack{n \geq 1 \\ n \text{ odd}}} \left(\sum_1^n \frac{1}{j} + \frac{2\zeta'(-n)}{\zeta(-n)} \right) \zeta(-n) \frac{x^n}{n!}, \\
 (5.29) \quad D(x) &= \sum_{\substack{n \geq 1 \\ n \text{ odd}}} \left(\Gamma'(1) + \sum_1^n \frac{1}{j} + \frac{2\zeta'(-n)}{\zeta(-n)} \right) \zeta(-n) \frac{x^n}{n!}.
 \end{aligned}$$

By [6, Remark 8.8],

$$(5.30) \quad D(x) = R(x) + \Gamma'(1) \frac{\widehat{A}'}{\widehat{A}}(x).$$

The power series $R(x)$ was introduced by Gillet-Soulé [26] and the power series $D(x)$ in [6].

We identify $D(x)$, $R(x)$ with the corresponding additive genera. In particular $\mathrm{Td}(L)D(N)$ is a well-defined element of $P^B/P^{B,0}$.

The following result has been proved in [6, Theorem 8.5] and in [6, Appendix].

Theorem 5.17 — *The following identity holds*

$$(5.31) \quad \mathbf{B}(L, M, g^M) = -\mathrm{Td}^{-1}(N, g^N) \widetilde{\mathrm{Td}}(L, M, g^M) + \mathrm{Td}(L)D(N) \text{ in } P^B/P^{B,0}.$$

5.7 Equivariant generalized analytic torsion forms

In this Section, we discuss briefly the construction of equivariant analytic torsion forms associated to short exact sequences. These torsion forms are distinct from the ones of [8], which are constructed in the context of the Lefschetz fixed point formula.

Let J^M be the complex structure of $M_{\mathbf{R}}$. Observe that $J^M Z$ is a holomorphic Killing vector field acting along the fibres of M , which preserves L and N . In particular the Lie derivative operator $L_{J^M Z}$ acts naturally on the vector bundle $\Lambda(\overline{M}^*) \widehat{\otimes} \Lambda(N^*)$. Then for $h \in \mathbf{C}$,

$$(5.32) \quad \begin{aligned} \left(\mathfrak{B}_u'' + \frac{hc(z)}{2\sqrt{2}} \right)^2 = 0, \quad \left(\mathfrak{B}_u' - \frac{hc(\bar{z})}{2\sqrt{2}} \right)^2 = 0 \\ \left[L_{iJ^M Z}, \mathfrak{B}_u'' + \frac{hc(z)}{2\sqrt{2}} \right] = 0, \quad \left[L_{iJ^M Z}, \mathfrak{B}_u' - \frac{hc(\bar{z})}{2\sqrt{2}} \right] = 0. \end{aligned}$$

Theorem 5.18 — *For $u > 0$, $h \in \mathbf{R}$, the following identity of operators in $(\Lambda(T_{\mathbf{R}}^* B) \widehat{\otimes} \mathrm{End}(I))^{\mathrm{even}}$ holds*

$$(5.33) \quad \begin{aligned} -L_{ihJ^M Z} + \left(\mathfrak{B}_u - \frac{c(ihJ^M Z)}{2\sqrt{2}} \right)^2 = -\frac{1}{2} \sum_1^{2m} (\nabla_{e_i} + \frac{1}{2} \langle (R^M + ihJ^M Z), e_i \rangle)^2 \\ + \frac{u}{2} |P^N Z|^2 + \sqrt{u} S + \frac{\sqrt{-u}}{2} \widehat{c}(AP^L Z) + \frac{1}{2} \mathrm{Tr} [R^M - h] + R^{\Lambda(N^*)} + hN_{\mathbf{H}}. \end{aligned}$$

Proof. Formula (5.33) can be proved directly. Another proof is to use Theorem 5.6 (for the case where $h = 0$) and to check that the coefficients of h and h^2 coincide in both sides of (5.33). A still more sophisticated proof is to observe that (5.33) is in fact a consequence of Theorem 5.6, where $-hiJ^M$ is itself part of an enlarged “curvature” $R^M + hiJ^M$. This point is discussed in more detail in [4, Remark 3.2] (in relation with [9]) in the context of the local families index theorem. \square

Remark 5.19. Of course we have the identity

$$(5.34) \quad \frac{1}{2} \operatorname{Tr} [R^M - h] = \frac{1}{2} \operatorname{Tr}[R^M] - \frac{h \dim M}{2}.$$

At least formally, the right-hand side of (5.33) is just the operator \mathfrak{B}_u^2 where R^M , R^N are replaced by $R^M - h$, $R^N - h$.

By proceeding as in [6], for $u > 0$, $h \in \mathbf{R}$, one can still define the generalized supertraces $\operatorname{Tr}_s \left[\exp \left(- \left(-L_{ihJM}Z + \left(\mathfrak{B}_u - \frac{c}{2\sqrt{2}}(ihJ^M Z) \right)^2 \right) \right) \right]$ and $\operatorname{Tr}_s \left[N_{\mathbf{H}} \exp \left(- \left(-L_{ihJM}Z + \left(\mathfrak{B}_u - \frac{c}{2\sqrt{2}}(ihJ^M Z) \right)^2 \right) \right) \right]$. Note here that it is essential that $h \in \mathbf{R}$ for the generalized supertrace to be well-defined. Using (5.32) and proceeding as in [6, Theorem 4.6], the obvious extension of Theorem 5.11 is still valid. In particular

$$(5.35) \quad \frac{\partial}{\partial u} \operatorname{Tr}_s \left[\exp \left(- \left(-L_{ihJM}Z + \left(\mathfrak{B}_u - \frac{c}{2\sqrt{2}}(ihJ^M Z) \right)^2 \right) \right) \right] \\ = \overline{\partial \partial} \operatorname{Tr}_s \left[\frac{N_{\mathbf{H}}}{u} \exp \left(- \left(-L_{ihJM}Z + \left(\mathfrak{B}_u - \frac{c}{2\sqrt{2}}(ihJ^M Z) \right)^2 \right) \right) \right].$$

If A is a (q, q) matrix, set

$$(5.36) \quad \begin{aligned} \operatorname{Td}_h(A) &= \operatorname{Td}(A + h), \\ \operatorname{Td}'_h(A) &= \frac{\partial}{\partial h} \operatorname{Td}(A + h) \\ (\operatorname{Td}_h^{-1})'(A) &= \frac{\partial}{\partial h} (\operatorname{Td}_h^{-1})(A). \end{aligned}$$

By noting that the right-hand side (5.33) is the obvious modifications of \mathfrak{B}_u^2 which was just described, we find that the extensions of (5.21), (5.22) hold, where Td , Td^{-1} , $(\operatorname{Td}^{-1})'$ are replaced by their obvious analogues Td_h , Td_h^{-1} , $(\operatorname{Td}_h^{-1})'$.

Definition 5.20. For $h \in \mathbf{R}$, $s \in \mathbf{C}$, $0 < \operatorname{Re}(s) < 1/2$, let $\mathbf{B}_h(s)$ be the form on B

$$(5.37) \quad \mathbf{B}_h(s) = \frac{1}{\Gamma(s)} \int_0^{+\infty} u^{s-1} \left\{ \Phi \operatorname{Tr}_s \left[N_{\mathbf{H}} \exp \left(- \left(-L_{ihJM}Z + \left(\mathfrak{B}_u - \frac{c}{2\sqrt{2}}(ihJ^M Z) \right)^2 \right) \right) \right] - \dim \frac{N}{2} \operatorname{Td}_h(L, g^L) \right\} du.$$

Again $\mathbf{B}_h(s)$ extends to a holomorphic function near $s = 0$.

Definition 5.21. Put

$$(5.38) \quad \mathbf{B}_h(L, M, g^M) = \frac{\partial \mathbf{B}_h}{\partial s}(0).$$

The obvious extension of Theorem 5.15 is as follows.

Theorem 5.22 — *The form $\mathbf{B}_h(L, M, g^M)$ lies in $P^B \otimes_{\mathbf{R}} \mathbf{C}$. Also*

$$(5.39) \quad \frac{\bar{\partial}\partial}{2i\pi} \mathbf{B}_h(L, M, g^M) = \text{Td}_h(L, g^L) - \frac{\text{Td}_h(M, g^M)}{\text{Td}_h(N, g^N)}.$$

Again, we can define the Bott-Chern class $\widetilde{\text{Td}}_h(L, M, g^M)$ as in (5.28).

By [6, Appendix], the series $R(x)$ and $D(x)$ converge for $|x| < 2\pi$. Put

$$(5.40) \quad R_h(x) = R(x+h) \quad , \quad D_h(x) = D(x+h).$$

Theorem 5.23 — *For $h \in \mathbf{R}$, $|h| < 2\pi$, the following identity holds*

$$(5.41) \quad \mathbf{B}_h(L, M, g^M) = -\text{Td}_h^{-1}(N, g^N) \widetilde{\text{Td}}_h(L, M, g^M) \\ + \text{Td}_h(L) D_h(N) \quad \text{in } P^B/P^{B,0} \otimes_{\mathbf{R}} \mathbf{C}.$$

Proof. The proof of (5.42) is formally the same as the proof of [6, Theorem 8.5]. \square

Remark 5.24. From (5.39), we deduce that

$$(5.42) \quad \frac{\bar{\partial}\partial}{2i\pi} \frac{\partial \mathbf{B}_h}{\partial h}(0)_{h=0} = \text{Td}'(L, g^L) - \text{Td}'(M, g^M) \text{Td}^{-1}(N, g^N) \\ - \text{Td}(M, g^M) (\text{Td}^{-1})'(N, g^N).$$

By differentiating (5.41) at $h = 0$, we get a non trivial identity for $\frac{\partial \mathbf{B}_h}{\partial h}(0)_{h=0}$. Of course (5.40)-(5.42) make sense for arbitrary $h \in \mathbf{R}$. This is because by [6, Appendix], D_h extends to a meromorphic function on \mathbf{C} , whose poles lie on the imaginary axis.

5.8 Some identities on generalized supertraces

Let da be the canonical generator of \mathbf{C}^* . Then $da, d\bar{a}$ generate $\mathbf{R}^{2*} \otimes_{\mathbf{R}} \mathbf{C}$. If $\alpha \in \Lambda(T_{\mathbf{R}}^* B) \widehat{\otimes} \Lambda(\mathbf{R}^{2*})$, then α can be written in the form

$$\alpha = \lambda + da\mu + d\bar{a}\nu + dad\bar{a}o, \quad \lambda, \mu, \nu, o \in \Lambda(T_{\mathbf{R}}^* B).$$

Put

$$(5.43) \quad \alpha^{da} = \mu \quad , \quad \alpha^{d\bar{a}} = \nu \quad , \quad \alpha^{dad\bar{a}} = o.$$

First, we extend identities of [13, Theorems 1.10, 1.12], [14, Theorem 2.13] to generalized supertraces.

Proposition 5.25 — *The following identity holds,*

$$(5.44) \quad \frac{\partial}{\partial u} \text{Tr}_s [\exp(-\mathcal{B}_u^2 + cN_{\mathbf{H}})] = \\ - \frac{c}{u} \text{Tr}_s \left[\exp(-\mathcal{B}_u^2 - da2u \frac{\partial \mathcal{B}_u''}{\partial u} - d\bar{a}2u \frac{\partial \mathcal{B}_u'}{\partial u} + cN_{\mathbf{H}}) \right]^{dad\bar{a}} \\ + \frac{\bar{\partial}\partial}{uc} \text{Tr}_s [\exp(-\mathcal{B}_u^2 + cN_{\mathbf{H}})].$$

Proof. Recall that we consider only generalized supertraces. As in [6, Proof of Theorem 4.6], one has to be quite careful in the formal manipulation of such supertraces, especially when using the fact that the supercommutator of supertraces vanish. For more details we refer to [6]. We have

$$\begin{aligned}
 (5.45) \quad \frac{\partial}{\partial u} \operatorname{Tr}_s \left[\exp(-\mathcal{R}_u^2 + cN_{\mathbf{H}}) \right] &= \\
 & \frac{\partial}{\partial b} \operatorname{Tr}_s \left[\exp(-\mathcal{R}_u^2 - b \left[\mathcal{R}_u'', \frac{\partial \mathcal{R}'_u}{\partial u} \right] + cN_{\mathbf{H}}) \right]_{b=0} \\
 & + \frac{\partial}{\partial b} \operatorname{Tr}_s \left[\exp(-\mathcal{R}_u^2 - b \left[\mathcal{R}'_u, \frac{\partial \mathcal{R}''_u}{\partial u} \right] + cN_{\mathbf{H}}) \right]_{b=0} \\
 & = \bar{\partial} \operatorname{Tr}_s \left[\exp(-\mathcal{R}_u^2 - d\bar{a} \frac{\partial \mathcal{R}'_u}{\partial u} + cN_{\mathbf{H}}) \right]^{d\bar{a}} \\
 & + \partial \operatorname{Tr}_s \left[\exp(-\mathcal{R}_u^2 - da \frac{\partial \mathcal{R}''_u}{\partial u} + cN_{\mathbf{H}}) \right]^{da} \\
 & - c \operatorname{Tr}_s \left[\exp(-\mathcal{R}_u^2 - d\bar{a} \frac{\partial \mathcal{R}'_u}{\partial u} - da [\mathcal{R}_u'', N_{\mathbf{H}}] + cN_{\mathbf{H}}) \right]^{dad\bar{a}} \\
 & - c \operatorname{Tr}_s \left[\exp(-\mathcal{R}_u^2 - da \frac{\partial \mathcal{R}''_u}{\partial u} + d\bar{a} [\mathcal{R}'_u, N_{\mathbf{H}}] + cN_{\mathbf{H}}) \right]^{dad\bar{a}}.
 \end{aligned}$$

From (5.9), we get

$$\begin{aligned}
 (5.46) \quad \operatorname{Tr}_s \left[\exp(-\mathcal{R}_u^2 - d\bar{a} \frac{\partial \mathcal{R}'_u}{\partial u} + cN_{\mathbf{H}}) \right]^{d\bar{a}} &= \frac{1}{2uc} \partial \operatorname{Tr}_s \left[\exp(-\mathcal{R}_u^2 + cN_{\mathbf{H}}) \right], \\
 \operatorname{Tr}_s \left[\exp(-\mathcal{R}_u^2 - d\bar{a} \frac{\partial \mathcal{R}''_u}{\partial u} + cN_{\mathbf{H}}) \right]^{da} &= \frac{-1}{2uc} \bar{\partial} \operatorname{Tr}_s \left[\exp(-\mathcal{R}_u^2 + cN_{\mathbf{H}}) \right].
 \end{aligned}$$

Using (5.45), (5.46), we get (5.44). The proof of our Proposition is completed. \square

Proposition 5.26 — *The following identities hold,*

$$\begin{aligned}
 & \frac{\partial}{\partial u} \operatorname{Tr}_s \left[N_{\mathbf{H}} \exp(-\mathcal{R}_u^2) \right] = -\frac{1}{u} \operatorname{Tr}_s \left[\exp(-\mathcal{R}_u^2 - da2u \frac{\partial \mathcal{R}''_u}{\partial u} - d\bar{a}2u \frac{\partial \mathcal{R}'_u}{\partial u}) \right] \\
 & \quad + \frac{\bar{\partial} \partial}{u} \frac{1}{2} \frac{\partial^2}{\partial c^2} \operatorname{Tr}_s \left[\exp(-\mathcal{R}_u^2 + cN_{\mathbf{H}}) \right]_{c=0}, \\
 (5.47) \quad \frac{\partial}{\partial u} \frac{1}{2} \frac{\partial^2}{\partial c^2} \operatorname{Tr}_s \left[\exp(-\mathcal{R}_u^2 + cN_{\mathbf{H}}) \right]_{c=0} &= \\
 & - \operatorname{Tr}_s \left[\frac{N_{\mathbf{H}}}{u} \exp(-\mathcal{R}_u^2 - da2u \frac{\partial \mathcal{R}''_u}{\partial u} - d\bar{a}2u \frac{\partial \mathcal{R}'_u}{\partial u}) \right]^{dad\bar{a}} \\
 & + \frac{\bar{\partial} \partial}{u} \frac{1}{6} \frac{\partial^3}{\partial c^3} \operatorname{Tr}_s \left[\exp(-\mathcal{R}_u^2 + cN_{\mathbf{H}}) \right]_{c=0}.
 \end{aligned}$$

Proof. We obtain (5.47) by differentiating (5.44) at $c = 0$. Note in particular that by [6, Theorem 4.6], we have the identity of generalized supertraces

$$(5.48) \quad \frac{\partial}{\partial b} \operatorname{Tr}_s [\exp(-\mathfrak{R}_u^2 + bN_{\mathbf{H}})] = \operatorname{Tr}_s [N_{\mathbf{H}} \exp(-\mathfrak{R}_u^2)] .$$

The proof of our Proposition is completed. \square

As before, we only consider generalized supertraces in the sense of Section 5.3.

Definition 5.27. For $u > 0$, put

$$(5.49) \quad \begin{aligned} \Theta_u &= \frac{\partial}{\partial b} \operatorname{Tr}_s \left[\exp \left(- \left(-\frac{1}{2} \sum_1^{2m} (\nabla_{e_i} + \frac{1}{2} \langle (R^M - iJ^M \operatorname{d}a \operatorname{d}\bar{a}) Z, e_i \rangle)^2 + u \frac{|P^N Z|^2}{2} \right. \right. \right. \\ &\quad \left. \left. + \sqrt{u} S + \sqrt{-u} \frac{\widehat{c}}{\sqrt{2}} (A P^L Z) + \operatorname{d}a \sqrt{-u} \frac{\widehat{c}}{\sqrt{2}} (P^N z) + \operatorname{d}\bar{a} \sqrt{-u} \frac{\widehat{c}}{\sqrt{2}} (P^N \bar{z}) \right. \right. \\ &\quad \left. \left. - \operatorname{d}a \operatorname{d}\bar{a} \frac{\dim M}{2} + \frac{1}{2} \operatorname{Tr}[R^M] + R^{\wedge(N^*)} + bN_{\mathbf{H}} \right) \right]_{b=0}^{\operatorname{d}a \operatorname{d}\bar{a}}, \\ \Lambda_u &= \operatorname{Tr}_s \left[\exp(-\mathfrak{R}_u^2 - \operatorname{d}a \sqrt{-u} \frac{\widehat{c}(z)}{\sqrt{2}} - \operatorname{d}\bar{a} \sqrt{-u} \frac{\widehat{c}(\bar{z})}{\sqrt{2}}) \right]_{b=0}^{\operatorname{d}a \operatorname{d}\bar{a}}, \\ \Pi'_u &= \operatorname{Tr}_s \left[N_{\mathbf{H}} \exp \left(- \left(\mathfrak{R}_u^2 + \operatorname{d}\bar{a} \sqrt{-u} \frac{\widehat{c}(\bar{z})}{\sqrt{2}} \right) \right) \right]_{b=0}^{\operatorname{d}\bar{a}}, \\ \Pi''_u &= \operatorname{Tr}_s \left[N_{\mathbf{H}} \exp \left(- \left(\mathfrak{R}_u^2 + \operatorname{d}a \sqrt{-u} \frac{\widehat{c}(z)}{\sqrt{2}} \right) \right) \right]_{b=0}^{\operatorname{d}a}. \end{aligned}$$

By proceeding as in [6, proof of Theorem 4.6], one verifies easily that Θ_u and Λ_u are sums of (p, p) forms, Π'_u a sum of $(p+1, p)$ forms, and Π''_u a sum of $(p, p+1)$ forms.

Proposition 5.28 — For $u > 0$,

$$(5.50) \quad \begin{aligned} \Pi'_u &= \partial \frac{1}{2} \frac{\partial^2}{\partial c^2} \operatorname{Tr}_s [\exp(-\mathfrak{R}_u^2 + cN_{\mathbf{H}})]_{c=0}, \\ \Pi''_u &= -\bar{\partial} \frac{1}{2} \frac{\partial^2}{\partial c^2} \operatorname{Tr}_s [\exp(-\mathfrak{R}_u^2 + cN_{\mathbf{H}})]_{c=0}. \end{aligned}$$

Proof. Clearly

$$(5.51) \quad \begin{aligned} \Pi'_u &= \operatorname{Tr}_s [N_{\mathbf{H}} \exp(-\mathfrak{R}_u^2 + \operatorname{d}\bar{a} [\mathfrak{R}'_u, N_{\mathbf{H}}])]^{\operatorname{d}\bar{a}}, \\ \Pi''_u &= \operatorname{Tr}_s [N_{\mathbf{H}} \exp(-\mathfrak{R}_u^2 - \operatorname{d}a [\mathfrak{R}''_u, N_{\mathbf{H}}])]^{\operatorname{d}a}. \end{aligned}$$

Using (5.51), and proceeding as in [6, Theorem 4.6] (we are considering only generalized supertraces), we get (5.50). \square

Theorem 5.29 — As $u \rightarrow 0$,

$$(5.52) \quad \begin{aligned} \Phi\Theta_u &= (-\text{Td}'(M, g^M) + \dim M \text{Td}(TM, g^{TM}))(\text{Td}^{-1})'(N, g^N) + \mathcal{O}(u), \\ \Phi\Lambda_u &= \mathcal{O}(u), \\ \Phi\Pi'_u &= \mathcal{O}(u), \\ \Phi\Pi''_u &= \mathcal{O}(u). \end{aligned}$$

As $u \rightarrow +\infty$,

$$(5.53) \quad \begin{aligned} \Phi\Theta_u &= \frac{1}{2} \dim N (\text{Td}'(L, g^L) - (\dim L + \frac{\dim N}{2}) \text{Td}(L, g^L)) + \mathcal{O}(\frac{1}{\sqrt{u}}), \\ \Phi\Lambda_u &= \mathcal{O}(\frac{1}{\sqrt{u}}) \\ \Phi\Pi'_u &= \mathcal{O}(\frac{1}{\sqrt{u}}), \\ \Phi\Pi''_u &= \mathcal{O}(\frac{1}{\sqrt{u}}). \end{aligned}$$

Proof. Let π be the projection $N \rightarrow B$. Clearly $\nabla^{\Lambda(N^*)} + \sqrt{-1} \frac{\widehat{c}(Z)}{\sqrt{2}}$ is a superconnection on $\pi^*\Lambda(N^*)$. By proceeding as in [6, Theorems 4.8 and 4.9], we see that as $u \rightarrow 0$,

$$(5.54) \quad \Theta_u = - \left\{ \widehat{A}(R^M + dad\bar{a}) e^{-\frac{1}{2} \text{Tr}[R^M]} \left(\frac{-i}{2\pi}\right)^{\dim N} \int_N^{\Lambda(N^*)} \text{Tr}_s \left[N_{\mathbf{H}} \exp(-(\nabla^{\Lambda(N^*)} + \sqrt{-1} \frac{\widehat{c}}{\sqrt{2}}(Z))^2 - da\sqrt{-1} \frac{\widehat{c}}{\sqrt{2}}(z) - d\bar{a}\sqrt{-1} \frac{\widehat{c}}{\sqrt{2}}(\bar{z}) + dad\bar{a} \frac{\dim M}{2}) \right] \right\}^{dad\bar{a}} + \mathcal{O}(u).$$

Also, one has the easy formula

$$(5.55) \quad \begin{aligned} \text{Tr}_s \left[N_{\mathbf{H}} \exp(-(\nabla^{\Lambda(N^*)} + \sqrt{-1} \frac{\widehat{c}}{\sqrt{2}}(Z))^2 - da\sqrt{-1} \frac{\widehat{c}}{\sqrt{2}}(z) - d\bar{a}\sqrt{-1} \frac{\widehat{c}}{\sqrt{2}}(\bar{z}) + \frac{\dim M}{2} dad\bar{a}) \right] = \\ \left((1 + d\bar{a}i_{\bar{z}})(1 + dai_z) + \frac{\dim M}{2} dad\bar{a} \right) \text{Tr}_s \left[N_{\mathbf{H}} \exp(-(\nabla^{\Lambda(N^*)} + \sqrt{-1} \frac{\widehat{c}}{\sqrt{2}}(Z))^2) \right]. \end{aligned}$$

Let \widehat{A}' be the genus obtained from \widehat{A} as Td' is from Td in (2.36). Using (5.54), (5.55) and proceeding as in [6, proof of Theorem 4.8], we see that as $u \rightarrow 0$,

$$(5.56) \quad \Theta_u = (\widehat{A}'(R^M) + \frac{\dim M}{2} \widehat{A}(R^M)) e^{-\frac{1}{2} \text{Tr}[R^M]} (\text{Td}^{-1})'(-R^N) + \mathcal{O}(u).$$

Since $\text{Td}(-R^M) = \widehat{A}(R^M)e^{-\frac{1}{2}\text{Tr}[R^M]}$, we get

$$(5.57) \quad \text{Td}'(-R^M) = (-\widehat{A}'(R^M) + \frac{\dim M}{2}\widehat{A}(R^M))e^{-\frac{1}{2}\text{Tr}[R^M]}.$$

From (5.56), (5.57), we get the first identity in (5.52). The proof of the second identity is essentially the same and is left to the reader.

By proceeding as before, we see that as $u \rightarrow 0$,

$$(5.58) \quad \Pi'_u = \text{Td}(-R^M)\left(\frac{-i}{2\pi}\right)^{\dim N} \int_N \text{Tr}_s \left[N_{\mathbf{H}} \exp(-(\nabla^{\Lambda(N^*)} + \sqrt{-1}\frac{\widehat{c}(Z)}{\sqrt{2}})^2 - d\bar{a}\sqrt{-1}\frac{\widehat{c}(\bar{z})}{\sqrt{2}}) \right]^{d\bar{a}} + \mathcal{O}(u).$$

Using the following identity (which can be derived from (5.55)),

$$(5.59) \quad \text{Tr}_s \left[N_{\mathbf{H}} \exp(-(\nabla^{\Lambda(N^*)} + \sqrt{-1}\frac{\widehat{c}(Z)}{\sqrt{2}})^2 - d\bar{a}\sqrt{-1}\frac{\widehat{c}(\bar{z})}{\sqrt{2}}) \right]^{d\bar{a}} \\ = i_{\bar{z}} \text{Tr}_s \left[N_{\mathbf{H}} \exp(-(\nabla^{\Lambda(N^*)} + \sqrt{-1}\frac{\widehat{c}(Z)}{\sqrt{2}})^2) \right]$$

or the fact that the integrand in the right-hand side of (5.58) is odd in Z , we get the third identity in (5.52). The proof of the fourth identity in (5.52) is similar.

Now we establish (5.53). Clearly

$$(5.60) \quad \Theta_u = \frac{\partial}{\partial b} \text{Tr}_s \left[\exp \left(-\left(\frac{1}{2} \sum_1^{2m} (\nabla_{e_i} + \frac{1}{2} \langle (R^M - ibJdad\bar{a})Z, e_i \rangle) \right)^2 \right. \right. \\ \left. \left. + u \frac{|P^N Z|^2}{2} + \sqrt{u}S + \sqrt{-u}\frac{\widehat{c}}{\sqrt{2}}(AP^L Z) + da\sqrt{-1}\frac{\widehat{c}(P^N z)}{\sqrt{2}} + d\bar{a}\sqrt{-1}\frac{\widehat{c}(P^N \bar{z})}{\sqrt{2}} + \right. \right. \\ \left. \left. + \frac{1}{2} \text{Tr}[R^M] + R^{\Lambda(N^*)} + bN_{\mathbf{H}} \right) \right]_{b=0}^{dad\bar{a}} - \frac{\dim M}{2} \frac{\partial}{\partial b} \text{Tr}_s [\exp(-\mathcal{R}_u^2 + bN_{\mathbf{H}})]_{b=0}.$$

By [6, Theorem 7.7], as $u \rightarrow +\infty$

$$(5.61) \quad \frac{\partial}{\partial b} \text{Tr}_s [\exp(-\mathcal{R}_u^2 + bN_{\mathbf{H}})]_{b=0} = \frac{\dim N}{2} \text{Td}(-R^L) + \mathcal{O}\left(\frac{1}{\sqrt{u}}\right).$$

Let J_K be the differential operator $\frac{d}{dt}$ acting on S_1 . By using the notation and the techniques of [6, proof of Theorem 7.3], one finds that the first term in the right-hand

side of (5.60) is given by

$$(5.62) \quad -\frac{\partial}{\partial b} \left[e^{-\frac{1}{2} \text{Tr}[R^L] + b/2 \dim N} \det'_N (1 - (R^N + b)J_K^{-1} - uJ_K^{-2}) \right. \\ \left. \left[\det'_M (1 - (R^M + dad\bar{a})J_K^{-1} - uP^L A(J_K^2 - (R^N + b)J_K - u)^{-1} \right. \right. \\ \left. \left. AP^L J_K^{-1} - \frac{u}{2} (P^L A + daP^{\bar{N}} + d\bar{a}P^N)(J_K^2 - (R^N + b)J_K - u)^{-1} \right. \right. \\ \left. \left. (AP^L - daP^N - d\bar{a}P^{\bar{N}})J_K^{-1} - uP^N J_K^{-2} \right) \right]^{dad\bar{a}}.$$

The precise interpretation of (5.62) is that (5.62) is an infinite product over $J_K \in 2i\pi\mathbf{Z}^*$ of determinants over M or N (in [6], determinants over $M_{\mathbf{R}}$, $N_{\mathbf{R}}$ are considered, and this explains the power $1/2$).

By proceeding as in [6, Theorems 7.6 and 7.7], as $u \rightarrow +\infty$, the asymptotic expansion of (5.62) is given by

$$(5.63) \quad -\frac{1}{2} \dim N \widehat{A}'(R^L) e^{-\frac{1}{2} \text{Tr}(R^L)} + \mathcal{O}\left(\frac{1}{\sqrt{u}}\right).$$

From (5.60)-(5.63), we find that as $u \rightarrow +\infty$,

$$(5.64) \quad \Theta_u = \frac{\dim N}{2} \left(-\frac{\dim M}{2} \text{Td}(-R^L) - \widehat{A}'(R^L) e^{-1/2 \text{Tr}[R^L]} \right).$$

Using (5.57) and (5.64), we get the first identity in (5.53). An obvious modification of the previous argument shows that the last three identities hold.

The proof of our Theorem is completed. □

Remark 5.30. From (5.50), it is easy to give another proof of the last two identities in (5.52), (5.53), by showing that the limit as $u \rightarrow 0$ or $u \rightarrow +\infty$ of $\text{Tr}_s[\exp(-\mathfrak{B}_u^2 + cN_{\mathbf{H}})]$ is a closed form.

Put

$$(5.65) \quad \Theta_0 = \lim_{u \rightarrow 0} \Theta_u, \\ \Theta_\infty = \lim_{u \rightarrow +\infty} \Theta_u.$$

The forms Θ_0 and Θ_∞ have been calculated in (5.52), (5.53). They are ∂ and $\bar{\partial}$ closed.

Theorem 5.31 — *The following identities hold,*

$$(5.66) \quad \Phi \bar{\partial} \int_0^{+\infty} \Pi'_u \frac{du}{u} + \Phi \partial \int_0^{+\infty} \Pi''_u \frac{du}{u} \\ - \frac{\bar{\partial} \partial}{2i\pi} \left(\int_0^1 \Phi(\Theta_u - \Theta_0) \frac{du}{u} + \int_1^{+\infty} \Phi(\Theta_u - \Theta_\infty) \frac{du}{u} \right) \\ = \dim M (\text{Td}(L, g^L) - \text{Td}(M, g^M) \text{Td}^{-1}(N, g^N)) \\ - \text{Td}'(L, g^L) + \text{Td}'(M, g^M) \text{Td}^{-1}(N, g^N) + \text{Td}(M, g^M) (\text{Td}^{-1})'(N, g^N).$$

Proof. By Proposition 5.28, we find that

$$(5.67) \quad \bar{\partial} \Pi'_u + \partial \Pi''_u = \bar{\partial} \partial \frac{\partial^2}{\partial c^2} \text{Tr}_s [\exp(-\mathfrak{R}_u^2 + cN_{\mathbf{H}})]_{c=0}.$$

From (5.33), (5.49), we find easily that

$$(5.68) \quad \Theta_u = - \text{Tr}_s \left[N_{\mathbf{H}} \exp \left(- \left(dad\bar{a} L_{iJMZ} + \left(\mathfrak{R}_u + \frac{c(idad\bar{a}J^M Z)}{2\sqrt{2}} \right)^2 \right) \right) \right]^{dad\bar{a}} \\ - \dim M \text{Tr}_s [N_{\mathbf{H}} \exp(-\mathfrak{R}_u^2)] + \text{Tr}_s [N_{\mathbf{H}} \exp(-\mathfrak{R}_u^2 + dad\bar{a}N_{\mathbf{H}})]^{dad\bar{a}} \\ - \text{Tr}_s \left[N_{\mathbf{H}} \exp \left(- \left(\mathfrak{R}_u^2 + 2dau \frac{\partial \mathfrak{R}_u''}{\partial u} + 2d\bar{a}u \frac{\partial B'_u}{\partial u} \right) \right) \right]^{dad\bar{a}}.$$

By (5.35)

$$(5.69) \quad \bar{\partial} \partial \text{Tr}_s \left[\frac{N_{\mathbf{H}}}{u} \exp \left(- \left(dad\bar{a} L_{iJMZ} + \left(\mathfrak{R}_u + \frac{c(idad\bar{a}J^M Z)}{2\sqrt{2}} \right)^2 \right) \right) \right]^{dad\bar{a}} \\ = \frac{\partial}{\partial u} \text{Tr}_s \left[\exp \left(- \left(dad\bar{a} L_{iJMZ} + \left(\mathfrak{R}_u + \frac{c(idad\bar{a}J^M Z)}{2\sqrt{2}} \right)^2 \right) \right) \right]^{dad\bar{a}}.$$

By Theorem 5.11,

$$(5.70) \quad \bar{\partial} \partial \text{Tr}_s \left[\frac{N_{\mathbf{H}}}{u} \exp(-\mathfrak{R}_u^2) \right] = \frac{\partial}{\partial u} \text{Tr}_s [\exp(-\mathfrak{R}_u^2)].$$

Also one has the trivial,

$$(5.71) \quad \text{Tr}_s [N_{\mathbf{H}} \exp(-\mathfrak{R}_u^2 + dad\bar{a}N_{\mathbf{H}})]^{dad\bar{a}} = \frac{\partial^2}{\partial c^2} \text{Tr}_s [\exp(-\mathfrak{R}_u^2 + cN_{\mathbf{H}})]_{c=0}.$$

By Proposition 5.26,

$$(5.72) \quad \bar{\partial} \partial \frac{\partial}{\partial u} \frac{1}{2} \frac{\partial^2}{\partial c^2} \text{Tr}_s [\exp(-\mathfrak{R}_u^2 + cN_{\mathbf{H}})]_{c=0} = \\ - \bar{\partial} \partial \text{Tr}_s \left[\frac{N_{\mathbf{H}}}{u} \exp(-\mathfrak{R}_u^2 - da2u \frac{\partial \mathfrak{R}_u''}{\partial u} - d\bar{a}2u \frac{\partial \mathfrak{R}_u''}{\partial u}) \right]^{dad\bar{a}}.$$

From (5.67)-(5.72), we obtain

$$(5.73) \quad \frac{1}{u} (\bar{\partial}\Pi'_u + \partial\Pi''_u - \bar{\partial}\partial\Theta_u) = \\ \frac{\partial}{\partial u} \text{Tr}_s \left[\exp \left(- \left(dad\bar{a}L_{iJM}Z + \left(\mathfrak{R}_u + \frac{c(idad\bar{a}J^M Z)}{2\sqrt{2}} \right)^2 \right) \right) \right] \\ + \dim M \frac{\partial}{\partial u} \text{Tr}_s [\exp(-\mathfrak{R}_u^2)] - \bar{\partial}\partial \frac{\partial}{\partial u} \frac{1}{2} \frac{\partial^2}{\partial c^2} \text{Tr}_s [\exp(-\mathfrak{R}_u^2 + cN_{\mathbf{H}})]_{c=0} .$$

As we just saw, Θ_0 and Θ_∞ are ∂ and $\bar{\partial}$ closed. Moreover by (5.50), (5.52), (5.53), or by a simple direct proof, the limit as $u \rightarrow 0$ or $u \rightarrow +\infty$ of $\frac{1}{2} \frac{\partial^2}{\partial c^2} \text{Tr}_s [\exp(-\mathfrak{R}_u^2 + cN_{\mathbf{H}})]_{c=0}$ is ∂ and $\bar{\partial}$ closed. By Theorem 5.11 and its extension stated after (5.36), and by (5.73), we get (5.66). The proof of our Theorem is completed. \square

5.9 A conjugation formula

If $X \in M_{\mathbf{R}}$ let $X^{(1,0)}, X^{(0,1)}$ be the component of X in M, \bar{M} , so that $X = X^{(1,0)} + X^{(0,1)}$.

Proposition 5.32 — For $u \geq 0$, the following identity holds

$$(5.74) \quad \exp \left(-\frac{1}{2} da \langle AP^L \bar{z}, P^N z \rangle - \frac{1}{2} d\bar{a} \langle AP^L z, P^N \bar{z} \rangle + \frac{c}{\sqrt{2}} (AP^L Z) \right. \\ \left. + da \frac{c}{\sqrt{2}} (P^N z) + d\bar{a} \frac{c}{\sqrt{2}} (P^N \bar{z}) - \frac{\langle R^M P^N Z, P^L Z \rangle}{2} \right) \\ \left(-\frac{1}{2} \sum_1^{2m} (\nabla_{e_i} + \frac{1}{2} \langle (R^M - iJ^M dad\bar{a})Z, e_i \rangle)^2 + \frac{u |P^N Z|^2}{2} + \sqrt{u} S \right. \\ \left. + \sqrt{-u} \frac{\hat{c}}{\sqrt{2}} (AP^L Z) + da \sqrt{-u} \frac{\hat{c}}{\sqrt{2}} (P^N z) \right. \\ \left. + d\bar{a} \sqrt{-u} \frac{\hat{c}(P^N \bar{z})}{\sqrt{2}} - dad\bar{a} \frac{\dim M}{2} + \frac{1}{2} \text{Tr} [R^M] + R^{\Lambda(N^*)} \right) \\ \exp \left(\frac{1}{2} da \langle AP^L \bar{z}, P^N z \rangle + \frac{1}{2} d\bar{a} \langle AP^L z, P^N \bar{z} \rangle - \frac{c}{\sqrt{2}} (AP^L Z) \right. \\ \left. - da \frac{c}{\sqrt{2}} (P^N z) - d\bar{a} \frac{c}{\sqrt{2}} (P^N \bar{z}) + \frac{\langle R^M P^N Z, P^L Z \rangle}{2} \right)$$

$$\begin{aligned}
&= -\frac{1}{2} \sum_1^{2m} \left(\nabla_{e_i} + \frac{1}{2} \langle (R^M - P^L A^2 P^L - \sqrt{-1} P^L J^M P^L \text{dad}\bar{a}) Z, e_i \rangle \right. \\
&\quad + \frac{1}{2} \langle R^M P^N Z, P^L e_i \rangle - \frac{1}{2} \langle R^M P^L Z, P^N e_i \rangle \\
&\quad + da \langle AP^L e_i, P^N z \rangle + d\bar{a} \langle AP^L e_i, P^N \bar{z} \rangle \\
&\quad \left. - \frac{c(AP^L e_i)}{\sqrt{2}} + \frac{1}{\sqrt{2}} c(P^N e_i^{(1,0)}) da + \frac{1}{\sqrt{2}} c(P^N e_i^{(0,1)}) d\bar{a} \right)^2 \\
&\quad + \frac{u |P^N Z|^2}{2} + \sqrt{u} S - da d\bar{a} \frac{\dim M}{2} + \frac{1}{2} \text{Tr} [R^M] + R^{\Lambda(N^*)}.
\end{aligned}$$

Proof. When $da = d\bar{a} = 0$, formula (5.74) is exactly the second identity in (5.16). Put

$$(5.75) \quad K = \frac{c}{\sqrt{2}} (AP^L Z) + da \frac{c}{\sqrt{2}} (P^N z) + d\bar{a} \frac{c}{\sqrt{2}} (P^N \bar{z}).$$

Observe that if $X \in N_{\mathbf{R}}$,

$$(5.76) \quad \left[K, \frac{c}{\sqrt{2}} (X) \right] = \langle AP^L Z, X \rangle - da \langle P^N z, X \rangle - d\bar{a} \langle P^N \bar{z}, X \rangle.$$

From (5.76), we deduce that

$$(5.77) \quad \begin{aligned} &\exp(K) \left(S + \frac{\hat{c}}{\sqrt{2}} (AP^L Z) + da \frac{\hat{c}}{\sqrt{2}} (P^N z) + d\bar{a} \frac{\hat{c}}{\sqrt{2}} (P^N \bar{z}) \right) \\ &\exp(-K) = S. \end{aligned}$$

Also

$$(5.78) \quad \begin{aligned} [K, \nabla_{e_i}] &= -\frac{c}{\sqrt{2}} (AP^L e_i) - da \frac{c}{\sqrt{2}} (P^N e_i^{(1,0)}) - d\bar{a} \frac{c}{\sqrt{2}} (P^N e_i^{(0,1)}), \\ [K, [K, \nabla_{e_i}]] &= -\langle AP^L Z, AP^L e_i \rangle + \langle AP^L \bar{z}, P^N e_i \rangle da \\ &\quad + \langle AP^L z, P^N e_i \rangle d\bar{a} + da \langle P^N z, AP^L e_i \rangle + d\bar{a} \langle P^N \bar{z}, AP^L e_i \rangle \\ &\quad + da d\bar{a} \left(-\langle P^N z, P^N e_i^{(0,1)} \rangle + \langle P^N \bar{z}, P^N e_i^{(1,0)} \rangle \right). \end{aligned}$$

Also the higher commutators in (5.78) vanish. From (5.78), we get

$$(5.79) \quad \begin{aligned} \exp(K) \nabla_{e_i} \exp(-K) &= \nabla_{e_i} - \frac{c}{\sqrt{2}} (AP^L e_i) - da \frac{c}{\sqrt{2}} (P^N e_i^{(1,0)}) \\ &\quad - d\bar{a} \frac{c}{\sqrt{2}} (P^N e_i^{(0,1)}) + \frac{1}{2} (\langle -P^L A^2 P^L Z, e_i \rangle) \\ &\quad - \frac{1}{2} da (\langle AP^L \bar{z}, P^N e_i \rangle - \langle AP^L e_i, P^N z \rangle) - \frac{1}{2} d\bar{a} (\langle AP^L z, P^N e_i \rangle - \langle AP^L e_i, P^N \bar{z} \rangle) \\ &\quad + \frac{1}{2} \langle \sqrt{-1} J^M \text{dad}\bar{a} P^N Z, P^N e_i \rangle. \end{aligned}$$

From (5.77)-(5.79), we get (5.74). The proof of our Proposition is completed. \square

6. A proof of Theorem 0.1

The purpose of this Chapter is to establish Theorem 0.1, which is an identity relating the higher analytic torsion forms $T(\omega^V, g^\varepsilon)$ and $T(\omega^W, g^\eta)$ to integrals along the fibre X of certain Bott-Chern currents on W .

In (4.26), we established an identity of forms in P^S , $\sum_{k=1}^4 I_k^0 = \Phi(\bar{\partial}\mu^0 + \partial\nu^0) - \frac{\bar{\partial}\partial}{i\pi}\Phi\lambda^0$, these forms depending on ε, A, T_0 . In this Chapter, we study the various terms in this equality, by making $A \rightarrow +\infty$ (step α), $T_0 \rightarrow +\infty$ (step β), $\varepsilon \rightarrow 0$ (step γ). Divergences appear at one or more of these stages. The final identity $\sum_{k=1}^4 I_k^3 \in P^{S,0}$ will then be shown to be equivalent to Theorem 0.1.

When S is a point (which is the case studied in [19]), $P^{S,0} = \{0\}$. So in [19], the right-hand side of the above equality is identically 0. Also, in general, $P^{S,0}$ is not closed under uniform convergence. Finally, as explained in the introduction, our purpose is to obtain a local universal equality in $P^S/P^{S,0}$. So in contrast to [19], we have to study in much detail the right-hand side of the equality.

The organization of this Chapter is closely related to the organization of [19, Section 6]. As in [19], we state several intermediate results, whose proof is delayed to Chapters 7-13.

The Chapter is organized as follows. In Section 6.1, we state our main Theorem. In Section 6.2, we introduce a rescaled metric on ξ , which depends on a parameter $T > 0$. In Section 6.3, we state seven intermediate results concerning the left-hand side of the equality. In Section 6.4, we study the asymptotics of the I_k^0 's. In Section 6.5, we summarize the divergences in the right-hand side of the equality. In Section 6.6, we state five intermediate results needed in the study of the right-hand side of the above equality. In Section 6.7, we calculate the asymptotics of the right-hand side. In Section 6.8, we crosscheck our computations, by verifying that the diverging terms of both sides of the equality coincide. In Section 6.9, we obtain a local equality in $P^S/P^{S,0}$. Finally, in Section 6.10, we show that this equality is just Theorem 0.1.

The general outlook of the computations of this Chapter being quite similar to

[19, Section 6], the reader is referred to [19] for a more detailed discussion of some computations. Also as explained at the end of Chapter 6, if S is compact and Kähler, and if we are just interested in a non local equality in $P^S/P^{S,0}$, the reader can skip the rather heavy Sections 6.6-6.8.

In this Chapter, we use the assumptions and notation of Chapters 3, 4 and 5.

6.1 The main Theorem

Consider the exact sequence of holomorphic Hermitian vector bundles on W

$$(6.1) \quad 0 \rightarrow TY \rightarrow TX|_W \rightarrow N_{Y/X} \rightarrow 0.$$

Let $\widetilde{\text{Td}}(TY, TX|_W, g^{TX|_W}) \in P^W/P^{W,0}$ be the Bott-Chern class constructed in [13, Theorem 1.29] such that

$$(6.2) \quad \frac{\bar{\partial}\partial}{2i\pi} \widetilde{\text{Td}}(TY, TX|_W, g^{TX|_W}) = \text{Td}(TX|_W, g^{TX|_W}) - \text{Td}(TY, g^{TY}) \text{Td}(N_{Y/X}, g^{N_{Y/X}}).$$

Note that the construction of [13] is local and universal.

Recall that by (3.12), we have the canonical isomorphism of holomorphic \mathbf{Z} -graded vector bundles on S

$$(6.3) \quad H(X, \xi|_X) \simeq H(Y, \eta|_Y).$$

Also, in Sections 2.6 and 3.2, smooth Hermitian metrics $g^{H(X, \xi|_X)}$ and $h^{H(Y, \eta|_Y)}$ were constructed on $H(X, \xi|_X)$ and $H(Y, \eta|_Y)$. Because of (6.3), we may regard $g^{H(X, \xi|_X)}$ and $g^{H(Y, \eta|_Y)}$ as metrics on the same \mathbf{Z} -graded bundle $H(Y, \eta|_Y)$.

For $p \in \mathbf{N}$, let $\widetilde{\text{ch}}(H(Y, \eta|_Y), g^{H(X, \xi|_X)}, g^{H(Y, \eta|_Y)}) \in P^S/P^{S,0}$ be the Bott-Chern class of [13, Theorem 1.29], such that

$$(6.4) \quad \frac{\bar{\partial}\partial}{2i\pi} \widetilde{\text{ch}}(H(Y, \eta|_Y), g^{H(X, \xi|_X)}, g^{H(Y, \eta|_Y)}) = \text{ch}(H(Y, \eta|_Y), g^{H(Y, \eta|_Y)}) - \text{ch}(H(X, \xi|_X), g^{H(X, \xi|_X)}).$$

Let $\zeta(s) = \sum_1^{+\infty} \frac{1}{n^s}$ be the Riemann zeta function. Now we introduce the Gillet-Soulé power series R [26].

Definition 6.1. Set

$$(6.5) \quad R(x) = \sum_{\substack{n \geq 1 \\ n \text{ odd}}} \left(\sum_1^n \frac{1}{j} + 2 \frac{\zeta'(-n)}{\zeta(-n)} \right) \zeta(-n) \frac{x^n}{n!}.$$

We identify R with the corresponding additive genus.

The main result of this paper is stated in Theorem 0.1. For convenience, we state again this result, which extends [19, Theorem 6.1].

Recall that by Remark 3.11, the integral along the fibre $\int_X \text{Td}(TX, g^{TX})T(\xi, g^\xi)$ lies in P^S .

Theorem 6.2 — *The following identities hold,*

$$\begin{aligned}
 (6.6) \quad & \widetilde{\text{ch}}(H^{(Y, \eta|_Y)}, g^{H(X, \xi|_X)}, g^{H(Y, \eta|_Y)}) - T(\omega^W, g^\eta) + T(\omega^V, g^\xi) \\
 &= \int_X \text{Td}(TX, g^{TX})T(\xi, g^\xi) - \int_Y \frac{\widetilde{\text{Td}}(TY, TX|_W, g^{TX|_W})}{\text{Td}(N_{Y/X}, g^{N_{Y/X}})} \text{ch}(\eta, g^\eta) \\
 &+ \int_Y \text{Td}(TY)R(N_{Y/X}) \text{ch}(\eta) \quad \text{in} \quad P^S/P^{S,0}, \\
 &\widetilde{\text{ch}}(H^{(Y, \eta|_Y)}, g^{H(X, \xi|_X)}, g^{H(Y, \eta|_Y)}) - T(\omega^W, g^\eta) + T(\omega^V, g^\xi) \\
 &= \int_X \text{Td}(TX, g^{TX})T(\xi, g^\xi) - \int_Y \frac{\widetilde{\text{Td}}(TY, TX|_W, g^{TX|_W})}{\text{Td}(N_{Y/X}, g^{N_{Y/X}})} \text{ch}(\eta, g^\eta) \\
 &+ \int_X \text{Td}(TX)R(TX) \text{ch}(\xi) - \int_Y \text{Td}(TY)R(TY) \text{ch}(\eta) \quad \text{in} \quad P^S/P^{S,0}.
 \end{aligned}$$

6.2 A rescaled metric on E

By the anomaly formulas of [18] stated in Theorem 2.24, one verifies easily that we only need to establish Theorem 6.2 for one single choice of ω^W . In the sequel, we will assume that $\omega^W = i^*\omega^V$, and we will prove Theorem 6.2 in this case.

Definition 6.3. For $T > 0$, we denote by $\langle \cdot, \cdot \rangle_T$ the Hermitian product on E associated to the metrics $g^{TX}, g^{\xi_0}, \frac{g^{\xi_1}}{T^2}, \dots, \frac{g^{\xi_m}}{T^{2m}}$ on TX, ξ_0, \dots, ξ_m . Set

$$(6.7) \quad K_T = \left\{ s \in E, (\bar{\partial}^X + v)s = 0, (\bar{\partial}^{X^*} + T^2 v^*)s = 0 \right\}.$$

Let P_T be the orthogonal projection operator from E on K_T with respect to $\langle \cdot, \cdot \rangle_T$.

In (3.24), we saw that for any $T > 0$, there is a canonical isomorphism of \mathbf{Z} -graded vector bundles

$$(6.8) \quad K_T \cong H(X, \xi|_X).$$

Let $g_T^{H(X, \xi|_X)}$ be the metric on $H(X, \xi|_X)$ inherited from the metric $\langle \cdot, \cdot \rangle_T$ restricted to K_T . Let $\nabla_T^{H(X, \xi|_X)}$ be the holomorphic Hermitian connection on $(H(X, \xi|_X), g_T^{H(X, \xi|_X)})$.

Put

$$(6.9) \quad \begin{aligned} D^X &= \bar{\partial}^X + \bar{\partial}^{X*}, \\ D^Y &= \bar{\partial}^Y + \bar{\partial}^{Y*}. \end{aligned}$$

Recall that $V = v + v^*$. For $T > 0$, set

$$(6.10) \quad \tilde{K}_T = \{s \in E, (D^X + TV)s = 0\}.$$

Let \tilde{P}_T be the orthogonal projection operator from E on \tilde{K}_T with respect to the Hermitian product $\langle \cdot, \cdot \rangle = \langle \cdot, \cdot \rangle_1$ on E .

Then we have the easy formula in [19, eq. (6.5)]

$$(6.11) \quad T^{-N_{\mathbf{H}}}(\bar{\partial}^X + v + \bar{\partial}^{X*} + T^2v^*)T^{N_{\mathbf{H}}} = D^X + TV.$$

By (6.11), we get

$$(6.12) \quad \tilde{P}_T = T^{-N_{\mathbf{H}}}P_T T^{N_{\mathbf{H}}}.$$

The map $s \in K_T \rightarrow T^{-N_{\mathbf{H}}}s \in \tilde{K}_T$ is an isomorphism of \mathbf{Z} -graded Hermitian vector bundles. So \tilde{K}_T is also isomorphic to $H(X, \xi|_X)$.

The operators $P_T N_{\mathbf{V}}^X P_T$ and $P_T N_{\mathbf{H}} P_T$ act on K_T . We still denote by $P_T N_{\mathbf{V}}^X P_T$ and $P_T N_{\mathbf{H}} P_T$ the corresponding operators acting on $H(X, \xi|_X) \simeq H(Y, \eta|_Y)$.

Let Q be the orthogonal projection operator from F on $K' = \ker(D^Y)$.

6.3 The left-hand side of (4.26): seven intermediate results

Now we state seven intermediary results contained in Theorems 6.4-6.10, which are the obvious extension of [19, Theorems 6.3-6.9]. They will permit us to study the left-hand side of (4.26). The proofs of Theorems 6.5-6.10 are deferred to Chapters 7-13.

We use the same notation as in Theorem 2.17. Also we use the notation of Chapter 5 with respect to the exact sequence of holomorphic Hermitian vector bundles (6.1) on W .

Theorem 6.4 — *There are forms D_{-1}^V, D_0^V in P^S that as $u \rightarrow 0$,*

$$(6.13) \quad \Phi \operatorname{Tr}_s \left[\bar{N}_u^V \exp(-\bar{B}_u^{V,2}) \right] = \frac{D_{-1}^V}{u} + D_0 + \mathcal{O}(u).$$

Moreover

$$(6.14) \quad \begin{aligned} D_{-1}^V &= \int_X \frac{\omega^V}{2\pi} \operatorname{Td}(TX, g^{TX}) \operatorname{ch}(\xi, g^\xi), \\ D_0^V &= \int_X (\dim X \operatorname{Td}(TX) - \operatorname{Td}'(TX)) \operatorname{ch}(\xi) \\ &\quad - \int_X \operatorname{Td}(TX) \operatorname{ch}'(\xi) \quad \text{in} \quad P^S/P^{S,0}. \end{aligned}$$

There are forms C_{-1}^W, C_0^W in P^S such that as $u \rightarrow 0$,

$$(6.15) \quad \mathrm{Tr}_s [N_u^W \exp(-B_u^{W,2})] = \frac{C_{-1}^W}{u} + C_0^W + \mathcal{O}(u).$$

Moreover

$$(6.16) \quad \begin{aligned} C_{-1}^W &= \int_Y \frac{\omega^W}{2\pi} \mathrm{Td}(TY, g^{TY}) \mathrm{ch}(\eta, g^\eta), \\ C_0^W &= \int_Y (\dim Y \mathrm{Td}(TY) - \mathrm{Td}'(TY)) \mathrm{ch}(\eta) \quad \text{in } P^S/P^{S,0}. \end{aligned}$$

Proof. Our Theorem follows from Theorems 2.17 and 3.5. \square

Theorem 6.5 — For any compact set $K \subset S$, for any $u_0 > 0$, there exist $C > 0$, $\delta \in]0, 1]$ such that for $u \geq u_0$, $T \geq 1$,

$$(6.17) \quad \begin{aligned} \left| \mathrm{Tr}_s [(N_{u^2}^V - N_{\mathbf{H}}) \exp(-B_{u,T}^2)] - \mathrm{Tr}_s [N_{u^2}^W \exp(-B_{u^2}^{W,2})] \right| &\leq \frac{C}{T^\delta} \quad \text{on } K, \\ \left| \mathrm{Tr}_s [N_{\mathbf{H}} \exp(-B_{u,T}^2)] - \frac{1}{2} \dim N_{Y/X} \mathrm{Tr}_s [\exp(-B_{u^2}^{W,2})] \right| &\leq \frac{C}{T^\delta} \quad \text{on } K. \end{aligned}$$

Theorem 6.6 — For any compact set $K \subset S$, there exist $C > 0$ such that for $u \geq 1$, $T \geq 1$,

$$(6.18) \quad \begin{aligned} \left| \mathrm{Tr}_s [N_{u^2}^V \exp(-B_{u,T}^2)] - \mathrm{Tr}_s [P_T N_{\mathbf{V}}^X P_T \exp(-\nabla_T^{H(X, \xi|_X), 2})] \right| &\leq \frac{C}{u} \quad \text{on } K, \\ \left| \mathrm{Tr}_s [N_{\mathbf{H}} \exp(-B_{u,T}^2)] - \mathrm{Tr}_s [P_T N_{\mathbf{H}} P_T \exp(-\nabla_T^{H(X, \xi|_X), 2})] \right| &\leq \frac{C}{u} \quad \text{on } K. \end{aligned}$$

Theorem 6.7 — For any compact set $K \subset S$, there exist $C > 0$, $\gamma \in]0, 1]$, such that for $u \in]0, 1]$, $0 \leq T \leq 1/u$,

$$(6.19) \quad \begin{aligned} \left| \Phi \mathrm{Tr}_s [N_{\mathbf{H}} \exp(-A_{u,T}^2)] - \int_X \mathrm{Td}(TX, g^{TX}) \Phi \mathrm{Tr}_s [N_{\mathbf{H}} \exp(-C_{T^2}^2)] \right| \\ \leq C(u(1+T))^\gamma \quad \text{on } K. \end{aligned}$$

For any compact set $K \subset S$, there exists $C' > 0$ such that for $u \in]0, 1]$, $0 \leq T \leq 1$,

$$(6.20) \quad \left| \mathrm{Tr}_s [N_{\mathbf{H}} \exp(-A_{u,T}^2)] - \mathrm{Tr}_s [N_{\mathbf{H}} \exp(-A_{u,0}^2)] \right| \leq C' T \quad \text{on } K.$$

Theorem 6.8 — For any $T > 0$, the following identity holds,

$$(6.21) \quad \lim_{u \rightarrow 0} \Phi \mathrm{Tr}_s [N_{\mathbf{H}} \exp(-A_{u,T/u}^2)] = \int_Y \Phi \mathrm{Tr}_s [N_{\mathbf{H}} \exp(-\mathcal{B}_{T^2}^2)] \mathrm{ch}(\eta, g^\eta).$$

Theorem 6.9 — For any compact set $K \subset S$, there exist $C > 0$, $\delta \in]0, 1]$, such that for $u \in]0, 1]$, $T \geq 1$,

$$(6.22) \quad \left| \mathrm{Tr}_s [N_{\mathbf{H}} \exp(-A_{u,T/u}^2)] - \frac{1}{2} \dim N_{Y/X} \mathrm{Tr}_s [\exp(-B_{u^2}^{W,2})] \right| \leq \frac{C}{T^\delta} \quad \text{on } K.$$

Let Y_1, \dots, Y_d be the connected components of the fibre Y . Then we have the local holomorphic splitting

$$(6.23) \quad H(Y, \eta|_Y) = \bigoplus_{j=1}^d H(Y_j, \eta|_{Y_j})$$

and the splitting (6.23) is orthogonal with respect to $g^{H(Y, \eta|_Y)}$. We will write metrics on $H(Y, \eta|_Y)$ in matrix form with respect to the splitting (6.23).

Recall that since $H(X, \xi|_X) \simeq H(Y, \eta|_Y)$, the metric $g_T^{H(X, \xi|_X)}$ can be considered as a metric on $H(Y, \eta|_Y)$.

In the sequel, we will write that a smooth function f on S is $\mathcal{O}(T^{-\infty})$ as $T \rightarrow +\infty$, if for any compact set $K \subset S$, $k \in \mathbf{N}$, $p \in \mathbf{N}$, there is $C > 0$ such that if $T \geq 1$, the sup over K of f and its derivatives of order $\leq p$ is dominated by $\frac{C}{T^k}$.

Theorem 6.10 — As $T \rightarrow +\infty$,

$$(6.24) \quad g_T^{H(X, \xi|_X)} = \begin{bmatrix} T^{-\dim N_{Y_1/X}} \left(g^{H(Y, \eta|_Y)} + \mathcal{O}\left(\frac{1}{\sqrt{T}}\right) \right) & & & \\ & \ddots & & \\ & & \mathcal{O}(T^{-\infty}) & \\ & \mathcal{O}(T^{-\infty}) & & \\ & & & T^{-\dim N_{Y_d/X}} \left(g^{H(Y_d, \eta|_{Y_d})} + \mathcal{O}\left(\frac{1}{\sqrt{T}}\right) \right) \end{bmatrix}$$

Theorems 6.5 and 6.6 will be proved in Chapters 8 and 9, Theorem 6.10 in Chapter 10, Theorem 6.7 in Chapter 11, Theorem 6.8 in Chapter 12, and Theorem 6.9 in Chapter 13.

6.4 The asymptotics of the I_k^0 's

Recall that by (4.18),

$$(6.25) \quad I_k^0 = \int_{\Gamma_k} \Phi \beta \quad , \quad 1 \leq k \leq 4.$$

By (4.26),

$$(6.26) \quad \sum_{k=1}^4 I_k^0 = \Phi(\bar{\partial}\mu^0 + \partial\nu^0) - \frac{\bar{\partial}\partial}{i\pi} \Phi\lambda^0.$$

In the discussion which follows, we will assume for simplicity that S is compact. If S is non compact, the various constants $C > 0$ depend explicitly on the compact set $K \subset S$ on which the given estimate is valid.

The term I_1^0

Clearly

$$(6.27) \quad I_1^0 = \int_{\varepsilon}^A \Phi \operatorname{Tr}_s [(N_{u^2}^V - N_{\mathbf{H}}) \exp(-B_{u, T_0}^2)] \frac{du}{u}.$$

$\alpha)$ $A \rightarrow +\infty$

By the obvious analogue of Theorem 2.20, as $A \rightarrow +\infty$

$$(6.28) \quad \begin{aligned} I_1^0 - \Phi \operatorname{Tr}_s [(N_{\mathbf{V}}^X - N_{\mathbf{H}}) \exp(-\nabla_{T_0}^{H(X, \xi|x), 2})] \log(T_0) \\ \rightarrow I_1^1 = \int_{\varepsilon}^1 \Phi \operatorname{Tr}_s [(N_{u^2}^V - N_{\mathbf{H}}) \exp(-B_{u, T_0}^2)] \frac{du}{u} \\ + \int_1^{+\infty} \Phi \left(\operatorname{Tr}_s [(N_{u^2}^V - N_{\mathbf{H}}) \exp(-B_{u, T_0}^2)] \right. \\ \left. - \operatorname{Tr}_s [(N_{\mathbf{V}}^X - N_{\mathbf{H}}) \exp(-\nabla_{T_0}^{H(X, \xi|x), 2})] \right) \frac{du}{u}. \end{aligned}$$

$\beta)$ $T_0 \rightarrow +\infty$

By Theorem 6.5, as $T_0 \rightarrow +\infty$

$$(6.29) \quad \begin{aligned} \int_{\varepsilon}^1 \Phi \operatorname{Tr}_s [(N_{u^2}^V - N_{\mathbf{H}}) \exp(-B_{u, T_0}^2)] \frac{du}{u} \\ \rightarrow \int_{\varepsilon}^1 \Phi \operatorname{Tr}_s [N_{u^2}^W \exp(-B_{u^2}^{W, 2})] \frac{du}{u}. \end{aligned}$$

By Theorem 6.6, for $1 \leq u < +\infty$, $T_0 \geq 1$,

$$(6.30) \quad \begin{aligned} |\operatorname{Tr}_s [(N_{u^2}^V - N_{\mathbf{H}}) \exp(-B_{u, T_0}^2)] \\ - \operatorname{Tr}_s [(N_{\mathbf{V}}^X - N_{\mathbf{H}}) \exp(-\nabla_{T_0}^{H(X, \xi|x), 2})]| \leq \frac{C}{u}. \end{aligned}$$

Also since the identification (3.12) preserves the \mathbf{Z} -grading,

$$(6.31) \quad \begin{aligned} \operatorname{Tr}_s [(N_{\mathbf{V}}^X - N_{\mathbf{H}}) \exp(-\nabla_{T_0}^{H(X, \xi|x), 2})] = \\ \operatorname{Tr}_s [N_{\mathbf{V}}^Y \exp(-\nabla_{T_0}^{H(X, \xi|x), 2})]. \end{aligned}$$

Let $\nabla_{T_0}^{H(Y, \eta|Y)}$ be the holomorphic Hermitian connection on $H(Y, \eta|Y)$ associated to the metric $g_{T_0}^{H(X, \xi|x)}$. Using (3.12), we find that $\nabla_{T_0}^{H(X, \xi|x)}$ corresponds to $\nabla_{T_0}^{H(Y, \eta|Y)}$.

By Theorem 6.10, as $T_0 \rightarrow +\infty$,

$$(6.32) \quad \nabla_{T_0}^{H(Y, \eta|Y)} \rightarrow \nabla^{H(Y, \eta|Y)}.$$

Using Theorems 6.5 and 6.6 and (6.31)-(6.32), we see that as $T_0 \rightarrow +\infty$,

$$(6.33) \quad \int_1^{+\infty} \Phi \left(\text{Tr}_s \left[(N_{u^2}^V - N_{\mathbf{H}}) \exp(-B_{u,T_0}^2) \right] - \right. \\ \left. \text{Tr}_s \left[(N_{\mathbf{V}}^X - N_{\mathbf{H}}) \exp(-\nabla_{T_0}^{H(X,\xi|x),2}) \right] \right) \frac{du}{u} \\ \rightarrow \int_1^{+\infty} \Phi \left(\text{Tr}_s \left[N_{u^2}^W \exp(-B_{u^2}^{W,2}) \right] - \right. \\ \left. \text{Tr}_s \left[N_{\mathbf{V}}^Y \exp(-\nabla^{H(Y,\eta|y),2}) \right] \right) \frac{du}{u}.$$

From (6.28), (6.29), (6.33), we find that as $T_0 \rightarrow +\infty$,

$$(6.34) \quad I_1^1 \rightarrow I_1^2 = \int_{\varepsilon}^1 \Phi \text{Tr}_s \left[N_{u^2}^W \exp(-B_{u^2}^{W,2}) \right] \frac{du}{u} \\ + \int_1^{+\infty} \Phi \left(\text{Tr}_s \left[N_{u^2}^W \exp(-B_{u^2}^{W,2}) \right] \right. \\ \left. - \text{Tr}_s \left[N_{\mathbf{V}}^Y \exp(-\nabla^{H(Y,\eta|y),2}) \right] \right) \frac{du}{u}.$$

$\gamma)$ $\varepsilon \rightarrow 0$

Using Theorem 6.4, we find that as $\varepsilon \rightarrow 0$,

$$(6.35) \quad I_1^2 - \frac{1}{2} C_{-1}^W \frac{1}{\varepsilon^2} + C_0^W \log(\varepsilon) \rightarrow I_1^3 = \\ = \int_0^1 \left\{ \Phi \text{Tr}_s \left[N_{u^2}^W \exp(-B_{u^2}^{W,2}) \right] - \frac{C_{-1}^W}{u^2} - C_0 \right\} \frac{du}{u} \\ + \int_1^{+\infty} \Phi \left(\text{Tr}_s \left[N_{u^2}^W \exp(-B_{u^2}^{W,2}) \right] \right. \\ \left. - \text{Tr}_s \left[N_{\mathbf{V}}^Y \exp(-\nabla^{H(Y,\eta|y),2}) \right] \right) \frac{du}{u} - \frac{1}{2} C_{-1}^W.$$

$\delta)$ **Evaluation of I_1^3**

Theorem 6.11 — *The following identity holds*

$$(6.36) \quad I_1^3 = -\frac{1}{2} [T(\omega^W, g^\eta) - \Gamma'(1) \\ (C_0^W - \Phi \text{Tr}_s [N_{\mathbf{V}}^Y \exp(-\nabla^{H(Y,\eta|y),2})])] .$$

Proof. Equation (6.36) is a trivial consequence of (2.50) and (6.35). \square

The term I_2^0

The term I_2^0 is given by

$$(6.37) \quad I_2^0 = \int_1^{T_0} \Phi \operatorname{Tr}_s [N_{\mathbf{H}} \exp(-B_{A,T}^2)] \frac{dT}{T}.$$

$\alpha)$ $A \rightarrow +\infty$

By Theorem 6.6, as $A \rightarrow +\infty$

$$(6.38) \quad I_2^0 \rightarrow I_2^1 = \int_1^{T_0} \Phi \operatorname{Tr}_s \left[P_T N_{\mathbf{H}} P_T \exp \left(-\nabla_T^{H(X,\xi|x),2} \right) \right] \frac{dT}{T}.$$

$\beta)$ $T_0 \rightarrow +\infty$

By making $u \rightarrow +\infty$ in Theorem 6.5, and using Theorems 2.20 and 6.6, we get for $T \geq 1$

$$(6.39) \quad \left| \operatorname{Tr}_s \left[P_T N_{\mathbf{H}} P_T \exp \left(-\nabla_T^{H(X,\xi|x),2} \right) \right] - \frac{1}{2} \dim N_{Y/X} \operatorname{Tr}_s \left[\exp \left(-\nabla^{H(Y,\eta|y),2} \right) \right] \right| \leq \frac{C}{T^\delta}.$$

From (6.38), (6.39), we see that as $T_0 \rightarrow +\infty$,

$$(6.40) \quad I_2^1 - \frac{1}{2} \dim N_{Y/X} \Phi \operatorname{Tr}_s \left[\exp \left(-\nabla^{H(Y,\eta|y),2} \right) \right] \log(T_0) \\ \rightarrow I_2^2 = \int_1^{+\infty} \Phi \left(\operatorname{Tr}_s \left[P_T N_{\mathbf{H}} P_T \exp \left(-\nabla_T^{H(Y,\eta|y),2} \right) \right] - \frac{1}{2} \dim N_{Y/X} \operatorname{Tr}_s \left[\exp \left(-\nabla^{H(Y,\eta|y),2} \right) \right] \right) \frac{dT}{T}.$$

$\gamma)$ $\varepsilon \rightarrow 0$

The term I_2^2 remains constant and equal to I_2^3 .

 $\delta)$ Evaluation of I_2^3

Theorem 6.12 — *The following identity holds*

$$(6.41) \quad I_2^3 = \frac{1}{2} \widetilde{\operatorname{ch}} \left(H^{(Y,\eta|y)}, g^{H(X,\xi|x)}, g^{H(Y,\eta|y)} \right) \text{ in } P^S / P^{S,0}.$$

Proof. Let $\dim N_{Y/X}$ be the operator acting on $H(Y,\eta|Y)$ by multiplication by $\dim N_{Y_i/X}$ on $H(Y_i, \eta|Y_i)$ ($1 \leq i \leq d$). Set

$$(6.42) \quad g_T^{H(Y,\eta|y)'} = T^{\dim N_{Y/X}} g_T^{H(Y,\eta|y)}.$$

Then by Theorem 6.10, as $T \rightarrow +\infty$

$$(6.43) \quad g_T^{H(Y, \eta|_Y)'} = g^{H(Y, \eta|_Y)} + \mathcal{O}\left(\frac{1}{\sqrt{T}}\right).$$

By Hodge theory, the map $s \in K_1 \rightarrow P_T s \in K_T$ is the canonical isomorphism of K_1 with K_T , these two bundles being identified to $H(X, \xi|_X)$. In particular if $s \in K_1$, $1 < T < T'$,

$$(6.44) \quad P_{T'} P_T s = P_{T'} s.$$

Using (6.44), if $s, s' \in K_1$, we get

$$(6.45) \quad \frac{\partial}{\partial T} \langle P_T s, P_T s' \rangle_T = \left\langle \frac{\partial P_T}{\partial T} P_T s, P_T s' \right\rangle_T + \left\langle P_T s, \frac{\partial P_T}{\partial T} P_T s' \right\rangle_T - \frac{2}{T} \langle N_{\mathbf{H}} P_T s, P_T s' \rangle_T.$$

Since $P_T^2 = P_T$, then

$$(6.46) \quad \frac{\partial P_T}{\partial T} P_T + P_T \frac{\partial P_T}{\partial T} = \frac{\partial P_T}{\partial T}.$$

From (6.46), we see that $\frac{\partial P_T}{\partial T}$ maps K_T into its orthogonal K_T^\perp with respect to $\langle \cdot, \cdot \rangle_T$. Therefore (6.45) is equivalent to

$$(6.47) \quad \frac{\partial}{\partial T} \langle P_T s, P_T s' \rangle_T = -\frac{2}{T} \langle N_{\mathbf{H}} P_T s, P_T s' \rangle_T.$$

From (6.47), we deduce

$$(6.48) \quad g_T^{H(X, \xi|_X) - 1} \frac{\partial g_T^{H(X, \xi|_X)}}{\partial T} = -\frac{2}{T} P_T N_{\mathbf{H}} P_T.$$

By [13, Corollary 1.30], we know that for a given $T_0 \geq 1$,

$$(6.49) \quad I_2^1 = \frac{1}{2} \tilde{\text{ch}} \left(H(X, \xi|_X), g^{H(X, \xi|_X)}, g_{T_0}^{H(X, \xi|_X)} \right).$$

Equivalently

$$(6.50) \quad I_2^1 = \frac{1}{2} \tilde{\text{ch}} \left(H(Y, \eta|_Y), g^{H(X, \xi|_X)}, g_{T_0}^{H(Y, \eta|_Y)} \right).$$

By (6.43) and by [13, Corollary 1.30], as $T_0 \rightarrow +\infty$,

$$(6.51) \quad \tilde{\text{ch}} \left(H(Y, \eta|_Y), g_{T_0}^{H(Y, \eta|_Y)}, g^{H(Y, \eta|_Y)} \right) = -\dim N_{Y/X} \Phi \text{Tr}_s \left[\exp \left(-\nabla^{H(Y, \eta|_Y), 2} \right) \right] \log(T_0) + \mathcal{O}\left(\frac{1}{\sqrt{T}}\right).$$

From (6.50), (6.51), we see that

$$(6.52) \quad I_2^1 - \frac{1}{2} \dim N_{Y/X} \Phi \operatorname{Tr}_s \left[\exp \left(-\nabla^{H(Y, \eta|_Y), 2} \right) \right] \log(T_0) \\ = \frac{1}{2} \tilde{\operatorname{ch}} \left(H(Y, \eta|_Y), g^{H(X, \xi|_X)}, g^{H(Y, \eta|_Y)} \right) + \mathcal{O}\left(\frac{1}{\sqrt{T}}\right).$$

From (6.40), (6.52), we get (6.41). \square

The term I_3^0

We have the identity

$$(6.53) \quad I_3^0 = - \int_{\varepsilon}^A \Phi \operatorname{Tr}_s \left[\bar{N}_{u^2}^V \exp(-\bar{B}_{u^2}^{V,2}) \right] \frac{du}{u}.$$

$\alpha)$ $A \rightarrow +\infty$

By Theorem 6.6, as $A \rightarrow +\infty$,

$$(6.54) \quad I_3^0 + \Phi \operatorname{Tr}_s \left[(N_{\mathbf{V}}^X - N_{\mathbf{H}}) \exp \left(-\nabla^{H(X, \xi|_X), 2} \right) \right] \log(A) \\ \rightarrow I_3^1 = - \int_{\varepsilon}^1 \Phi \operatorname{Tr}_s \left[\bar{N}_{u^2}^V \exp(-\bar{B}_{u^2}^{V,2}) \right] \frac{du}{u} \\ + \int_1^{+\infty} \Phi \left(\operatorname{Tr}_s \left[\bar{N}_{u^2}^V \exp(-\bar{B}_{u^2}^{V,2}) \right] \right. \\ \left. - \operatorname{Tr}_s \left[(N_{\mathbf{V}}^X - N_{\mathbf{H}}) \exp \left(-\nabla^{H(X, \xi|_X), 2} \right) \right] \right) \frac{du}{u}.$$

$\beta)$ $T_0 \rightarrow +\infty$

The term I_3^1 remains constant and equal to I_3^2 .

$\gamma)$ $\varepsilon \rightarrow 0$

By Theorem 6.4, as $\varepsilon \rightarrow 0$,

$$(6.55) \quad I_3^2 + \frac{1}{2} D_{-1}^V \frac{1}{\varepsilon^2} - D_0^V \log(\varepsilon) \rightarrow \\ I_3^3 = - \int_0^1 \left\{ \Phi \operatorname{Tr}_s \left[\bar{N}_{u^2}^V \exp(-\bar{B}_{u^2}^{V,2}) \right] - \frac{D_{-1}^V}{u^2} - D_0^V \right\} \frac{du}{u} \\ - \int_1^{+\infty} \Phi \left(\operatorname{Tr}_s \left[\bar{N}_{u^2}^V \exp(-\bar{B}_{u^2}^{V,2}) \right] \right. \\ \left. - \operatorname{Tr}_s \left[(N_{\mathbf{V}}^X - N_{\mathbf{H}}) \exp \left(-\nabla^{H(X, \xi|_X), 2} \right) \right] \right) \frac{du}{u} + \frac{1}{2} D_{-1}^V.$$

δ) **Evaluation of I_3^3**

Theorem 6.13 — *The following identity holds*

$$(6.56) \quad I_3^3 = \frac{1}{2} \left\{ T(\omega^V, g^\xi) - \Gamma'(1)(D_0^V - \Phi \operatorname{Tr}_s \left[(N_{\mathbf{V}}^X - N_{\mathbf{H}}) \exp \left(-\nabla^{H(X, \xi|_X), 2} \right) \right] \right\}.$$

Proof. This follows from the obvious analogue of (2.50) and from (6.55). \square

The term I_4^0

We have the identity

$$(6.57) \quad I_4^0 = - \int_1^{T_0} \Phi \operatorname{Tr}_s \left[N_{\mathbf{H}} \exp(-B_{\varepsilon, T}^2) \right] \frac{dT}{T}.$$

α) $A \rightarrow +\infty$

The term I_4^0 remains constant and equal to I_4^1 .

β) $T_0 \rightarrow +\infty$

By Theorem 6.5, we find that as $T_0 \rightarrow +\infty$

$$(6.58) \quad \begin{aligned} I_4^1 + \frac{1}{2} \dim N_{Y/X} \Phi \operatorname{Tr}_s \left[\exp(-B_{\varepsilon^2}^{W, 2}) \right] \log(T_0) \\ \rightarrow I_4^2 = - \int_1^{+\infty} \Phi \left(\operatorname{Tr}_s \left[N_{\mathbf{H}} \exp(-B_{\varepsilon, T}^2) \right] - \frac{1}{2} \dim N_{Y/X} \operatorname{Tr}_s \left[\exp(-B_{\varepsilon^2}^{W, 2}) \right] \right) \frac{dT}{T}. \end{aligned}$$

γ) $\varepsilon \rightarrow 0$

We proceed as in [19, p. 65]. Set

$$(6.59) \quad \begin{aligned} J_1^0 &= - \int_{\varepsilon}^1 \Phi \operatorname{Tr}_s \left[N_{\mathbf{H}} \exp(-A_{\varepsilon, T}^2) \right] \frac{dT}{T}, \\ J_2^0 &= - \int_{\varepsilon}^1 \Phi \operatorname{Tr}_s \left[N_{\mathbf{H}} \exp(-A_{\varepsilon, T/\varepsilon}^2) \right] \frac{dT}{T} \\ J_3^0 &= - \int_1^{+\infty} \Phi \left(\operatorname{Tr}_s \left[N_{\mathbf{H}} \exp(-A_{\varepsilon, T/\varepsilon}^2) \right] - \frac{1}{2} \dim N_{Y/X} \Phi \operatorname{Tr}_s \left[\exp(-B_{\varepsilon^2}^{W, 2}) \right] \right) \frac{dT}{T}. \end{aligned}$$

Clearly

$$(6.60) \quad I_4^2 = J_1^0 + J_2^0 + J_3^0 - \dim N_{Y/X} \Phi \operatorname{Tr}_s \left[\exp(-B_{\varepsilon^2}^{W,2}) \right] \log(\varepsilon).$$

1) *The term J_1^0 .*

We have the identity

$$(6.61) \quad J_1^0 = - \int_{\varepsilon}^1 \Phi \left(\operatorname{Tr}_s \left[N_{\mathbf{H}} \exp(-A_{\varepsilon,T}^2) \right] - \operatorname{Tr}_s \left[N_{\mathbf{H}} \exp(-A_{\varepsilon,0}^2) \right] \right) \frac{dT}{T} \\ + \Phi \operatorname{Tr}_s \left[N_{\mathbf{H}} \exp(-A_{\varepsilon,0}^2) \right] \log(\varepsilon).$$

By Theorem 6.7, we find that as $\varepsilon \rightarrow 0$

$$(6.62) \quad J_1^0 - \int_X \operatorname{Td}(TX, g^{TX}) \operatorname{ch}'(\xi, g^{\xi}) \log(\varepsilon) \\ \rightarrow J_1^1 = - \int_0^1 \int_X \operatorname{Td}(TX, g^{TX}) \\ \Phi \operatorname{Tr}_s \left[N_{\mathbf{H}} (\exp(-C_{T^2}^2) - \exp(-C_0^2)) \right] \frac{dT}{T}.$$

2) *The term J_2^0 .*

As in [19, p. 66], we write J_2^0 in the form

$$(6.63) \quad J_2^0 = - \int_{\varepsilon}^1 \left\{ \Phi \operatorname{Tr}_s \left[N_{\mathbf{H}} \exp(-A_{\varepsilon,T/\varepsilon}^2) \right] \right. \\ \left. - \int_X \operatorname{Td}(TX, g^{TX}) \Phi \operatorname{Tr}_s \left[N_{\mathbf{H}} \exp(-C_{(T/\varepsilon)^2}^2) \right] \right\} \frac{dT}{T} \\ - \int_1^{1/\varepsilon} \left\{ \int_X \operatorname{Td}(TX, g^{TX}) \Phi \operatorname{Tr}_s \left[N_{\mathbf{H}} \exp(-C_{T^2}^2) \right] \right\} \frac{dT}{T}.$$

By Theorem 6.7, there is $C > 0$, $\gamma \in]0, 1]$ such that for $0 < \varepsilon \leq T \leq 1$

$$(6.64) \quad \left| \Phi \operatorname{Tr}_s \left[N_{\mathbf{H}} \exp(-A_{\varepsilon,T/\varepsilon}^2) \right] - \int_X \operatorname{Td}(TX, g^{TX}) \right. \\ \left. \Phi \operatorname{Tr}_s \left[N_{\mathbf{H}} \exp(-C_{(T/\varepsilon)^2}^2) \right] \right| \leq C(\varepsilon + T)^{\gamma} \leq C(2T)^{\gamma}.$$

We now combine Theorems 3.6, 5.8, 6.8 and (6.64). We thus find that as $\varepsilon \rightarrow 0$

$$(6.65) \quad J_2^0 + \int_Y \text{Td}(TX, g^{TX})(\text{Td}^{-1})'(N_{Y/X}, g^{N_{Y/X}}) \text{ch}(\eta, g^\eta) \log(\varepsilon) \\ \longrightarrow J_2^1 = - \int_Y \int_0^1 \left\{ \Phi \text{Tr}_s [N_{\mathbf{H}} \exp(-\mathfrak{B}_{T^2}^2)] + \text{Td}(TX, g^{TX})(\text{Td}^{-1})' \right. \\ \left. (N_{Y/X}, g^{N_{Y/X}}) \right\} \frac{dT}{T} \text{ch}(\eta, g^\eta) \\ - \int_1^{+\infty} \left\{ \int_X \text{Td}(TX, g^{TX}) \Phi \text{Tr}_s [N_{\mathbf{H}} \exp(-C_{T^2}^2)] \right. \\ \left. + \int_Y \text{Td}(TX, g^{TX})(\text{Td}^{-1})'(N_{Y/X}, g^{N_{Y/X}}) \text{ch}(\eta, g^\eta) \right\} \frac{dT}{T}.$$

3) *The term J_3^0 .*

Using Theorems 2.17, 6.8 and 6.9, we find that as $\varepsilon \rightarrow 0$

$$(6.66) \quad J_3^0 \rightarrow J_3^1 = - \int_1^{+\infty} \left\{ \int_Y (\Phi \text{Tr}_s [N_{\mathbf{H}} \exp(-\mathfrak{B}_{T^2}^2)] \right. \\ \left. - \frac{1}{2} \dim N_{Y/X} \text{Td}(TY, g^{TY})) \text{ch}(\eta, g^\eta) \right\} \frac{dT}{T}.$$

4) *The asymptotics of I_4^2 .*

By Theorem 2.17 and by (6.60), (6.62), (6.65), (6.66), we find that as $\varepsilon \rightarrow 0$,

$$(6.67) \quad I_4^2 + \left\{ \dim N_{Y/X} \int_Y \text{Td}(TY, g^{TY}) \text{ch}(\eta, g^\eta) - \int_X \text{Td}(TX, g^{TX}) \text{ch}'(\xi, g^\xi) \right. \\ \left. + \int_Y \text{Td}(TX, g^{TX})(\text{Td}^{-1})'(N_{Y/X}, g^{N_{Y/X}}) \text{ch}(\eta, g^\eta) \right\} \log(\varepsilon) \longrightarrow I_4^3 = \\ - \int_0^1 \left\{ \int_X \text{Td}(TX, g^{TX}) \Phi \text{Tr}_s [N_{\mathbf{H}}(\exp(-C_{T^2}^2) - \exp(-C_0^2))] \right\} \frac{dT}{T} \\ - \int_1^{+\infty} \left\{ \int_X \text{Td}(TX, g^{TX}) \Phi \text{Tr}_s [N_{\mathbf{H}}(\exp(-C_{T^2}^2)] + \int_Y \text{Td}(TX, g^{TX}) \right. \\ \left. (\text{Td}^{-1})'(N_{Y/X}, g^{N_{Y/X}}) \text{ch}(\eta, g^\eta) \right\} \frac{dT}{T} \\ - \int_Y \int_0^1 \left\{ \Phi \text{Tr}_s [N_{\mathbf{H}} \exp(-\mathfrak{B}_{T^2}^2)] + \text{Td}(TX, g^{TX}) \right. \\ \left. (\text{Td}^{-1})'(N_{Y/X}, g^{N_{Y/X}}) \right\} \frac{dT}{T} \text{ch}(\eta, g^\eta) \\ - \int_Y \int_1^{+\infty} \left\{ \Phi \text{Tr}_s [N_{\mathbf{H}} \exp(-\mathfrak{B}_{T^2}^2)] \right. \\ \left. - \frac{1}{2} \dim N_{Y/X} \text{Td}(TY, g^{TY}) \right\} \frac{dT}{T} \text{ch}(\eta, g^\eta).$$

δ) **Evaluation of I_4^3**

Theorem 6.14 — *The following identity holds*

$$(6.68) \quad I_4^3 = -\frac{1}{2} \left\{ \int_X \text{Td}(TX, g^{TX}) T(\xi, g^\xi) \right. \\ + \int_Y \mathbf{B}(TY, TX|_W, g^{TX|_W}) \text{ch}(\eta, g^\eta) \\ + \Gamma'(1) \left(\int_X \text{Td}(TX, g^{TX}) \text{ch}'(\xi, g^\xi) \right. \\ \left. \left. - \frac{1}{2} \dim N_{Y/X} \int_Y \text{Td}(TY, g^{TY}) \text{ch}(\eta, g^\eta) \right) \right\}.$$

Proof. Using formulas (3.34) for $T(\xi, g^\xi)$, (5.25) for $\mathbf{B}(TY, TX|_W, g^{TX|_W})$ and (6.67) for I_4^3 , we get (6.68). \square

6.5 The divergences of the left-hand side of (4.26)

Now we will summarize the divergences of $\sum_{k=1}^4 I_k^0$ as $A \rightarrow +\infty$, $T_0 \rightarrow +\infty$, $\varepsilon \rightarrow 0$. As should be the case, the diverging terms lie in $P^{S,0}$.

α) $A \rightarrow +\infty$

By (6.28), (6.54), which concern I_1^0, I_3^0 , the diverging term

$$(6.69) \quad \left\{ -\Phi \text{Tr}_s \left[(N_{\mathbf{V}}^X - N_{\mathbf{H}}) \exp(-\nabla_{T_0}^{H(X, \xi|_X), 2}) \right] \right. \\ \left. + \Phi \text{Tr}_s \left[(N_{\mathbf{V}}^X - N_{\mathbf{H}}) \exp(-\nabla^{H(X, \xi|_X), 2}) \right] \right\} \log(A)$$

appears. By [20], [13, Theorem 1.27], this term lies in $P^{S,0}$.

β) $T_0 \rightarrow +\infty$

By formulas (6.40), (6.58), which concern I_2^1, I_4^1 , we get the diverging terms

$$(6.70) \quad \left\{ -\frac{1}{2} \dim N_{Y/X} \Phi \text{Tr}_s \left[\exp(-\nabla^{H(Y, \eta|_Y), 2}) \right] \right. \\ \left. + \frac{1}{2} \dim N_{Y/X} \Phi \text{Tr}_s \left[\exp(-B_{\varepsilon^2}^{W, 2}) \right] \right\} \log(T_0).$$

By Theorems 2.16, 2.20, 2.23, this term lies in $P^{S,0}$.

$\gamma) \quad \varepsilon \rightarrow 0$

We get a first sort of terms in formulas (6.35), (6.55) which concern I_1^2, I_3^2 ,

$$(6.71) \quad \frac{1}{2} \{-C_{-1}^W + D_{-1}^V\} \frac{1}{\varepsilon^2}.$$

Since ω^V is closed, it follows from (3.35), (6.14), (6.16) that $-C_{-1}^W + D_{-1}^V$ lies in $P^{S,0}$.

By equations (6.35), (6.55), (6.67) which concern I_1^2, I_3^2, I_4^2 , we also get the diverging terms

$$(6.72) \quad \left\{ C_0^W - D_0^V + \dim N_{Y/X} \int_Y \text{Td}(TY, g^{TY}) \text{ch}(\eta, g^\eta) \right. \\ \left. - \int_X \text{Td}(TX, g^{TX}) \text{ch}'(\xi, g^\xi) + \int_Y \text{Td}(TX, g^{TX}) \right. \\ \left. (\text{Td}^{-1})'(N_{Y/X}, g^{N_{Y/X}}) \text{ch}(\eta, g^\eta) \right\} \log(\varepsilon).$$

Using (6.14), (6.16) and the arguments of [19, p. 70, 71], one verifies easily that (6.72) lies in $P^{S,0}$.

If S is compact and Kähler, $P^{S,0}$ is closed under uniform convergence. In this case, it is not difficult to see that since $\sum_{k=1}^4 I_k^0 \in P^{S,0}$, then $\sum_1^4 I_k^3 \in P^{S,0}$. The reader who is only interested in this case can skip Sections 6.7 and 6.8.

In the case of a general S , $P^{S,0}$ is no longer closed. Also recall that our final purpose is to obtain a local equality in $P^S/P^{S,0}$. This is why in Sections 6.6 and 6.7, we discuss in detail the right-hand side of (4.26).

Finally observe that since in general, exact forms are closed under uniform convergence, part of the discussion of Sections 6.7 and 6.8 can be eliminated, if we just want to show that $\sum_{k=1}^4 I_k^3 \in P^{S,0}$.

6.6 The right-hand side of (4.26): five intermediate results

Now we will state intermediate results, which are needed in the study of the asymptotics of $\Phi(\bar{\partial}\mu^0 + \partial\nu^0) - \frac{\bar{\partial}\partial}{i\pi}\Phi\lambda^0$, which appears in the right-hand side of (4.26).

If $h_{u,T}$ is a function of $(u, T) \in \mathbf{R}_+^* \times \mathbf{R}_+^*$, we denote by $h_{0,T}$ the limit (when it exists) of $h_{u,T}$ as $u \rightarrow 0$. Also $h_{0,\infty}$ denote the limit (when it exists) of $h_{0,T}$ as $T \rightarrow +\infty$. Similar conventions apply to functions h_u^* .

Let da be the canonical generator of \mathbf{C}^* . Then $dad\bar{a}$ span $\mathbf{R}^{2*} \otimes_{\mathbf{R}} \mathbf{C}$. If $\sigma \in \Lambda(T_{\mathbf{R}}^*S) \hat{\otimes}_{\mathbf{R}} \Lambda(\mathbf{R}^{2*})$ we write σ in the form

$$(6.73) \quad \sigma = s_0 + da\sigma^{da} + d\bar{a}\sigma^{d\bar{a}} + dad\bar{a}\sigma^{dad\bar{a}}, \sigma_0, \sigma^{da}, \sigma^{d\bar{a}}, \sigma^{dad\bar{a}} \in \Lambda(T_{\mathbf{R}}^*S).$$

Put

$$\begin{aligned}
(6.74) \quad \kappa_{u,T} &= \frac{\partial}{\partial b} \operatorname{Tr}_s \left[N_{\mathbf{H}} \exp(-A^2_{\sqrt{u},\sqrt{T}} - bN_u^V) \right]_{b=0}, \\
\kappa_u^* &= -\frac{1}{2} \dim N_{Y/X} \operatorname{Tr}_s \left[(N_u^W + \frac{1}{2} \dim N_{Y/X}) \exp(-B_u^{W,2}) \right], \\
\theta_{u,T} &= \frac{\partial}{\partial b} \operatorname{Tr}_s \left[\exp(-A^2_{\sqrt{u},\sqrt{T}} - 2dau \frac{\partial}{\partial u} A''_{\sqrt{u},\sqrt{T}} - 2d\bar{a}u \frac{\partial}{\partial u} A'_{\sqrt{u},\sqrt{T}} \right. \\
&\quad \left. + dad\bar{a} \frac{\partial}{\partial u} (uN_u^V) - bN_{\mathbf{H}} \right]_{b=0}^{dad\bar{a}}, \\
\theta_u^* &= -\frac{1}{2} \dim N_{Y/X} \operatorname{Tr}_s \left[\exp(-B_u^{W,2} - da2u \frac{\partial}{\partial u} B_u^{W''} - d\bar{a}2u \frac{\partial}{\partial u} B_u^{W'}) \right. \\
&\quad \left. + dad\bar{a} \left(\frac{\partial}{\partial u} (uN_u^W) + \frac{1}{2} \dim N_{Y/X} \right) \right]^{dad\bar{a}}, \\
\eta_{u,T} &= \frac{1}{2} \frac{\partial^2}{\partial c^2} \operatorname{Tr}_s \left[\exp(-A^2_{\sqrt{u},\sqrt{T}} + cN_u^V) \right]_{c=0}, \\
\eta_u^* &= \frac{1}{2} \frac{\partial^2}{\partial c^2} \operatorname{Tr}_s \left[\exp(-B_u^{W,2} + c(N_u^W + \frac{1}{2} \dim N_{Y/X})) \right]_{c=0}, \\
\lambda'_{u,T} &= \frac{\partial}{\partial b} \operatorname{Tr}_s \left[\exp(-A^2_{\sqrt{u},\sqrt{T}} + 2d\bar{a}u \frac{\partial}{\partial u} B_u^{V'} - b\sqrt{T}v) \right]_{b=0}^{d\bar{a}}, \\
\lambda''_{u,T} &= \frac{\partial}{\partial b} \operatorname{Tr}_s \left[\exp(-A^2_{\sqrt{u},\sqrt{T}} + 2dau \frac{\partial}{\partial u} B_u^{V''} - b\sqrt{T}v^*) \right]^{da}, \\
\lambda_u^* &= 0, \\
\lambda_u^{**} &= 0, \\
\pi'_{u,T} &= \frac{\partial}{\partial b} \operatorname{Tr}_s \left[N_{\mathbf{H}} \exp(-A^2_{\sqrt{u},\sqrt{T}} - 2d\bar{a}u \frac{\partial}{\partial u} A'_{\sqrt{u},\sqrt{T}}) \right]^{d\bar{a}}, \\
\pi''_{u,T} &= \frac{\partial}{\partial b} \operatorname{Tr}_s \left[N_{\mathbf{H}} \exp(-A^2_{\sqrt{u},\sqrt{T}} - 2dau \frac{\partial}{\partial u} A''_{\sqrt{u},\sqrt{T}}) \right]^{da}, \\
\pi_u^* &= \frac{1}{2} \dim N_{Y/X} \operatorname{Tr}_s \left[\exp(-B_u^{W,2} - 2d\bar{a}u \frac{\partial}{\partial u} B_u^{W'}) \right]_{b=0}^{d\bar{a}}, \\
\pi_u^{**} &= \frac{1}{2} \dim N_{Y/X} \operatorname{Tr}_s \left[\exp(-B_u^{W,2} - 2dau \frac{\partial}{\partial u} B_u^{W''}) \right]_{b=0}^{da}.
\end{aligned}$$

Observe that by (2.33),

$$\begin{aligned}
(6.75) \quad \pi_u^* &= \partial \kappa_u^*, \\
\pi_u^{**} &= -\bar{\partial} \kappa_u^*.
\end{aligned}$$

Computations on the model of [14, Theorem 2.16], and Theorem 3.6 show that

(6.76)

$$\begin{aligned}\Phi\theta_{0,T} &= - \int_X (\dim X \operatorname{Td}(TX, g^{TX}) - \operatorname{Td}'(TX, g^{TX})) \Phi \operatorname{Tr}_s [N_{\mathbf{H}} \exp(-C_T^2)] , \\ \Phi\theta_{0,\infty} &= \int_Y (\dim X \operatorname{Td}(TX, g^{TX}) - \operatorname{Td}'(TX, g^{TX})) (\operatorname{Td}^{-1})' \\ &\quad (N_{Y/X}, g^{N_{Y/X}}) \operatorname{ch}(\eta, g^\eta) , \\ \Phi\theta_0^* &= - \int_Y \frac{1}{2} \dim N_{Y/X} \left((\dim TY + \frac{1}{2} \dim N_{Y/X}) \operatorname{Td}(TY, g^{TY}) \right. \\ &\quad \left. - \operatorname{Td}'(TY, g^{TY}) \right) \operatorname{ch}(\eta, g^\eta) , \\ \lambda'_{0,T} &= 0, \quad \lambda''_{0,T} = 0, \\ \pi'_{0,T} &= 0, \quad \pi''_{0,T} = 0, \pi_0'^* = 0, \quad \pi_0''^* = 0.\end{aligned}$$

Again, we use the notation of Chapter 5 with respect to the exact sequence of holomorphic Hermitian vector bundles (6.1) on W .

Put

$$\begin{aligned}\theta_T &= \left(\frac{1}{2\pi i} \right)^{\dim Y} \int_Y \Theta_T \operatorname{Tr} [\exp(-\nabla^{\eta,2})] , \\ \lambda_T &= \left(\frac{1}{2\pi i} \right)^{\dim Y} \int_Y \Lambda_T \operatorname{Tr} [\exp(-\nabla^{\eta,2})] , \\ \lambda'_T &= - \left(\frac{1}{2\pi i} \right)^{\dim Y} \int_Y \Lambda_T \operatorname{Tr} [\exp(-\nabla^{\eta,2})] , \\ \lambda''_T &= \left(\frac{1}{2\pi i} \right)^{\dim Y} \int_Y \Lambda_T \operatorname{Tr} [\exp(-\nabla^{\eta,2})] , \\ \pi'_T &= \left(\frac{1}{2\pi i} \right)^{\dim Y} \int_Y \Pi'_T \operatorname{Tr} [\exp(-\nabla^{\eta,2})] , \\ \pi''_T &= \left(\frac{1}{2\pi i} \right)^{\dim Y} \int_Y \Pi''_T \operatorname{Tr} [\exp(-\nabla^{\eta,2})] .\end{aligned}\tag{6.77}$$

Observe that by Theorem 5.29 and by (6.76), (6.77),

$$\begin{aligned}\Phi\theta_{0,\infty} &= \Phi\theta_0 , \\ \Phi\theta_0^* &= \Phi\theta_\infty .\end{aligned}\tag{6.78}$$

Similar trivial equalities hold for $\lambda', \lambda'', \pi', \pi''$.

Now we state five intermediate results contained in Theorems 6.15-6.19. They will be used to study the right-hand side of (4.26). The proofs of Theorems 6.15-6.19 are deferred to Chapters 7-13.

Theorem 6.15 — For any compact set $K \subset S$, for any $u_0 > 0$, there exist $C > 0$, $\delta \in]0, \frac{1}{2}]$ such that for $u \geq u_0$, $T \geq 1$,

$$(6.79) \quad \left| \frac{\partial}{\partial b} \text{Tr}_s \left[N_{\mathbf{H}} \exp(-B_{u,T}^2 - bu \frac{\partial}{\partial u} B_{u^2}^{V'/'}) \right]_{b=0} - \frac{1}{2} \dim N_{Y/X} \frac{\partial}{\partial b} \text{Tr}_s \left[\exp(-B_{u^2}^{W,2} - bu \frac{\partial}{\partial u} B_{u^2}^{W'/'}) \right]_{b=0} \right| \leq \frac{C}{T^\delta},$$

$$\left| \frac{\partial}{\partial b} \text{Tr}_s [N_{\mathbf{H}} \exp(-B_{u,T}^2 - bN_{u^2}^V)] + \frac{1}{2} \dim N_{Y/X} \text{Tr}_s \left[(N_{u^2}^W + \frac{1}{2} \dim N_{Y/X}) \exp(-B_{u^2}^{W,2}) \right] \right| \leq \frac{C}{T^\delta} \quad \text{on } K.$$

Theorem 6.16 — For any compact set $K \subset S$, for any $u_0 > 0$, there exists $C > 0$ such that for $u \geq u_0$, $T \geq 1$,

$$(6.80) \quad \left| \frac{\partial}{\partial b} \text{Tr}_s \left[N_{\mathbf{H}} \exp(-B_{u,T}^2 - bu \frac{\partial}{\partial u} B_{u^2}^{V'/'}) \right]_{b=0} - \frac{\partial}{\partial b} \text{Tr}_s \left[P_T N_{\mathbf{H}} P_T \exp(-\nabla_T^{H(X,\xi|x),2} - / + b \nabla_T^{H(X,\xi|x)'} P_T N_{\mathbf{V}}^X P_T) \right]_{b=0} \right| \leq \frac{C}{u},$$

$$\left| \frac{\partial}{\partial b} \text{Tr}_s [N_{\mathbf{H}} \exp(-B_{u,T}^2 - bN_{u^2}^V)]_{b=0} - \frac{\partial}{\partial b} \text{Tr}_s \left[P_T N_{\mathbf{H}} P_T \exp(-\nabla_T^{H(X,\xi|x),2} - bP_T N_{\mathbf{V}}^X P_T) \right]_{b=0} \right| \leq \frac{C}{u} \quad \text{on } K.$$

Theorem 6.17 — For any compact set $K \subset S$, for any $T_0 \geq 0$, there exist $C > 0$ such that if $h_{u,T}$ is one of the functions $\theta_{u,T}$, $\pi'_{u,T}$, $\pi''_{u,T}$, for $0 < u \leq 1$, $0 \leq T \leq T_0$,

$$(6.81) \quad |h_{u,T} - h_{0,T}| \leq Cu \quad \text{on } K.$$

For any compact set $K \subset S$, there exist $C > 0$, $\gamma \in]0, 1]$ such that if $h_{u,T}$ is one of the functions $\theta_{u,T}$, $\pi'_{u,T}$, $\pi''_{u,T}$, for $0 < u \leq 1$, $0 \leq T \leq 1/u$,

$$(6.82) \quad |h_{u,T} - h_{0,T}| \leq C(u(1+T))^\gamma \quad \text{on } K.$$

Theorem 6.18 — For any compact set $K \subset S$, there exist $C > 0$, $\beta \in]0, 1]$, $\rho \in]0, 1]$ such that if $h_{u,T}$ is one of the functions $\theta_{u,T}$, $\lambda'_{u,T}$, $\lambda''_{u,T}$, $\pi'_{u,T}$, $\pi''_{u,T}$, for $u \in]0, 1]$, $T \in [u, 1]$,

$$(6.83) \quad |h_{u,T/u} - h_T| \leq \frac{Cu^\alpha}{T^\beta} \quad \text{on } K,$$

and for $u \in]0, 1]$, $T \geq 1$,

$$(6.84) \quad |h_{u,T/u} - h_T| \leq Cu^\rho \quad \text{on } K.$$

Theorem 6.19 — For any compact set $K \subset S$ (resp. and given $u_0 \in]0, 1]$), there exist $C > 0$, $\delta \in]0, 1]$ such that if $h_{u,T}$ is one of the functions $\theta_{u,T}$, $\lambda'_{u,T}$, $\lambda''_{u,T}$, $\pi'_{u,T}$, $\pi''_{u,T}$ (resp. $\eta_{u,T}$), for $u \in]0, 1]$, $T \geq 1$ (resp. for $u \in [u_0, 1]$, $T \geq 1$),

$$(6.85) \quad |h_{u,T/u} - h_u^*| \leq \frac{C}{T^\delta} \text{ on } K.$$

Theorems 6.15 and 6.16 will be proved in Chapter 9, Theorem 6.17 in Chapter 11, the first half of Theorem 6.18 in Chapter 12, the second half of Theorem 6.18 and Theorem 6.19 in Chapter 13.

6.7 The asymptotics of the right-hand side of (4.26)

$\alpha)$ $A \rightarrow +\infty$

By Theorem 6.16, we see that as $A \rightarrow +\infty$,

$$(6.86) \quad \begin{aligned} \mu^0 - 2 \int_1^{T_0} \frac{\partial}{\partial b} \text{Tr}_s \left[P_T N_{\mathbf{H}} P_T \exp(-\nabla_T^{H(X,\xi|X),2} \right. \\ \left. - b \nabla_T^{H(X,\xi|X)'} P_T N_{\mathbf{V}}^X P_T \right]_{b=0} \frac{dT}{T} \log(A) \rightarrow \\ \mu^1 = 2 \int_{\substack{\varepsilon \leq u \leq 1 \\ 1 \leq T \leq T_0}} \frac{\partial}{\partial b} \text{Tr}_s \left[N_{\mathbf{H}} \exp(-B_{u,T}^2 - bu \frac{\partial}{\partial u} B_{u^2}^{V'}) \right]_{b=0} \frac{dT du}{Tu} \\ + 2 \int_{\substack{1 \leq u \leq +\infty \\ 1 \leq T \leq T_0}} \left(\frac{\partial}{\partial b} \text{Tr}_s \left[N_{\mathbf{H}} \exp(-B_{u,T}^2 - bu \frac{\partial}{\partial u} B_{u^2}^{V'}) \right]_{b=0} \right. \\ \left. - \frac{\partial}{\partial b} \text{Tr}_s \left[P_T N_{\mathbf{H}} P_T \exp(-\nabla_T^{H(X,\xi|X),2} \right. \right. \\ \left. \left. - b \nabla_T^{H(X,\xi|X)'} P_T N_{\mathbf{V}}^X P_T \right]_{b=0} \right) \frac{dT du}{Tu}. \end{aligned}$$

A similar result holds for ν^0 , replacing $\nabla_T^{H(X,\xi|X)'} P_T N_{\mathbf{V}}^X P_T$ by $-\nabla_T^{H(X,\xi|X)''} P_T N_{\mathbf{V}}^X P_T$.

Finally by Theorem 6.16,

$$(6.87) \quad \begin{aligned} \lambda^0 - \int_1^{T_0} \frac{\partial}{\partial b} \text{Tr}_s \left[P_T N_{\mathbf{H}} P_T \exp(-\nabla_T^{H(X,\xi|X),2} \right. \\ \left. - b P_T N_{\mathbf{V}}^X P_T \right]_{b=0} \frac{dT}{T} \\ \log(A) \rightarrow \lambda^1 = \int_{\substack{\varepsilon \leq u \leq 1 \\ 1 \leq T \leq T_0}} \frac{\partial}{\partial b} \text{Tr}_s \left[N_{\mathbf{H}} \exp(-B_{u,T}^2 - b N_{u^2}^V) \right]_{b=0} \frac{dT du}{Tu} \\ + \int_{\substack{1 \leq u \leq +\infty \\ 1 \leq T \leq T_0}} \left(\frac{\partial}{\partial b} \text{Tr}_s \left[N_{\mathbf{H}} \exp(-B_{u,T}^2 - b N_{u^2}^V) \right]_{b=0} \right. \\ \left. - \frac{\partial}{\partial b} \text{Tr}_s \left[P_T N_{\mathbf{H}} P_T \exp(-\nabla_T^{H(X,\xi|X),2} - b P_T N_{\mathbf{V}}^X P_T) \right] \right) \frac{dT du}{Tu}. \end{aligned}$$

From (6.86), (6.87), we see that as $A \rightarrow +\infty$,

$$\begin{aligned}
 (6.88) \quad & \Phi(\bar{\partial}\mu^0 + \partial\nu^0) - \frac{\bar{\partial}\partial}{i\pi}\Phi\lambda^0 - \left[\Phi 2\bar{\partial} \int_1^{T_0} \frac{\partial}{\partial b} \text{Tr}_s \left[P_T N_{\mathbf{H}} P_T \exp(-\nabla_T^{H(X,\xi|x),2}) \right. \right. \\
 & \quad \left. \left. - b \nabla_T^{H(X,\xi|x)'} P_T N_{\mathbf{V}}^X P_T \right] \right]_{b=0} \frac{dT}{T} \\
 & + \Phi 2\partial \int_1^{T_0} \frac{\partial}{\partial b} \text{Tr}_s \left[P_T N_{\mathbf{H}} P_T \exp(-\nabla_T^{H(X,\xi|x),2}) \right. \\
 & \quad \left. + b \nabla_T^{H(X,\xi|x)''} P_T N_{\mathbf{V}}^X P_T \right] - \frac{\bar{\partial}\partial}{i\pi}\Phi \int_1^{T_0} \frac{\partial}{\partial b} \text{Tr}_s \left[P_T N_{\mathbf{H}} P_T \exp(-\nabla_T^{H(X,\xi|x),2}) \right. \\
 & \quad \left. - b P_T N_{\mathbf{V}}^X P_T \right] \Big]_{b=0} \frac{dT}{T} \Big] \log A \rightarrow \Phi(\bar{\partial}\mu^1 + \partial\nu^1) - \frac{\bar{\partial}\partial}{i\pi}\Phi\lambda^1.
 \end{aligned}$$

$\beta)$ $T_0 \rightarrow +\infty$

By proceeding as in [3, Theorem 9.23], one finds quite easily that as $u \rightarrow +\infty$,

$$(6.89) \quad \frac{\partial}{\partial b} \text{Tr}_s \left[\exp(-B_{u^2}^{W,2} - bu \frac{\partial}{\partial u} B_{u^2}^{W'}) \right]_{b=0} = \mathcal{O}\left(\frac{1}{u}\right).$$

By using (6.80), (6.89) and making $u \rightarrow +\infty$ in (6.79), we get for $T \geq 1$,

$$(6.90) \quad \left| \frac{\partial}{\partial b} \text{Tr}_s \left[P_T N_{\mathbf{H}} P_T \exp(-\nabla_T^{H(X,\xi|x),2}) - b \nabla_T^{H(X,\xi|x)'} P_T N_{\mathbf{V}}^X P_T \right] \right|_{b=0} \leq \frac{C}{T^\delta}.$$

By (6.79), (6.80), (6.89), (6.90), we find for $u \geq 1$, $T \geq 1$,

$$\begin{aligned}
 (6.91) \quad & \left| \frac{\partial}{\partial b} \text{Tr}_s \left[N_{\mathbf{H}} \exp(-B_{u,T}^2 - bu \frac{\partial}{\partial u} B_{u^2}^{V'}) \right] \right|_{b=0} \\
 & - \frac{\partial}{\partial b} \text{Tr}_s \left[P_T N_{\mathbf{H}} P_T \exp(-\nabla_T^{H(X,\xi|x),2}) - b \nabla_T^{H(X,\xi|x)'} P_T N_{\mathbf{V}}^X P_T \right] \Big]_{b=0} \\
 & - \frac{1}{2} \dim N_{Y/X} \frac{\partial}{\partial b} \text{Tr}_s \left[\exp(-B_{u^2}^{W,2} - bu \frac{\partial}{\partial u} B_{u^2}^{W'}) \right] \Big]_{b=0} \Big| \leq \frac{C}{(uT^\delta)^{1/2}}.
 \end{aligned}$$

Using Theorem 6.15 and the above inequality, we find that as $T_0 \rightarrow +\infty$,

$$\begin{aligned}
(6.92) \quad & \mu^1 - 2 \int_{\varepsilon}^{+\infty} \frac{1}{2} \dim N_{Y/X} \frac{\partial}{\partial b} \operatorname{Tr}_s \left[\exp(-B_{u^2}^{W,2} - bu \frac{\partial}{\partial u} B_{u^2}^{W'}) \right]_{b=0} \frac{du}{u} \log(T_0) \\
& \rightarrow \mu^2 = 2 \int_{\substack{\varepsilon \leq u \leq 1 \\ 1 \leq T < +\infty}} \left(\frac{\partial}{\partial b} \operatorname{Tr}_s \left[N_{\mathbf{H}} \exp(-B_{u,T}^2 - bu \frac{\partial}{\partial u} B_{u^2}^{V'}) \right]_{b=0} \right. \\
& \quad \left. - \frac{1}{2} \dim N_{Y/X} \frac{\partial}{\partial b} \operatorname{Tr}_s \left[\exp(-B_{u^2}^{W,2} - bu \frac{\partial}{\partial u} B_{u^2}^{W'}) \right]_{b=0} \right) \frac{dT du}{Tu} \\
& \quad + 2 \int_{\substack{1 \leq u < +\infty \\ 1 \leq T < +\infty}} \left(\frac{\partial}{\partial b} \operatorname{Tr}_s \left[N_{\mathbf{H}} \exp(-B_{u,T}^2 - bu \frac{\partial}{\partial u} B_{u^2}^{V'}) \right]_{b=0} \right. \\
& \quad \left. - \frac{\partial}{\partial b} \operatorname{Tr}_s \left[P_T N_{\mathbf{H}} P_T \exp(-\nabla_T^{H(X,\xi|x),2} - b \nabla_T^{H(X,\xi|x)'} P_T N_{\mathbf{V}}^X P_T) \right]_{b=0} \right. \\
& \quad \left. - \frac{1}{2} \dim N_{Y/X} \frac{\partial}{\partial b} \operatorname{Tr}_s \left[\exp(-B_{u^2}^{W,2} - bu \frac{\partial}{\partial u} B_{u^2}^{W'}) \right]_{b=0} \right) \frac{dT du}{Tu}.
\end{aligned}$$

A corresponding result holds for ν^1 . By Theorems 2.20, 6.15 and 6.16 and by proceeding as before, we see that as

$$\begin{aligned}
(6.93) \quad & \lambda^1 - \left[\int_{\varepsilon}^1 -\frac{1}{2} \dim N_{Y/X} \operatorname{Tr}_s \left[(N_{u^2}^W + \frac{1}{2} \dim N_{Y/X}) \exp(-B_{u^2}^{W,2}) \right] \frac{du}{u} \right. \\
& \quad \left. - \int_1^{+\infty} -\frac{1}{2} \dim N_{Y/X} \left(\operatorname{Tr}_s \left[(N_{u^2}^W + \frac{1}{2} \dim N_{Y/X}) \exp(-B_{u^2}^{W,2}) \right] \right. \right. \\
& \quad \left. \left. - \operatorname{Tr}_s \left[(N_{\mathbf{V}}^Y + \frac{1}{2} \dim N_{Y/X}) \exp(-\nabla^{H(Y,\eta|Y),2}) \right] \right) \frac{du}{u} \right] \log(T_0) \\
& \rightarrow \lambda^2 = \int_{\substack{\varepsilon \leq u \leq 1 \\ 1 \leq T < +\infty}} \left(\frac{\partial}{\partial b} \operatorname{Tr}_s \left[N_{\mathbf{H}} \exp(-B_{u,T}^2 - b N_{u^2}^V) \right]_{b=0} \right. \\
& \quad \left. + \frac{1}{2} \dim N_{Y/X} \operatorname{Tr}_s \left[(N_{u^2}^W + \frac{1}{2} \dim N_{Y/X}) \exp(-B_{u^2}^{W,2}) \right] \right) \frac{dT du}{Tu} \\
& \quad + \int_{\substack{1 \leq u < +\infty \\ 1 \leq T < +\infty}} \left(\left[\frac{\partial}{\partial b} \operatorname{Tr}_s \left[N_{\mathbf{H}} \exp(-B_{u,T}^2 - b N_{u^2}^V) \right]_{b=0} \right. \right. \\
& \quad \left. \left. - \frac{\partial}{\partial b} \operatorname{Tr}_s \left[P_T N_{\mathbf{H}} P_T \exp(-\nabla_T^{H(X,\xi|x),2} - b P_T N_{\mathbf{V}}^X P_T) \right]_{b=0} \right. \right. \\
& \quad \left. \left. + \frac{1}{2} \dim N_{Y/X} \left(\operatorname{Tr}_s \left[(N_{u^2}^W + \frac{1}{2} \dim N_{Y/X}) \exp(-B_{u^2}^{W,2}) \right] \right. \right. \\
& \quad \left. \left. - \operatorname{Tr}_s \left[(N_{\mathbf{V}}^Y + \frac{1}{2} \dim N_{Y/X}) \exp(-\nabla^{H(Y,\eta|Y),2}) \right] \right) \right) \frac{dT du}{Tu}.
\end{aligned}$$

By (6.92), (6.93), we see that as $T_0 \rightarrow +\infty$,

$$\begin{aligned}
 & \Phi(\bar{\partial}\mu^1 + \partial\nu^1) - \frac{\bar{\partial}\partial}{i\pi}\Phi\lambda^1 \\
 & - \left[2\Phi\bar{\partial} \int_{\epsilon}^{+\infty} \frac{1}{2} \dim N_{Y/X} \frac{\partial}{\partial b} \operatorname{Tr}_s \left[\exp(-B_{u^2}^{W,2} - bu \frac{\partial}{\partial u} B_{u^2}^{W'}) \right]_{b=0} \frac{du}{u} \right. \\
 & + 2\Phi\partial \int_{\epsilon}^{+\infty} \frac{1}{2} \dim N_{Y/X} \frac{\partial}{\partial b} \operatorname{Tr}_s \left[\exp(-B_{u^2}^{W,2} - bu \frac{\partial}{\partial u} B_{u^2}^{W''}) \right]_{b=0} \frac{du}{u} \\
 (6.94) \quad & + \frac{\bar{\partial}\partial}{i\pi}\Phi \left(\int_{\epsilon}^1 \frac{1}{2} \dim N_{Y/X} \operatorname{Tr}_s \left[(N_{u^2}^W + \frac{1}{2} \dim N_{Y/X}) \exp(-B_{u^2}^{W,2}) \right] \frac{du}{u} \right. \\
 & + \int_1^{+\infty} \frac{1}{2} \dim N_{Y/X} \left(\operatorname{Tr}_s \left[(N_{u^2}^W + \frac{1}{2} \dim N_{Y/X}) \exp(-B_{u^2}^{W,2}) \right] \right. \\
 & \left. \left. - \operatorname{Tr}_s \left[(N_{\mathbf{V}}^Y + \frac{1}{2} \dim N_{Y/X}) \exp(-\nabla^{H(Y, \eta|_Y), 2}) \right] \right) \frac{du}{u} \right) \log(T_0) \\
 & \left. \rightarrow \Phi(\bar{\partial}\mu^2 + \partial\nu^2) - \frac{\bar{\partial}\partial}{i\pi}\Phi\lambda^2. \right.
 \end{aligned}$$

$\gamma) \quad \epsilon \rightarrow 0$

1. The terms μ^2 and ν^2 Clearly

$$\begin{aligned}
 (6.95) \quad & \int_{\substack{\epsilon \leq u \leq 1 \\ 1 \leq T < +\infty}} \left(\frac{\partial}{\partial b} \operatorname{Tr}_s \left[N_{\mathbf{H}} \exp(-B_{u,T}^2 - bu \frac{\partial}{\partial u} B_{u^2}^V) \right]_{b=0} \right. \\
 & \left. - \frac{1}{2} \dim N_{Y/X} \frac{\partial}{\partial b} \operatorname{Tr}_s \left[\exp(-B_{u^2}^{W,2} - bu \frac{\partial}{\partial u} B_{u^2}^W) \right]_{b=0} \right) \frac{dT du}{Tu} \\
 & = \frac{1}{4} \int_{\epsilon^2}^1 \frac{du}{u} \int_u^{+\infty} (\pi'_{u,T} - \pi'_u) \frac{dT}{T}.
 \end{aligned}$$

Then

$$\begin{aligned}
 (6.96) \quad & \int_{\epsilon^2}^1 \frac{du}{u} \int_u^{+\infty} (\pi'_{u,T} - \pi'_u) \frac{dT}{T} = \int_{\epsilon^2}^1 \frac{du}{u} \int_u^1 (\pi'_{u,T} - \pi'_u) \frac{dT}{T} \\
 & + \int_{\epsilon^2}^1 \frac{du}{u} \int_u^{+\infty} (\pi'_{u,T/u} - \pi'_u) \frac{dT}{T}.
 \end{aligned}$$

Also by using the techniques of [14, Theorem 2.11], we get the counterpart as $u \rightarrow 0$ of (6.89), i.e. as $u \rightarrow 0$,

$$(6.97) \quad \pi'_u = \mathcal{O}(u), \pi''_u = \mathcal{O}(u).$$

By (6.76), Theorem 6.17 and (6.97), as $\varepsilon \rightarrow 0$,

$$(6.98) \quad \int_{\varepsilon^2}^1 \frac{du}{u} \int_u^1 (\pi'_{u,T} - \pi'^*_u) \frac{dT}{T} \rightarrow \int_0^1 \frac{du}{u} \int_u^1 (\pi'_{u,T} - \pi'^*_u) \frac{dT}{T}.$$

Also, using Theorem 5.29, we get

$$(6.99) \quad \int_{\varepsilon^2}^1 \frac{du}{u} \int_u^{+\infty} (\pi'_{u,T/u} - \pi'^*_u) \frac{dT}{T} = \int_{\varepsilon^2}^1 \frac{du}{u} \int_u^1 (\pi'_{u,T/u} - \pi'_T - \pi'^*_u) \frac{dT}{T} \\ + \int_{\varepsilon^2}^1 \frac{du}{u} \int_1^{+\infty} (\pi'_{u,T/u} - \pi'_T - \pi'^*_u) \frac{dT}{T} \\ + \int_{\varepsilon^2}^1 \frac{du}{u} \int_u^{+\infty} \pi'_T \frac{dT}{T}.$$

By Theorem 5.29 and by (6.76) and Theorem 6.17, for $0 < u \leq 1$, $u \leq T \leq 1$,

$$(6.100) \quad \left| \pi'_{u,T/u} \right| \leq C(u+T)^\gamma \leq C'T^\gamma, \\ \left| \pi'_T \right| \leq CT.$$

Also by Theorem 6.18, for $0 < u \leq 1$, $u \leq T \leq 1$,

$$(6.101) \quad \left| \pi'_{u,T/u} - \pi'_T \right| \leq \frac{Cu^\alpha}{T^\beta}.$$

From (6.100), (6.101), we deduce that there is $\alpha' \in]0, 1]$, such that for $0 < u \leq 1$, $u \leq T \leq 1$,

$$(6.102) \quad \left| \pi'_{u,T/u} - \pi'_T \right| \leq Cu^{\alpha'}.$$

By (6.97), (6.102), we find that as $\varepsilon \rightarrow 0$,

$$(6.103) \quad \int_{\varepsilon^2}^1 \frac{du}{u} \int_u^1 (\pi'_{u,T/u} - \pi'_T - \pi'^*_u) \frac{dT}{T} \\ \rightarrow \int_0^1 \frac{du}{u} \int_u^1 (\pi'_{u,T/u} - \pi'_T - \pi'^*_u) \frac{dT}{T}.$$

By Theorem 6.18, for $0 < u \leq 1$, $T \geq 1$,

$$(6.104) \quad \left| \pi'_{u,T/u} - \pi'_T \right| \leq Cu^\rho.$$

Also by Theorems 5.29 and 6.19, for $0 < u \leq 1$, $T \geq 1$,

$$(6.105) \quad \left| \pi'_{u,T/u} - \pi'^*_u \right| \leq \frac{C}{T^\delta}, \\ \left| \pi'_T \right| \leq \frac{C}{\sqrt{T}}.$$

By (6.97), (6.104), (6.105), we see that for $0 < u \leq 1$, $T \geq 1$,

$$(6.106) \quad \left| \pi'_{u,T/u} - \pi'_T - \pi'^*_u \right| \leq \frac{Cu^{\rho/2}}{T^{\delta/2}}.$$

Using (6.106), we see that as $\varepsilon \rightarrow 0$,

$$(6.107) \quad \int_{\varepsilon^2}^1 \frac{du}{u} \int_1^{+\infty} (\pi'_{u,T/u} - \pi'_T - \pi'^*_u) \frac{dT}{T} \rightarrow \int_0^1 \frac{du}{u} \int_1^{+\infty} (\pi'_{u,T/u} - \pi'_T - \pi'^*_u) \frac{dT}{T}.$$

By Theorem 5.29 and by (6.99), (6.103), (6.107), we find that as $\varepsilon \rightarrow 0$,

$$(6.108) \quad \int_{\varepsilon^2}^1 \frac{du}{u} \int_u^{+\infty} (\pi'_{u,T/u} - \pi'^*_u) \frac{dT}{T} + \int_0^{+\infty} \pi'_T \frac{dT}{T} \log(\varepsilon^2) \\ \rightarrow \int_0^1 \frac{du}{u} \int_u^{+\infty} (\pi'_{u,T/u} - \pi'_T - \pi'^*_u) \frac{dT}{T} \\ + \int_0^1 \pi'_T \log(T) \frac{dT}{T}.$$

By (6.92), (6.95), (6.108), we see that

$$(6.109) \quad \mu^2 + \int_0^{+\infty} \pi'_T \frac{dT}{T} \log(\varepsilon) \rightarrow \mu^3 = \\ \frac{1}{2} \int_0^1 \frac{du}{u} \int_u^{+\infty} (\pi'_{u,T/u} - \pi'_T - \pi'^*_u) \frac{dT}{T} \\ + \frac{1}{2} \int_0^1 \pi'_T \log(T) \frac{dT}{T} + 2 \int_{\substack{1 \leq u < +\infty \\ 1 \leq T < +\infty}} \left(\frac{\partial}{\partial b} \text{Tr}_s \left[N_{\mathbf{H}} \exp(-B_{u,T}^2 - bu \frac{\partial}{\partial u} B_{u^2}^{V'}) \right] \right)_{b=0} \\ - \frac{\partial}{\partial b} \text{Tr}_s \left[P_T N_{\mathbf{H}} P_T \exp(-\nabla_T^{H(X,\xi|x),2} - b \nabla_T^{H(X,\xi|x)'} P_T N_{\mathbf{V}}^X P_T) \right]_{b=0} \\ - \frac{1}{2} \dim N_{Y/X} \frac{\partial}{\partial b} \text{Tr}_s \left[\exp(-B_{u^2}^{W,2} - bu \frac{\partial}{\partial u} B_{u^2}^{W'}) \right]_{b=0} \right) \frac{dT du}{Tu}.$$

A similar result holds for ν^2 , so that as $\varepsilon \rightarrow 0$,

$$(6.110) \quad \nu^2 + \int_0^{+\infty} \pi''_T \frac{dT}{T} \log(\varepsilon) \rightarrow \nu^3.$$

2. The term λ^2 Clearly

$$\begin{aligned}
 (6.111) \quad & \int_{\substack{\varepsilon \leq u \leq 1 \\ 1 \leq T < +\infty}} \left(\frac{\partial}{\partial b} \text{Tr}_s [N_{\mathbf{H}} \exp(-B_{u,T}^2 - bN_{u^2}^V)]_{b=0} \right. \\
 & \left. + \frac{1}{2} \dim N_{Y/X} \text{Tr}_s \left[N_{u^2}^W + \frac{1}{2} \dim N_{Y/X} \exp(-B_{u^2}^{W,2}) \right] \right) \frac{dT du}{Tu} \\
 & = \frac{1}{4} \int_{\varepsilon^2}^1 \frac{du}{u} \int_u^{+\infty} (\kappa_{u,T} - \kappa_u^*) \frac{dT}{T}.
 \end{aligned}$$

As this stage, one would like to proceed as in (6.96)-(6.110). However as $u \rightarrow 0$, $\kappa_{u,T}$ has a singular expansion of the type

$$(6.112) \quad \kappa_{u,T} = \frac{A_T}{u} + B_T + \mathcal{O}(u).$$

Also $\kappa_{u,T/u}$ has a singular expansion of the same type. So we use integration by parts to overcome this difficulty.

Clearly

$$\begin{aligned}
 (6.113) \quad & \int_{\varepsilon^2}^1 \frac{du}{u} \int_u^{+\infty} (\kappa_{u,T} - \kappa_u^*) \frac{dT}{T} = \int_{\varepsilon^2}^1 \frac{du}{u} \int_u^{+\infty} \frac{\partial}{\partial u} (u(\kappa_{u,T} - \kappa_u^*)) \frac{dT}{T} \\
 & + \int_{\varepsilon^2}^1 (-\kappa_{u,u} + \kappa_u^*) \frac{du}{u} + \int_{\varepsilon^2}^{+\infty} (\kappa_{\varepsilon^2,T} - \kappa_{\varepsilon^2}^*) \frac{dT}{T} \\
 & - \int_1^{+\infty} (\kappa_{1,T} - \kappa_1^*) \frac{dT}{T}.
 \end{aligned}$$

We will not control the right-hand side of (6.113) directly, but the $\bar{\partial}\partial$ of this right-hand side. To do this, we will establish intermediate useful formulas, whose purpose is to eliminate the diverging term in (6.113).

Proposition 6.20 — *The following identity holds,*

$$\begin{aligned}
 (6.114) \quad & 2T \frac{\partial}{\partial T} \text{Tr}_s \left[N_u^V \exp(-A^2 \sqrt{u}, \sqrt{T}) \right] = \lambda''_{u,T} - \lambda'_{u,T} \\
 & + \bar{\partial} \pi'_{u,T} + \partial \pi''_{u,T} - 2\bar{\partial}\partial \kappa_{u,T}.
 \end{aligned}$$

Proof. This identity follows from (4.9) and (4.20). □

Theorem 6.21 — *The following identities hold,*

$$\begin{aligned}
 \frac{\partial}{\partial u}(u\kappa_u^*) &= \theta_u^* + \bar{\partial}\partial\eta_u^*, \\
 \frac{\partial}{\partial u}(u\kappa_{u,T}) &= \theta_{u,T} + T\frac{\partial}{\partial T}\eta_{u,T} \\
 (6.115) \quad & - \bar{\partial}\partial\frac{1}{2}\frac{\partial^3}{\partial^2c\partial b}\operatorname{Tr}_s\left[\exp(-A^2_{\sqrt{u},\sqrt{T}} + cN_u^V - bN_{\mathbf{H}})\right]_{b=0} \\
 & + \bar{\partial}\frac{1}{2}\frac{\partial^3}{\partial^2c\partial b}\operatorname{Tr}_s\left[\exp(-A^2_{\sqrt{u},\sqrt{T}} + cN_u^V + b\sqrt{T}v^*)\right]_{b=0} \\
 & + \partial\frac{1}{2}\frac{\partial^3}{\partial^2c\partial b}\operatorname{Tr}_s\left[\exp(-A^2_{\sqrt{u},\sqrt{T}} + cN_u^V + b\sqrt{T}v)\right]_{b=0}.
 \end{aligned}$$

Proof. The first identity in (6.116) was proved in [14, Theorem 2.14]. Now we prove the second identity. Clearly,

$$\begin{aligned}
 (6.116) \quad & \frac{\partial}{\partial u}\operatorname{Tr}_s\left[uN_u^V\exp(-A^2_{\sqrt{u},\sqrt{T}} - bN_{\mathbf{H}})\right] = \operatorname{Tr}_s\left[\frac{\partial}{\partial u}(uN_u^V)\exp(-A^2_{\sqrt{u},\sqrt{T}} - bN_{\mathbf{H}})\right] \\
 & + \frac{\partial}{\partial c}\operatorname{Tr}_s\left[uN_u^V\exp(-A^2_{\sqrt{u},\sqrt{T}} - c\left[A''_{\sqrt{u},\sqrt{T}}, \frac{\partial}{\partial u}A'_{\sqrt{u},\sqrt{T}}\right] \right. \\
 & \quad \left. - c\left[A'_{\sqrt{u},\sqrt{T}}, \frac{\partial}{\partial u}A''_{\sqrt{u},\sqrt{T}}\right] - bN_{\mathbf{H}}\right]_{c=0} \\
 & = \operatorname{Tr}_s\left[\frac{\partial}{\partial u}(uN_u^V)\exp(-A^2_{\sqrt{u},\sqrt{T}} - bN_{\mathbf{H}})\right] \\
 & + \bar{\partial}\operatorname{Tr}_s\left[uN_u^V\exp(-A^2_{\sqrt{u},\sqrt{T}} - d\bar{a}\frac{\partial}{\partial u}A'_{\sqrt{u},\sqrt{T}} - bN_{\mathbf{H}})\right]^{d\bar{a}} \\
 & + \partial\operatorname{Tr}_s\left[uN_u^V\exp(-A^2_{\sqrt{u},\sqrt{T}} - da\frac{\partial}{\partial u}A''_{\sqrt{u},\sqrt{T}} - bN_{\mathbf{H}})\right]^{da} \\
 & + \operatorname{Tr}_s\left[\left[A''_{\sqrt{u},\sqrt{T}}, uN_u^V\right]\exp(-A^2_{\sqrt{u},\sqrt{T}} - d\bar{a}\frac{\partial}{\partial u}A'_{\sqrt{u},\sqrt{T}} - bN_{\mathbf{H}})\right]^{d\bar{a}} \\
 & + \operatorname{Tr}_s\left[\left[A'_{\sqrt{u},\sqrt{T}}, uN_u^V\right]\exp(-A^2_{\sqrt{u},\sqrt{T}} - da\frac{\partial}{\partial u}A''_{\sqrt{u},\sqrt{T}} - bN_{\mathbf{H}})\right]^{da} \\
 & + b\frac{\partial}{\partial c}\operatorname{Tr}_s\left[uN_u^V\exp(-A^2_{\sqrt{u},\sqrt{T}} - d\bar{a}\frac{\partial}{\partial u}A'_{\sqrt{u},\sqrt{T}} - bN_{\mathbf{H}} - c\left[A''_{\sqrt{u},\sqrt{T}}, N_{\mathbf{H}}\right])\right]^{d\bar{a}}_{c=0} \\
 & + b\frac{\partial}{\partial c}\operatorname{Tr}_s\left[uN_u^V\exp(-A^2_{\sqrt{u},\sqrt{T}} - da\frac{\partial}{\partial u}A''_{\sqrt{u},\sqrt{T}} - bN_{\mathbf{H}} - c\left[A'_{\sqrt{u},\sqrt{T}}, N_{\mathbf{H}}\right])\right]^{da}_{c=0}.
 \end{aligned}$$

□

By (2.33),

$$\begin{aligned}
(6.117) \quad & \text{Tr}_s \left[uN_u^V \exp(-A^2_{\sqrt{u},\sqrt{T}} - d\bar{a} \frac{\partial}{\partial u} A'_{\sqrt{u},\sqrt{T}} - bN_{\mathbf{H}}) \right]^{d\bar{a}} \\
&= \frac{1}{2} \text{Tr}_s \left[N_u^V \exp(-A^2_{\sqrt{u},\sqrt{T}} - d\bar{a} [A'_{\sqrt{u},\sqrt{T}}, N_u^V] - bN_{\mathbf{H}}) \right]^{d\bar{a}} \\
&= -\partial \frac{1}{4} \frac{\partial^2}{\partial c^2} \text{Tr}_s \left[\exp(-A^2_{\sqrt{u},\sqrt{T}} + cN_u^V - bN_{\mathbf{H}}) \right]_{c=0} \\
&\quad - \frac{1}{4} b \frac{\partial^3}{\partial c^2 \partial b'} \text{Tr}_s \left[\exp(-A^2_{\sqrt{u},\sqrt{T}} + cN_u^V - bN_{\mathbf{H}} + b' [A'_{\sqrt{u},\sqrt{T}}, N_{\mathbf{H}}]) \right]_{c=0}^{b'=0}.
\end{aligned}$$

In the corresponding equality with $da \frac{\partial}{\partial u} A''_{\sqrt{u},\sqrt{T}}$, signs are changed in the right-hand side of (6.117).

By differentiating (6.116) at $b = 0$, and using (6.117), we get

$$\begin{aligned}
(6.118) \quad & \frac{\partial}{\partial u} (u\kappa_{u,T}) = \frac{\partial}{\partial b} \text{Tr}_s \left[\frac{\partial}{\partial u} (uN_u^V) \exp(-A^2_{\sqrt{u},\sqrt{T}} - bN_{\mathbf{H}}) \right]_{b=0} \\
&\quad - \bar{\partial} \partial \frac{1}{2} \frac{\partial^3}{\partial c^2 \partial b} \text{Tr}_s \left[\exp(-A^2_{\sqrt{u},\sqrt{T}} + cN_u^V - bN_{\mathbf{H}}) \right]_{c=0}^{b=0} \\
&\quad + \bar{\partial} \frac{1}{4} \frac{\partial^3}{\partial c^2 \partial b} \text{Tr}_s \left[\exp(-A^2_{\sqrt{u},\sqrt{T}} + cN_u^V + b\sqrt{T}v^*) \right] \\
&\quad + \partial \frac{1}{4} \frac{\partial^3}{\partial c^2 \partial b} \text{Tr}_s \left[\exp(-A^2_{\sqrt{u},\sqrt{T}} + cN_u^V + b\sqrt{T}v) \right]_{c=0}^{b=0} \\
&\quad + \frac{\partial}{\partial b} \text{Tr}_s \left[\exp(-A^2_{\sqrt{u},\sqrt{T}} - 2da u \frac{\partial}{\partial u} A''_{u,T} \right. \\
&\quad \quad \left. - 2d\bar{a} u \frac{\partial}{\partial u} A'_{u,T} - bN_{\mathbf{H}}) \right]_{b=0}^{dad\bar{a}} \\
&\quad + \frac{\partial}{\partial b} \text{Tr}_s \left[uN_u^V \exp(-A^2_{\sqrt{u},\sqrt{T}} - d\bar{a} \frac{\partial}{\partial u} A'_{\sqrt{u},\sqrt{T}} - b [A''_{\sqrt{u},\sqrt{T}}, N_{\mathbf{H}}]) \right]_{b=0}^{d\bar{a}} \\
&\quad + \frac{\partial}{\partial b} \text{Tr}_s \left[uN_u^V \exp(-A^2_{\sqrt{u},\sqrt{T}} - da \frac{\partial}{\partial u} A''_{\sqrt{u},\sqrt{T}} - b [A'_{\sqrt{u},\sqrt{T}}, N_{\mathbf{H}}]) \right]_{b=0}^{da}.
\end{aligned}$$

Also, as in (6.118), we get

$$\begin{aligned}
(6.119) \quad & \text{Tr}_s \left[uN_u^V \exp(-A^2_{\sqrt{u},\sqrt{T}} - d\bar{a} \frac{\partial}{\partial u} A'_{\sqrt{u},\sqrt{T}} - b [A''_{\sqrt{u},\sqrt{T}}, N_{\mathbf{H}}]) \right]^{d\bar{a}} \\
&= -\partial \frac{1}{4} \frac{\partial^2}{\partial c^2} \text{Tr}_s \left[\exp(-A^2_{\sqrt{u},\sqrt{T}} + cN_u^V - b\sqrt{T}v) \right]_{c=0}^{b=0} + \frac{1}{4} b \frac{\partial^3}{\partial c^2 \partial b'} \\
&\quad \text{Tr}_s \left[\exp \left(-A^2_{\sqrt{u},\sqrt{T}} + cN_u^V - b\sqrt{T}v - 2b'T \left[A'_{\sqrt{u},\sqrt{T}}, \frac{\partial}{\partial T} A''_{\sqrt{u},\sqrt{T}} \right] \right) \right]_{c=0}^{b'=0}.
\end{aligned}$$

By differentiating (6.119) at $b = 0$, we get

$$(6.120) \quad \frac{\partial}{\partial b} \operatorname{Tr}_s \left[u N_u^V \exp(-A^2_{\sqrt{u}, \sqrt{T}} - d\bar{a} \frac{\partial}{\partial u} A'_{\sqrt{u}, \sqrt{T}} - b [A''_{\sqrt{u}, \sqrt{T}}, N_{\mathbf{H}}]) \right]_{b=0}^{d\bar{a}} \\ = \partial^{\frac{3}{4}} \frac{\partial^3}{\partial^2 c \partial b} \operatorname{Tr}_s \left[\exp(-A^2_{\sqrt{u}, \sqrt{T}} + c N_u^V + b \sqrt{T} v) \right]_{c=0} \\ + \frac{1}{4} \frac{\partial^3}{\partial^2 c \partial b'} \operatorname{Tr}_s \left[\exp \left(-A^2_{\sqrt{u}, \sqrt{T}} + c N^V u - 2b' T \left[A'_{\sqrt{u}, \sqrt{T}}, \frac{\partial}{\partial T} A''_{\sqrt{u}, \sqrt{T}} \right] \right) \right]_{c=0}^{b'=0}.$$

In the corresponding equality with $da \frac{\partial}{\partial u} A''_{\sqrt{u}, \sqrt{T}}$, ∂ is replaced by $\bar{\partial}$, $\sqrt{T}v$ by $\sqrt{T}v^*$ and $[A'_{\sqrt{u}, \sqrt{T}}, \frac{\partial}{\partial T} A''_{\sqrt{u}, \sqrt{T}}]$ by $[A''_{\sqrt{u}, \sqrt{T}}, \frac{\partial}{\partial T} A'_{\sqrt{u}, \sqrt{T}}]$.

Now using Theorems 6.19 and 6.21, we get

$$(6.121) \quad \bar{\partial} \partial \int_{\varepsilon^2}^1 \frac{du}{u} \int_u^{+\infty} \frac{\partial}{\partial u} (u(\kappa_{u,T} - \kappa_u^*)) \frac{dT}{T} = \\ \bar{\partial} \partial \left[\int_{\varepsilon^2}^1 \frac{du}{u} \int_u^{+\infty} (\theta_{u,T} - \theta_u^*) \frac{dT}{T} + \int_{\varepsilon^2}^1 (-\eta_{u,u} + \eta_u^*) \frac{du}{u} \right].$$

To the first term in the right-hand side of (6.122), we apply the trick already used for μ^2, ν^2 . Namely we write

$$(6.122) \quad \int_{\varepsilon^2}^1 \frac{du}{u} \int_u^{+\infty} (\theta_{u,T} - \theta_u^*) \frac{dT}{T} = \int_{\varepsilon^2}^1 \frac{du}{u} \int_u^1 (\theta_{u,T} - \theta_u^*) \frac{dT}{T} \\ + \int_{\varepsilon^2}^1 \frac{du}{u} \int_u^{+\infty} (\theta_{u,T/u} - \theta_u^*) \frac{dT}{T}.$$

Also

$$(6.123) \quad \int_{\varepsilon^2}^1 \frac{du}{u} \int_u^1 (\theta_{u,T} - \theta_u^*) \frac{dT}{T} = \int_{\varepsilon^2}^1 \frac{du}{u} \int_u^1 (\theta_{u,T} - \theta_{0,T} - \theta_u^* + \theta_0^*) \frac{dT}{T} \\ + \int_{\varepsilon^2}^1 \frac{du}{u} \int_u^1 (\theta_{0,T} - \theta_0^*) \frac{dT}{T}.$$

One verifies easily that as $u \rightarrow 0$,

$$(6.124) \quad \theta_u^* = \theta_0^* + \mathcal{O}(u).$$

By Theorem 6.17 and by (6.123), (6.124), we see that as $\varepsilon \rightarrow 0$,

$$(6.125) \quad \int_{\varepsilon^2}^1 \frac{du}{u} \int_u^1 (\theta_{u,T} - \theta_u^*) \frac{dT}{T} + \frac{1}{2} (-\theta_{0,0} + \theta_0^*) \log^2(\varepsilon^2) \\ + \int_0^1 (\theta_{0,T} - \theta_{0,0}) \frac{dT}{T} \log(\varepsilon^2) \\ \rightarrow \int_0^1 \frac{du}{u} \int_u^1 (\theta_{u,T} - \theta_{0,T} - \theta_u^* + \theta_0^*) \frac{dT}{T} + \int_0^1 (\theta_{0,T} - \theta_{0,0}) \log(T) \frac{dT}{T}.$$

Also by Theorem 5.29 and (6.78),

$$(6.126) \quad \int_{\varepsilon^2}^1 \frac{du}{u} \int_u^{+\infty} (\theta_{u,T/u} - \theta_u^*) \frac{dT}{T} =$$

$$\int_{\varepsilon^2}^1 \frac{du}{u} \int_u^1 (\theta_{u,T/u} - \theta_{0,T/u} - \theta_T + \theta_0) \frac{dT}{T}$$

$$+ \int_{\varepsilon^2}^1 \frac{du}{u} \int_u^1 (\theta_T - \theta_0) \frac{dT}{T} + \int_{\varepsilon^2}^1 \frac{du}{u} \int_1^{1/u} \theta_{0,T} \frac{dT}{T}$$

$$+ \int_{\varepsilon^2}^1 \theta_u^* \log(u) \frac{du}{u} + \int_{\varepsilon^2}^1 \frac{du}{u} \int_1^{+\infty} (\theta_{u,T/u} - \theta_T - \theta_u^* + \theta_0^*) \frac{dT}{T}$$

$$- \int_1^{+\infty} (\theta_T - \theta_\infty) \frac{dT}{T} \log(\varepsilon^2).$$

By Theorems 5.29 and 6.17, for $0 < u \leq 1$, $u \leq T \leq 1$,

$$(6.127) \quad |\theta_{u,T/u} - \theta_{0,T/u}| \leq C(u+T)^\gamma \leq C'T^\gamma,$$

$$|\theta_T - \theta_0| \leq C'T.$$

By Theorems 3.6 and 6.18, and by (6.78), for $0 < u \leq 1$, $u \leq T \leq 1$,

$$(6.128) \quad |\theta_{u,T/u} - \theta_T| \leq \frac{Cu^\alpha}{T^\beta},$$

$$|\theta_{0,T/u} - \theta_0| \leq C\left(\frac{u}{T}\right)^{1/2}.$$

From (6.127), (6.128), we find that there exists $\alpha' \in]0, 1]$ such that for $0 < u \leq 1$, $u \leq T \leq 1$

$$(6.129) \quad |\theta_{u,T/u} - \theta_{0,T/u} - \theta_T + \theta_0| \leq Cu^{\alpha'}.$$

By (6.129), we see that as $\varepsilon \rightarrow 0$,

$$(6.130) \quad \int_{\varepsilon^2}^1 \frac{du}{u} \int_u^1 (\theta_{u,T/u} - \theta_{0,T/u} - \theta_T + \theta_0) \frac{dT}{T} \rightarrow$$

$$\int_0^1 \frac{du}{u} \int_u^1 (\theta_{u,T/u} - \theta_{0,T/u} - \theta_T + \theta_0) \frac{dT}{T}.$$

By Theorems 5.29, 6.18 and 6.19, for $0 < u \leq 1$, $T \geq 1$,

$$(6.131) \quad |\theta_{u,T/u} - \theta_T| \leq Cu^\rho,$$

$$|\theta_{u,T/u} - \theta_u^*| \leq \frac{C}{T^\delta},$$

$$|\theta_T - \theta_\infty| \leq \frac{C}{\sqrt{T}}.$$

Using (6.78), from (6.124)-(6.131), we see that for $0 < u \leq 1$, $T \geq 1$

$$(6.132) \quad |\theta_{u,T/u} - \theta_T - \theta_u^* + \theta_0^*| \leq \frac{Cu^{\alpha'}}{T^{\beta'}}.$$

From (6.132), we find that as $\varepsilon \rightarrow 0$,

$$(6.133) \quad \int_{\varepsilon^2}^1 \frac{du}{u} \int_1^{+\infty} (\theta_{u,T/u} - \theta_T - \theta_u^* + \theta_0^*) \frac{dT}{T} \rightarrow \int_0^1 \frac{du}{u} \int_1^{+\infty} (\theta_{u,T/u} - \theta_T - \theta_u^* + \theta_0^*) \frac{dT}{T}.$$

Using (6.126), (6.130), (6.133), we see that as $\varepsilon \rightarrow 0$,

$$(6.134) \quad \int_{\varepsilon^2}^1 \frac{du}{u} \int_u^{+\infty} (\theta_{u,T/u} - \theta_u^*) \frac{dT}{T} + \frac{1}{2}(\theta_0^* - \theta_{0,\infty}) \log^2(\varepsilon^2) \\ + \left(\int_1^{+\infty} (\theta_{0,T} - \theta_{0,\infty}) \frac{dT}{T} + \int_0^1 (\theta_T - \theta_0) \frac{dT}{T} + \int_1^{+\infty} (\theta_T - \theta_\infty) \frac{dT}{T} \right) \\ \log(\varepsilon^2) \rightarrow \int_0^1 \frac{du}{u} \int_u^1 (\theta_{u,T/u} - \theta_{0,T/u} - \theta_T + \theta_0) \frac{dT}{T} \\ + \int_0^1 \frac{du}{u} \int_1^{+\infty} (\theta_{u,T/u} - \theta_T - \theta_u^* + \theta_0^*) \frac{dT}{T} \\ + \int_0^1 (\theta_T - \theta_0) \log(T) \frac{dT}{T} - \int_1^{+\infty} (\theta_{0,T} - \theta_{0,\infty}) \log(T) \frac{dT}{T}.$$

By (6.122), (6.125), (6.134), we see that as $\varepsilon \rightarrow 0$,

$$(6.135) \quad \int_{\varepsilon^2}^1 \frac{du}{u} \int_u^{+\infty} (\theta_{u,T} - \theta_u^*) \frac{dT}{T} + \frac{1}{2}(2\theta_0^* - \theta_{0,0} - \theta_{0,\infty}) \log^2(\varepsilon^2) \\ + \left(\int_0^1 (\theta_{0,T} - \theta_{0,0}) \frac{dT}{T} + \int_1^{+\infty} (\theta_{0,T} - \theta_{0,\infty}) \frac{dT}{T} \right. \\ \left. + \int_0^1 (\theta_T - \theta_0) \frac{dT}{T} + \int_1^{+\infty} (\theta_T - \theta_\infty) \frac{dT}{T} \right) \log(\varepsilon^2) \\ \rightarrow \int_0^1 \frac{du}{u} \int_u^1 (\theta_{u,T} - \theta_{0,T} - \theta_u^* + \theta_0^*) \frac{dT}{T} \\ + \int_0^1 \frac{du}{u} \int_u^1 (\theta_{u,T/u} - \theta_{0,T/u} - \theta_T + \theta_0) \frac{dT}{T} \\ + \int_0^1 \frac{du}{u} \int_1^{+\infty} (\theta_{u,T/u} - \theta_T - \theta_u^* + \theta_0^*) \frac{dT}{T} \\ + \int_0^1 (\theta_{0,T} - \theta_{0,0}) \log(T) \frac{dT}{T} - \int_1^{+\infty} (\theta_{0,T} - \theta_{0,\infty}) \log(T) \frac{dT}{T} \\ + \int_0^1 (\theta_T - \theta_0) \log(T) \frac{dT}{T}.$$

Clearly

$$(6.136) \quad \kappa_{u,u} + \eta_{u,u} = \frac{1}{2} \frac{\partial^2}{\partial c^2} \operatorname{Tr}_s \left[\exp(-A^2_{\sqrt{u}, \sqrt{T}} + c(N_u^V - N_{\mathbf{H}})) \right]_{c=0} \\ - \frac{1}{2} \frac{\partial^2}{\partial c^2} \operatorname{Tr}_s \left[\exp(-A^2_{\sqrt{u}, \sqrt{T}} + cN_{\mathbf{H}}) \right]_{c=0}.$$

Now by [14, Theorems 2.14 and 2.16], we know that there are forms $H_{-2}, H_{-1}, H_0 \in P^S$ such that as $u \rightarrow 0$,

$$(6.137) \quad \Phi \frac{1}{2} \frac{\partial^2}{\partial c^2} \operatorname{Tr}_s \left[\exp(-A^2_{\sqrt{u}, \sqrt{T}} + c(N_u^V - N_{\mathbf{H}})) \right]_{c=0} = \\ \frac{H_{-2}}{u^2} + \frac{H_{-1}}{u} + H_0 + \mathcal{O}(u),$$

and moreover,

$$(6.138) \quad \frac{\bar{\partial}\partial}{2i\pi} H_{-2} = 0, \quad \frac{\bar{\partial}\partial}{2i\pi} H_{-1} = 0, \\ \frac{\bar{\partial}\partial}{2i\pi} H_0 = -D_0^V + \int_X (\dim X \operatorname{Td}(TX, g^{TX}) - \operatorname{Td}'(TX, g^{TX})) \operatorname{ch}(\xi, g^\xi) \\ - \int_X \operatorname{Td}(TX, g^{TX}) \operatorname{ch}'(\xi, g^\xi).$$

Also by proceeding as in [4, Section 4], we see that as $u \rightarrow 0$,

$$(6.139) \quad \Phi \frac{1}{2} \frac{\partial^2}{\partial c^2} \operatorname{Tr}_s \left[\exp(-A^2_{\sqrt{u}, \sqrt{T}} + cN_{\mathbf{H}}) \right]_{c=0} \\ = \frac{1}{2} \int_X \operatorname{Td}(TX, g^{TX}) \Phi \operatorname{Tr}_s [N_{\mathbf{H}}^2 \exp(-\nabla^{\xi, 2})] + \mathcal{O}(u).$$

Clearly the constant coefficient of (6.139) is ∂ and $\bar{\partial}$ closed. From (6.136)-(6.139), we find that there are forms $K_{-2}, K_{-1}, K_0 \in P^S$ such that as $u \rightarrow 0$,

$$(6.140) \quad \Phi(\kappa_{u,u} + \eta_{u,u}) = \frac{K_{-2}}{u^2} + \frac{K_{-1}}{u} + K_0 + \mathcal{O}(u),$$

and moreover

$$(6.141) \quad \frac{\bar{\partial}\partial}{2i\pi} K_{-2} = 0, \quad \frac{\bar{\partial}\partial}{2i\pi} K_{-1} = 0, \\ \frac{\bar{\partial}\partial}{2i\pi} K_0 = -D_0^V + \int_X (\dim X \operatorname{Td}(TX, g^{TX}) - \operatorname{Td}'(TX, g^{TX})) \operatorname{ch}(\xi, g^\xi) \\ - \int_X \operatorname{Td}(TX, g^{TX}) \operatorname{ch}'(\xi, g^\xi).$$

Clearly

$$(6.142) \quad \kappa_u^* + \eta_u^* = \frac{1}{2} \frac{\partial^2}{\partial c^2} \text{Tr}_s [\exp(-B_u^{W,2} + cN_u^W)]_{c=0} - \frac{1}{2} \frac{\partial^2}{\partial c^2} \text{Tr}_s \left[\exp(-B_u^{W,2} + \frac{c}{2} \dim N_{Y/X}) \right]_{c=0}.$$

By using again [14, Theorems 2.14 and 2.16], we see that there are forms $L_{-2}, L_{-1}, L_0 \in P^S$, such that as $u \rightarrow 0$

$$(6.143) \quad \Phi(\kappa_u^* + \eta_u^*) = \frac{L_{-2}}{u^2} + \frac{L_{-1}}{u} + L_0 + \mathcal{O}(u),$$

and that

$$(6.144) \quad \frac{\bar{\partial}\partial}{2i\pi} L_{-2} = 0, \quad \frac{\bar{\partial}\partial}{2i\pi} L_{-1} = 0, \\ \frac{\bar{\partial}\partial}{2i\pi} L_0 = -C_0^W + \int_Y (\dim Y \text{Td}(TY, g^{TY}) - \text{Td}'(TY, g^{TY})) \text{ch}(\eta, g^\eta).$$

By (6.140), (6.143) we see that as $u \rightarrow 0$,

$$(6.145) \quad \Phi \left(\int_{\varepsilon^2}^1 (-\kappa_{u,u} + \kappa_u^*) \frac{du}{u} + \int_{\varepsilon^2}^1 (-\eta_{u,u} + \eta_u^*) \frac{du}{u} \right) \\ + (K_{-2} - L_{-2}) \frac{1}{2\varepsilon^2} + (K_{-1} - L_{-1}) \frac{1}{\varepsilon} - 2(K_0 - L_0) \log(\varepsilon) \\ \rightarrow A_1 = - \int_0^1 \Phi(\kappa_{u,u} + \eta_{u,u}) - \frac{K_{-2}}{u^2} - \frac{K_{-1}}{u} - K_0 \frac{du}{u} \\ + \int_0^1 \left(\Phi(\kappa_u^* + \eta_u^* - \frac{L_{-2}}{u^2} - \frac{L_{-1}}{u} - L_0) \frac{du}{u} \right. \\ \left. + \frac{1}{2}(K_{-2} - L_{-2}) + (K_{-1} - L_{-1}) \right).$$

From (6.141), (6.144), (6.145), we find that as $u \rightarrow 0$,

$$(6.146) \quad \frac{\bar{\partial}\partial}{2i\pi} \Phi \left[\int_{\varepsilon^2}^1 (-\kappa_{u,u} + \kappa_u^*) \frac{du}{u} + \int_{\varepsilon^2}^1 (-\eta_{u,u} + \eta_u^*) \frac{du}{u} \right] \\ + 2 \left(D_0^Y - \int_X (\dim X \text{Td}(TX, g^{TX}) - \text{Td}'(TX, g^{TX})) \text{ch}(\xi, g^\xi) \right. \\ \left. + \int_X \text{Td}(TX, g^{TX}) \text{ch}'(\xi, g^\xi) - C_0^W + \int_Y (\dim Y \text{Td}(TY, g^{TY}) \right. \\ \left. - \text{Td}'(TY, g^{TY})) \text{ch}(\eta, g^\eta) \right) \log(\varepsilon) \rightarrow \frac{\bar{\partial}\partial}{2i\pi} A_1.$$

By (6.75), we get

$$(6.147) \quad \bar{\partial}\partial\kappa_u^* = \frac{1}{2} (\bar{\partial}\pi_u'^* + \partial\pi_u''^*).$$

Using Theorems 6.5 and 6.19, Proposition 6.20 and (6.147), we get

$$\begin{aligned}
 (6.148) \quad \bar{\partial}\partial \int_{\varepsilon^2}^{+\infty} (\kappa_{\varepsilon^2, T} - \kappa_{\varepsilon^2}^*) \frac{dT}{T} &= \text{Tr}_s [N_{\varepsilon^2}^V \exp(-A_{\varepsilon, \varepsilon}^2)] \\
 &\quad - \text{Tr}_s \left[(N_{\varepsilon^2}^W + \frac{1}{2} \dim N_{Y/X}) \exp(-B_{\varepsilon^2}^{W,2}) \right] \\
 &\quad + \frac{1}{2} \int_{\varepsilon^2}^{+\infty} (\lambda''_{\varepsilon^2, T} - \lambda'_{\varepsilon^2, T}) \frac{dT}{T} \\
 &\quad + \frac{1}{2} \bar{\partial} \int_{\varepsilon^2}^{+\infty} (\pi'_{\varepsilon^2, T} - \pi_{\varepsilon^2}^{'*}) \frac{dT}{T} + \frac{1}{2} \partial \int_{\varepsilon^2}^{+\infty} (\pi''_{\varepsilon^2, T} - \pi_{\varepsilon^2}^{''*}) \frac{dT}{T}.
 \end{aligned}$$

Clearly

$$(6.149) \quad \text{Tr}_s [N_{\varepsilon^2}^V \exp(-A_{\varepsilon, \varepsilon}^2)] = \text{Tr}_s [(N_{\varepsilon^2}^V - N_{\mathbf{H}}) \exp(-A_{\varepsilon, \varepsilon}^2)] + \text{Tr}_s [N_{\mathbf{H}} \exp(-A_{\varepsilon, \varepsilon}^2)].$$

Using [14, eq. (2.71)] and Theorem 6.4, as $\varepsilon \rightarrow 0$,

$$\begin{aligned}
 (6.150) \quad \Phi \text{Tr}_s [(N_{\varepsilon^2}^V - N_{\mathbf{H}}) \exp(-A_{\varepsilon, \varepsilon}^2)] &= D_{-1}^V \frac{1}{\varepsilon^2} + D_0^V + \mathcal{O}(\varepsilon^2), \\
 \Phi \text{Tr}_s [N_{\mathbf{H}} \exp(-A_{\varepsilon, \varepsilon}^2)] &= \int_X \text{Td}(TX, g^{TX}) \text{ch}'(\xi, g^\xi) + \mathcal{O}(\varepsilon^2).
 \end{aligned}$$

Also by Theorem 2.17, as $\varepsilon \rightarrow 0$

$$\begin{aligned}
 (9.151) \quad \Phi \text{Tr}_s \left[(N_{\varepsilon^2}^W + \frac{1}{2} \dim N_{Y/X}) \exp(-B_{\varepsilon^2}^{W,2}) \right] &= \\
 \frac{C_{-1}^W}{\varepsilon^2} + C_0^W + \frac{1}{2} \dim N_{Y/X} \int_Y \text{Td}(TY, g^{TY}) \text{ch}(\eta, g^\eta) &+ \mathcal{O}(\varepsilon^2).
 \end{aligned}$$

Using (6.97), Theorems 6.18 and 6.19 and proceeding as in (6.59)-(6.67), as $\varepsilon \rightarrow 0$,

$$\begin{aligned}
 (6.152) \quad \frac{1}{2} \int_{\varepsilon^2}^{+\infty} (\lambda''_{\varepsilon^2, T} - \lambda'_{\varepsilon^2, T}) \frac{dT}{T} &\rightarrow \int_0^{+\infty} \lambda_T \frac{dT}{T}, \\
 \frac{1}{2} \int_{\varepsilon^2}^{+\infty} (\pi'_{\varepsilon^2, T} - \pi_{\varepsilon^2}^{'*}) \frac{dT}{T} &\rightarrow \frac{1}{2} \int_0^{+\infty} \pi'_T \frac{dT}{T}, \\
 \frac{1}{2} \int_{\varepsilon^2}^{+\infty} (\pi''_{\varepsilon^2, T} - \pi_{\varepsilon^2}^{''*}) \frac{dT}{T} &\rightarrow \frac{1}{2} \int_0^{+\infty} \pi''_T \frac{dT}{T}.
 \end{aligned}$$

From (6.148)-(6.152), we see that as $\varepsilon \rightarrow 0$,

$$\begin{aligned}
 (6.153) \quad & \frac{\bar{\partial}\partial}{2i\pi} \int_{\varepsilon^2}^{+\infty} \Phi(\kappa_{\varepsilon^2, T} - \kappa_{\varepsilon^2}^*) \frac{dT}{T} + (C_{-1}^W - D_{-1}^V) \frac{1}{\varepsilon^2} \\
 & \rightarrow D_0^V + \int_Y \text{Td}(TX, g^{TX}) \text{ch}'(\xi, g^\xi) - C_0^W \\
 & \quad - \frac{1}{2} \dim N_{Y/X} \int_Y \text{Td}(TY, g^{TY}) \text{ch}(\eta, g^\eta) \\
 & \quad + \int_0^{+\infty} \Phi \lambda_T \frac{dT}{T} + \frac{1}{2} \Phi \bar{\partial} \int_0^{+\infty} \pi'_T \frac{dT}{T} + \frac{1}{2} \Phi \partial \int_0^{+\infty} \pi''_T \frac{dT}{T}.
 \end{aligned}$$

Now by using Theorem 3.10, (6.141), (6.144), one finds easily that there is a universal form $B_1 \in P^S$ such that

$$\begin{aligned}
 (6.154) \quad & D_0^V + \int_X \text{Td}(TX, g^{TX}) \text{ch}'(\xi, g^\xi) - C_0^W \\
 & - \frac{1}{2} \dim N_{Y/X} \int_Y \text{Td}(TY, g^{TY}) \text{ch}(\eta, g^\eta) = \int_Y \left(\frac{1}{2} \dim N_{Y/X} \text{Td}(TY, g^{TY}) \right. \\
 & \quad \left. + \text{Td}(TX, g^{TX}) (\text{Td}^{-1})'(N_{Y/X}, g^{N_{Y/X}}) \text{ch}(\eta, g^\eta) \right) + \frac{\bar{\partial}\partial}{2i\pi} (B_1).
 \end{aligned}$$

By Theorem 5.11 and Proposition 5.26, we find that there is a universal form $C_1 \in P^W$ such that

$$\begin{aligned}
 (6.155) \quad & \int_0^{+\infty} \Phi \Lambda_T \frac{dT}{T} = -\frac{1}{2} \dim N_{Y/X} \text{Td}(TY, g^{TY}) \\
 & \quad - \text{Td}(TX, g^{TX}) (\text{Td}^{-1})'(N_{Y/X}, g^{N_{Y/X}}) + \frac{\bar{\partial}\partial}{2i\pi} (C_1).
 \end{aligned}$$

Also by Proposition 5.28, there is a universal form $C_2 \in P^W$ such that

$$(6.156) \quad \frac{1}{2} \Phi \bar{\partial} \int_0^{+\infty} \Pi'_T \frac{dT}{T} + \frac{1}{2} \Phi \partial \int_0^{+\infty} \Pi''_T \frac{dT}{T} = + \frac{\bar{\partial}\partial}{2i\pi} (C_2).$$

From (6.153)-(6.156), we deduce that there is a universal form $A_2 \in P^S$ such that when $\varepsilon \rightarrow 0$,

$$(6.157) \quad \frac{\bar{\partial}\partial}{2i\pi} \int_{\varepsilon^2}^{+\infty} \Phi(\kappa_{\varepsilon^2, T} - \kappa_{\varepsilon^2}^*) \frac{dT}{T} + (C_{-1}^W - D_{-1}^V) \frac{1}{\varepsilon^2} \rightarrow \frac{\bar{\partial}\partial}{2i\pi} (A_2).$$

Ultimately, from (6.93), (6.111), (6.113), (6.121), (6.135), (6.146), (6.157) and using the fact that θ_0^* , $\theta_{0,0}$, $\theta_{0,\infty}$ are closed, we see that as there is a canonical form $H \in P^S$

such that as $\varepsilon \rightarrow 0$,

$$\begin{aligned}
 (6.158) \quad & \frac{\bar{\partial}\partial}{i\pi} \Phi \lambda_2 + \frac{1}{2} (C_{-1}^W - D_{-1}^V) \frac{1}{\varepsilon^2} \\
 & + \frac{\bar{\partial}\partial}{2i\pi} \left[\int_0^1 (\theta_{0,T} - \theta_{0,0}) \frac{dT}{T} + \int_1^{+\infty} (\theta_{0,T} - \theta_{0,\infty}) \frac{dT}{T} \right. \\
 & \quad \left. + \int_0^1 (\theta_T - \theta_0) \frac{dT}{T} + \int_1^{+\infty} (\theta_T - \theta_\infty) \frac{dT}{T} \right] \\
 & + \left(D_0^V - \int_X (\dim X \operatorname{Td}(TX, g^{TX}) - \operatorname{Td}'(TX, g^{TX})) \operatorname{ch}(\xi, g^\xi) \right. \\
 & \quad \left. + \int_X \operatorname{Td}(TX, g^{TX}) \operatorname{ch}'(\xi, g^\xi) - C_0^W + \int_Y (\dim Y \operatorname{Td}(TY, g^{TY}) \right. \\
 & \quad \left. - \operatorname{Td}'(TY, g^{TY})) \operatorname{ch}(\eta, g^\eta) \right) \log(\varepsilon) \rightarrow \frac{\bar{\partial}\partial}{i\pi} H.
 \end{aligned}$$

So by (6.109), (6.110), (6.158), we see that there are universal forms μ^3, ν^3, λ^3 such that as $\varepsilon \rightarrow 0$

$$\begin{aligned}
 (6.159) \quad & \Phi(\bar{\partial}\mu^2 + \partial\nu^2) - \frac{\bar{\partial}\partial}{i\pi} \Phi \lambda^2 + \frac{1}{2} (D_{-1}^V - C_{-1}^W) \frac{1}{\varepsilon^2} \\
 & + \left\{ (\Phi \bar{\partial} \int_0^{+\infty} \pi'_T \frac{dT}{T} + \Phi \partial \int_0^{+\infty} \pi''_T \frac{dT}{T} \right. \\
 & \quad - \frac{\bar{\partial}\partial}{2i\pi} \left(\int_0^1 \Phi(\theta_T - \theta_0) \frac{dT}{T} + \int_1^{+\infty} \Phi(\theta_T - \theta_\infty) \frac{dT}{T} \right) \\
 & \quad - \frac{\bar{\partial}\partial}{2i\pi} \left(\int_0^1 \Phi(\theta_{0,T} - \theta_{0,0}) \frac{dT}{T} + \int_1^{+\infty} \Phi(\theta_{0,T} - \theta_{0,\infty}) \frac{dT}{T} \right) \\
 & \quad + C_0^W - D_0^V + \int_X (\dim X \operatorname{Td}(TX, g^{TX}) - \operatorname{Td}'(TX, g^{TX})) \operatorname{ch}(\xi, g^\xi) \\
 & \quad - \int_X \operatorname{Td}(TX, g^{TX}) \operatorname{ch}'(\xi, g^\xi) - \int_Y (\dim Y \operatorname{Td}(TY, g^{TY}) \\
 & \quad \left. - \operatorname{Td}'(TY, g^{TY})) \operatorname{ch}(\eta, g^\eta) \right\} \log(\varepsilon) \\
 & \rightarrow \Phi(\bar{\partial}\mu^3 + \partial\nu^3) - \frac{\bar{\partial}\partial}{i\pi} \Phi \lambda^3.
 \end{aligned}$$

6.8 Matching the divergences

$\alpha)$ $A \rightarrow +\infty$

Clearly $N_{\nabla}^X - N_{\mathbf{H}}$ defines the \mathbf{Z} -grading of $H(X, \xi|_X)$. Therefore for $T \geq 1$, it coincides with $P_T(N_{\nabla}^X - N_{\mathbf{H}})P_T$. In particular

$$(6.160) \quad \nabla_T^{H(X, \xi|_X)} P_T N_{\nabla}^X P_T = \nabla_T^{H(X, \xi|_X)} P_T N_{\mathbf{H}} P_T.$$

From (6.160), we get

$$(6.161) \quad \begin{aligned} & 2 \frac{\partial}{\partial b} \text{Tr}_s \left[P_T N_{\mathbf{H}} P_T \exp(-\nabla_T^{H(X, \xi|_X), 2} - b \nabla_T^{H(X, \xi|_X)'} P_T N_{\nabla}^X P_T) \right] \\ &= \partial \frac{\partial}{\partial b} \text{Tr}_s \left[P_T N_{\mathbf{H}} P_T \exp(-\nabla_T^{H(X, \xi|_X), 2} - b P_T N_{\mathbf{H}} P_T) \right]_{b=0}, \\ & 2 \frac{\partial}{\partial b} \text{Tr}_s \left[P_T N_{\mathbf{H}} P_T \exp(-\nabla_T^{H(X, \xi|_X), 2} + b \nabla_T^{H(X, \xi|_X)''} P_T N_{\nabla}^X P_T) \right]_{b=0} \\ &= -\bar{\partial} \frac{\partial}{\partial b} \text{Tr}_s \left[P_T N_{\mathbf{H}} P_T \exp(-\nabla_T^{H(X, \xi|_X), 2} - b P_T N_{\mathbf{H}} P_T) \right]_{b=0}. \end{aligned}$$

By (6.161), we obtain

$$(6.162) \quad \begin{aligned} & -\Phi 2\bar{\partial} \int_1^{T_0} \frac{\partial}{\partial b} \text{Tr}_s \left[P_T N_{\mathbf{H}} P_T \exp(-\nabla_T^{H(X, \xi|_X), 2} - b \nabla_T^{H(X, \xi|_X)'} P_T N_{\nabla}^X P_T) \right]_{b=0} \frac{dT}{T} \\ & -\Phi 2\partial \int_1^{T_0} \frac{\partial}{\partial b} \text{Tr}_s \left[P_T N_{\mathbf{H}} P_T \exp(-\nabla_T^{H(X, \xi|_X), 2} + b \nabla_T^{H(X, \xi|_X)''} P_T N_{\nabla}^X P_T) \right]_{b=0} \\ & + \frac{\bar{\partial}\partial}{i\pi} \Phi \int_1^{T_0} \frac{\partial}{\partial b} \text{Tr}_s \left[P_T N_{\mathbf{H}} P_T \exp(-\nabla_T^{H(X, \xi|_X), 2} - b P_T N_{\nabla}^X P_T) \right]_{b=0} \frac{dT}{T} \\ & = \frac{\bar{\partial}\partial}{2i\pi} \Phi \int_1^{T_0} \text{Tr}_s \left[(N_{\nabla}^X - N_{\mathbf{H}}) \exp(-\nabla_T^{H(X, \xi|_X), 2} - 2b \frac{P_T N_{\mathbf{H}} P_T}{T}) \right] \frac{dT}{T}. \end{aligned}$$

Using (6.48) and [5, Theorem 2.1], we find that the right-hand side of (6.162) is equal to

$$(6.163) \quad \begin{aligned} & -\Phi \text{Tr}_s \left[(N_{\nabla}^X - N_{\mathbf{H}}) \exp(-\nabla_{T_0}^{H(X, \xi|_X), 2}) \right] \\ & + \Phi \text{Tr}_s \left[(N_{\nabla}^X - N_{\mathbf{H}}) \exp(-\nabla^{H(X, \xi|_X), 2}) \right]. \end{aligned}$$

By (6.69), (6.88), (6.162), (6.163), we find that, as should be the case, as $A \rightarrow +\infty$, the divergences of both sides of (6.26) coincide. Therefore

$$(6.164) \quad \sum_{k=1}^4 I_k^1 = \Phi(\bar{\partial}\mu^1 + \partial\nu^1) - \frac{\bar{\partial}\partial}{i\pi} \Phi\lambda^1.$$

$\beta)$ $T_0 \rightarrow +\infty$

By (2.33),

$$(6.165) \quad \begin{aligned} \frac{\partial}{\partial b} \operatorname{Tr}_s \left[\exp(-B_{u^2}^{W,2} - bu \frac{\partial}{\partial u} B_{u^2}^{W'}) \right]_{b=0} &= -\partial \operatorname{Tr}_s \left[N_{u^2}^W \exp(-B_{u^2}^{W,2}) \right], \\ \frac{\partial}{\partial b} \operatorname{Tr}_s \left[\exp(-B_{u^2}^{W,2} - bu \frac{\partial}{\partial u} B_{u^2}^{W''}) \right]_{b=0} &= \bar{\partial} \operatorname{Tr}_s \left[N_{u^2}^W \exp(-B_{u^2}^{W,2}) \right]. \end{aligned}$$

Using (2.38), (2.39), (2.46), (2.51), (6.165), we find that the coefficient of $\log(T_0)$ in the left-hand side of (6.94) coincides with (6.70). So we get

$$(6.166) \quad \sum_{k=1}^4 I_k^2 = \Phi(\bar{\partial}\mu^2 + \partial\nu^2) - \frac{\bar{\partial}\partial}{i\pi} \Phi\lambda^2.$$

$\gamma)$ $\varepsilon \rightarrow +\infty$

Clearly, the coefficients of $\frac{1}{\varepsilon^2}$ in (6.71) and (6.159) coincide. For the coefficients of $\log(\varepsilon)$ in (6.72) and (6.159) to coincide, we should have the identity

$$(6.167) \quad \begin{aligned} \Phi\bar{\partial} \int_0^{+\infty} \pi'_T \frac{dT}{T} + \Phi\partial \int_0^{+\infty} \pi''_T \frac{dT}{T} - \\ \frac{\bar{\partial}\partial}{2i\pi} \left[\int_0^1 \Phi(\theta_T - \theta_0) \frac{dT}{T} + \int_1^{+\infty} \Phi(\theta_T - \theta_\infty) \frac{dT}{T} \right] \\ - \frac{\bar{\partial}\partial}{2i\pi} \left[\int_0^1 \Phi(\theta_{0,T} - \theta_{0,0}) \frac{dT}{T} + \int_1^{+\infty} \Phi(\theta_{0,T} - \theta_{0,\infty}) \frac{dT}{T} \right] = \\ \int_Y (\dim X \operatorname{Td}(TY, g^{TY}) - \operatorname{Td}'(TY, g^{TY}) \\ + \operatorname{Td}(TX, g^{TX})(\operatorname{Td}^{-1})'(N_{Y/X}, g^{N_{Y/X}})) \operatorname{ch}(\eta, g^\eta) \\ - \int_X (\dim X \operatorname{Td}(TX, g^{TX}) - \operatorname{Td}'(TX, g^{TX})) \operatorname{ch}(\xi, g^\xi). \end{aligned}$$

Now we give a direct proof of (6.167). By (3.34), (3.35), (6.76),

$$(6.168) \quad \begin{aligned} \frac{\bar{\partial}\partial}{2i\pi} \left[\int_0^1 (\theta_{0,T} - \theta_{0,0}) \frac{dT}{T} + \int_1^{+\infty} \Phi(\theta_{0,T} - \theta_{0,\infty}) \frac{dT}{T} \right] = \\ \int_X (\dim X \operatorname{Td}(TX, g^{TX}) - \operatorname{Td}'(TX, g^{TX})) \operatorname{ch}(\xi, g^\xi) \\ - \int_Y (\dim X \operatorname{Td}(TX, g^{TX}) - \operatorname{Td}'(TX, g^{TX})) \operatorname{Td}^{-1}(N_{Y/X}, g^{N_{Y/X}}) \operatorname{ch}(\eta, g^\eta). \end{aligned}$$

Also by Theorem 5.31,

$$\begin{aligned}
 (6.169) \quad & \Phi \bar{\partial} \int_0^{+\infty} \pi'_T \frac{dT}{T} + \Phi \partial \int_\theta^{+\infty} \pi''_T \frac{dT}{T} - \frac{\bar{\partial} \partial}{2i\pi} \left(\int_0^1 \Phi(\theta_T - \theta_0) \frac{dT}{T} \right. \\
 & \left. + \int_1^{+\infty} \Phi(\theta_T - \theta_\infty) \frac{dT}{T} \right) = \int_Y \left(\dim X(\text{Td}(TY, g^{TY}) - \text{Td}(TX, g^{TX}) \right. \\
 & \left. \text{Td}^{-1}(N_{Y/X}, g^{N_{Y/X}}) - \text{Td}'(TY, g^{TY}) + \text{Td}'(TX, g^{TX}) \text{Td}^{-1}(N_{Y/X}, g^{N_{Y/X}}) \right. \\
 & \left. + \text{Td}(TX, g^{TX})(\text{Td}^{-1})'(N_{Y/X}, g^{N_{Y/X}}) \right) \text{ch}(\eta, g^\eta).
 \end{aligned}$$

Then (6.167) follows from (6.168), (6.169).

Thus we find that there are explicit universal forms μ^3, ν^3, λ^3 such that

$$(6.170) \quad \sum_{k=1}^4 I_k^3 = \Phi(\bar{\partial}\mu^3 + \partial\nu^3) - \frac{\bar{\partial}\partial}{i\pi} \Phi\lambda^3.$$

6.9 An identity on Bott-Chern classes and Bott-Chern currents

Recall that $\widehat{A}(x) = \frac{x/2}{\sinh(x/2)}$. We identify $(\widehat{A}'/\widehat{A})(x)$ with the corresponding additive genus.

Theorem 6.22 — *The following identity holds,*

$$\begin{aligned}
 (6.171) \quad & \widetilde{\text{ch}} \left(H^{(Y, \eta|_Y)}, g^{H(X, \xi|_X)}, g^{H(Y, \eta|_Y)} \right) \\
 & - T(\omega^W, g^\eta) + T(\omega^V, g^\xi) \\
 & = \int_X \text{Td}(TX, g^{TX}) T(\xi, g^\xi) + \int_Y \mathbf{B}(TY, TX|_W, g^{TX|_W}) \text{ch}(\eta, g^\eta) \\
 & - \Gamma'(1) \int_Y \text{Td}(TY) \frac{\widehat{A}'}{\widehat{A}}(N_{Y/X}) \text{ch}(\eta) \text{ in } P^S/P^{S,0}.
 \end{aligned}$$

Proof. Using Theorems 6.11-6.14 and (6.170), we obtain the equality,

$$\begin{aligned}
 (6.172) \quad & \tilde{\text{ch}} \left(H(Y, \eta|_Y), g^{H(X, \xi|_X)}, g^{H(Y, \eta|_Y)} \right) \\
 & - T(\omega^W, g^\eta) + T(\omega^V, g^\xi) - \int_X \text{Td}(TX, g^{TX}) T(\xi, g^\xi) \\
 & - \int_Y \mathbf{B}(TY, TX|_W, g^{TX|_W}) \text{ch}(\eta, g^\eta) \\
 & + \Gamma'(1) \left\{ C_0^W - \Phi \text{Tr}_s \left[N_{\mathbf{V}}^Y \exp(-\nabla^{H(Y, \eta|_Y), 2}) \right] \right. \\
 & - D_0^V + \Phi \text{Tr}_s \left[(N_{\mathbf{V}}^X - N_{\mathbf{H}}) \exp(-\nabla^{H(X, \xi|_X), 2}) \right] \\
 & \left. - \int_X \text{Td}(TX, g^{TX}) \text{ch}'(\xi, g^\xi) + \frac{1}{2} \dim N_{Y/X} \right. \\
 & \left. \int_Y \text{Td}(TY, g^{TY}) \text{ch}(\eta, g^\eta) \right\} \in P^{S,0}.
 \end{aligned}$$

By Theorem 3.3 and by [20], [13, Theorem 1.27], it is clear that

$$\begin{aligned}
 (6.173) \quad & \Phi \left(\text{Tr}_s \left[(N_{\mathbf{V}}^X - N_{\mathbf{H}}) \exp(-\nabla^{H(X, \xi|_X), 2}) \right] \right. \\
 & \left. - \text{Tr}_s \left[N_{\mathbf{V}}^Y \exp(-\nabla^{H(Y, \eta|_Y), 2}) \right] \right) \in P^{S,0}.
 \end{aligned}$$

Using (6.154), (6.173) and proceeding as in [19, p. 72], we get (6.171). \square

6.10 Proof of Theorem 6.2

By Theorem 5.17 and by (5.30), we get

$$\begin{aligned}
 (6.174) \quad & \mathbf{B}(TY, TX|_W, g^{TX|_W}) = -\text{Td}^{-1}(N_{Y/X}, g^{N_{Y/X}}) \widetilde{\text{Td}}(TY, TX|_W, g^{TX|_W}) \\
 & + \text{Td}(TY) \left(R + \Gamma'(1) \frac{\widehat{A}'}{\widehat{A}} \right) (N_{Y/X}) \text{ in } P^W/P^{W,0}.
 \end{aligned}$$

From Theorem 6.22 and from (6.174), we get the first equality in (6.6). Using (3.35), we see that

$$\begin{aligned}
 (6.175) \quad & \int_X \text{Td}(TX) R(TX) \text{ch}(\xi) - \int_Y \text{Td}(TY) R(TY) \text{ch}(\eta) = \\
 & \int_Y \text{Td}(TY) R(N_{Y/X}) \text{ch}(\eta) \text{ in } P^S/P^{S,0}.
 \end{aligned}$$

By (6.175), we thus obtain the second equality in (6.6). The proof of Theorem 6.2 is completed. \square

7. A new horizontal bundle on V and the conjugate superconnection $\tilde{A}_{u,T}$

In general $T^H V|_W \neq T^H W$. This is a potential source of difficulties. In effect, by [19, Section 9 and Section 13], we know that as $T \rightarrow +\infty$, in one given fibre X , the heat kernel of $\exp(-u(D^X + TV)^2)$ evaluated on the diagonal concentrates on Y like a gaussian. Here we have a family of such fibres X . Implicitly, our study involves the variation of the concentration of the heat kernel of $\exp(-u(D^X + TV)^2)$ along the fibres X_s when $s \in S$ varies infinitesimally. The connection ∇^E , which provides a local trivialization of E near a given $s \in S$, is not adequate for such a study, because since in general $T^H V|_W \neq T^H W$, the fibres Y are not preserved by this trivialization. Thus, we are forced to modify the horizontal bundle $T^H V$ near W .

In this Chapter, we construct an extension of $T^H W$ to a horizontal subbundle of TV , which coincides with $T^H V$ away from a neighborhood of W in V . Then by conjugating the superconnection $A_{u,T}$, we obtain a new superconnection $\tilde{A}_{u,T}$, in which the annoying term $f^\alpha \nabla_{f_\alpha^{H,V}}^{\Lambda(T^{*(0,1)}X)} \otimes \xi$ is replaced by $f^\alpha \nabla_{f_\alpha^{H,W}}^{\Lambda(T^{*(0,1)}X)} \otimes \xi$.

Still, once this difficulty is eliminated, a new one appears. In fact, in Chapter 13, we also need to use local index theoretic techniques in a situation where $u \rightarrow 0$, $T \rightarrow +\infty$. This forces us to determine $T^H W$ more rigidly than described before. In effect the jet of order 1 of $T^H W$ in directions normal to the fibres Y is also important.

This Chapter is organized as follows. In Section 7.1, we recall the expression of D^X and D^Y as Dirac operators [29]. In Section 7.2, we describe the exact sequence $0 \rightarrow TY \rightarrow TX|_W \rightarrow N_{Y/X} \rightarrow 0$. In Section 7.3, we obtain a global coordinate system on a neighborhood of W in V . In Section 7.4, we recall the construction in [5] of a splitting $\xi = \xi^+ \oplus \xi^-$ near W . In Section 7.5, we give a cohomological obstruction to the identity $T^H V|_W = T^H W$. In Section 7.6, we construct an extension of $T^H W$ to V . In Section 7.7, the conjugate superconnection $\tilde{A}_{u,T}$ is introduced. Finally in Section 7.8, we give generalized Lichnerowicz's formulas for $A_{u,T}^2$ and $\tilde{A}_{u,T}^2$.

In this Chapter, the assumptions and notation of Chapters 3, 4 and 6 are in force.

7.1 A formula for D^X and D^Y

As explained in Chapter 6, to avoid notational difficulties, we suppose that V , W and S are compact.

We use the notation of Section 2.2. If $U \in T_{\mathbf{R}}X$ (resp. $T_{\mathbf{R}}Y$), the Clifford operator $c(U)$ acts naturally on $\Lambda(T^{*(0,1)}X) \widehat{\otimes} \xi$ (resp. on $\Lambda(T^{*(0,1)}Y) \otimes \eta$).

Let $\nabla^{\Lambda(T^{*(0,1)}X) \widehat{\otimes} \xi}$ (resp. $\nabla^{\Lambda(T^{*(0,1)}Y) \otimes \eta}$) be the connection on $\Lambda(T^{*(0,1)}X) \widehat{\otimes} \xi$ (resp. $\Lambda(T^{*(0,1)}Y) \otimes \eta$) induced by ∇^{TX} and ∇^ξ (resp. by ∇^{TY} and ∇^η). Recall that

$$(7.1) \quad D^X = \bar{\partial}^X + \bar{\partial}^{X*}, \quad D^Y = \bar{\partial}^Y + \bar{\partial}^{Y*}.$$

Proposition 7.1 — *Let $e_1, \dots, e_{2\ell}$ (resp. $e'_1, \dots, e'_{2\ell'}$) be an orthonormal basis of $T_{\mathbf{R}}X$ (res. $T_{\mathbf{R}}Y$). Then*

$$(7.2) \quad \begin{aligned} D^X &= \sum_1^{2\ell} \frac{c(e_i)}{\sqrt{2}} \nabla_{e_i}^{\Lambda(T^{*(0,1)}X) \widehat{\otimes} \xi}, \\ (\text{resp. } D^Y &= \sum_1^{2\ell'} \frac{c(e'_i)}{\sqrt{2}} \nabla_{e'_i}^{\Lambda(T^{*(0,1)}Y) \otimes \eta}). \end{aligned}$$

Proof. Since the metrics g^{TX} and g^{TY} are fibrewise Kähler, our Proposition is a result of Hitchin [29, p. 13], [19, Proposition 8.5]. \square

7.2 The canonical exact sequence on W

We now consider the exact sequence of holomorphic Hermitian vector bundles on W

$$(7.3) \quad 0 \rightarrow TY \rightarrow TX|_W \rightarrow N_{Y/X} \rightarrow 0.$$

Recall that $N_{Y/X}$ is identified to the orthogonal bundle to TY in $TX|_W$.

Let P^{TY} , $P^{N_{Y/X}}$ be the orthogonal projection operators from $TX|_W$ on TY , $N_{Y/X}$. Let $\nabla^{N_{Y/X}}$ be the holomorphic Hermitian connection on $(N_{Y/X}, g^{N_{Y/X}})$.

Proposition 7.2 — *The following identities hold*

$$(7.4) \quad \begin{aligned} \nabla^{TY} &= P^{TY} \nabla^{TX|_W}, \\ \nabla^{N_{Y/X}} &= P^{N_{Y/X}} \nabla^{TX|_W}. \end{aligned}$$

Proof. This result follows from (5.11). \square

Definition 7.3. Let ${}^0\nabla^{TX|_W}$ be the connection on $TX|_W = TY \oplus N_{Y/X}$,

$$(7.5) \quad {}^0\nabla^{TX|_W} = \nabla^{TY} \oplus \nabla^{N_{Y/X}}.$$

Set

$$(7.6) \quad A = \nabla^{TX}|_W - {}^0\nabla^{TX}|_W.$$

Then A is a 1-form on W with values in skew-adjoint endomorphisms of $TX|_W$ which exchange TY and $N_{Y/X}$. Since ∇^{TX} is fibrewise torsion free, if $U, V \in T_{\mathbf{R}}Y$

$$(7.7) \quad A(U)V - A(V)U = 0.$$

Definition 7.4. If $e_1, \dots, e_{2\ell'}$ is an orthonormal basis of $T_{\mathbf{R}}Y$, set

$$(7.8) \quad \nu = \frac{1}{2\ell'} \sum_1^{2\ell'} A(e_i)e_i.$$

Then ν is a section of $N_{Y/X, \mathbf{R}}$. It is called the mean curvature of the fibre Y .

7.3 A coordinate system on V near W

If $y \in W$, $Z \in N_{Y/X, \mathbf{R}, y}$, let $t \in \mathbf{R} \rightarrow x_t = \exp_y^X(tZ) \in W$ be the geodesic in the fibre $X_{\pi_W y}$ with respect to g^{TX} , such that $x_0 = y$, $\frac{dx}{dt} \Big|_{t=0} = Z$.

For $0 < \varepsilon < +\infty$, set

$$(7.9) \quad B_\varepsilon = \{Z \in N_{Y/X, \mathbf{R}}, |Z| < \varepsilon\}.$$

For $\varepsilon_0 > 0$ small enough, the map $(y, Z) \in N_{Y/X, \mathbf{R}} \rightarrow \exp_y^X Z \in W$ is a diffeomorphism from $B_{2\varepsilon_0}$ on a tubular neighborhood $\mathcal{U}_{2\varepsilon_0}$ of W in V . From now on, we use the notation $x = (y, Z)$ instead of $x = \exp_y^X(Z)$. We identify $y \in W$ with $(y, 0) \in N_{Y/X, \mathbf{R}}$.

Recall that dv_X, dv_Y are the volume elements of the fibres X, Y with respect to g^{TX}, g^{TY} . Let $dv_{N_{Y/X}}$ be the volume element of $N_{Y/X, \mathbf{R}}$ with respect to $g^{N_{Y/X}}$. Let $k(y, Z)$ be the smooth positive function on B_{ε_0} such that

$$(7.10) \quad dv_X(y, Z) = k(y, Z)dv_Y(y)dv_{N_{Y/X}}(Z).$$

The function $k(y, Z)$ has a positive lower bound on $\mathcal{U}_{\varepsilon_0}$. Also

$$(7.11) \quad k = 1 \quad \text{on } W.$$

7.4 A splitting of ξ near W

We use the identification (3.29), so that $H(\xi, v)$ is considered as a subbundle of $\xi|_W$. Let $H^\perp(\xi, v)$ be the orthogonal bundle to $H(\xi, v)$ in $\xi|_W$. Now we recall the construction in [5, Section 3f)] of a splitting $\xi = \xi^+ \oplus \xi^-$ near W which extends the splitting $\xi|_W = H(\xi, v) \oplus H^\perp(\xi, v)$.

We have the identity

$$(7.12) \quad H(\xi, v) = \{f \in \xi|_W ; V^2 f = 0\} .$$

For $y \in W$, let $\mu(y)$ be the smallest nonzero eigenvalue of the self-adjoint operator $V^2(y)$. Since $H(\xi, v)$ is smooth vector bundle, the function $\mu: W \rightarrow \mathbf{R}_+^*$ is continuous. Since W is compact, the function μ has a positive lower bound $2b$ on W .

We may and we will assume that $\varepsilon_0 > 0$ is small enough so that if $x \in \mathcal{U}_{2\varepsilon_0}$, b is not an eigenvalue $V^2(x)$.

Definition 7.5. For $0 \leq k \leq m$, $x \in \mathcal{U}_{\varepsilon_0}$, $\xi_{k,x}^-$ (resp. $\xi_{k,x}^+$) denotes the direct sum of the eigenspaces of the restriction of $V^2(x)$ to $\xi_{k,x}$ corresponding to eigenvalues which are smaller (resp. larger) than b .

For $0 \leq k \leq m$, the $\xi_{k,x}^\pm$ are the fibres of smooth vector subbundles ξ_k^\pm of ξ_k over $\mathcal{U}_{\varepsilon_0}$. Clearly on $\mathcal{U}_{\varepsilon_0}$, for $0 \leq k \leq m$,

$$(7.13) \quad \xi_k = \xi_k^+ \oplus \xi_k^- .$$

Set

$$(7.14) \quad \xi^\pm = \bigoplus_{k=0}^m \xi_k^\pm , \quad \xi_+^\pm = \bigoplus_{k \text{ even}} \xi_k^\pm , \quad \xi_-^\pm = \bigoplus_{k \text{ odd}} \xi_k^\pm .$$

In (7.13), (7.14), the various splittings are orthogonal. We equip ξ^\pm with the metric g^{ξ^\pm} induced by g^ξ .

Then v, v^* preserve ξ^+, ξ^- . Let V^\pm be the restriction of V to ξ^\pm . We will often write V in matrix form with respect to the splitting $\xi = \xi^+ \oplus \xi^-$,

$$(7.15) \quad V = \begin{bmatrix} V^+ & 0 \\ 0 & V^- \end{bmatrix} .$$

By (7.12),

$$(7.16) \quad \xi^-|_W = H(\xi, v) = \ker V|_W .$$

From (3.28), (7.12), we get

$$(7.17) \quad \xi^-|_W = \Lambda N_{Y/X}^* \otimes \eta .$$

Let P^{ξ^\pm} be the orthogonal projection operators from ξ on ξ^\pm . Let $\tilde{\nabla}^{\xi^\pm}$ be the Hermitian connection on ξ^\pm , $\tilde{\nabla}^{\xi^\pm} = P^{\xi^\pm} \nabla^\xi$.

Now we recall result of [5, Proposition 1.8].

Proposition 7.6 — *The connection $i^* \tilde{\nabla}^{\xi^-}$ on $\xi^-|_W = H(\xi, v)$ is exactly the holomorphic Hermitian connection on $(H(\xi, v), g^{H(\xi, v)})$.*

Definition 7.7. Let $\tilde{\nabla}^\xi$ be the connection on $\xi|_{\mathcal{U}_{\varepsilon_0}} = \xi^+ \oplus \xi^-$,

$$(7.18) \quad \tilde{\nabla}^\xi = \tilde{\nabla}^{\xi^+} \oplus \tilde{\nabla}^{\xi^-}.$$

Set

$$(7.19) \quad B = \nabla^\xi - \tilde{\nabla}^\xi.$$

Then the connection $\tilde{\nabla}^\xi$ preserves the metric g^ξ , and B is a 1-form on $\mathcal{U}_{\varepsilon_0}$ which takes values in skew-adjoint endomorphisms of ξ which exchange ξ^+ and ξ^- .

By Section 2.2, if $Z \in N_{Y/X, \mathbf{R}}$, $\hat{c}(Z)$ acts on $\Lambda(N_{Y/X}^*) \otimes \eta$.

Proposition 7.8 — *If $y \in W$, $Z \in N_{Y/X, \mathbf{R}, y}$ then*

$$(7.20) \quad \tilde{\nabla}_Z^\xi V^-(y) = \frac{\sqrt{-1}}{\sqrt{2}} \hat{c}(Z).$$

Proof. Taking into account the discrepancy in the notation of [19, Section 5 a)] and our Section 2.2, our Proposition is just [19, Proposition 8.13]. \square

Remark 7.9. Clearly

$$(7.21) \quad \nabla_Z^\xi V = \tilde{\nabla}_Z^\xi V + [B(Z), V].$$

Since $\xi^-|_W = \ker V|_W$, $\xi^+|_V = \text{Im } V|_W$, we deduce from (7.21) that

$$(7.22) \quad P^{\xi^-} \nabla_Z^\xi V P^{\xi^-}|_W = P^{\xi^-} \tilde{\nabla}_Z^\xi V P^{\xi^-}|_W.$$

7.5 A cohomological obstruction to the equality $T^H V|_W = T^H W$

Let ρ be the restriction map $H^1(V, T^*V) \rightarrow H^1(W, T^*V|_W) \rightarrow H^1(W, T^*X|_W)$. If $\alpha \in H^1(V, T^*V)$, $(\rho\alpha)^{\dim Y+1} \in H^{\dim Y+1}(W, \Lambda^{\dim Y+1}(T^*X|_W))$.

Clearly $T^H V|_W = T^H W$ if and only if $T^H W$ and $TX|_W$ are orthogonal with respect to $\omega|_W^V$.

Let $[\omega^V]$ be the class of ω^V in $H^1(V, T^*V)$. Then if $T^H V|_W = T^H W$,

$$(7.23) \quad (\rho[\omega^V])^{\dim Y+1} = 0 \text{ in } H^{\dim Y+1}(W, \Lambda^{\dim Y+1}(T^*X|_W)).$$

Then (7.23) provides us with a cohomological obstruction to the equality $T^H V|_W = T^H W$. In particular if V, W are compact and Kähler and if $H^1(V, T^*V)$ is one dimensional, the class $[\omega^V]$ is nonzero and fixed up to a constant. If (7.23) does not hold, we cannot find ω^V such that $T^H V|_W = T^H W$.

This is in dramatic contrast with the situation one meets in the C^∞ category, when trying, say, to establish a formula similar to Theorem 0.1 for the $\tilde{\eta}$ forms of Bismut-Cheeger [12]. In this context, one can always assume that $T_{\mathbf{R}}^H V|_W = T_{\mathbf{R}}^H W$. One does not need to proceed the way we do in the present paper for the $\tilde{\eta}$ forms, essentially because the image of $K(S) \otimes_{\mathbf{Q}} \mathbf{Z}$ by the Chern character map spans $H^{\text{even}}(S, \mathbf{Q})$.

7.6 An extension of $T^H W$ to V

Up to now, $T^H W$ is a subbundle of TW . It will be important to extend $T^H W$ to a subbundle of TV on V .

Let $\nabla^{\pi^* \check{\nu}^{TS}}$ be the trivial connection on $\pi^* TS$ along the fibres X . We equip $TV = T^H V \oplus TX$ with the connection along the fibres X ,

$$(7.24) \quad \nabla^{TV} = \nabla^{\pi^* \check{\nu}^{TS}} \oplus \nabla^{TX}.$$

Observe that our notation fits with (1.3).

Definition 7.10. If $(y, Z) \in N_{Y/X, \mathbf{R}}$, if $A \in T_{\mathbf{R}} S$, let $A' \in T_{\mathbf{R}} V$ be the solution of the differential equation along $t \in \mathbf{R} \rightarrow x_t = \exp_y^X(tZ)$,

$$(7.25) \quad \begin{aligned} \nabla_{\frac{dx}{dt}}^{TV} A' + T_{x_t}^V \left(A', \frac{dx}{dt} \right) &= 0, \\ A'_0 &= A^{H, W}. \end{aligned}$$

Since $TV = T^H V \oplus TX$, we can write A' in the form

$$(7.26) \quad A' = A'^{H, V} + A'^{TX}, \quad A'^{H, V} \in T_{\mathbf{R}}^H V, \quad A'^{TX} \in T_{\mathbf{R}} X.$$

Theorem 7.11 — *The following identities hold,*

$$(7.27) \quad \begin{aligned} A'^{H, V} &= A^{H, V}, \\ \nabla_{\frac{dx}{dt}}^{TX} A'^{TX} + T_{x_t}^V \left(A'^{H, V}, \frac{dx}{dt} \right) &= 0, \\ A_0'^{TX} &= A^{H, N_{Y/X}}. \end{aligned}$$

Moreover the map $A \in T_{\mathbf{R}} S \rightarrow A'_t \in (T_{\mathbf{R}} V)_{x_t}$ is a complex map.

Proof. By Section 1.1, $T(A'^{TX}, \frac{dx}{dt}) = 0$, and so

$$(7.28) \quad \nabla_{\frac{dx}{dt}}^{TV} A' + T_{x_t}^V \left(A'^{H, V}, \frac{dx}{dt} \right) = 0.$$

Since $T_{x_t}^V(A'^{H, V}, \frac{dx}{dt}) \in T_{\mathbf{R}} X$, we get (7.27).

By Section 2.1, T^V is a $(1, 1)$ -form, and moreover if $U \in T^H V$, $V \in \overline{TX}$ (resp. $U \in \overline{THV}$, $V \in TX$), then $T^V(U, V) \in TX$ (resp. \overline{TX}). From (7.26), we find that if $A \in TS$, then $A'^{TX} \in TV$, and that if $A \in \overline{TS}$, then $A'^{TX} \in \overline{TV}$, i.e. the map $A \in T_{\mathbf{R}} S \rightarrow A'_t \in (T_{\mathbf{R}} V)_{x_t}$ is complex. \square

Using the identification $(y, Z) \simeq \exp_y^X(Z)$, if $A \in TS$, $(y, Z) \in \mathcal{U}_{\varepsilon_0}$, we can define the corresponding $A'_{(y, Z)} \in TV$.

Let $\gamma: \mathbf{R} \rightarrow [0, 1]$ be a smooth function such that

$$(7.29) \quad \begin{aligned} \gamma(a) &= 1 \text{ for } a \leq 1/2, \\ &0 \text{ for } a \geq 1. \end{aligned}$$

Then $\gamma\left(\frac{|Z|}{\varepsilon_0}\right)$ can be considered as a C^∞ function on V with values in $[0, 1]$, which vanishes on $V \setminus \mathcal{U}_{\varepsilon_0}$.

Definition 7.12. If $A \in TS$, set

$$(7.30) \quad A^{H,W} = \gamma\left(\frac{|Z|}{\varepsilon_0}\right) A' + \left(1 - \gamma\left(\frac{|Z|}{\varepsilon_0}\right)\right) A^{H,V}.$$

By Theorem 7.11, $A^{H,W} \in TV$, and

$$(7.31) \quad \pi_{V*} A^{H,W} = A.$$

Definition 7.13. Let $T^H W$ be the smooth subbundle of TV which is the image of TS by the map $A \rightarrow A^{H,W}$.

Using (7.25), it is clear that $T^H W$ extends the given vector bundle $T^H W$ on W to the whole V .

Definition 7.14. If $A \in TS$, set

$$(7.32) \quad A^{H,N_{Y/X}} = A^{H,W} - A^{H,V}.$$

By (7.31), $A^{H,N_{Y/X}} \in TX$. Again, our definition of $A^{H,N_{Y/X}}$ extends to V our initial construction of $A^{H,N_{Y/X}}$ given in Definition 1.8, which was only valid on W .

Remark 7.15. It is natural to ask why we did not use, instead of (7.25), the simpler equation

$$(7.33) \quad \nabla_{\frac{d\bar{z}}{dt}}^{TV} A' = 0.$$

In effect we could use as well equation (7.33) instead of (7.25) in Chapters 8-11 but not in Chapters 12-13.

Equation (7.24) should have a clear interpretation. In effect if g^{TS} is an arbitrary metric on TS whose Kähler form is ω^S , for $\varepsilon > 0$ small enough, $\omega^V + \frac{1}{\varepsilon}\pi^*\omega^S$ is the Kähler form of a metric g_ε^{TV} on TV . Let ∇_ε^{TV} be the holomorphic Hermitian connection on (TV, g_ε^{TV}) . Then one verifies easily that as $\varepsilon \rightarrow 0$, the connection ∇_ε^{TV} tends to a connection ∇_0^{TV} on TV . Using (2.10), equation (7.25) is equivalent to

$$(7.34) \quad \nabla_{0, \frac{d\bar{z}}{dt}}^{TV} A' = 0.$$

Of course, we can replace everywhere the holomorphic Hermitian connections by the corresponding Levi-Civita connections. Equation (7.34) is a way of encoding the Levi-Civita connection in the ‘‘adiabatic limit’’ process where $\varepsilon \rightarrow 0$, which, as we know by [4], [12], [11] is crucial in understanding the local families index constructions of [4].

7.7 The conjugate superconnection $\tilde{A}_{u,T}$

Let f_1, \dots, f_m be a locally defined smooth basis of $T_{\mathbf{R}}S$, and let f^1, \dots, f^m be the corresponding dual basis of $T_{\mathbf{R}}^*S$. Let $e_1, \dots, e_{2\ell}$ be an orthonormal basis of $T_{\mathbf{R}}X$.

Definition 7.16. For $u > 0, T > 0$, set

$$(7.35) \quad \begin{aligned} \tilde{A}_{u,T} &= \exp \left\{ -f^\alpha \frac{c}{\sqrt{2u}} \left(f_\alpha^{H, N_{Y/X}} \right) \right\} \\ &\quad A_{u,T} \exp \left\{ f^\alpha \frac{c}{\sqrt{2u}} \left(f_\alpha^{H, N_{Y/X}} \right) \right\}, \\ \tilde{N}_{u^2}^V &= \exp \left\{ -f^\alpha \frac{c}{\sqrt{2u}} \left(f_\alpha^{H, N_{Y/X}} \right) \right\} \\ &\quad N_{u^2}^V \exp \left\{ f^\alpha \frac{c}{\sqrt{2u}} \left(f_\alpha^{H, N_{Y/X}} \right) \right\}. \end{aligned}$$

Clearly $\tilde{A}_{u,T}$ is a superconnection on E . Also the expression in (7.35) does not depend on the local basis f_1, \dots, f_m . For convenience, we assume that f_1, \dots, f_m are such that

$$(7.36) \quad [f_\alpha, f_\beta] = 0.$$

In particular the forms f^1, \dots, f^m are closed.

Theorem 7.17 — For $u > 0, T > 0$, the following identity hold

$$(7.37) \quad \begin{aligned} \tilde{A}_{u,T} &= uD^X + TV + f^\alpha \wedge \left(\nabla_{f_\alpha^{H,W}}^{\Lambda(T^{*(0,1)}X) \otimes \xi} - \frac{1}{2}c(e_i)c(\nabla_{e_i}^{TX} f_\alpha^{H, N_{Y/X}}) \right) \\ &\quad + \frac{1}{2}f^\alpha f^\beta \left(-\frac{1}{2} \left\langle T^V(f_\alpha^{H,V}, f_\beta^{H,V}), e_i \right\rangle - \left\langle f_\alpha^{H, N_{Y/X}}, \nabla_{e_i}^{TX} f_\beta^{H, N_{Y/X}} \right\rangle \right) \\ &\quad + 2 \left\langle \nabla_{f_\alpha^{H,W}}^{TX} f_\beta^{H, N_{Y/X}}, e_i \right\rangle \frac{c(e_i)}{\sqrt{2u}} \\ &\quad - \frac{f^\alpha f^\beta f^\gamma}{2u^2} \left(\left\langle f_\beta^{H, N_{Y/X}}, \nabla_{f_\alpha^{H,W}}^{TX} f_\gamma^{H, N_{Y/X}} \right\rangle \right. \\ &\quad \left. + \frac{1}{2} \left\langle f_\alpha^{H, N_{Y/X}}, T^V(f_\beta^{H,V}, f_\gamma^{H,V}) \right\rangle \right), \\ \tilde{N}_{u^2}^V &= N_{u^2}^X + i\omega^V(e_i, f_\alpha^{H,W}) \frac{c(e_i)}{u\sqrt{2}} f^\alpha \\ &\quad + \frac{i}{2u^2} \omega^V(f_\alpha^{H,W}, f_\beta^{H,W}) f^\alpha f^\beta. \end{aligned}$$

Proof. By (2.31), (4.1), (7.2) and by [14, Proposition 2.4],

$$(7.38) \quad \begin{aligned} A_{u,T} &= u \frac{c(e_i)}{\sqrt{2}} \nabla_{e_i}^{\Lambda(T^{*(0,1)}X)} \widehat{\otimes} \xi + TV \\ &\quad + f^\alpha \nabla_{f_\alpha^{H,V}}^{\Lambda(T^{*(0,1)}X)} \widehat{\otimes} \xi - \frac{c(T^V)}{2\sqrt{2}u}, \\ N_V^V &= \frac{i}{4} \omega^V(e_i, e_j) c(e_i) c(e_j) + \frac{\dim X}{2}. \end{aligned}$$

Clearly, if $U \in T_{\mathbf{R}}X$,

$$(7.39) \quad [f^\alpha c(f_\alpha^{H,N_{Y/X}}), c(U)] = -2 \langle f_\alpha^{H,N_{Y/X}}, U \rangle f^\alpha.$$

From (7.39), we deduce that

$$(7.40) \quad e^{-f^\alpha \frac{c(f_\alpha^{H,N_{Y/X}})}{\sqrt{2}u}} c(U) e^{f^\alpha \frac{c(f_\alpha^{H,N_{Y/X}})}{\sqrt{2}u}} = c(U) + \frac{\sqrt{2}}{u} f^\alpha \langle f_\alpha^{H,N_{Y/X}}, U \rangle.$$

Let $\nabla^{T_{\mathbf{R}}S}$ be the locally defined flat connection on $T_{\mathbf{R}}S$, such that $\nabla^{T_{\mathbf{R}}S} f_\alpha = 0$. In the sequel, we implicitly differentiate tensors in the f_α 's with respect to $\nabla^{T_{\mathbf{R}}S}$.

If $U' \in T_{\mathbf{R}}V$,

$$(7.41) \quad [f^\alpha c(f_\alpha^{H,N_{Y/X}}), \nabla_{U'}^{\Lambda(T^{*(0,1)}X)} \widehat{\otimes} \xi] = -f^\alpha c(\nabla_{U'}^{TX} f_\alpha^{H,N_{Y/X}}),$$

and so

$$(7.42) \quad \begin{aligned} [f^\beta c(f_\beta^{H,N_{Y/X}}), [f^\alpha c(f_\alpha^{H,N_{Y/X}}), \nabla_{U'}^{\Lambda(T^{*(0,1)}X)} \widehat{\otimes} \xi]] \\ = -2 f^\alpha f^\beta \langle f_\alpha^{H,N_{Y/X}}, \nabla_{U'}^{TX} f_\beta^{H,N_{Y/X}} \rangle. \end{aligned}$$

Of course, the higher order commutators vanish. From (7.41), (7.42), we get

$$(7.43) \quad \begin{aligned} e^{-f^\alpha \frac{c(f_\alpha^{H,N_{Y/X}})}{\sqrt{2}u}} \nabla_{U'}^{\Lambda(T^{*(0,1)}X)} \widehat{\otimes} \xi e^{f^\alpha \frac{c(f_\alpha^{H,N_{Y/X}})}{\sqrt{2}u}} = \\ \nabla_{U'}^{\Lambda(T^{*(0,1)}X)} \widehat{\otimes} \xi + f^\alpha \frac{c}{\sqrt{2}u} (\nabla_{U'}^{TX} f_\alpha^{H,N_{Y/X}}) \\ - \frac{1}{2} \frac{f^\alpha f^\beta}{u^2} \langle f_\alpha^{H,N_{Y/X}}, \nabla_{U'}^{TX} f_\beta^{H,N_{Y/X}} \rangle. \end{aligned}$$

Finally

$$(7.44) \quad \begin{aligned} \omega^V(e_i, f_\alpha^{H,N_{Y/X}}) &= \omega^V(e_i, f_\alpha^{H,W}), \\ \omega^V(f_\alpha^{H,W}, f_\beta^{H,W}) &= \omega^V(f_\alpha^{H,V}, f_\beta^{H,V}) + \omega^V(f_\alpha^{H,N_{Y/X}}, f_\beta^{H,N_{Y/X}}). \end{aligned}$$

From (7.38), (7.40), (7.43), (7.44), we get (7.37). The proof of our Theorem is completed. \square

Remark 7.18. The most remarkable feature of (7.37) is that $f^\alpha \wedge \nabla_{f_\alpha^{H,V}}^{\Lambda(T^{*(0,1)}X)} \widehat{\otimes} \xi$ has been replaced by $f^\alpha \wedge \nabla_{f_\alpha^{H,W}}^{\Lambda(T^{*(0,1)}X)} \widehat{\otimes} \xi$. Of course $f_\alpha^{H,W}|_W \in T_{\mathbf{R}}^H W$.

7.8 A Lichnerowicz formula for $A_{u,T}^2$ and $\tilde{A}_{u,T}^2$

Set

$$(7.45) \quad R'^{\xi} = R^{\xi} + \frac{1}{2} \text{Tr}[R^{TX}].$$

Let K be the scalar curvature of the fibres (X, g^{TX}) . Let f^1, \dots, f^m be a basis of $T_{\mathbf{R}}S$, let f^1, \dots, f^m be the corresponding dual basis. Let $e_1, \dots, e_{2\ell}$ be a locally defined smooth orthonormal base of $T_{\mathbf{R}}X$.

If C is a smooth section of $T_{\mathbf{R}}^*X \otimes \text{End}(\pi_V^* \Lambda(T_{\mathbf{R}}^*S) \hat{\otimes} \Lambda(T^{*(0,1)}X) \hat{\otimes} \xi)$, put

$$(7.46) \quad \left(\nabla_{e_i}^{\Lambda(T^{*(0,1)}X) \hat{\otimes} \xi} + C(e_i) \right)^2 = \sum_1^{2\ell} \left(\nabla_{e_i}^{\Lambda(T^{*(0,1)}X) \hat{\otimes} \xi} + C(e_i) \right)^2 - \nabla_{\sum_1^{2\ell} \nabla_{e_i}^{TX} e_i}^{\Lambda(T^{*(0,1)}X) \hat{\otimes} \xi} - C\left(\sum_1^{2\ell} \nabla_{e_i}^{TX} e_i\right).$$

Then the operator (7.46) does not depend on the choice of the basis $e_1, \dots, e_{2\ell}$.

Theorem 7.19 — For $u > 0$, $T > 0$, the following identity holds

$$(7.47) \quad A_{u,T}^2 = \frac{-u^2}{2} \left(\nabla_{e_i}^{\Lambda(T^{*(0,1)}X) \hat{\otimes} \xi} + \frac{1}{2} \langle S^V(e_i) e_j, f_{\alpha}^{H,V} \rangle \right. \\ \left. \sqrt{2} \frac{c(e_j)}{u} f^{\alpha} + \frac{1}{2} \langle S^V(e_i) f_{\alpha}^{H,V}, f_{\beta}^{H,V} \rangle \frac{f^{\alpha} f^{\beta}}{u^2} \right)^2 \\ + \frac{u^2 K}{8} + \frac{u^2}{4} c(e_i) c(e_j) R'^{\xi}(e_i, e_j) + \frac{u c(e_i)}{\sqrt{2}} f^{\alpha} \\ R'^{\xi}(e_i, f_{\alpha}^{H,V}) + \frac{1}{2} f^{\alpha} f^{\beta} R'^{\xi}(f_{\alpha}^{H,V}, f_{\beta}^{H,V}) \\ + uT \frac{c(e_i)}{\sqrt{2}} \nabla_{e_i}^{\xi} V + T f^{\alpha} \nabla_{f_{\alpha}^{H,V}}^{\xi} V + T^2 V^2.$$

Proof. Formula (7.47) follows from [4, Theorem 3.6] and from the commutation relation

$$(7.48) \quad [c(U), V] = 0 \quad , \quad U \in T_{\mathbf{R}}X, \\ [f^{\alpha}, V] = 0.$$

□

Theorem 7.20 — For $u > 0$, $T > 0$, the following identity holds

$$(7.49) \quad \tilde{A}_{u,T}^2 = -\frac{u^2}{2} \left\{ e^{-f^\gamma \frac{c}{\sqrt{2u}} (f_\gamma^{H,N^{Y/X}})} \left(\nabla_{e_i}^{\Lambda(T^{*(0,1)}X)} \widehat{\otimes} \xi + \frac{1}{2} \langle S^V(e_i) e_j, f_\alpha^{H,V} \rangle \right. \right. \\ \left. \left. \sqrt{2} c(e_j) \frac{f^\alpha}{u} + \frac{1}{2} \langle S^V(e_i) f_\alpha^{H,V}, f_\beta^{H,V} \rangle \frac{f^\alpha f^\beta}{u^2} \right) e^{f^\gamma \frac{c}{\sqrt{2u}} (f_\gamma^{H,N^{Y/X}})} \right\}^2 \\ + \frac{u^2 K}{8} + \frac{u^2}{4} c(e_i) c(e_j) R'^\xi(e_i, e_j) + \frac{u}{\sqrt{2}} c(e_i) f^\alpha R'^\xi(e_i, f_\alpha^{H,W}) \\ + \frac{1}{2} f^\alpha f^\beta R'^\xi(f_\alpha^{H,W}, f_\beta^{H,W}) + uT \frac{c(e_i) \nabla_{e_i}^\xi V}{\sqrt{2}} + T f^\alpha \nabla_{f_\alpha^{H,W}}^\xi V + T^2 V^2.$$

Proof. Identity (7.49) follows from (7.40) and (7.47). □

Remark 7.21. With respect to (7.47), note that in (7.49), $T f^\alpha \nabla_{f_\alpha^{H,V}}^\xi V$ has been changed into $T f^\alpha \nabla_{f_\alpha^{H,W}}^\xi V$.

8. A Taylor expansion of the superconnection $\tilde{A}_{1,T}$ near W

The purpose of this Chapter is to give an asymptotic expansion as $T \rightarrow +\infty$ of the superconnection $\tilde{A}_{1,T}$ in a neighborhood of W in V , after a change of variable in $N_{Y/X, \mathbf{R}}$, $Z \rightarrow \frac{Z}{\sqrt{T}}$. This Chapter is the obvious extension of [19, Section 8]. In particular the remarkable identities of Theorems 1.10 and 1.11 play a key role in the description of the asymptotic expansion.

This Chapter is organized as follows. In Section 8.1, we give a trivialization of $\Lambda(T^{*(0,1)}X) \hat{\otimes} \xi$ near W along geodesics in the fibres X , which are normal to Y . In Section 8.2, we calculate the Taylor expansion of $\tilde{A}_{1,T}$. Finally in Section 8.3, we give a remarkable algebraic identity which relates the constant term in the asymptotic expansion of $\tilde{A}_{1,T}$ to the superconnection B_1^W .

In this Chapter, the assumptions and notation of Chapter 7 are in force.

8.1 A trivialization of $\Lambda(T^{*(0,1)}X) \hat{\otimes} \xi$ along geodesics normal to Y

In this Section, we use the coordinate system on V near W constructed in Section 7.3. Also recall that the connection $\tilde{\nabla}^\xi$ on $\xi|_{U_{y_0}}$ was defined in Definition 7.7.

Take $x = (y, Z) \in \mathcal{U}_{\varepsilon_0}$. We identify ξ_x to ξ_y by parallel transport with respect to the connection $\tilde{\nabla}^\xi$ along the geodesic $t \in [0, 1] \rightarrow (y, tZ)$. Under this identification, ξ_x^\pm is identified to ξ_y^\pm , and the identification preserves the metrics and the \mathbf{Z} -grading of ξ . Also if $x = (y, Z)$, $V(x)$, $V^+(x)$, $V^-(x)$ act as self-adjoint operators on ξ_y , ξ_y^+ , ξ_y^- .

If $x = (y, Z) \in \mathcal{U}_{\varepsilon_0}$, we identify TX_x , $\Lambda(T^{*(0,1)}X)_x$ to TX_y , $\Lambda(T^{*(0,1)}X)_y$ by parallel transport with respect to ∇^{TX} , $\nabla^{\Lambda(T^{*(0,1)}X)}$ along $t \in [0, 1] \rightarrow (y, tZ)$. This identification preserves the metrics and the \mathbf{Z} -grading.

If $x = (y, Z) \in \mathcal{U}_{\varepsilon_0}$, $(\Lambda(T^{*(0,1)}X) \hat{\otimes} \xi)_x$ is thus identified to $(\Lambda(T^{*(0,1)}X) \hat{\otimes} \xi)_y$, and this identification preserves the metrics and the \mathbf{Z} -gradings.

8.2 A Taylor expansion for $\tilde{A}_{1,T}$ near W

Recall that π is the canonical projection $N_{Y/X} \rightarrow W$. For $\alpha > 0, s \in S$, set

$$(8.1) \quad B_{\alpha,s} = \{Z \in N_{Y/X, \mathbf{R}|_{Y_s}}, |Z| < \alpha\}.$$

If $0 < \alpha < \varepsilon_0$, let $\mathcal{U}_{\alpha,s}$ be the corresponding tubular neighborhood of Y_s in X_s constructed in Section 7.3.

Definition 8.1. Take $\alpha > 0$. Given $s \in S$, let $\mathbf{E}_s(\alpha)$ (resp. \mathbf{E}_s) be the set of smooth sections of $\pi^*((\Lambda(T^{*(0,1)}X) \hat{\otimes} \xi)|_{Y_s})$ on $B_{\alpha,s}$ (resp. on the total space of $N_{Y/X|_{Y_s}}$).

The $\mathbf{E}_s(\alpha)$'s, \mathbf{E}_s 's are the fibres of vector bundles $\mathbf{E}(\alpha)$, \mathbf{E} on S . If $s \in S, f, g \in \mathbf{E}_s$ have compact support, put

$$(8.2) \quad \langle f, g \rangle = \left(\frac{1}{2\pi} \right)^{\dim X} \int_{Y_s} \left\{ \int_{N_{Y/X, \mathbf{R}, y}} \langle f, g \rangle(y, Z) dv_{N_{Y/X}}(Z) \right\} dv_{Y_s}(y).$$

By using the construction of Section 7.3, if $f \in \mathbf{E}_s$ has compact support in $B_{\varepsilon_0,s}$, we may and we will identify f to an element of E_s with compact support in $\mathcal{U}_{\varepsilon_0,s}$.

The holomorphic Hermitian connection $\nabla^{N_{Y/X}}$ induces a splitting $TN_{Y/X} = N_{Y/X} \oplus T^H N_{Y/X}$, where $T^H N_{Y/X}$ is the horizontal part of $TN_{Y/X}$ with respect to $\nabla^{N_{Y/X}}$. If $U \in T_{\mathbf{R}}W$, let $U^H \in T_{\mathbf{R}}^H N_{Y/X}$ be the corresponding lift of U , so that $\pi_* U^H = U$. If $U \in T_{\mathbf{R}}S$, then $(U^{H,W})^H \in T_{\mathbf{R}}^H N_{Y/X}$ is well-defined.

Recall that the connection ${}^0\nabla^{TX|_W}$ on $TX|_W$ was defined in (1.31). Let ${}^0\nabla^{\Lambda(T^{*(0,1)}X)|_W}$ be the corresponding connection on $\Lambda(T^{*(0,1)}X)|_W$. Let ${}^0\tilde{\nabla}^{(\Lambda(T^{*(0,1)}X) \hat{\otimes} \xi)|_W}$ be the connection on $(\Lambda(T^{*(0,1)}X) \hat{\otimes} \xi)|_W$ associated to ${}^0\nabla^{\Lambda(T^{*(0,1)}X)|_W}$ and to $\tilde{\nabla}^\xi$. This connection lifts to a connection on $\pi^*((\Lambda(T^{*(0,1)}X) \hat{\otimes} \xi)|_W)$, which we still note ${}^0\tilde{\nabla}^{(\Lambda(T^{*(0,1)}X) \hat{\otimes} \xi)|_W}$.

Let $e_1, \dots, e_{2\ell'}$ be an orthonormal basis of $T_{\mathbf{R}}Y$, let $e_{2\ell'+1}, \dots, e_{2\ell}$ be an orthonormal basis of $N_{Y/X, \mathbf{R}}$. Then $e_1, \dots, e_{2\ell}$ is an orthonormal basis of $(T_{\mathbf{R}}X)|_W$.

Now we follow [19, Definition 8.16].

Definition 8.2. Set

$$(8.3) \quad \begin{aligned} D^H &= \sum_{i=1}^{2\ell'} \frac{c(e_i)}{\sqrt{2}} {}^0\tilde{\nabla}_{e_i^H}^{(\Lambda(T^{*(0,1)}X) \hat{\otimes} \xi)|_W}, \\ D^{N_{Y/X}} &= \sum_{i=2\ell'+1}^{2\ell} \frac{c(e_i)}{\sqrt{2}} {}^0\tilde{\nabla}_{e_i}^{(\Lambda(T^{*(0,1)}X) \hat{\otimes} \xi)|_W}. \end{aligned}$$

Then the operators $D^H, D^{N_{Y/X}}$ act naturally on the fibres of \mathbf{E} .

To simplify the exposition, we will assume that $T_{\mathbf{R}}S$ is equipped with a Hermitian metric and that $\nabla^{T_{\mathbf{R}}S}$ is the corresponding Levi-Civita connection.

If $U \in T_{\mathbf{R}}N_{Y/X}$, $(\pi_W \pi)_* U = 0$, then ${}^0\tilde{\nabla}_U^{\Lambda(T^{*(0,1)}X) \widehat{\otimes} \xi}|_W$ acts naturally on smooth sections of $\pi^*(\pi_W^* \Lambda(T_{\mathbf{R}}^* S) \widehat{\otimes} (\Lambda(T^{*(0,1)}X) \widehat{\otimes} \xi)|_W)$. Our choice of $\nabla^{T_{\mathbf{R}}S}$ makes that this action extends to the general case, where $U \in T_{\mathbf{R}}N_{Y/X}$.

For $T \geq 1$, let Q_T be a first order differential operator acting on smooth sections of $\pi^*(\pi_W^* \Lambda(T_{\mathbf{R}}^* S) \widehat{\otimes} (\Lambda(T^{*(0,1)}X) \widehat{\otimes} \xi)|_W)$ over $N_{Y/X, \mathbf{R}}$. Then Q_T can be written in the form

$$(8.4) \quad Q_T = \sum_1^{2\ell'} a_i(T, y, Z) {}^0\nabla_{e_i^H}^{\Lambda(T^{*(0,1)}X) \widehat{\otimes} \xi}|_W + \sum_{2\ell'+1}^{2\ell} b_i(T, y, Z) {}^0\tilde{\nabla}_{e_i}^{\Lambda(T^{*(0,1)}X) \widehat{\otimes} \xi}|_W + \sum_1^{2m} c_\alpha(T, y, Z) {}^0\tilde{\nabla}_{(f_\alpha^{H,W})^H}^{\Lambda(T^{*(0,1)}X) \widehat{\otimes} \xi}|_W + d(T, y, Z),$$

where $a_i(T, y, Z)$, $b_i(T, Y, Z)$, $c_\alpha(T, y, Z)$, $d(T, y, Z)$ are endomorphisms depending smoothly of (y, Z) .

Assume there is $C > 0$, $p \in \mathbf{N}$ such that if $(y, Z) \in B_{\varepsilon_0 \sqrt{T}}$, then

$$(8.5) \quad \begin{aligned} |a_i(T, y, Z)| &\leq C |Z|, \quad 1 \leq i \leq 2\ell', \\ |b_i(T, y, Z)| &\leq C |Z|^2, \quad 2\ell' + 1 \leq i \leq 2\ell, \\ |c_\alpha(T, y, Z)| &\leq C |Z|, \quad 1 \leq \alpha \leq 2m, \\ |d(T, Y, Z)| &\leq C(|Z| + |Z|^p). \end{aligned}$$

We will then use the notation

$$(8.6) \quad Q_T = \mathcal{O}(|Z|^2 \partial^{N_{Y/X}} + |Z| \partial^Y + |Z| \partial^S + |Z| + |Z|^p).$$

Let $A^{\Lambda(T^{*(0,1)}X)}$ be the obvious action of A on $\Lambda(T^{*(0,1)}X)$. This action extends to $\Lambda(T^{*(0,1)}X) \widehat{\otimes} \xi$.

Take $y \in W$, $Z \in N_{Y/X, \mathbf{R}, y}$. Let $\frac{\tilde{D}}{Dt}$ be the covariant differentiation operator with respect to $\tilde{\nabla}^\xi$ along $t \rightarrow (y, tZ)$. In the sequel, we use the notation

$$(8.7) \quad \tilde{\nabla}_Z^\xi \tilde{\nabla}_Z^\xi V(y) = \frac{\tilde{D}^2}{Dt^2} V(y, tZ)|_{t=0}.$$

Then $\tilde{\nabla}_Z^\xi \tilde{\nabla}_Z^\xi V(y)$ depends quadratically on Z .

Definition 8.3. For $T > 0$, if $f \in \mathbf{E}(\varepsilon_0)$, let $F_T f \in \mathbf{E}(\varepsilon_0 \sqrt{T})$ be given by

$$(8.8) \quad F_T f(y, Z) = f\left(y, \frac{Z}{\sqrt{T}}\right).$$

Using the trivialization of $(\Lambda(T^{*(0,1)}X)\widehat{\otimes}\xi)|_{\mathcal{U}_{\varepsilon_0}}$ along geodesics normal to Y , we find that the restriction of $\tilde{A}_{u,T}$ to $\mathcal{U}_{\varepsilon_0}$ acts naturally on smooth sections of $\Lambda(T_{\mathbf{R}}^*S)\widehat{\otimes}\mathbf{E}(\varepsilon_0)$, and so it defines a superconnection on $\mathbf{E}(\varepsilon_0)$. Then for $T \geq 1$, $F_T k^{1/2}\tilde{A}_{u,T}k^{-1/2}F_T^{-1}$ is a superconnection on $\mathbf{E}(\varepsilon_0\sqrt{T})$.

Definition 8.4. Let \mathfrak{B} be the superconnection on \mathbf{E} ,

$$(8.9) \quad \mathfrak{B} = D^H + \sum_1^{2\ell} \frac{c(e_i)}{\sqrt{2}} B_y(e_i) + \frac{1}{2} \tilde{\nabla}_Z^\xi \tilde{\nabla}_Z^\xi V(y) \\ + f^\alpha \wedge \left({}^0\tilde{\nabla}_{(f_\alpha^{H,W})_H} (\Lambda(T^{*(0,1)}X)\widehat{\otimes}\xi)|_W + B_y(f_\alpha^{H,W}) \right) \\ + \frac{1}{2} f^\alpha \wedge f^\beta \frac{c}{2\sqrt{2}} \left(P^{N_{Y/X}} T^V (f_\alpha^{H,W}, f_\beta^{H,W}) - T^W (f_\alpha^{H,W}, f_\beta^{H,W}) \right).$$

Now we prove the relevant extension of [19, Theorem 8.18].

Theorem 8.5 — As $T \rightarrow +\infty$,

$$(8.10) \quad F_T k^{1/2} \tilde{A}_{1,T} k^{-1/2} F_T^{-1} = TV^+(y) + \sqrt{T} (D^{N_{Y/X}} + \tilde{\nabla}_Z^\xi V(y)) \\ + \mathfrak{B} + \frac{1}{\sqrt{T}} \mathcal{O} \left(|Z|^2 \partial^{N_{Y/X}} + |Z| \partial^Y + |Z| \partial^S + |Z| + |Z|^3 \right).$$

Proof. Let f_1, \dots, f_m be a locally defined smooth basis of $T_{\mathbf{R}}S$, such that

$$(8.11) \quad [f_\alpha, f_\beta] = 0.$$

We use Theorem 7.17, which gives a formula for $\tilde{A}_{u,T}$. We will establish (8.10) by considering the various term of degree 0, 1, 2, 3 in the Grassmann variables of $\Lambda(T_{\mathbf{R}}^*S)$. By [19, Theorem 8.18], (8.10) holds in degree 0.

Recall that A was defined in (1.32). Then for $U \in T_{\mathbf{R}}W$, $A(U) \in \text{End}(TX)$. Let $A^{\Lambda(T^{*(0,1)}X)}$ be the obvious action of A on $\Lambda(T^{*(0,1)}X)|_W$. Recall that $\nabla^{\Lambda(T^{*(0,1)}X)\widehat{\otimes}\xi}$ and ${}^0\nabla^{\Lambda(T^{*(0,1)}X)\widehat{\otimes}\xi}|_W$ can be considered as connections on $\pi^*((\Lambda(T^{*(0,1)}X)\widehat{\otimes}\xi)|_W)$. Set

$$(8.12) \quad \Gamma_y = \left(\nabla^{\Lambda(T^{*(0,1)}X)\widehat{\otimes}\xi} - {}^0\tilde{\nabla}^{\Lambda(T^{*(0,1)}X)\widehat{\otimes}\xi}|_W \right)_y.$$

Clearly on W ,

$$(8.13) \quad \Gamma_y = A_y^{\Lambda(T^{*(0,1)}X)} + B_y.$$

Then on W ,

$$(8.14) \quad f^\alpha \wedge \left(\nabla_{f_\alpha^{H,W}}^{\Lambda(T^{*(0,1)}X)\widehat{\otimes}\xi} - \frac{1}{2} c(e_i) c(\nabla_{e_i}^{TX} f_\alpha^{H,N_{Y/X}}) \right) \\ = f^\alpha \wedge \left({}^0\tilde{\nabla}_{f_\alpha^{H,W}}^{\Lambda(T^{*(0,1)}X)\widehat{\otimes}\xi}|_W + \Gamma(f_\alpha^{H,W}) - \frac{1}{2} c(e_i) c(\nabla_{e_i}^{TX} f_\alpha^{H,N_{Y/X}}) \right).$$

Take $y_0 \in W$. Let $(y^1, \dots, y^{\ell'})$ be a holomorphic system of coordinates on a neighborhood \mathcal{W} of $y_0 \in W$ in W . We assume that $N_{Y/X, \mathbf{R}} \simeq N_{W/V, \mathbf{R}}$ is trivialized over \mathcal{W} , so that $\pi^{-1}(\mathcal{W}) = \mathcal{W} \times \mathbf{R}^{2(\ell-\ell')}$. Set $\mathcal{V} = B_{\varepsilon_0} \cap \pi^{-1}(\mathcal{W})$. The map $(y, Z) \in \mathcal{V} \rightarrow \exp_y^X(Z) \in V$ identifies \mathcal{V} with an open neighborhood of y_0 in V , on which $T_{\mathbf{R}}V$ splits into

$$(8.15) \quad T_{\mathbf{R}}V = \mathbf{R}^{2(\ell'+m)} \oplus \mathbf{R}^{2(\ell-\ell')}.$$

Of course $\mathbf{R}^{2(\ell'+m)}, \mathbf{R}^{2(\ell-\ell')}$ are integrable subbundles of $T_{\mathbf{R}}V|_{\mathcal{V}}$. Moreover on W , the splitting (8.15) coincides with the splitting

$$(8.16) \quad T_{\mathbf{R}}V = T_{\mathbf{R}}W \oplus N_{Y/X, \mathbf{R}}.$$

Let p_1, p_2 be the projection operators from $T_{\mathbf{R}}V$ on $\mathbf{R}^{2(\ell'+m)}, \mathbf{R}^{2(\ell-\ell')}$ respectively. Clearly,

$$(8.17) \quad F_T k^{1/2} f^\alpha \wedge {}^0 \tilde{\nabla}_{f_\alpha^{H,W}} (\Lambda(T^{*(0,1)} X \otimes \xi)|_W) k^{-1/2} F_T^{-1} = \\ f^\alpha \wedge \left({}^0 \tilde{\nabla}_{p_1 f_\alpha^{H,W}(y, \frac{Z}{\sqrt{T}})} (\Lambda(T^{*(0,1)} X \otimes \xi)|_W) + {}^0 \tilde{\nabla}_{\sqrt{T} p_2 f_\alpha^{H,W}(y, \frac{Z}{\sqrt{T}})} (\Lambda(T^{*(0,1)} X \otimes \xi)|_W) - \frac{\nabla_{f_\alpha^{H,W}} k}{2k} (y, Z/\sqrt{T}) \right).$$

Since on W , $f_\alpha^{H,W} \in T_{\mathbf{R}}W$, we find that as $T \rightarrow +\infty$,

$$(8.18) \quad p_2 \sqrt{T} f_\alpha^{H,W} \left(y, \frac{Z}{\sqrt{T}} \right) = \frac{\partial}{\partial t} p_2 f_\alpha^{H,W} (y, tZ)|_{t=0} + \frac{1}{\sqrt{T}} \mathcal{O}(|Z|^2).$$

Let $\nabla^{T_{\mathbf{R}}V}$ be the connection on $T_{\mathbf{R}}V = T_{\mathbf{R}}^H V \oplus T_{\mathbf{R}}X$,

$$(8.19) \quad \nabla^{T_{\mathbf{R}}V} = \pi_V^* \nabla^{T_{\mathbf{R}}S} \oplus \nabla^{T_{\mathbf{R}}X}.$$

Recall that by Section 1.1, T^V is exactly the torsion of $\nabla^{T_{\mathbf{R}}V}$.

Let C be the Christoffel symbol of $\nabla^{T_{\mathbf{R}}V}$ in the trivialization of $T_{\mathbf{R}}V$ considered above. Then

$$(8.20) \quad \frac{\partial}{\partial t} f_\alpha^{H,W} (y, tZ)|_{t=0} = -C_y(Z) f_\alpha^{H,W} + \nabla_Z^{T_{\mathbf{R}}V} f_{\alpha,y}^{H,W}.$$

Now by definition

$$(8.21) \quad -C_y(Z) f_\alpha^{H,W} = -C_y(f_\alpha^{H,W})Z + T_y^V(f_\alpha^{H,W}, Z).$$

Also by (7.25),

$$(8.22) \quad \nabla_Z^{T_{\mathbf{R}}V} f_{\alpha,y}^{H,W} + T_y^V(f_\alpha^{H,W}, Z) = 0.$$

Using (8.20)-(8.22), we obtain

$$(8.23) \quad \frac{\partial}{\partial t} f_\alpha^{H,W} (y, tZ) = -C_y(f_\alpha^{H,W})Z.$$

Also by Proposition 7.2, $\nabla^{N_{Y/X}} = P^{N_{Y/X}} \nabla^{TX}|_W$, and so with respect so the local trivialization of $N_{Y/X}$,

$$(8.24) \quad (f_\alpha^{H,W})^H = f_\alpha^{H,W} - p_2 C_y(f_\alpha^{H,W}) Z.$$

Finally, since $k|_W = 1$ on W ,

$$(8.25) \quad \nabla_{f_\alpha^{H,W}} k|_W = 0.$$

By (8.13)-(8.25), we obtain

$$(8.26) \quad \begin{aligned} F_T k^{1/2} f_\alpha \wedge \left(\nabla_{f_\alpha^{H,W}}^{\Lambda(T^{*(0,1)} X \otimes \xi)} - \frac{1}{2} c(e_i) c(\nabla_{e_i}^{TX} f_\alpha^{H,N_{Y/X}}) \right) k^{-1/2} F_T^{-1} \\ = f_\alpha \wedge \left({}_0 \tilde{\nabla}_{(f_\alpha^{H,W})^H}^{\Lambda(T^{*(0,1)} X \otimes \xi)}|_W + A_y^{\Lambda(T^{*(0,1)} X)}(f_\alpha^{H,W}) + B_y(f_\alpha^{H,W}) \right. \\ \left. - \frac{1}{2} c(e_i) c(\nabla_{e_i}^{TX} f_{\alpha,y}^{H,N_{Y/X}}) \right) + \frac{1}{\sqrt{T}} \mathcal{O}(|Z|^2 \partial^{N_{Y/X}} + |Z| \partial^Y + |Z| \partial^S + |Z|). \end{aligned}$$

By (1.35), on W

$$(8.27) \quad \begin{aligned} \sum_1^{2\ell'} c(e_i) c(\nabla_{e_i}^{TX} f_\alpha^{H,N_{Y/X}}) &= \sum_1^{2\ell'} c(e_i) c\left(A(e_i) f_\alpha^{H,N_{Y/X}} \right. \\ &\quad \left. + P^{N_{Y/X}} T^V(e_i, f_\alpha^{H,V}) + A(f_\alpha^{H,W}) e_i\right) \\ &= \sum_1^{2\ell'} c(e_i) c\left(T^V(e_i, f_\alpha^{H,V}) - T^W(e_i, f_\alpha^{H,W}) + A(f_\alpha^{H,W}) e_i\right) \\ &= \sum_1^{2\ell'} c(e_i) c\left(T^V(e_i, f_\alpha^{H,V})\right) - \sum_1^{2\ell'} c(e_i) c\left(T^W(e_i, f_\alpha^{H,W})\right) \\ &\quad + \sum_{\substack{1 \leq i \leq 2\ell' \\ 2\ell'+1 \leq j \leq 2\ell}} \langle A(f_\alpha^{H,W}) e_i, e_j \rangle c(e_i) c(e_j). \end{aligned}$$

By (7.26), on W

$$(8.28) \quad \sum_{2\ell'+1}^{2\ell} c(e_i) c(\nabla_{e_i}^{TX} f_\alpha^{H,N_{Y/X}}) = \sum_{2\ell'+1}^{2\ell} c(e_i) c\left(T^V(e_i, f_\alpha^{H,V})\right).$$

Also since $A(f_\alpha^{H,W})|_W$ interchanges TY and $N_{Y/X}$, on W

$$(8.29) \quad A^{\Lambda(T^{*(0,1)} X)}(f_\alpha^{H,W}) = \frac{1}{2} \sum_{\substack{1 \leq i \leq 2\ell' \\ 2\ell'+1 \leq j \leq 2\ell}} \langle A(f_\alpha^{H,W}) e_i, e_j \rangle c(e_i) c(e_j).$$

By (8.27)-(8.29), we find that on W ,

$$(8.30) \quad A^{\Lambda(T^{*(0,1)X})}(f_{\alpha}^{H,W}) - \frac{1}{2}c(e_i)c(\nabla_{e_i}^{TX} f_{\alpha}^{H,N_{Y/X}}) = \\ - \frac{1}{2} \sum_1^{2\ell} c(e_i)c(T^V(e_i, f_{\alpha}^{H,V})) + \frac{1}{2} \sum_1^{2\ell'} c(e_i)c(T^W(e_i, f_{\alpha}^{H,W})).$$

Now using (1.6) and (2.11), we get

$$(8.31) \quad \sum_1^{2\ell} c(e_i)c(T^V(e_i, f_{\alpha}^{H,V})) = \sum_{1 \leq i, j \leq 2\ell} \langle T^V(e_i, f_{\alpha}^{H,V}), e_j \rangle c(e_i)c(e_j) \\ = - \sum_1^{2\ell} \langle T^V(e_i, f_{\alpha}^{H,V}), e_i \rangle \\ = \sum_1^{2\ell} \langle S^V(e_i) f_{\alpha}^{H,V}, e_i \rangle \\ = - \left\langle f_{\alpha}^{H,V}, \sum_1^{2\ell} S^V(e_i) e_i \right\rangle = 0.$$

By the same argument,

$$(8.32) \quad \sum_1^{2\ell'} c(e_i)c(T^W(e_i, f_{\alpha}^{H,W})) = 0.$$

So from (8.30)-(8.32), we obtain

$$(8.33) \quad A_y^{\Lambda(T^{*(0,1)X})}(f_{\alpha}^{H,W}) - \frac{1}{2}c(e_i)c(\nabla_{e_i}^{TX} f_{\alpha}^{H,N_{Y/X}}) = 0.$$

By Theorem 7.17, (8.26) and (8.33), we see that (8.10) holds in degree 1.

Now we consider the term of degree 2 in (7.37). By Theorem 1.11, on W , we get

$$(8.34) \quad \sum_{i=1}^{2\ell'} \frac{1}{2} f^{\alpha} f^{\beta} \left(- \frac{1}{2} \langle T^V(f_{\alpha}^{H,V}, f_{\beta}^{H,V}), e_i \rangle - \langle f_{\alpha}^{H,N_{Y/X}}, \nabla_{e_i}^{TX} f_{\beta}^{H,N_{Y/X}} \rangle \right. \\ \left. + 2 \langle \nabla_{f_{\alpha}^{H,W}}^{TX} f_{\beta}^{H,N_{Y/X}}, e_i \rangle \right) \frac{c(e_i)}{\sqrt{2}} = - \frac{1}{2} f^{\alpha} f^{\beta} \frac{c}{2\sqrt{2}} (T^W(f_{\alpha}^{H,W}, f_{\beta}^{H,W})).$$

Moreover using (1.6), (7.27), and the fact that $[f_\alpha, f_\beta] = 0$, $[f_\alpha^{H,W}, f_\beta^{H,W}] \in T_{\mathbf{R}}W$,

$$\begin{aligned}
(8.35) \quad & \sum_{i=2\ell'+1}^{2\ell} \frac{1}{2} f^\alpha f^\beta \left(-\frac{1}{2} \langle T^V(f_\alpha^{H,V}, f_\beta^{H,V}), e_i \rangle - \right. \\
& \left. - \langle f_\alpha^{H, N_{Y/X}}, \nabla_{e_i}^{TX} f_\beta^{H, N_{Y/X}} \rangle + 2 \langle \nabla_{f_\alpha^{H,W}}^{TX} f_\beta^{H, N_{Y/X}}, e_i \rangle \right) \frac{c(e_i)}{\sqrt{2}} = \\
& \sum_{i=2\ell'+1}^{2\ell} \frac{1}{2} f^\alpha f^\beta \left(-\frac{1}{2} \langle T^V(f_\alpha^{H,V}, f_\beta^{H,V}), e_i \rangle + \right. \\
& \left. \langle f_\alpha^{H, N_{Y/X}}, T^V(f_\beta^{H,V}, e_i) \rangle + 2 \langle \nabla_{f_\alpha^{H,W}}^{TX} (f_\beta^{H,W} - f_\beta^{H,V}), e_i \rangle \right) \frac{c(e_i)}{\sqrt{2}} \\
& = \sum_{i=2\ell'+1}^{2\ell} \frac{1}{2} f^\alpha f^\beta \left(\left\langle -\frac{1}{2} T^V(f_\alpha^{H,V}, f_\beta^{H,V}) + T^V(f_\beta^{H,V}, f_\alpha^{H, N_{Y/X}}) \right. \right. \\
& \quad \left. \left. + T^V(f_\alpha^{H,W}, f_\beta^{H,W}), e_i \right\rangle \right) \frac{c(e_i)}{\sqrt{2}} \\
& = \frac{1}{2} f^\alpha f^\beta \frac{c}{2\sqrt{2}} (P^{N_{Y/X}} T^V(f_\alpha^{H,W}, f_\beta^{H,W})).
\end{aligned}$$

Using Theorem 7.17 and (8.34), (8.35), we find that (8.10) also holds in degree 2.

Finally by Theorems 1.11 and 7.17, (8.10) holds in degree 3. The proof of our Theorem is completed. \square

8.3 The projection of the superconnection \mathfrak{B}

Definition 8.6. If $s \in S$, let \mathbf{E}_s^\pm be the set of smooth sections of $\pi^*((\Lambda(T^{*(0,1)}X) \hat{\otimes} \xi^\pm)|_{Y_s})$ on $N_{Y/X, \mathbf{R}}|_{Y_s}$.

Then \mathbf{E}_s splits into

$$(8.36) \quad \mathbf{E}_s = \mathbf{E}_s^+ \oplus \mathbf{E}_s^-.$$

The operators D^H and $D^{N_{Y/X}}$ preserve \mathbf{E}^\pm . Let $D^{H, \pm}$, $D^{N_{Y/X}, \pm}$ be the restriction of D^H , $D^{N_{Y/X}}$ to \mathbf{E}^\pm . Let \mathbf{E}_s^0 , $\mathbf{E}_s^{\pm, 0}$ be the Hilbert spaces of square integrable sections of $\pi^*((\Lambda(T^{*(0,1)}X) \hat{\otimes} \xi)|_{Y_s})$, $\pi^*((\Lambda(T^{*(0,1)}X) \hat{\otimes} \xi^\pm)|_{Y_s})$ on $N_{Y/X, \mathbf{R}, Y_s}$. We equip \mathbf{E}_s^0 , $\mathbf{E}_s^{\pm, 0}$ with the Hermitian product (8.2). Then \mathbf{E}_s^0 splits orthogonally as

$$(8.37) \quad \mathbf{E}_s^0 = \mathbf{E}_s^{+, 0} \oplus \mathbf{E}_s^{-, 0}.$$

Let F_s^0 be the Hilbert space of square integrable sections of $(\Lambda(T^{*(0,1)}Y) \otimes \eta)|_{Y_s}$ over Y_s . We equip F_s^0 with the Hermitian product constructed in (2.22).

Of course the $\mathbf{E}_s^0, \mathbf{E}_s^{\pm, 0}, \dots$ are the fibres of corresponding vector bundles $\mathbf{E}^0, \mathbf{E}^{\pm, 0}, \dots$ over S .

Using (3.28), (3.29), (7.17), we have the identity of smooth Hermitian vector bundles on W

$$(8.38) \quad (\Lambda(T^{*(0,1)}X) \widehat{\otimes} \xi^-)|_W = \Lambda(T^{*(0,1)}Y) \widehat{\otimes} \Lambda(\overline{N}_{Y/X}^*) \widehat{\otimes} (\Lambda(N_{Y/X}^*) \otimes \eta).$$

If $y \in Y$, let θ_y be the Kähler form of the fibre $N_{Y/X, \mathbf{R}, y}$. More precisely, if $J^{N_{Y/X, \mathbf{R}, y}}$ is the complex structure of $N_{Y/X, \mathbf{R}, y}$, if $f, f' \in N_{Y/X, \mathbf{R}, y}$, then

$$(8.39) \quad \theta_y(f, f') = \langle f, J^{N_{Y/X, \mathbf{R}, y}} f' \rangle.$$

Then θ_y is a $(1, 1)$ form on the fibres of $N_{Y/X, \mathbf{R}}$.

If $y \in W$, $Z \in N_{Y/X, \mathbf{R}, y}$, set

$$(8.40) \quad \beta_y = \exp\left(-\frac{|Z|^2}{2} + \theta_y\right).$$

Then $\beta_y \in \left(\Lambda(\overline{N}_{Y/X, \mathbf{R}}^*) \otimes \Lambda(N_{Y/X, \mathbf{R}}^*)\right)_y$.

By [6, Theorem 1.6] or [19, Theorem 7.4], for any $y \in W$, β_y spans the 1-dimensional L_2 kernel of the elliptic operator $D^{N_{Y/X}} + \sqrt{-1} \frac{\widehat{c}(Z)}{\sqrt{2}}$ acting on the vector space of L_2 smooth sections of $\pi^* \left(\Lambda(\overline{N}_{Y/X}^*) \otimes \Lambda(N_{Y/X}^*)\right)_y$ on $N_{Y/X, \mathbf{R}, y}$, and moreover

$$(8.41) \quad \int_{N_{Y/X, \mathbf{R}}} \|\beta\|^2 \frac{dv_{N_{Y/X}}}{(2\pi)^{\dim N_{Y/X}}} = 1.$$

Definition 8.7. Let ψ be the linear map

$$(8.42) \quad \psi: \sigma \in F^0 \rightarrow \pi^* \sigma \beta \in \mathbf{E}^0.$$

Let \mathbf{E}'^0 be the image of F^0 by ψ . Then $\mathbf{E}'^0 \subset \mathbf{E}^{-,0}$.

By [19, Theorem 7.4] or by (8.41), ψ is an isometry, and so it identifies isometrically the vector bundles F^0 and \mathbf{E}'^0 on S .

Let p be the orthogonal projection operator from \mathbf{E}^0 on \mathbf{E}'^0 . Let q be the orthogonal projection operator from $(\Lambda(T^{*(0,1)}X) \widehat{\otimes} \xi^-)|_W$ on $\Lambda(T^{*(0,1)}Y) \widehat{\otimes} \{\exp(\theta)\} \otimes \eta$. By [19, eq. (8.91)], if $s \in \mathbf{E}^0$,

$$(8.43) \quad ps(y, Z) = \frac{1}{\pi^{\dim N_{Y/X}}} \exp\left(-\frac{|Z|^2}{2}\right) q \int_{N_{Y/X, \mathbf{R}, y}} \exp\left(-\frac{|Z'|^2}{2}\right) s(y, Z') dv_{N_{Y/X}}(Z').$$

Now we prove the obvious extension of [19, Theorem 8.21].

Theorem 8.8 — *The following identities hold,*

$$(8.44) \quad \begin{aligned} \psi^{-1} p \mathfrak{B} p \psi &= B_1^W, \\ \psi^{-1} p (\tilde{N}_1^V - N_{\mathbf{H}}) p \psi &= N_1^W, \\ \psi^{-1} p N_{\mathbf{H}} p \psi &= \frac{1}{2} \dim N_{Y/X}. \end{aligned}$$

Proof. We will establish the first identity in (8.44), by comparing the terms of various degrees in $\Lambda(T_{\mathbf{R}}^* S)$. In degree 0, this was already established in [19, Theorem 8.21].

Clearly, if $U \in T_{\mathbf{R}} W$, since the identification (8.38) identifies the metrics,

$$(8.45) \quad \psi^{-1} p f^\alpha \wedge \overset{0}{\nabla}_{(f_\alpha^{H,W})^H} \tilde{\nabla}^{\Lambda(T^{*(0,1)} X) \otimes \xi} |_{\mathbf{W}} p \psi = f^\alpha \wedge \nabla_{f_\alpha^{H,W}}^{\Lambda(T^{*(0,1)} Y) \otimes \eta}.$$

Also because $B(f_\alpha^{H,W})$ exchanges ξ^- and ξ^+ ,

$$(8.46) \quad \psi^{-1} p B_y(f_\alpha^{H,W}) p \psi = 0.$$

If $U \in N_{Y/X, \mathbf{R}, y}$, $c(U)$ is the sum of two operators, one which increases the degree in $\Lambda(\tilde{N}_{Y/X}^*)$ by 1, and the other which decreases the degree by 1. Since β is of total degree 0,

$$(8.47) \quad p c(U) p = 0.$$

By (8.47), we get

$$(8.48) \quad p \frac{1}{2} f^\alpha f^\beta \frac{c}{2\sqrt{2}} (P^{N_{Y/X}} T^V (f_\alpha^{H,W}, f_\beta^{H,W})) p = 0.$$

From (8.10), (8.45)-(8.48), we get the first identity in (8.44).

By [19, Proposition 8.4], the second identity in (8.44) holds in degree 0. Since $T_{\mathbf{R}} Y$ and $T_{\mathbf{R}}^H W$ are orthogonal with respect to ω^V , using (7.37), (8.47), the second identity (8.44) also holds in degree 1, i.e. both sides vanish in degree 1. In degree 2, the second identity (8.44) follows from (7.37).

The third identity in (8.44) was already established in [19, Proposition 8.4]. The proof of our Theorem is completed. \square

Remark 8.9. Related forms of Theorems 8.5 and 8.8 are also established in Theorems 13.16, 13.17 and 13.32, 13.34. In particular, in Theorem 13.16, a more complicated trivialization produces a simpler expansion than the one in Theorem 8.5.

9. The asymptotics of supertraces involving the operator $\exp(-B_{u,T}^2)$ for large values of u, T

The purpose of this Chapter is to establish Theorems 6.5, 6.6 and 6.15, 6.16. It is the obvious extension of [19, Section 9], where the case where S is a point was considered.

In Theorems 6.5, 6.6 and 6.15, 6.16, we calculate the asymptotics of supertraces involving the operator $\exp(-B_{u,T}^2)$ when u or T tend to $+\infty$. The corresponding problem studied in [19, Section 9] involved the operator $\exp(-(u(D^X + TV))^2)$. The basic difficulty with respect to [19] is that while $D^X + TV$ is a standard elliptic differential operator, $B_{u,T}$ is a superconnection, and it is only when taking its square $B_{u,T}^2$ that we get a standard elliptic operator acting fibrewise. We are thus forced to deal directly with the operator $B_{u,T}^2$, while in [19, Section 9], the analysis was done directly on the simpler operator $D^X + TV$.

Still in [19, Section 13], when establishing Theorem 6.9 in the case where S is a point, i.e. when proving the uniform convergence as $T \rightarrow +\infty$ of supertraces involving $\exp(-(u(D^X + TV))^2)$ for $u \in [0, 1]$, because the analysis involved local index cancellation techniques which could not be applied to the operator $D^X + TV$, the analysis was also done on the square $(D^X + TV)^2$.

This is why, to prove Theorems 6.5, 6.6 and 6.15, 6.16, we essentially use the techniques of [19, Section 13], i.e. we prove the required convergence by establishing suitable estimates on the corresponding smooth kernels, these estimates being derived by a Lax-Milgram technique to control the resolvent in a functional analytic sense, together with commutator estimates to prove uniform regularity for the corresponding kernels. Needless to say, the results of Chapter 8 on the asymptotics of $\tilde{A}_{1,T}$ as $T \rightarrow +\infty$ play a key role in the identification of the limit of the supertraces as $T \rightarrow +\infty$.

Another basic difference with respect to [19, Section 9] is that for a given $T > 0$, in [19], the rate of convergence as $u \rightarrow +\infty$ of the considered supertraces was $\mathcal{O}(e^{-cu^2})$ (this result being obtained by a trivial argument of spectral theory), while here, the convergence is only $\mathcal{O}(\frac{1}{u})$, and is less easy to obtain (it follows from the result of [3, Theorem 9.19] explained in Theorem 2.20). While in [19, Section 9], the

corresponding uniformity argument was obtained by showing that as $T \rightarrow +\infty$, the module of the nonzero eigenvalues of $D^X + TV$ has a positive lower bound, here this argument breaks down.

To solve this difficulty, we observe that the spectrum of $B_{u,T}^2$ and $(u(D^X + TV))^2$ are identical. We then express $\exp(-B_{u,T}^2)$ as the sum of two contour integrals, one along a contour in $\{\lambda \in \mathbf{C}, \operatorname{Re}(\lambda) > 0\}$, and the other on a small circle centered at 0. To the first contour, we are able to apply arguments inspired from [19, Section 9]. As to the second contour, we prove that the corresponding supertrace is analytic in u near $u = +\infty$. The proof of uniformity of the convergence in $T \rightarrow +\infty$ as $u \rightarrow +\infty$ then follows from Cauchy's residue formula.

This Chapter is organized as follows. In Section 9.1, we describe the spectrum of $B_{u,T}^2$, and we express $\exp(-B_{u,T}^2)$ as a sum of two contour integrals. In Section 9.2, we give a simple scaling formula for the first contour integral. In Section 9.3, we state two intermediate results, from which Theorems 6.5 and 6.6 follow easily. Part of the remainder of the Chapter is devoted to the proofs of these intermediate results.

In Section 9.4, we show that $P^{\xi^-} f^\alpha \nabla_{f_\alpha^{H,W}}^\xi V P^{\xi^-}$ is $\mathcal{O}(|Z|^2)$ near W . In Section 9.5, by following [19, Section 9], we construct an embedding J_T of F into E . In Section 9.6, we construct a family of Sobolev norms $|\cdot|_{T,1}$ on the Sobolev bundle E^1 , and we show that $\tilde{A}_{1,T}^2$ verifies elliptic estimates with respect to these norms, which follow essentially from [19, Section 9]. It is at this stage that we find most useful to have replaced $A_{1,T}$ by $\tilde{A}_{1,T}$. In Section 9.7, we give functional analytic estimates for the resolvent of $\tilde{A}_{1,T}^2$. In Section 9.8, we establish regularizing properties of the resolvent of $\tilde{A}_{1,T}^2$ with respect to higher Sobolev spaces. In Section 9.9, we prove uniform estimates for the kernel of $F_u(\tilde{A}_{1,T}^2)$ (which is the first contour integral described before). In Section 9.10, by using Theorem 8.5, we obtain the matrix structure of $\tilde{A}_{1,T}^2$ with respect to a natural splitting of E , as $T \rightarrow +\infty$. In Section 9.11, we calculate the asymptotics of the operator $F_u(\tilde{A}_{1,T}^2)$ as $T \rightarrow +\infty$. In Section 9.12, we prove our first intermediate result of Section 9.3. Note that the argument of Sections 9.7-9.12 are already related to [19, Section 13].

In Section 9.13, we introduce a suitably rescaled version of $\tilde{A}_{u,T}^2$, which depends on three complex parameters, and we show that a corresponding operator obtained by a contour integral on a small circle is a polynomial function of these parameters. In Section 9.14, we prove the second intermediate result of Section 9.3. Finally in Sections 9.15 and 9.16, we show how to use the above techniques to prove Theorems 6.15 and 6.16.

In the whole Chapter, we use the assumptions and notation of Chapters 3-8.

9.1 The spectrum of $B_{u,T}^2$

For $T \geq 1$, set

$$(9.1) \quad A_T = A_{1,T}.$$

Let $A_T^{(0)}$ be the piece of A_T of partial degree 0 in $\Lambda(T_{\mathbf{R}}^*S)$. Then

$$(9.2) \quad A_T^{(0)} = D^X + TV.$$

Recall that $K' = \ker D^Y$ is a smooth vector bundle on S .

If $s \in S$, let $\nu(s)$ be the smallest nonzero eigenvalue of $D^{Y_s,2}$. Then $s \in S \rightarrow \nu(s) \in \mathbf{R}_+^*$ is a continuous function. Since S is compact, ν has a positive lower bound $2c_2 > 0$.

If C is an operator, let $\text{Sp}(C)$ be the spectrum of C .

Theorem 9.1 — *There exists $T_0 \geq 1$ such that for $s \in S, T \geq T_0$,*

$$(9.3) \quad \text{Sp}(A_T^{(0),2}) \cap \{\lambda \in \mathbf{R}_+^*, \lambda \leq c_2\} \subset \{0\}.$$

Proof. For a given $s \in S$, (9.3) is exactly [19, Theorem 9.25]. Since S is compact, a trivial uniformity argument shows that (9.3) holds. \square

Set

$$(9.4) \quad R_{u,T} = \left(\nabla^E - \frac{c(T^V)}{2\sqrt{2}u} \right)^2 + u \left[\nabla^E - \frac{c(T^V)}{2\sqrt{2}u}, D^X + TV \right].$$

Then

$$(9.5) \quad B_{u,T}^2 = u^2 A_T^{(0),2} + R_{u,T}.$$

By [4, Theorem 2.5], $R_{u,T}$ is a sum of forms of positive degree in $\Lambda(T_{\mathbf{R}}^*S)$ with values in first order differential operators acting along the fibre X .

For any $s \in S$, the operators $B_{u,T}^2$ and A_T^2 are unbounded operators acting on E_s , with domain the obvious Sobolev spaces of order 2.

Proposition 9.2 — *For any $u > 0, T > 0$,*

$$(9.6) \quad \text{Sp}(B_{u,T}^2) = \text{Sp}(u^2 A_T^{(0),2}).$$

Proof. Take $\lambda \notin \text{Sp}(u^2 A_T^{(0),2})$. Then we have the formal identity

$$(9.7) \quad (\lambda - B_{u,T}^2)^{-1} = \left(\lambda - u^2 A_T^{(0),2} \right)^{-1} + \left(\lambda - u^2 A_T^{(0),2} \right)^{-1} R_{u,T} \left(\lambda - u^2 A_T^{(0),2} \right)^{-1} + \dots$$

the key point in (9.7) being that since $R_{u,T}$ has positive degree in $\Lambda(T_{\mathbf{R}}^*S)$, the expansion contains only a finite number of terms. Since $u^2 A_T^{(0),2}$ is elliptic of order 2, $(\lambda - u^2 A_T^{(0),2})^{-1}$ increases the Sobolev regularity by 2. Since $R_{u,T}$ is of order 1, $(\lambda - B_{u,T}^2)^{-1}$ acts as a bounded operator on the Sobolev space of order 0. Therefore $\lambda \notin \text{Sp}(B_{u,T}^2)$. By exchanging the roles of $B_{u,T}^2$ and $u^2 A_T^{(0),2}$, we find that if $\lambda \notin \text{Sp}(B_{u,T}^2)$, then $\lambda \notin \text{Sp}(u^2 A_T^{(0),2})$. Our Proposition follows. \square

Let $D = \delta \cup \Delta$ be the contour in \mathbf{C}

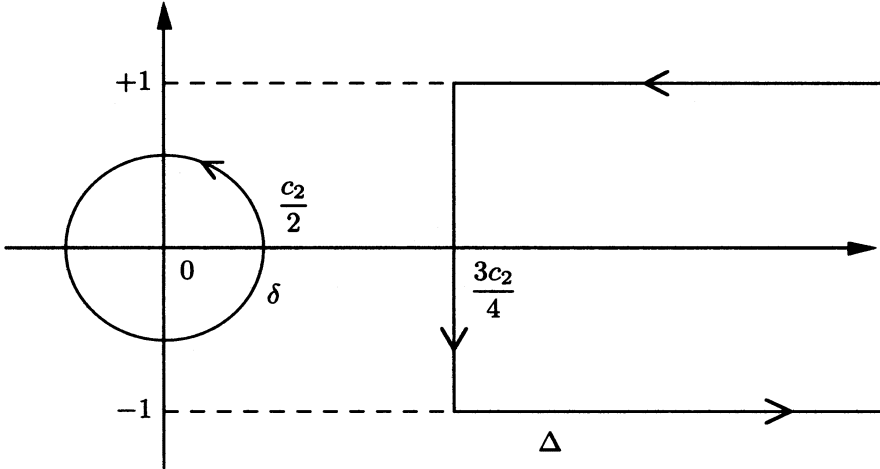

By Theorem 9.1 and Proposition 9.2, it is clear that for $u \geq 1, T \geq T_0$

$$(9.8) \quad \exp(-B_{u,T}^2) = \frac{1}{2\pi i} \int_{\Delta} \frac{\exp(-u^2 \lambda)}{\lambda - \frac{B_{u,T}^2}{u^2}} d\lambda + \frac{1}{2\pi i} \int_{\delta} \frac{\exp(-\lambda)}{\lambda - B_{u,T}^2} d\lambda.$$

9.2 A scaling formula

For $u > 0$, let $\psi_u : \Lambda(T_{\mathbf{R}}^*S) \rightarrow \Lambda(T_{\mathbf{R}}^*S)$ be the map

$$(9.9) \quad \alpha \in \Lambda(T_{\mathbf{R}}^*S) \rightarrow u^{-\text{deg}\alpha} \alpha \in \Lambda(T_{\mathbf{R}}^*S).$$

Then ψ_u acts like $\psi_u \hat{\otimes} 1$ on $\Lambda(T_{\mathbf{R}}^*S) \hat{\otimes} E$.

Proposition 9.3 — For $u > 0, T > 0$, the following identities hold

$$(9.10) \quad \begin{aligned} B_{u,T} &= u\psi_u A_T \psi_u^{-1}, \\ N_{u^2} &= \psi_u N_1^V \psi_u^{-1}, \\ B_{u^2}^W &= u\psi_u B_1^W \psi_u^{-1}, \\ N_{u^2}^W &= \psi_u N_1^W \psi_u^{-1}. \end{aligned}$$

Proof. By (2.31),

$$(9.11) \quad B_{u^2}^V = u\psi_u B_1^V \psi_u^{-1}.$$

Since $B_{u,T} = B_{u^2}^V + uTV$, the first identity in (9.10) follows. The second identity is trivial. The proof of the other identities in (9.10) is similar. \square

Proposition 9.4 — *For $u > 0, T > 0$, the following identities hold*

$$(9.12) \quad \begin{aligned} \text{Tr}_s \left[N_{u^2}^V \frac{1}{2\pi i} \int_{\Delta} \frac{\exp(-u^2\lambda)}{\lambda - \frac{B_{u,T}^2}{u^2}} d\lambda \right] &= \psi_u \text{Tr}_s \left[N_1^V \frac{1}{2\pi i} \int_{\Delta} \frac{\exp(-u^2\lambda)}{\lambda - A_T^2} d\lambda \right], \\ \text{Tr}_s \left[N_{\mathbf{H}} \frac{1}{2\pi i} \int_{\Delta} \frac{\exp(-u^2\lambda)}{\lambda - \frac{B_{u,T}^2}{u^2}} d\lambda \right] &= \psi_u \text{Tr}_s \left[N_{\mathbf{H}} \frac{1}{2\pi i} \int_{\Delta} \frac{\exp(-u^2\lambda)}{\lambda - A_T^2} d\lambda \right]. \end{aligned}$$

Also, for $u > 0$,

$$(9.13) \quad \begin{aligned} \text{Tr}_s \left[N_{u^2}^W \frac{1}{2\pi i} \int_{\Delta} \frac{\exp(-u^2\lambda)}{\lambda - \frac{B_{u^2}^{W,2}}{u^2}} d\lambda \right] &= \psi_u \text{Tr}_s \left[N_1^W \frac{1}{2\pi i} \int_{\Delta} \frac{\exp(-u^2\lambda)}{\lambda - B_1^{W,2}} d\lambda \right], \\ \text{Tr}_s \left[\frac{1}{2\pi i} \int_{\Delta} \frac{\exp(-u^2\lambda)}{\lambda - \frac{B_{u^2}^{W,2}}{u^2}} d\lambda \right] &= \psi_u \text{Tr}_s \left[\frac{1}{2\pi i} \int_{\Delta} \frac{\exp(-u^2\lambda)}{\lambda - B_1^{W,2}} d\lambda \right]. \end{aligned}$$

Proof. Our Proposition follows from Proposition 9.3. \square

9.3 Two intermediate results

In the whole Section, u_0 denotes a fixed positive constant.

Theorem 9.5 — *There exist $\delta \in]0, 1], C > 0$ such that for $u \geq u_0, T \geq T_0$,*

$$(9.14) \quad \begin{aligned} &\left| \text{Tr}_s \left[(N_1^V - N_{\mathbf{H}}) \frac{1}{2\pi i} \int_{\Delta} \frac{\exp(-u^2\lambda)}{\lambda - A_T^2} d\lambda \right] \right. \\ &\quad \left. - \text{Tr}_s \left[N_1^W \frac{1}{2\pi i} \int_{\Delta} \frac{\exp(-u^2\lambda)}{\lambda - B_1^{W,2}} d\lambda \right] \right| \leq \frac{C}{T^\delta}, \\ &\left| \text{Tr}_s \left[N_{\mathbf{H}} \frac{1}{2\pi i} \int_{\Delta} \frac{\exp(-u^2\lambda)}{\lambda - A_T^2} d\lambda \right] - \frac{1}{2} \dim N_{Y/X} \right. \\ &\quad \left. \text{Tr}_s \left[\frac{1}{2\pi i} \int_{\Delta} \frac{\exp(-u^2\lambda)}{\lambda - B_1^{W,2}} d\lambda \right] \right| \leq \frac{C}{T^\delta}. \end{aligned}$$

There exist $c > 0$, $C > 0$ such that for $u \geq u_0$, $T \geq T_0$

$$(9.15) \quad \begin{aligned} \left| \text{Tr}_s \left[N_1^V \frac{1}{2\pi i} \int_{\Delta} \frac{\exp(-u^2 \lambda)}{\lambda - A_T^2} d\lambda \right] \right| &\leq c \exp(-Cu^2), \\ \left| \text{Tr}_s \left[N_{\mathbf{H}} \frac{1}{2\pi i} \int_{\Delta} \frac{\exp(-u^2 \lambda)}{\lambda - A_T^2} d\lambda \right] \right| &\leq c \exp(-Cu^2). \end{aligned}$$

Theorem 9.6 — There exist $\delta \in]0, 1]$, $C > 0$ such that for $u \geq u_0$, $T \geq T_0$,

$$(9.16) \quad \begin{aligned} &\left| \text{Tr}_s \left[(N_{u^2}^V - N_{\mathbf{H}}) \frac{1}{2\pi i} \int_{\delta} \frac{\exp(-\lambda)}{\lambda - B_{u,T}^2} d\lambda \right] - \right. \\ &\quad \left. \text{Tr}_s \left[N_{u^2}^W \frac{1}{2\pi i} \int_{\delta} \frac{\exp(-\lambda)}{\lambda - B_{u^2}^{W,2}} d\lambda \right] \right| \leq \frac{C}{T^{\delta}}, \\ &\left| \text{Tr}_s \left[N_{\mathbf{H}} \frac{1}{2\pi i} \int_{\delta} \frac{\exp(-\lambda)}{\lambda - B_{u,T}^2} d\lambda \right] - \frac{1}{2} \dim N_{Y/X} \right. \\ &\quad \left. \text{Tr}_s \left[\frac{1}{2\pi i} \int_{\delta} \frac{\exp(-\lambda)}{\lambda - B_{u^2}^{W,2}} d\lambda \right] \right| \leq \frac{C}{T^{\delta}}. \end{aligned}$$

There exists $C > 0$ such that for $u \geq u_0$, $T \geq T_0$,

$$(9.17) \quad \begin{aligned} &\left| \left[N_{u^2}^V \frac{1}{2\pi i} \int_{\delta} \frac{\exp(-\lambda)}{\lambda - B_{u,T}^2} d\lambda \right] - \right. \\ &\quad \left. \text{Tr}_s \left[P_T N_{\mathbf{V}}^X P_T \exp(-\nabla_T^{H(X, \xi|_X), 2}) \right] \right| \leq \frac{C}{u}, \\ &\left| \text{Tr}_s \left[N_{\mathbf{H}} \frac{1}{2\pi i} \int_{\delta} \frac{\exp(-\lambda)}{\lambda - B_{u,T}^2} d\lambda \right] \right. \\ &\quad \left. - \text{Tr}_s \left[P_T N_{\mathbf{H}} P_T \exp(-\nabla_T^{H(X, \xi|_X), 2}) \right] \right| \leq \frac{C}{u}. \end{aligned}$$

Proof. The proof of Theorems 9.5 and 9.6 will occupy the remainder of the Chapter. \square

Remark 9.7. Now we show how to derive Theorems 6.5 and 6.6 from Theorems 9.5 and 9.6. If $\alpha \in \Lambda(T_{\mathbf{R}}^* S)$, for $u \geq u_0$,

$$(9.18) \quad |\psi_u \alpha| \leq C |\alpha|.$$

By Proposition 9.4 and Theorems 9.5 and 9.6, and by (9.18), we find that for $u \geq u_0$,

$T \geq T_0$,

$$(9.19) \quad \left| \operatorname{Tr}_s \left[(N_{u^2}^V - N_{\mathbf{H}}) \frac{1}{2\pi i} \int_{\Delta} \frac{\exp(-u^2 \lambda)}{\lambda - \frac{B_{u,T}^2}{u^2}} d\lambda - \operatorname{Tr}_s \left[N_{u^2}^W \frac{1}{2\pi i} \int_{\Delta} \frac{\exp(-u^2 \lambda)}{\lambda - \frac{B_{u^2}^{W,2}}{u^2}} d\lambda \right] \right| \leq \frac{C}{T^\delta}, \right.$$

$$\left. \left| \operatorname{Tr}_s \left[(N_{u^2}^V - N_{\mathbf{H}}) \frac{1}{2\pi i} \int_{\delta} \frac{\exp(-\lambda)}{\lambda - B_{u,T}^2} d\lambda - \operatorname{Tr}_s \left[N_{u^2}^W \frac{1}{2\pi i} \int_{\delta} \frac{\exp(-\lambda)}{\lambda - B_{u^2}^{W,2}} d\lambda \right] \right| \leq \frac{C}{T^\delta} . \right.$$

Using (9.8) and the obvious analogue identity for $B_{u^2}^{W,2}$, we get the first inequality in (6.17). The proof of the second identity in (6.17) is similar. We have thus established Theorem 6.5. Using (9.15) and (9.17), we also obtain Theorem 6.6.

9.4 A formula for $P^{\xi^-} f^\alpha \nabla_{f_\alpha^{H,W}}^\xi V P^{\xi^-} |_W$ and its normal derivative

Theorem 9.8 — *If $Z \in N_{Y/X,R}$, then*

$$(9.20) \quad \begin{aligned} P^{\xi^-} f^\alpha \nabla_{f_\alpha^{H,W}}^\xi V P^{\xi^-} |_W &= 0, \\ P^{\xi^-} \widetilde{\nabla}_Z^\xi \nabla_{f_\alpha^{H,W}}^\xi V P^{\xi^-} |_W &= 0. \end{aligned}$$

Proof. Since $V|_{\overline{W}} = 0$, $\widetilde{\nabla}_{f_\alpha^{H,W}}^\xi V|_{\overline{W}} = 0$. By proceeding as in (7.21), we obtain

$$(9.21) \quad P^{\xi^-} f^\alpha \nabla_{f_\alpha^{H,W}}^\xi V P^{\xi^-} |_{\overline{W}} = f_\alpha \widetilde{\nabla}_{f_\alpha^{H,W}}^\xi V|_{\overline{W}} = 0.$$

To prove the second identity, we proceed as in the proof of [19, Theorem 13.19, eq. (13.92)]. Clearly, on $\mathcal{U}_{\varepsilon_0}$

$$(9.22) \quad P^{\xi^-} \nabla_{f_\alpha^{H,W}}^\xi V P^{\xi^-} = P^{\xi^-} \widetilde{\nabla}_{f_\alpha^{H,W}}^\xi V P^{\xi^-},$$

and so

$$(9.23) \quad P^{\xi^-} \widetilde{\nabla}_Z^\xi \nabla_{f_\alpha^{H,W}}^\xi V P^{\xi^-} = P^{\xi^-} \widetilde{\nabla}_Z^\xi \widetilde{\nabla}_{f_\alpha^{H,W}}^\xi V P^{\xi^-}.$$

Moreover

$$(9.24) \quad \widetilde{\nabla}_Z^\xi \widetilde{\nabla}_{f_\alpha^{H,W}}^\xi V = \widetilde{\nabla}_{f_\alpha^{H,W}}^\xi \widetilde{\nabla}_Z^\xi V - \widetilde{\nabla}_{[f_\alpha^{H,W}, Z]}^\xi V + \left[(\widetilde{\nabla}^\xi)^2(Z, f_\alpha^{H,W}), V \right].$$

Using Proposition 7.8 and (9.24), we obtain

$$(9.25) \quad P^{\xi^-} \tilde{\nabla}_Z^\xi \nabla_{f_\alpha^{H,W}}^\xi V P^{\xi^-} |W = P^{\xi^-} \frac{\sqrt{-1}}{\sqrt{2}} \hat{c} \left(\nabla_{f_\alpha^{H,W}}^{N_{Y/X}} Z - P^{N_{Y/X}} [f_\alpha^{H,W}, Z] \right).$$

By Proposition 7.2,

$$(9.26) \quad \nabla_{f_\alpha^{H,W}}^{N_{Y/X}} Z = P^{N_{Y/X}} \nabla_{f_\alpha^{H,W}}^{TX} Z.$$

Using (1.3), (7.25), (9.26), we get

$$(9.27) \quad \nabla_{f_\alpha^{H,W}}^{N_{Y/X}} Z - P^{N_{Y/X}} [f_\alpha^{H,W}, Z] = P^{N_{Y/X}} \left(\nabla_Z^{TV} f_\alpha^{H,W} + T^V(f_\alpha^{H,W}, Z) \right) = 0.$$

From (9.25), (9.27), we get the second identity in (9.20). □

9.5 An embedding of F in E

Clearly

$$(9.28) \quad \begin{aligned} & \text{Tr}_s \left[(N_1^V - N_{\mathbf{H}}) \frac{1}{2\pi i} \int_{\Delta} \frac{\exp(-u^2 \lambda)}{\lambda - A_T^2} d\lambda \right] = \\ & \text{Tr}_s \left[(\tilde{N}_1^V - N_{\mathbf{H}}) \frac{1}{2\pi i} \int_{\Delta} \frac{\exp(-u^2 \lambda)}{\lambda - \tilde{A}_{1,T}^2} d\lambda \right], \\ & \text{Tr}_s \left[N_{\mathbf{H}} \frac{1}{2\pi i} \int_{\Delta} \frac{\exp(-u^2 \lambda)}{\lambda - A_T^2} d\lambda \right] = \\ & \text{Tr}_s \left[N_{\mathbf{H}} \frac{1}{2\pi i} \int_{\Delta} \frac{\exp(-u^2 \lambda)}{\lambda - \tilde{A}_{1,T}^2} d\lambda \right]. \end{aligned}$$

So in our proof of Theorem 9.5, we may as well introduce \sim in the left-hand sides of (9.14), (9.15).

Definition 9.9. For $s \in S$, $\mu \in \mathbf{R}$, let E_s^μ (resp. \mathbf{E}_s^μ , resp. F_s^μ) be the set of sections of $\Lambda(T^{*(0,1)} X) \hat{\otimes} \xi$ over X_s (resp. of $\pi^* ((\Lambda(T^{*(0,1)} X) \hat{\otimes} \xi)|_W)$ over $N_{Y/X, \mathbf{R}}|_{Y_s}$, resp. of $\Lambda(T^{*(0,1)} Y) \otimes \eta$ over Y_s) which lie in the μ^{th} Sobolev space, and let $\| \cdot \|_{E_s^\mu}$ (resp. $\| \cdot \|_{\mathbf{E}_s^\mu}$, resp. $\| \cdot \|_{F_s^\mu}$) be the corresponding Sobolev norm. We will assume that $\| \cdot \|_{E_s^0}$ (resp. $\| \cdot \|_{\mathbf{E}_s^0}$) is associated to the Hermitian product (2.22) (resp. (8.2)).

Recall that $\varepsilon_0 > 0$ was defined in Section 7.3. We take $\varepsilon \in]0, \frac{\varepsilon_0}{4}]$. In the sequel the constants in our estimates depend on ε . In Theorem 9.14, we will choose ε small enough so that the corresponding estimates hold. Otherwise ε can be assumed to be fixed.

Let $\gamma: \mathbf{R} \rightarrow [0, 1]$ be taken as in (7.29). If $Z \in N_{Y/X, \mathbf{R}}$, set

$$(9.29) \quad \rho(Z) = \gamma \left(\frac{|Z|}{\varepsilon} \right).$$

Let α_T be the locally constant function on W

$$(9.30) \quad \alpha_T = \int_{N_{Y/X}} \exp(-T|Z|^2) \rho^2(Z) \frac{dv_{N_{Y/X}}}{(2\pi)^{\dim N_{Y/X}}}.$$

Now we follow [19, Section 9 a)].

Definition 9.10. For $\mu \geq 0$, $T > 0$, let I_T be the linear map

$$(9.31) \quad \sigma \in F^\mu \rightarrow I_T \sigma(y, Z) = (2^{\dim N_{Y/X}} \alpha_T)^{-1/2} \rho(Z) \exp\left(\theta - \frac{T|Z|^2}{2}\right) \sigma(y) \in \mathbf{E}^\mu.$$

Let \mathbf{E}_T^μ be the image of F^μ in \mathbf{E}^μ by I_T . Then I_T is an isometric embedding of F^0 into \mathbf{E}^0 .

Let $\mathbf{E}_T^{0,\perp}$ be the orthogonal space to \mathbf{E}_T^0 in \mathbf{E}^0 , let p_T, p_T^\perp be the orthogonal projection operators from \mathbf{E}^0 on $\mathbf{E}_T^0, \mathbf{E}_T^{0,\perp}$ respectively. Recall that q is the orthogonal projection operator from $(\Lambda(T^{*(0,1)}X) \widehat{\otimes} \xi)|_W$ on $\Lambda(T^{*(0,1)}Y) \otimes \{\beta\} \otimes \eta$.

We recall a result of [19, Proposition 9.2].

Proposition 9.11 — *If $s \in \mathbf{E}^0$, if $y \in W$, $Z \in N_{Y/X, \mathbf{R}, y}$,*

$$(9.32) \quad p_T s(y, Z) = \frac{\rho(Z)}{\alpha_T} \exp\left(-\frac{T|Z|^2}{2}\right) q \int_{N_{Y/X, v}} \rho(Z') \exp\left(-\frac{T|Z'|^2}{2}\right) s(y, Z') \frac{dv_{N_{Y/X}}(Z')}{(2\pi)^{\dim N_{Y/X}}}.$$

If $\sigma \in F^\mu$, we can consider $k^{-1/2} I_T \sigma$ as an element of E^μ .

Definition 9.12. For $\mu \geq 0$, $T > 0$, let J_T be the linear map

$$(9.33) \quad \sigma \in F^\mu \rightarrow J_T \sigma = k^{-1/2} I_T \sigma \in E^\mu.$$

Then J_T is an isometric embedding from F^0 into E^0 . Let E_T^μ be the image of F^μ in E^μ . Let $E_T^{0,\perp}$ be the orthogonal bundle to E_T^0 in E^0 .

For $\mu \geq 0$, set

$$(9.34) \quad E_T^{\mu,\perp} = E^\mu \cap E_T^{0,\perp}.$$

Let $\bar{p}_T, \bar{p}_T^\perp$ be the orthogonal projection operators from E^0 on $E_T^0, E_T^{0,\perp}$. By [19, Proposition 9.5],

$$(9.35) \quad \bar{p}_T = k^{-1/2} p_T k^{1/2}, \quad \bar{p}_T^\perp = k^{-1/2} p_T^\perp k^{1/2}.$$

9.6 A Sobolev norm on E^1

Let $e_1, \dots, e_{2\ell}$ be a locally defined smooth orthogonal basis of $T_{\mathbf{R}}X$. We assume that on W , $e_1, \dots, e_{2\ell'}$ is an orthonormal basis of $T_{\mathbf{R}}Y$ and $e_{2\ell'+1}, \dots, e_{2\ell}$ is an orthonormal basis of $N_{Y/X, \mathbf{R}}$.

Recall that if $U \in T_{\mathbf{R}}W$, $U^H \in T_{\mathbf{R}}^H N_{Y/X}$ was defined in Section 8.2. In particular for $1 \leq i \leq 2\ell'$, $e_{i|W} \in T_{\mathbf{R}}Y$ and so $e_{i|W}^H \in T_{\mathbf{R}}^H N_{Y/X}$. Using the identification $B_{\varepsilon_0} \simeq \mathcal{O}_{\varepsilon_0}$ described in Section 7.3, $e_{i|W}^H$ is a locally defined vector field on $\mathcal{O}_{\varepsilon_0}$.

If $s \in E$, put

$$(9.36) \quad \begin{aligned} |s|_0 &= \|s\|_{E^0} , \\ \langle s, s' \rangle_0 &= \langle s, s' \rangle_{E^0} . \end{aligned}$$

Definition 9.13. For $T \geq 1$, $s \in E$, set

$$(9.37) \quad \begin{aligned} |s|_{T,1}^2 &= |\bar{p}_T s|_0^2 + T |\bar{p}_T^\perp s|_0^2 + T^2 |V \bar{p}_T^\perp s|_0^2 \\ &\quad + \sum_1^{2\ell} \left| \nabla_{e_i}^{\Lambda(T^{*(0,1)}X)} \widehat{\otimes} \xi \bar{p}_T^\perp s \right|_0^2 + \\ &\quad \sum_1^{2\ell'} \left| \widetilde{\nabla}_{\rho(\frac{\xi}{2}) e_{i|W}^H} (\Lambda(T^{*(0,1)}X) \widehat{\otimes} \xi) |_{W} \bar{p}_T s \right|_0^2 . \end{aligned}$$

Then (9.37) defines a Hilbert norm on E^1 . Also $(E^1, | \cdot |_{T,1})$ is continuously embedded in $(E^0, | \cdot |_0)$. We identify E^0 to its antidual by $\langle \cdot, \cdot \rangle_0$. Then we can identify E^{-1} to the antidual of E^1 . Let $| \cdot |_{T,-1}$ be the norm on E^{-1} associated to $| \cdot |_{T,1}$. Then we have the continuous dense embeddings with norms smaller than 1,

$$(9.38) \quad \mathbf{E}^1 \rightarrow \mathbf{E}^0 \rightarrow \mathbf{E}^{-1} .$$

For convenience, we introduce a metric g^{TS} on TS . Then the definition of $|s|_0, |s|_{T,1}$ obviously extends to $\Lambda(T_{\mathbf{R}}^* S) \widehat{\otimes} E$.

Put

$$(9.39) \quad \widetilde{A}_T = \widetilde{A}_{1,T} .$$

Let $\widetilde{A}_T^{(0)}$ (resp. $\widetilde{A}_T^{(>0)}$) be the piece of \widetilde{A}_T which has degree 0 (resp. positive degree) in $\Lambda(T_{\mathbf{R}}^* S)$. Then

$$(9.40) \quad \widetilde{A}_T = \widetilde{A}_T^{(0)} + \widetilde{A}_T^{(>0)} .$$

By (3.15), (4.1), (6.9),

$$(9.41) \quad \widetilde{A}_T^{(0)} = D^X + TV .$$

Set

$$(9.42) \quad \tilde{R}_T = [\tilde{A}_T^{(0)}, \tilde{A}^{(>0)}] + \tilde{A}^{(>0),2}.$$

Then \tilde{R}_T is a first order differential operator and moreover

$$(9.43) \quad \tilde{A}_T^2 = \tilde{A}_T^{(0),2} + \tilde{R}_T.$$

Theorem 9.14 — *If $\varepsilon \in]0, \varepsilon_0/4[$ is small enough, there exist constants $C_1 > 0, C_2 > 0, C_3 > 0$ such that for $T \geq 1, s, s' \in \Lambda(T\mathbf{R}^*S) \hat{\otimes} E$,*

$$(9.44) \quad \begin{aligned} & \left| \tilde{A}_T^{(0)} s \right|_0^2 \geq C_1 |s|_{T,1}^2 - C_2 |s|_0^2, \\ & \left| \langle \tilde{A}_T^{(0)} s, \tilde{A}_T^{(0)} s' \rangle_0 \right| \leq C |s|_{T,1} |s'|_{T,1}, \\ & \left| \langle \tilde{R}_T s, s' \rangle_0 \right| \leq C_3 (|s|_{T,1} |s'|_0 + |s|_0 |s'|_{T,1}). \end{aligned}$$

Proof. In the whole proof, $C, C' \dots$ are positive constants, which may vary from line to line.

To establish the first inequality in (9.44), we may as well assume that $s \in E$. If $s \in E$, then

$$(9.45) \quad \begin{aligned} \left| \tilde{A}_T^{(0)} s \right|_0^2 &= \left| \bar{p}_T \tilde{A}_T^{(0)} s \right|_0^2 + \left| \bar{p}_T^\perp \tilde{A}_T^{(0)} s \right|_0^2 \geq \\ & \frac{1}{2} \left| \bar{p}_T \tilde{A}_T^{(0)} \bar{p}_T s \right|_0^2 + \frac{1}{2} \left| \bar{p}_T^\perp \tilde{A}_T^{(0)} \bar{p}_T^\perp s \right|_0^2 \\ & \quad - \left| \bar{p}_T \tilde{A}_T^{(0)} \bar{p}_T^\perp s \right|_0^2 - \left| \bar{p}_T^\perp \tilde{A}_T^{(0)} \bar{p}_T s \right|_0^2. \end{aligned}$$

□

By [19, Theorem 9.8], since J_T is an isometry and since S is compact, there exist $C > 0, C' > 0$ such that for $T \geq 1, \sigma \in F$,

$$(9.46) \quad \left| \bar{p}_T \tilde{A}_T^{(0)} \bar{p}_T J_T \sigma \right|_0 \geq C \|\sigma\|_{F^1} - C' \|\sigma\|_{F^0}.$$

From (9.46), we deduce that

$$(9.47) \quad \left| \bar{p}_T \tilde{A}_T^{(0)} \bar{p}_T s \right|_0 \geq C \|J_T^{-1} \bar{p}_T s\|_{F^1} - C' |\bar{p}_T s|_0.$$

By (9.32), (9.35), if $\sigma \in F$,

$$(9.48) \quad \sum_1^{2\ell} \left| \left\langle \tilde{\nabla}^{(\Lambda(T^{*(0,1)}X) \hat{\otimes} \xi)} \Big|_{\rho(\frac{X}{2}) e_{i|w}^H} \right\rangle_w J_T \sigma \right|_0 \leq C \|\sigma\|_{F^1}.$$

From (9.48), we obtain

$$(9.49) \quad \sum_1^{2\ell'} \left| {}_0\tilde{\nabla}_{\rho(\frac{\xi}{2})e_{i|w}^H}(\Lambda(T^{*(0,1)}X)\hat{\otimes}\xi)|_w \bar{p}_T s \right|_0 \leq C \|J_T^{-1} \bar{p}_T s\|_{F^1}.$$

Using (9.47), (9.49), we get

$$(9.50) \quad \left| \bar{p}_T \tilde{A}_T^{(0)} \bar{p}_T s \right|_0 \geq C \sum_1^{2\ell'} \left| {}_0\tilde{\nabla}_{\rho(\frac{\xi}{2})e_{i|w}^H}(\Lambda(T^{*(0,1)}X)\hat{\otimes}\xi)|_w \bar{p}_T s \right|_0 - C' |\bar{p}_T s|_0.$$

If $s \in E$, on $\mathcal{U}_{\varepsilon_0}$, we can write $s = s^+ + s^-$, $s^\pm \in \Lambda(T^{*(0,1)}X) \hat{\otimes} \xi^\pm$. By [19, Proposition 8.14], if s is supported in $\mathcal{U}_{\varepsilon_0}$,

$$(9.51) \quad C(|s^+| + |Z| |s^-|) \leq |Vs| \leq C'(|s^+| + |Z| |s^-|).$$

By [19, eq. (9.52), (9.87)] and by (9.51), if $\varepsilon \in]0, \varepsilon_0/4]$ is small enough, if $s \in E_{1,T}^\perp$ is supported in $\mathcal{U}_{2\varepsilon}$, then

$$(9.52) \quad \left| \tilde{A}_T^{(0)} s \right|_0^2 \geq C \|s\|_{E^1}^2 + C'T^2 |Vs|_0^2 + C''T |s|_0^2 - C''' |s|_0^2.$$

By [19, eq. (9.93)], if $s \in E$ vanishes on \mathcal{U}_ε , then

$$(9.53) \quad \left| \tilde{A}_T^{(0)} s \right|_0^2 \geq C \|s\|_{E^1}^2 + C'T^2 |s|_0^2 - C''' |s|_0^2.$$

Using (9.52), (9.53) and proceeding as in [19, p. 115, 116] and specially [19, eq. (9.97)-(9.99)], we find that if $s \in E_T^{1,\perp}$,

$$(9.54) \quad \left| \tilde{A}_T^{(0)} s \right|_0^2 \geq C \|s\|_{E^1}^2 + C'T^2 |Vs|_0^2 + C''T |s|_0^2 - C''' |s|_0^2.$$

By [19, Theorem 9.10],

$$(9.55) \quad \begin{aligned} \left| \bar{p}_T^\perp \tilde{A}_T^{(0)} \bar{p}_T s \right|_0 &\leq C \left(\frac{\|\bar{p}_T s\|_{E^1}}{\sqrt{T}} + |\bar{p}_T s|_0 \right), \\ \left| \bar{p}_T \tilde{A}_T^{(0)} \bar{p}_T^\perp s \right|_0 &\leq C \left(\frac{\|\bar{p}_T^\perp s\|_{E^1}}{\sqrt{T}} + |\bar{p}_T^\perp s|_0 \right). \end{aligned}$$

Using (9.54) and the second inequality in (9.55), for $T \geq 1$ large enough,

$$(9.56) \quad \begin{aligned} \left| \bar{p}_T^\perp \tilde{A}_T^{(0)} \bar{p}_T^\perp s \right|_0^2 &\geq C \|\bar{p}_T^\perp s\|_{E^1}^2 + C'T^2 |V\bar{p}_T^\perp s|_0^2 \\ &\quad + C''T |\bar{p}_T^\perp s|_0^2 - C''' |\bar{p}_T^\perp s|_0^2. \end{aligned}$$

By (9.32), (9.35)

$$(9.57) \quad \|\bar{p}_T s\|_{E^1} \leq C \sum_1^{2\ell'} \left| {}_0\tilde{\nabla}_{\rho(Z/2)e_{i|w}^H}^{(\Lambda(T^{*(0,1)}X)\widehat{\otimes}\xi)|_w} \bar{p}_T s \right|_0 + C' \sqrt{T} |\bar{p}_T s|_0 .$$

Using (9.45), (9.50), (9.55)-(9.57), for $T \geq 1$ large enough, we obtain the first inequality in (9.44). Of course small values of $T \geq 1$ do not matter here.

Now we prove the second inequality in (9.44). Clearly

$$(9.58) \quad \left| \tilde{A}_T^{(0)} s \right|_0 \leq \left| \tilde{A}_T^{(0)} \bar{p}_T s \right|_0 + \left| \tilde{A}_T^{(0)} \bar{p}_T^\perp s \right|_0 .$$

By (9.41),

$$(9.59) \quad \left| \tilde{A}_T^{(0)} \bar{p}_T^\perp s \right|_0 \leq C (\|\bar{p}_T^\perp s\|_{E^1} + T |V \bar{p}_T^\perp s|_0) .$$

By [19, Theorem 9.8],

$$(9.60) \quad \left| \bar{p}_T \tilde{A}_T^{(0)} \bar{p}_T s \right|_0 \leq C \|J_T^{-1} \bar{p}_T s\|_{F^1} .$$

Using (9.32), it is elementary to verify that

$$(9.61) \quad \|J_T^{-1} \bar{p}_T s\|_{F^1} \leq \sum_1^{2\ell'} \left| {}_0\tilde{\nabla}_{\rho(Z/2)e_{i|w}^H}^{(\Lambda(T^{*(0,1)}X)\widehat{\otimes}\xi)|_w} \bar{p}_T s \right|_0 + C' |\bar{p}_T s|_0 .$$

From (9.55), (9.57)-(9.61), we get the second inequality in (9.44).

Now we prove the third inequality in (9.44). Put

$$(9.62) \quad H = [D^X, \tilde{A}^{(>0)}] + \tilde{A}^{(>0),2} .$$

Then H is a fibrewise first order differential operator, and moreover

$$(9.63) \quad \tilde{R}_T = H + T [V, \tilde{A}^{(>0)}] .$$

Clearly if $s, s' \in \Lambda(T_{\mathbb{R}}^* S) \widehat{\otimes} E$,

$$(9.64) \quad |\langle Hs, s' \rangle_0| \leq C (|s|_{T,1} |s'|_0 + |s|_0 |s'|_{T,1}) + |\langle H\bar{p}_T s, \bar{p}_T s' \rangle_0| .$$

Observe that

$$(9.65) \quad \begin{aligned} & \int_{N_{Y/X}} T Z^i \rho^2(Z) \exp(-T |Z|^2) \frac{dv_{N_{Y/X}}(Z)}{(2\pi)^{\dim N_{Y/X}}} = \\ & \int_{N_{Y/X}} T Z^i (\rho^2(Z) - 1) \exp(-T |Z|^2) \frac{dv_{N_{Y/X}}(Z)}{(2\pi)^{\dim N_{Y/X}}} = \mathcal{O}(e^{-cT}) \\ & \int_{N_{Y/X}} \frac{(T |Z|^2)^p \rho^2(Z)}{\alpha_T} \exp(-T |Z|^2) \frac{dv_{N_{Y/X}}(Z)}{(2\pi)^{\dim N_{Y/X}}} = \mathcal{O}(1), \quad p > 0 \end{aligned}$$

Moreover, if U is a smooth section of $T_{\mathbf{R}}X$, using (9.32) , (9.65) we get

$$(9.66) \quad \left| |Z| \nabla_U^{\Lambda(T^{*(0,1)}X) \otimes \xi} \bar{p}_T s \right|_0 \leq C \left(\sum_1^{2\ell'} \left| {}_0 \tilde{\nabla}_{\rho(Z/2) e_{i|w}^H} (\Lambda(T^{*(0,1)}X) \otimes \xi) |w \bar{p}_T s \right|_0 + |\bar{p}_T s|_0 \right).$$

By (9.65), (9.66),

$$(9.67) \quad |\langle H \bar{p}_T s, \bar{p}_T s' \rangle_0| \leq C \left(|s|_{T,1} |s'|_0 + |s|_0 |s'|_{T,1} \right).$$

Also

$$(9.68) \quad \left[V, \tilde{A}^{(>0)} \right] = f^\alpha \nabla_{f_\alpha^{H,w}}^\xi V.$$

By (9.20),

$$(9.69) \quad P^{\xi^-} \nabla_{f_\alpha^{H,w}}^\xi V P^{\xi^-} = \mathcal{O}(|Z|^2).$$

By (9.37), (9.51), (9.69)

$$(9.70) \quad \left| \left\langle T f^\alpha \nabla_{f_\alpha^{H,w}}^\xi V s, s' \right\rangle_0 \right| \leq C \left(|s|_{T,1} |s'|_0 + |s|_0 |s'|_{T,1} + T \left| \left\langle f^\alpha \nabla_{f_\alpha^{H,w}}^\xi V \bar{p}_T s, \bar{p}_T s' \right\rangle_0 \right| \right).$$

Using (9.20), (9.65), we get

$$(9.71) \quad T \left| \left\langle f^\alpha \nabla_{f_\alpha^{H,w}}^\xi V \bar{p}_T s, \bar{p}_T s' \right\rangle_0 \right| \leq C |\bar{p}_T s|_0 |\bar{p}_T s'|_0.$$

From (9.69), (9.71), we obtain

$$(9.72) \quad \left| \left\langle T f^\alpha \nabla_{f_\alpha^{H,w}}^\xi V s, s' \right\rangle_0 \right| \leq C \left(|s|_{T,1} |s'|_0 + |s|_0 |s'|_{T,1} \right).$$

From (9.62)-(9.64) and from (9.72), we get the third inequality in (9.44). The proof of our Theorem is completed. \square

9.7 Estimates on the resolvent of \tilde{A}_T^2

Now we fix $\varepsilon > 0$ as in Theorem 9.14.

If $A \in \mathcal{L}(E^0, E^0)$ (resp. $A \in \mathcal{L}(E^{-1}, E^1)$), let $\|A\|^{0,0}$ (resp. $\|A\|_T^{-1,1}$) be the norm of A with respect to the norm $|\cdot|_0$ (resp. the norms $|\cdot|_{T,-1}, |\cdot|_{T,1}$).

Theorem 9.15 — *There exist $T_0 \geq 1, C > 0, p \in \mathbf{N}$, such that for $T > T_0, \lambda \in \Delta$, the resolvent $(\lambda - \tilde{A}_T^2)^{-1}$ is such that*

$$(9.73) \quad \left\| (\lambda - \tilde{A}_T^2)^{-1} \right\|_T^{-1,1} \leq C(1 + |\lambda|)^p.$$

Proof. Recall that $\tilde{A}_T^{(0)} = D^X + TV$. For $\delta > 0, A > 0$ set

$$(9.74) \quad U = \{ \lambda \in \mathbf{C}, \operatorname{Re}(\lambda) \leq \delta \operatorname{Im}^2(\lambda) - A \} .$$

Using the first two inequalities in (9.44), and by proceeding as in [19, Theorems 11.26 and 11.27], we find that if δ is small enough, and A is large enough, for $T \geq 1, \lambda \in U$,

$$(9.75) \quad \begin{aligned} \left\| (\lambda - \tilde{A}_T^{(0),2})^{-1} \right\|^{0,0} &\leq C, \\ \left\| (\lambda - \tilde{A}_T^{(0),2})^{-1} \right\|_T^{-1,1} &\leq C(1 + |\lambda|)^2. \end{aligned}$$

□

Take $\lambda \in \Delta$. By Theorem 9.1, for $T \geq T_0, (\lambda - \tilde{A}_T^{(0),2})^{-1}$ exists and moreover

$$(9.76) \quad \left\| (\lambda - \tilde{A}_T^{(0),2})^{-1} \right\|^{0,0} \leq C.$$

If $\lambda_0 \in U, \lambda \in \Delta, T \geq T_0$, then

$$(9.77) \quad (\lambda - \tilde{A}_T^{(0),2})^{-1} = (\lambda_0 - \tilde{A}_T^{(0),2})^{-1} + (\lambda - \tilde{A}_T^{(0),2})^{-1}(\lambda_0 - \lambda)(\lambda_0 - \tilde{A}_T^{(0),2})^{-1}.$$

From (9.75)-(9.77), using obvious notations, we get

$$(9.78) \quad \left\| (\lambda - \tilde{A}_T^{(0),2})^{-1} \right\|_T^{-1,0} \leq C(1 + |\lambda|).$$

Also

$$(9.79) \quad (\lambda - \tilde{A}_T^{(0),2})^{-1} = (\lambda_0 - \tilde{A}_T^{(0),2})^{-1} + (\lambda_0 - \tilde{A}_T^{(0),2})^{-1}(\lambda_0 - \lambda)(\lambda - \tilde{A}_T^{(0),2})^{-1}.$$

By (9.75), (9.78), (9.79), we obtain

$$(9.80) \quad \left\| (\lambda - \tilde{A}_T^{(0),2})^{-1} \right\|_T^{-1,1} \leq C(1 + |\lambda|)^2.$$

Moreover, if $\lambda \in \Delta$, then

$$(9.81) \quad (\lambda - \tilde{A}_T^2)^{-1} = (\lambda - \tilde{A}_T^{(0),2})^{-1} + (\lambda - \tilde{A}_T^{(0),2})^{-1} \tilde{R}_T (\lambda - \tilde{A}_T^{(0),2})^{-1} \\ + \dots$$

and the expansion terminates after a finite numbers of terms. By Theorem 9.14,

$$(9.82) \quad \left\| \tilde{R}_T \right\|_T^{1,-1} \leq C.$$

Using (9.80)-(9.82), we get (9.73). The proof of our Theorem is completed. □

9.8 Regularizing properties of the resolvent of \tilde{A}_T^2

Since W is compact, there exist a finite family of smooth functions f_1, \dots, f_q on V with values in $[0, 1]$, such that

$$(9.83) \quad W = \bigcap_{j=1}^q \{x \in V, f_j(x) = 0\},$$

and that on W , df_1, \dots, df_q span $N_{Y/X, \mathbf{R}}^*$.

Similarly, there exists a finite family of smooth sections U_1, \dots, U_r of $T_{\mathbf{R}}X$ (resp. U'_1, \dots, U'_r of $T_{\mathbf{R}}Y$) such that for any $x \in V$ (resp. $y \in W$), $U_1(x), \dots, U_r(x)$ (resp. $U'_1(y), \dots, U'_r(y)$) spans $(T_{\mathbf{R}}X)_x$ (resp. $(T_{\mathbf{R}}Y)_y$).

Definition 9.16. For $T \geq 1$, let \mathfrak{Q}_T be the family of operators acting on E

$$(9.84) \quad \mathfrak{Q}_T = \left\{ \nabla_{(1-\rho(Z/2))U_i}^{\Lambda(T^{*(0,1)}X) \hat{\otimes} \xi}, \frac{1}{\sqrt{T}} \bar{p}_T^{\perp 0} \tilde{\nabla}_{\rho(Z/2)U_i}^{\Lambda(T^{*(0,1)}X) \hat{\otimes} \xi}|_W \bar{p}_T^{\perp 1}, \right. \\ \left. 0 \tilde{\nabla}_{\rho(Z/2)U_i^H}^{\Lambda(T^{*(0,1)}X) \hat{\otimes} \xi}|_W, \sqrt{T} \bar{p}_T^{\perp 1} f_j \bar{p}_T^{\perp 1} \right\}.$$

For $k \in \mathbf{N}$, let Q_T^k be the family of operators Q acting on E which can be written in the form

$$(9.85) \quad Q = Q_1 \dots Q_k, \quad Q \in \mathfrak{Q}_T.$$

If $k \in \mathbf{N}$, we equip the Sobolev fibres E^k with the Hilbert norm $\| \cdot \|_{T,k}$ such that if $s \in E$,

$$(9.86) \quad \|s\|_{T,k}^2 = \sum_{\ell=0}^k \sum_{Q \in \mathfrak{Q}_T^\ell} |Qs|_{T,0}^2.$$

Theorem 9.17 — Take $k \in \mathbf{N}$. There exists $C_k > 0$ such that for $T \geq 1$, $Q_1, \dots, Q_k \in \mathfrak{Q}_T$, $s, s' \in \Lambda(T_{\mathbf{R}}^*S) \hat{\otimes} E$,

$$(9.87) \quad \left| \left\langle \left[Q_1, \left[Q_2, \dots \left[Q_k, \tilde{A}_T^2 \right] \right] \right] s, s' \right\rangle_0 \right| \leq C_k |s|_{T,1} |s'|_{T,1}.$$

Proof. First, we consider the case when $k = 1$.

a) The case where $Q = \nabla_{(1-\rho(Z/2))U_i}^{\Lambda(T^{*(0,1)}X) \hat{\otimes} \xi}$.

Observe that $\rho(Z/2) = 1$ for $|Z| \leq \varepsilon$, $\rho(Z) = 0$ for $|Z| \geq 2\varepsilon$. In particular, if $\rho(Z) > 0$, then $1 - \rho(Z/2) = 0$. Also, $[D^X, V] = \frac{1}{\sqrt{2}} \sum_1^{2\ell} c(e_i) \nabla_{e_i}^\xi V$ is of order 0. One

then finds easily that (9.87) holds

b) The case where $Q = \frac{1}{\sqrt{T}} \bar{p}_T^{\perp 0} \tilde{\nabla}_{\rho(Z/2)U_i}^{\Lambda(T^{*(0,1)}X) \hat{\otimes} \xi}|_W \bar{p}_T^{\perp 1}$.

The proof of the corresponding estimate is local on W . By [19, Theorem 13.30], we get

$$(9.88) \quad \left| \left\langle \left[Q, \tilde{A}_T^{(0),2} \right] s, s' \right\rangle_0 \right| \leq C |s|_{T,1} |s'|_{T,1} .$$

Note that in [19], some special properties of the operators Q of [19, Section 13] are used, say in [19, eq. (13.203)], but the corresponding estimates still hold, by replacing these Q 's by our Q 's.

Now we will prove that

$$(9.89) \quad \left| \left\langle \left[Q, \tilde{R}_T \right] s, s' \right\rangle_0 \right| \leq C |s|_{T,1} |s'|_{T,1} .$$

Note that if s and s' lie in $\Lambda(T_{\mathbf{R}}^*S) \hat{\otimes} E_T^1$, then

$$(9.90) \quad \left\langle \left[Q, \tilde{R}_T \right] s, s' \right\rangle_0 = 0 .$$

To establish (9.89), we only need to consider the case where s and s' lie in $\Lambda(T_{\mathbf{R}}^*S) \hat{\otimes} E_T^1$ or $\Lambda(T_{\mathbf{R}}^*S) \hat{\otimes} E_T^{1,\perp}$ and do not lie both in $\Lambda(T_{\mathbf{R}}^*S) \hat{\otimes} E_T^1$.

We use the notation of (9.62), (9.63). As we saw before, H is a first order differential order operator acting fibrewise. If $P = {}_0\tilde{\nabla}_{\rho(Z/2)U_i}^{\Lambda(T^{*(0,1)}X) \hat{\otimes} \xi}|_W$,

$$(9.91) \quad Q = \frac{1}{\sqrt{T}} (P + \bar{p}_T P \bar{p}_T - \bar{p}_T P - P \bar{p}_T) .$$

From (9.32), (9.91), we find that if s, s' are taken as indicated before,

$$(9.92) \quad \left| \left\langle [Q, H] s, s' \right\rangle_0 \right| \leq C |s|_{T,1} |s'|_{T,1} .$$

By (9.20), we find that near W ,

$$(9.93) \quad P^{\xi^-} f^\alpha \nabla_{f_\alpha^{H,W}}^\xi V P^{\xi^-} = \mathcal{O}(|Z|^2) .$$

Using (9.32), (9.91) and (9.93), we obtain

$$(9.94) \quad \left| \left\langle \left[Q, T f^\alpha \nabla_{f_\alpha^{H,W}}^\xi V \right] s, s' \right\rangle_0 \right| \leq C |s|_{T,1} |s'|_{T,1} .$$

From (9.64), (9.92), (9.94), we get (9.89). Therefore, we have proved (9.89) for this choice of Q .

c) The case where $Q = {}_0\tilde{\nabla}_{\rho(Z/2)U_i^{H'}}^{\Lambda(T^{*(0,1)}X) \hat{\otimes} \xi}|_W$.

By [19, Theorem 13.30], we find that

$$(9.95) \quad \left| \left\langle \left[Q, \tilde{A}_T^{(0),2} \right] s, s' \right\rangle_0 \right| \leq C |s|_{T,1} |s'|_{T,1} .$$

Also $[Q, H]$ is a first order differential operator acting fibrewise. Using (9.65), (9.66), we find easily that it verifies the obvious analogue of (9.92).

Clearly

$$(9.96) \quad \left[Q, T f^\alpha \nabla_{f_\alpha^{H,W}}^\xi V \right] = T f^\alpha \tilde{\nabla}_{\rho(Z/2)U_i^H}^\xi \nabla_{f_\alpha^{H,W}}^\xi V.$$

By (9.20), near W ,

$$(9.97) \quad P^{\xi^-} f^\alpha \tilde{\nabla}_{\rho(Z/2)U_i^H}^\xi \nabla_{f_\alpha^{H,W}}^\xi V P^{\xi^-} = \mathcal{O}(|Z|^2).$$

From (9.97), we find that $\left[Q, T f^\alpha \nabla_{f_\alpha^{H,W}}^\xi V \right]$ also verifies the analogue of (9.94).

d) The case where $Q = \sqrt{T} \bar{p}_T^\perp f_j \bar{p}_T^\perp$.

Put

$$(9.98) \quad \begin{aligned} Q_1 &= \sqrt{T}(1 - \rho(Z/2)) \bar{p}_T^\perp f_j \bar{p}_T^\perp, \\ Q_2 &= \sqrt{T} \rho(Z/2) \bar{p}_T^\perp f_j \bar{p}_T^\perp. \end{aligned}$$

Clearly

$$(9.99) \quad Q = Q_1 + Q_2.$$

As we saw in part a) of our proof,

$$(9.100) \quad \bar{p}_T(1 - \rho(Z/2)) = (1 - \rho(Z/2))\bar{p}_T = 0.$$

Therefore

$$(9.101) \quad \begin{aligned} Q_1 &= \sqrt{T}(1 - \rho(Z/2)) f_j, \\ Q_2 &= \sqrt{T} \bar{p}_T^\perp \rho(Z/2) f_j \bar{p}_T^\perp. \end{aligned}$$

Clearly, $\left[(1 - \rho(Z/2)) f_j, \tilde{A}_T^2 \right]$ is a first order differential operator not depending on T , whose coefficients vanish when $\rho(Z) > 0$. Then we find easily that

$$(9.102) \quad \left| \left\langle \left[Q_1, \tilde{A}_T^2 \right] s, s' \right\rangle_0 \right| \leq C |s|_{T,1} |s'|_{T,1}.$$

By [19, Theorem 13.30],

$$(9.103) \quad \left| \left\langle \left[Q_2, \tilde{A}_T^{(0),2} \right] s, s' \right\rangle_0 \right| \leq C |s|_{T,1} |s'|_{T,1}.$$

We will show that

$$(9.104) \quad \left| \left\langle \left[Q_2, \tilde{R}_T \right] s, s' \right\rangle \right| \leq C |s|_{T,1} |s'|_{T,1}.$$

As before we take s, s' in E_T^1 or $E_T^{1,\perp}$, and s, s' not lying both in E_T^1 . Set $P = \rho(Z/2)f_j$. Then we write the obvious analogue of (9.91), i.e.

$$(9.105) \quad Q_2 = \sqrt{T}(P + \bar{p}_T P \bar{p}_T - \bar{p}_T P - P \bar{p}_T).$$

Since $[P, \tilde{R}_T]$ is an operator of order 0 which does not depend on T , $\sqrt{T}[P, \tilde{R}_T]$ is harmless in our estimates. Moreover near W ,

$$(9.106) \quad f_j \simeq \mathcal{O}(|Z|).$$

Using (9.66), (9.106), we find that if $s \in E_T^{1,\perp}$,

$$(9.107) \quad \left| \sqrt{T} \bar{p}_T P \bar{p}_T H s \right|_0 \leq C |s|_{T,1}.$$

From (9.107), we deduce that $[\sqrt{T} \bar{p}_T P \bar{p}_T, H]$ is also harmless. The same argument shows that the other commutators of the remaining terms in the expression (9.105) for Q_2 with H are harmless.

Finally

$$(9.108) \quad [P, T f^\alpha \nabla_{f_\alpha^{H,W}}^\xi V] = 0.$$

Using (9.93) and (9.108), we control the commutators $[Q_2, T f^\alpha \nabla_{f_\alpha^{H,W}}^\xi V]$.

This completes the case of commutators of length 1.

e) Higher order commutators.

As we saw in a), if $1 - \rho(Z/2) > 0$, then $\rho(Z) = 0$. Therefore in the commutators containing one of the $\nabla_{(1-\rho(Z/2))U_i}^{\Lambda(T^{*(0,1)}X) \otimes \xi}$, we can replace everywhere \bar{p}_T^\perp by 1. The corresponding estimates are then trivial in this case.

For commutators not containing the $\nabla_{(1-\rho(Z/2))U_i}^{\Lambda(T^{*(0,1)}X) \otimes \xi}$'s, the contribution of $\tilde{A}_T^{(0),2}$ to the corresponding estimates was already obtained in [19, Theorem 13.30]. More generally, by using formulas of the type (9.91) repeatedly, one verifies that the estimates needed to prove (9.87) for $k > 1$ are exactly of the same nature as before.

The proof of Theorem 9.17 is completed. □

If $A \in \mathcal{L}(E^m, E^{m'})$, we denote by $\| \| A \| \|_T^{m,m'}$ the norm of A with respect to the norms $\| \|_{T,m}, \| \|_{T,m'}$.

Theorem 9.18 — *For any $m \in \mathbb{N}$, there exist $p_m \in \mathbb{N}$, $C_m > 0$ such that for $T \geq T_0$, $\lambda \in \Delta$,*

$$(9.109) \quad \left\| \left\| (\lambda - \tilde{A}_T^2)^{-1} \right\| \right\|_T^{m,m+1} \leq C_m (1 + |\lambda|)^{p_m}.$$

Proof. Clearly for $T \geq 1$

$$(9.110) \quad \|s\|_{T,1} \leq C |s|_{T,1} .$$

□

When $m = 0$, our Theorem follows from Theorem 9.15 and from (9.110).

Using Theorems 9.15 and 9.17 instead of [19, Theorem 11.27 and Proposition 11.29], the proof of our Theorem proceed as the proof of [19, Theorem 11.30].

□

If $a \notin \Delta$, put

$$(9.111) \quad F_u(a) = \frac{1}{2\pi i} \int_{\Delta} \frac{\exp(-u^2\lambda)}{\lambda - a} d\lambda .$$

Then

$$(9.112) \quad \begin{aligned} F_u(a) &= \exp(-u^2a) && \text{if } a \text{ lies inside the contour } \Delta, \\ &= 0 && \text{if } a \text{ lies outside } \Delta. \end{aligned}$$

Put

$$(9.113) \quad F_u(\tilde{A}_T^2) = \frac{1}{2\pi i} \int_{\Delta} \frac{\exp(-u^2\lambda)}{\lambda - \tilde{A}_T^2} d\lambda .$$

Definition 9.19. Let $F_u(\tilde{A}_T^2)(x, x')$ ($x, x' \in X$) be the smooth kernel associated to the operator $F_u(\tilde{A}_T^2)$ with respect to $\frac{dv_X(x')}{(2\pi)^{\dim X}}$.

9.9 Uniform estimates on the kernel $F_u(\tilde{A}_T^2)$

Theorem 9.20 — For any $\alpha > 0$, $m \in \mathbb{N}$, there exist $C > 0$, $C' > 0$ such that if $x \in V$, $d^X(x, Y) \geq \alpha$, for $u \geq u_0$, $T \geq T_0$,

$$(9.114) \quad F_u(\tilde{A}_T^2)(x, x') \leq \frac{C \exp(-C'u^2)}{T^m} .$$

For any $m \in \mathbb{N}$, there exist $C > 0$, $C' > 0$ such that for $y \in W$, $u \geq u_0$, $T \geq T_0$,

$$(9.115) \quad \sup_{|Z| \leq \frac{\alpha}{2}\sqrt{T}} (1 + |Z|)^m \frac{1}{T^{\dim N_{Y/X}}} \left| F_u(\tilde{A}_T^2) \left(\left(y, \frac{Z}{\sqrt{T}} \right), \left(y, \frac{Z}{\sqrt{T}} \right) \right) \right| \leq C \exp(-C'u^2) .$$

For any $m \in \mathbf{N}$, there exist $C > 0$, $C' > 0$, such that for $y \in W$, $u \geq u_0$, $T \geq T_0$,

$$(9.116) \quad \sup_{\substack{|\alpha| \leq m', |\alpha'| \leq m' \\ |Z| \leq \frac{\epsilon}{2} \sqrt{T} \\ |Z'| \leq \frac{\epsilon}{2} \sqrt{T}}} \sup \left| \frac{\partial^{|\alpha|+|\alpha'|}}{\partial x^\alpha \partial x'^{\alpha'}} \frac{1}{T^{\dim N_{Y/X}}} \right| F_u(\tilde{A}_T^2) \left(\left(y, \frac{Z}{\sqrt{T}} \right), \left(y', \frac{Z'}{\sqrt{T}} \right) \right) \leq C \exp(-C' u^2).$$

Proof. Clearly for any $p \in \mathbf{N}$,

$$(9.117) \quad \frac{1}{2\pi i} \int_{\Delta} \frac{\exp(-u^2 \lambda)}{\lambda - \tilde{A}_T^2} d\lambda = (-1)^{2p-1} \frac{(2p-1)!}{2\pi i (u^2)^{2p-1}} \int_{\Delta} \frac{\exp(-u^2 \lambda)}{(\lambda - \tilde{A}_T^2)^{2p}} d\lambda.$$

□

By Theorem 9.18, we know that there exists $C > 0$, $q \in \mathbf{N}$ such that if $\lambda \in \Delta$, $Q \in \mathcal{Q}_T^\ell$, $\ell \leq p$,

$$(9.118) \quad \left\| Q(\lambda - \tilde{A}_T^2)^{-p} \right\|_T^{0,0} \leq C(1 + |\lambda|)^q.$$

By introducing the obvious adjoint operator with respect to the Hermitian product $\langle \cdot, \cdot \rangle_0$, we also find that if $\lambda \in \Delta$, $Q' \in \mathcal{Q}_T^\ell$, $\ell \leq p$,

$$(9.119) \quad \left\| (\lambda - \tilde{A}_T^2)^{-p} Q' \right\|_T^{0,0} \leq C(1 + |\lambda|)^q.$$

From (9.118), (9.119), we see that if $\lambda \in \Delta$, $Q \in \mathcal{Q}_T^\ell$, $Q' \in \mathcal{Q}_T^{\ell'}$, $\ell, \ell' \leq p$,

$$(9.120) \quad \left\| Q(\lambda - \tilde{A}_T^2)^{-2p} Q' \right\|_T^{0,0} \leq C(1 + |\lambda|)^{2q}.$$

From (9.117), (9.120), we find that if $Q \in \mathcal{Q}_T^\ell$, $Q' \in \mathcal{Q}_T^{\ell'}$, there exist $C > 0$, $C' > 0$ such that

$$(9.121) \quad \left\| Q F_u(\tilde{A}_T^2) Q' \right\|_T^{0,0} \leq C \exp(-C' u^2).$$

By (9.121) and by Sobolev inequalities, we get (9.114). Using (9.120) and proceeding as in [19, proof of Theorem 13.32], we obtain (9.115), (9.116).

The proof of our Theorem is completed. □

Now we establish an analogue of [19, Proposition 13.33].

Proposition 9.21 — *There exist $C > 0$, $p \in \mathbf{N}$ such that for $T \geq T_0$, $\lambda \in \Delta \cup \delta$, then*

$$(9.122) \quad \left\| \bar{p}_T^\perp (\lambda - \tilde{A}_T^2)^{-1} \right\|^{0,0} \leq \frac{C}{\sqrt{T}} (1 + |\lambda|)^p.$$

Proof. This follows immediately from Theorem 9.15. \square

At this stage, we are in a situation formally very similar to the one described in [19, Section 13 o)]. Note that here, contrary to what was done in [19], the Hermitian product $\langle \cdot, \cdot \rangle_0$ does not vary with T . In particular, none of the subtleties involved in the proof of [19, Proposition 13.34] does appear.

If A is a bounded operator acting on E , we write A in matrix form with respect to the splitting $E^0: E_T^0 \oplus E_T^{0,\perp}$

$$A = \begin{bmatrix} A_1 & A_2 \\ A_3 & A_4 \end{bmatrix}$$

so that $A_1 = \bar{p}_T A \bar{p}_T, \dots$

Now we give an analogue of [19, Proposition 13.35].

Proposition 9.22 — *There exist $C > 0$, $p \in \mathbf{N}$, $T_0 \geq 1$ such that if $T \geq T_0$, $\lambda \in \Delta$, the resolvent $(\lambda - \tilde{A}_{T,4}^2)^{-1}$ exists and moreover*

$$(9.123) \quad \left\| (\lambda - \tilde{A}_{T,4}^2)^{-1} \right\|_T^{-1,1} \leq C(1 + |\lambda|)^p.$$

Proof. By Theorem 9.14, it is clear that $\tilde{A}_{T,4}^2$ verifies inequalities similar to (9.44). Therefore by using the notation in (9.74), for $\delta > 0$ small enough, and $A > 0$ large enough, if $\lambda \in U$, then

$$(9.124) \quad \begin{aligned} \left\| (\lambda - \tilde{A}_{T,4}^2)^{-1} \right\|^{0,0} &\leq C, \\ \left\| (\lambda - \tilde{A}_{T,4}^2)^{-1} \right\|_T^{-1,1} &\leq C(1 + |\lambda|)^2. \end{aligned}$$

\square

By Theorem 9.14, for $T \geq 1$ large enough, if $s \in E_T^{1,\perp}$,

$$(9.125) \quad \left\langle \tilde{A}_T^{(0),2} s, s \right\rangle_0 \geq CT |\bar{p}_T^\perp s|_0^2.$$

By (9.125), we find that there is $C > 0$, $T_0 \geq 1$ such that for $T \geq T_0$, $\lambda \in \Delta \cup \delta$,

$$(9.126) \quad \left\| (\lambda - \tilde{A}_{T,4}^{(0),2})^{-1} \right\|^{0,0} \leq C.$$

Using (9.124), (9.126), and proceeding as in (9.75)-(9.80), we get for $T \geq T_0$, $\lambda \in \Delta \cup \delta$,

$$(9.127) \quad \left\| (\lambda - \tilde{A}_{T,4}^{(0),2})^{-1} \right\|_T^{-1,1} \leq C(1 + |\lambda|)^2.$$

Then if $\lambda \in \Delta \cup \delta$,

$$(9.128) \quad (\lambda - \tilde{A}_{T,4}^2)^{-1} = (\lambda - A_{T,4}^{(0),2})^{-1} + (\lambda - \tilde{A}_{T,4}^{(0),2})^{-1} \tilde{R}_{T,4} (\lambda - \tilde{A}_{T,4}^{(0),2})^{-1} + \dots$$

By Theorem 9.14, we get

$$(9.129) \quad \left\| \tilde{R}_{T,4} \right\|_T^{1,-1} \leq C.$$

By (9.128)-(9.129) and by proceeding as in (9.81)-(9.82), we obtain (9.123). \square

Now we give an analogue of [19, Theorem 13.39].

Theorem 9.23 — *There exist $C > 0$, $C' > 0$ such that for $u \geq 1$, $T \geq T_0$,*

$$(9.130) \quad \begin{aligned} \left\| \bar{p}_T^\perp F_u(\tilde{A}_T^2) \bar{p}_T^\perp \right\|^{0,0} &\leq \frac{C}{\sqrt{T}}, \\ \left\| \bar{p}_T^\perp F_u(\tilde{A}_T^2) \bar{p}_T \right\|^{0,0} &\leq \frac{C}{\sqrt{T}}, \\ \left\| \bar{p}_T F_u(\tilde{A}_T^2) \bar{p}_T^\perp \right\|^{0,0} &\leq \frac{C}{\sqrt{T}}. \end{aligned}$$

Proof. In view of Proposition 9.21, we can proceed exactly as in [19, p. 264-267]. Note that contrary to [19, Section 13 o)], we do not need to introduce the operator \tilde{p} of [19, Section 13] (at least for the moment!) and this simplifies the discussion considerably. \square

9.10 The matrix structure of \tilde{A}_T^2 as $T \rightarrow +\infty$

Recall that the operator $D^{N_{Y/X}}$ acting on \mathbf{E} was defined in Definition 8.2. Let $D^{N_{Y/X,-}}$ be the restriction of $D^{N_{Y/X}}$ to \mathbf{E}^- . Similarly let V^\pm be the restriction of V to ξ^\pm .

Now we will use the notation of Chapter 8. Let $\mathbf{E}'^{0,\perp,-}$ be the orthogonal bundle to \mathbf{E}'^0 in $\mathbf{E}^{0,-}$. The bundle \mathbf{E}^0 splits orthogonally as

$$(9.131) \quad \mathbf{E}^0 = \mathbf{E}'^0 \oplus \mathbf{E}'^{0,\perp,-} \oplus \mathbf{E}^{+0}.$$

We write $F_T k^{1/2} \tilde{A}_T^2 k^{-1/2} F_T^{-1}$ as a (3,3) matrix with respect to the splitting (9.131),

$$(9.132) \quad \begin{bmatrix} A_T & B_T & C_T \\ D_T & E_T & F_T \\ G_T & H_T & I_T \end{bmatrix}.$$

By squaring (8.10), we obtain the asymptotic expansion of (9.132). Since $\mathbf{E}'^{0,\perp,-} \oplus \mathbf{E}'^0 = \ker V^+|_W$, and since by Section 8.3, $\mathbf{E}'^0 = \ker (D^{N_{Y/X,-}} + \sqrt{-1} \frac{\partial(Z)}{\sqrt{2}}) \subset \mathbf{E}^{0,-}$, we deduce from (8.10) that

$$(9.133) \quad \begin{aligned} A_T &= A + \mathcal{O}\left(\frac{1}{\sqrt{T}}\right), & B_T &= \sqrt{T}B + \mathcal{O}(1), & C_T &= TC + \mathcal{O}(\sqrt{T}), \\ D_T &= \sqrt{T}D + \mathcal{O}(1), & E_T &= TE + \mathcal{O}(1), & F_T &= TF + \mathcal{O}(1), \\ G_T &= TG + \mathcal{O}(\sqrt{T}), & H_T &= TH + \mathcal{O}(\sqrt{T}), & I_T &= T^2I + \mathcal{O}(T^{3/2}). \end{aligned}$$

From (8.10), we get the analogue of [19, eq. (13.356)],

$$\begin{aligned}
 A &= p\mathfrak{B}^2p, \\
 B &= p \left[D^{N_Y/x,-} + \sqrt{-1} \frac{\widehat{c}(Z)}{\sqrt{2}}, \mathfrak{B} \right] p^\perp, \\
 C &= p \left[V_{|W}^+, \mathfrak{B} \right] P^{\xi^+}, \\
 (9.134) \quad D &= p^\perp P^{\xi^-} \left[D^{N_Y/x,-} + \sqrt{-1} \frac{\widehat{c}(Z)}{\sqrt{2}}, \mathfrak{B} \right] p, \\
 E &= p^\perp P^{\xi^-} \left(D^{N_Y/x,-} + \sqrt{-1} \frac{\widehat{c}(Z)}{\sqrt{2}} \right)^2 P^{\xi^-} p^\perp, \\
 G &= P^{\xi^+} \left[V_{|W}^+, \mathfrak{B} \right] p, \\
 I &= V_{|W}^{+,2}.
 \end{aligned}$$

Definition 9.24. Let Ξ be the second order differential operator acting on F

$$(9.135) \quad \Xi = \psi^{-1}(A - BE^{-1}D - CI^{-1}G)\psi.$$

Now we extend [19, Theorem 13.43].

Theorem 9.25 — *The following identity holds,*

$$(9.136) \quad B_1^{W,2} = \Xi.$$

Proof. By (9.134), (9.135), we find that

$$(9.137) \quad \Xi = \psi^{-1} \left(p\mathfrak{B}^2p - p\mathfrak{B}p^\perp P^{\xi^-} \mathfrak{B}p - p\mathfrak{B}P^{\xi^+} \mathfrak{B}p \right) \psi,$$

and so

$$(9.138) \quad \Xi = \psi^{-1}(p\mathfrak{B}p)^2\psi.$$

Now we use Theorem 8.8 and (9.138), and we get (9.136). The proof of our Theorem is completed. □

We give an analogue of [19, Theorem 13.41].

Theorem 9.26 — *There exist $p \in \mathbf{N}$, $C > 0$ such that for $\lambda \in \Delta$, $T \geq T_0$,*

$$(9.139) \quad \left\| \widetilde{A}_{T,1}^2 + \widetilde{A}_{T,2}^2 \left(\lambda - \widetilde{A}_{T,4}^2 \right)^{-1} \widetilde{A}_{T,3}^2 - \bar{p}_T J_T \Xi J_T^{-1} \bar{p}_T \right\|_T^{1,-1} \leq \frac{C}{T^{1/4}}.$$

Proof. In view of (9.133), the proof of (9.139) is the same as the proof of [19, Theorem 13.41]. □

Set

$$(9.140) \quad F_u(B_1^{W,2}) = \frac{1}{2i\pi} \int_{\Delta} \frac{\exp(-u^2\lambda)}{\lambda - B_1^{W,2}} d\lambda.$$

Let $F_u(B_1^{W,2})(y, y')$ ($y, y' \in Y$) be the smooth kernel of $F_u(B_1^{W,2})$ with respect to $\frac{dv_Y(y')}{(2\pi)^{\dim Y}}$.

9.11 The asymptotics of the operator $F_u(\tilde{A}_T^2)$ as $T \rightarrow +\infty$

The analogue of [19, Theorem 13.42] is now.

Theorem 9.27 — *There exist $c > 0$, $C > 0$ such that for $u \geq u_0$, $T \geq 1$,*

$$(9.141) \quad \left\| F_u(\tilde{A}_T^2) - \bar{p}_T J_T F_u(B_1^{W,2}) J_T^{-1} \bar{p}_T \right\|^{0,0} \leq \frac{c \exp(-Cu^2)}{T^{1/4}}.$$

Proof. In view of Theorem 9.26, the proof of (9.141) is the same as the proof of [19, Theorem 13.42]. \square

9.12 Proof of Theorem 9.5

Clearly

$$(9.142) \quad \text{Tr}_s \left[(\tilde{N}_1^V - N_{\mathbf{H}}) \frac{1}{2\pi i} \int_{\Delta} \frac{\exp(-u^2\lambda)}{\lambda - \tilde{A}_T^2} d\lambda \right] = \int_X \text{Tr}_s \left[(\tilde{N}_1^V - N_{\mathbf{H}}) F_u(\tilde{A}_T^2)(x, x) \right] \frac{dv_X(x)}{(2\pi)^{\dim X}}.$$

By Theorem 9.20, for any $m \in \mathbf{N}$

$$(9.143) \quad \left| \int_{X \cap \{x, d^X(x, Y) \geq \varepsilon/4\}} \text{Tr}_s \left[(\tilde{N}_1^V - N_{\mathbf{H}}) F_u(\tilde{A}_T^2)(x, x) \right] \frac{dv_X(x)}{(2\pi)^{\dim X}} \right| \leq \frac{C}{T^m} \exp(-C'u^2).$$

Also

$$(9.144) \quad \int_{X \cap \{x, d^X(x, Y) \leq \varepsilon/4\}} \text{Tr}_s \left[(\tilde{N}_1^V - N_{\mathbf{H}}) F_u(\tilde{A}_T^2)(x, x) \right] \frac{dv_X(x)}{(2\pi)^{\dim X}} = \int_Y \frac{dv_Y(y)}{(2\pi)^{\dim Y}} \int_{Z \in N_{Y/X}, |Z| \leq \frac{\varepsilon}{4} \sqrt{T}} \text{Tr}_s \left[(\tilde{N}_1^V - N_{\mathbf{H}}) \frac{F_u(\tilde{A}_T^2)}{T^{\dim N_{Y/X}}} \left(\left(y, \frac{Z}{\sqrt{T}} \right), \left(y, \frac{Z}{\sqrt{T}} \right) \right) \right] k \left(y, \frac{Z}{\sqrt{T}} \right) \frac{dv_{N_{Y/X}}(Z)}{(2\pi)^{\dim N_{Y/X}}}.$$

□

Using Theorems 9.20 and 9.27 and proceeding as in [19, Section 13 q)], we find that there exist $c > 0$, $C > 0$, $\delta \in]0, 1/2]$ such that if $y \in W$, $Z \in N_{Y/X, \mathbf{R}, y}$, $|Z| \leq \frac{\varepsilon\sqrt{T}}{4}$,

$$(9.145) \quad \left| \left(\frac{1}{2\pi} \right)^{\dim X} \frac{1}{T^{\dim N_{Y/X}}} F_u(\tilde{A}_T^2) \left(\left(y, \frac{Z}{\sqrt{T}} \right), \left(y, \frac{Z}{\sqrt{T}} \right) \right) k \left(y, \frac{Z}{\sqrt{T}} \right) \right. \\ \left. - \frac{\rho^2 \left(\frac{Z}{\sqrt{T}} \right)}{\alpha_T T^{\dim N_{Y/X}}} \frac{\exp(-|Z|^2)}{(2\pi)^{\dim N_{Y/X}}} \left(\frac{1}{2\pi} \right)^{\dim Y} F_u(B_1^{W,2})(y, y) q \right| \leq \frac{c \exp(-Cu^2)}{T^\delta}.$$

By (9.115), (9.145), we find that for any $p \in \mathbf{N}$, there is $c > 0$, $C > 0$ such that if $y \in W$, $Z \in N_{Y/X, \mathbf{R}, y}$, $|Z| \leq \frac{\varepsilon\sqrt{T}}{4}$,

$$(9.146) \quad \left| \left(\frac{1}{2\pi} \right)^{\dim X} \frac{1}{T^{\dim N_{Y/X}}} F_u(\tilde{A}_T^2) \left(\left(y, \frac{Z}{\sqrt{T}} \right), \left(y, \frac{Z}{\sqrt{T}} \right) \right) k \left(y, \frac{Z}{\sqrt{T}} \right) \right. \\ \left. - \frac{\rho^2 \left(\frac{Z}{\sqrt{T}} \right)}{\alpha_T T^{\dim N_{Y/X}}} \frac{\exp(-|Z|^2)}{(2\pi)^{\dim N_{Y/X}}} \left(\frac{1}{2\pi} \right)^{\dim Y} F_u(B_1^{W,2})(y, y) q \right| \leq \frac{c \exp(-Cu^2)}{(1 + |Z|)^p T^{\delta/2}}.$$

Finally there is $C' > 0$ such that

$$(9.147) \quad \alpha_T = \frac{1}{(2T)^{\dim N_{Y/X}}} + \mathcal{O}(e^{-C'T}).$$

From (9.146), (9.147), we deduce that there exist $c > 0$, $C > 0$, $\delta \in]0, 1/4]$ such that

$$(9.148) \quad \left| \int_Y \frac{dv_Y(y)}{(2\pi)^{\dim Y}} \int_{|Z| \leq \frac{\varepsilon\sqrt{T}}{4}} \right. \\ \left. \text{Tr}_s \left[(\tilde{N}_1^V - N_{\mathbf{H}}) F_u(\tilde{A}_T^2) \left(\left(y, \frac{Z}{\sqrt{T}} \right), \left(y, \frac{Z}{\sqrt{T}} \right) \right) \right] k \left(y, \frac{Z}{\sqrt{T}} \right) \frac{dv_{N_{Y/X}}(Z)}{(2\pi)^{\dim N_{Y/X}}} \right. \\ \left. - \text{Tr}_s \left[q(\tilde{N}_1^V - N_{\mathbf{H}}) q F_u(B_1^{W,2}) \right] \right| \leq \frac{c \exp(-Cu^2)}{T^\delta}.$$

So by Theorem 8.8 and by (9.142)-(9.144), (9.148), we obtain

$$(9.149) \quad \left| \text{Tr}_s \left[(\tilde{N}_1^V - N_{\mathbf{H}}) F_u(\tilde{A}_T^2) \right] - \text{Tr}_s \left[N_1^W F_u(B_1^{W,2}) \right] \right| \leq \frac{c \exp(-Cu^2)}{T^\delta}.$$

Also by (9.111), we get for $u \geq u_0$,

$$(9.150) \quad \left| \text{Tr}_s \left[N_1^W F_u(B_1^{W,2}) \right] \right| \leq c \exp(-Cu^2).$$

Using (9.149), (9.150), we get the first inequality in (9.14) and the “difference” of the inequalities (9.15). Also, by using Theorem 8.8 again, we get the second inequality in (9.14) and also the full (9.15).

The proof of Theorem 9.5 is completed. □

9.13 The operators $\mathcal{G}_{a,b,c,T}$

Definition 9.28. For $a \in \mathbf{C}^*$, $b \in \mathbf{C}$, $c \in \mathbf{C}$, $T \geq 1$, set

$$(9.151) \quad \mathcal{G}_{a,b,c,T} = \frac{A_T^{(0),2}}{a^2} + \left(\nabla^E - \frac{bc(T^V)}{2\sqrt{2}} \right)^2 + \left[c\nabla^E - \frac{c(T^V)}{2\sqrt{2}}, A_T^{(0)} \right],$$

$$R_{b,c,T} = \left(\nabla^E - \frac{bc(T^V)}{2\sqrt{2}} \right)^2 + \left[c\nabla^E - \frac{c(T^V)}{2\sqrt{2}}, A_T^{(0)} \right].$$

For $T \geq 1$, recall that $\tilde{K}_T = \ker A_T^{(0)}$ and that \tilde{P}_T is the orthogonal projection operator $E \rightarrow \tilde{K}_T$ with respect to $\langle \cdot, \cdot \rangle = \langle \cdot, \cdot \rangle_1$. Let $\left[A_T^{(0),2} \right]^{-1}$ be the operator in $\text{End}(E)$ which vanishes on \tilde{K}_T , and coincides with the inverse of $A_T^{(0),2}$ on \tilde{K}_T^\perp .

Theorem 9.29 — For $a \in \mathbf{C}^*$, $|a| < 1$, $b \in \mathbf{C}$, $c \in \mathbf{C}$, $T \geq T_0$, then

$$(9.152) \quad \frac{1}{2\pi i} \int_\delta \frac{\exp(-\lambda)}{\lambda - \mathcal{G}_{a,b,c,T}} d\lambda = \sum_{p=0}^{2 \dim S} \sum_{\substack{1 \leq i_0 \leq p+1 \\ 0 \leq j_1, \dots, j_{p+1-i_0} \\ j_1 + \dots + j_{p+1-i_0} \leq i_0 - 1}} \frac{(-1)^{p-j_1 \dots - j_{p+1-i_0}}}{(i_0 - 1 - j_1 \dots - j_{p+1-i_0})!} C_1 R_{b,c,T} C_2 R_{b,c,T} \dots R_{b,c,T} C_{p+1},$$

where in the right-hand side of (9.152), i_0 of the C_j 's are equal to \tilde{P}_T , and the other C_j 's are respectively given by $\left(a^2 \left[A_T^{(0),2} \right]^{-1} \right)^{1+j_1}, \dots, \left(a^2 \left[A_T^{(0),2} \right]^{-1} \right)^{1+j_{p+1-i_0}}$. In particular each term in the right-hand side of (9.152) is a monomial in a and a polynomial in b, c .

Moreover if C_1, \dots, C_{p+1} are chosen as indicated before,

$$(9.153) \quad \begin{aligned} \deg_c(C_1 R_{b,c,T} C_2 R_{b,c,T} \dots R_{b,c,T} C_{p+1}) &\leq 2(p+1-i_0), \\ \deg_a(C_1 R_{b,c,T} C_2 R_{b,c,T} \dots R_{b,c,T} C_{p+1}) &= 2(p+1-i_0 + j_1 + \dots + j_{p+1-i_0}). \end{aligned}$$

The inequality in the first line of (9.153) is an equality if and only if $\left[c\nabla^E, A_T^{(0)} \right]$ appears exactly $2(p+1-i_0)$ times in sequences of the form

$$(9.154) \quad \tilde{P}_T \left[c\nabla^E, A_T^{(0)} \right] \left(a^2 \left[A_T^{(0),2} \right]^{-1} \right)^{1+j_k} \left[c\nabla^E, A_T^{(0)} \right] \tilde{P}_T,$$

the other C_i 's being equal to \tilde{P}_T .

Proof. Clearly $R_{b,c,T}$ lies in $\Lambda(T_{\mathbf{R}}^*S) \widehat{\otimes} \text{End}(E)$ and its partial degree in $\Lambda(T_{\mathbf{R}}^*S)$ is positive. Using Theorem 9.1, we find that

$$(9.155) \quad \frac{1}{\lambda - \mathcal{G}_{a,b,c,T}} = \frac{1}{\lambda - \frac{A_T^{(0),2}}{a^2}} + \frac{1}{\lambda - \frac{A_T^{(0),2}}{a^2}} R_{b,c,T} \frac{1}{\lambda - \frac{A_T^{(0),2}}{a^2}} + \dots$$

and the sum in (9.155) is a finite sum with at most $2 \dim S + 1$ terms.

Also

$$(9.156) \quad \exp(-\lambda) = \sum_{k \geq 0} (-1)^k \frac{\lambda^k}{k!}.$$

By Theorem 9.1, for $T \geq T_0$, $|a| < 1$, 0 is the only eigenvalue of $A_T^{(0),2}/a^2$ lying inside δ . Using (9.155), (9.156) and the residue theorem, we get (9.152). Clearly each term in the right-hand side of (9.152) is a polynomial in a, b, c .

If s is a smooth section of \widetilde{K}_T , then

$$(9.157) \quad A_T^{(0)} s = 0$$

and so

$$(9.158) \quad [\nabla^E, A_T^{(0)}] s - A_T^{(0)} \nabla^E s = 0.$$

From (9.158), we deduce that

$$(9.159) \quad \widetilde{P}_T [\nabla^E, A_T^{(0)}] \widetilde{P}_T = 0.$$

Therefore in the right-hand side of (9.152), expressions of the form $\widetilde{P}_T [c \nabla^E, A_T^{(0)}] \widetilde{P}_T$ never appear. Now we list the other sequences of terms where $[c \nabla^E, A_T^{(0)}]$ can appear, and their partial degree in a and c . Clearly

$$(9.160) \quad \begin{aligned} \deg_a \left(a^2 [A_T^{(0),2}]^{-1} \right)^{1+jk} R_{b,c,T} &\geq 2, \\ \deg_c \left(a^2 [A_T^{(0),2}]^{-1} \right)^{1+jk} R_{b,c,T} &= 1, \\ \deg_a \widetilde{P}_T R_{b,c,T} \left(a^2 [A_T^{(0),2}]^{-1} \right)^{1+jk} R_{b,c,T} &\geq 2, \\ \deg_c \widetilde{P}_T R_{b,c,T} \left(a^2 [A_T^{(0),2}]^{-1} \right)^{1+jk} R_{b,c,T} &= 2, \\ \deg_a \widetilde{P}_T R_{b,c,T} \left(a^2 [A_T^{(0),2}]^{-1} \right)^{1+jk} &\geq 2, \\ \deg_c \widetilde{P}_T R_{b,c,T} \left(a^2 [A_T^{(0),2}]^{-1} \right)^{1+jk} &= 1. \end{aligned}$$

In the right-hand side of (9.160), the even rows are dominated by the odd rows. Therefore we deduce that the degree in c of $C_1 R_{b,c,T} C_2 \dots R_{b,c,T} C_p$ is dominated by $2(p + 1 - i_0)$, i.e. we obtain the first inequality in (9.153). The second equality in (9.153) is trivial.

The case where there is equality in (9.153) corresponds to the case where the even and odd right-hand sides of (9.160) are equal, and only terms of the highest degree in c appear. This excludes the first and third sort of terms in (9.160).

Our Theorem follows. □

From Theorem 9.29, we deduce that if N is one of the operators $N_V^X, N_H, \omega^{V,H}$ then

$$(9.161) \quad \text{Tr}_s \left[N \frac{1}{2\pi i} \int_\delta \frac{\exp(-\lambda)}{\lambda - \mathcal{G}_{a,b,c,T}} d\lambda \right] = \sum_{\substack{0 \leq n \leq \ell \leq 4 \dim S \\ 0 \leq m \leq 4 \dim S}} O_{\ell,m,n}(T) a^\ell b^m c^n,$$

where the $O_{\ell,m,n}(T)$ lie in P^S .

Theorem 9.30 — *If N is taken as in (9.161), there exist forms $O_{\ell,m,n}(\infty) \in P^S$ and $C > 0, \delta \in]0, 1/2]$ such that for $T \geq T_0, 0 \leq n \leq \ell \leq 4 \dim S, 0 \leq m \leq 4 \dim S,$*

$$(9.162) \quad |O_{\ell,m,n}(T) - O_{\ell,m,n}(\infty)| \leq \frac{C}{T^\delta}.$$

Proof. We will show that there is a smooth form on $S, h(a, b, c),$ depending holomorphically on $\{a \in \mathbf{C}, b \in \mathbf{C}, c \in \mathbf{C}, \frac{1}{4} \leq |a| \leq 1/2, |b| \leq 1/2, |c| \leq 1/2\},$ $C > 0,$ and $\delta \in]0, \frac{1}{2}]$ such that for $T \geq T_0,$

$$(9.163) \quad \left| \text{Tr}_s \left[N \frac{1}{2\pi i} \int_\delta \frac{\exp(-\lambda)}{\lambda - \mathcal{G}_{a,b,c,T}} d\lambda \right] - h(a, b, c) \right| \leq \frac{C}{T^\delta}.$$

Using (9.161), (9.163) and Cauchy's residue formula, we get (9.162).

In view of (3.15), (9.151), we see that $\mathcal{G}_{a,b,c,T}$ is obtained from A_T^2 by scaling

- the piece of degree 0 by $\frac{1}{a^2}$;
- the piece of degree 1 by c ;
- the piece of degree 2 is unscaled;
- the piece of degree 3 by b ;
- the piece of degree 4 by b^2 .

Put

$$(9.164) \quad \tilde{\mathcal{G}}_{a,b,c,T} = \exp \left\{ -a^2 c f^\alpha \frac{c(f_\alpha^{H, N_{Y/X}})}{\sqrt{2}} \right\} \mathcal{G}_{a,b,c,T} \exp \left\{ a^2 c f^\alpha \frac{c(f_\alpha^{H, N_{Y/X}})}{\sqrt{2}} \right\}.$$

As in (7.49), the essential effect of this transformation is to replace in the expression (9.151) for $\mathcal{G}_{a,b,c,T}$ the term $[c \nabla^E, TV] = cT f^\alpha \nabla_{f_\alpha^{H,V}}^\xi V$ by $cT f^\alpha \nabla_{f_\alpha^{H,W}}^\xi V$.

The proof of (9.163) proceeds otherwise exactly as in Sections 9.6-9.11. The fact that $\frac{1}{2} \leq |a| \leq 1$ makes that all the considered quantities are well-defined. Then the discussion of the previous Subsections can be exactly reproduced. In particular, because of Theorem 9.1 and Proposition 9.2, in Theorem 9.15, we can replace $\lambda \in \Delta$ by $\lambda \in \delta$.

The previous scaling considerations show easily that as $T \rightarrow +\infty$, $F_T k^{1/2} \tilde{\mathcal{G}}_{a,b,c,T} k^{-1/2} F_T^{-1}$ has a matrix structure similar to (9.132)-(9.134).

By the procedure indicated in Definition 9.24, we produce a second order elliptic operator $\Xi_{a,b,c}$ acting on F such that the obvious analogue of Theorem 9.26 holds. Of course this operator does not has as simple an expression as the expression given for Ξ in Theorem 9.25.

From these arguments, we obtain easily (9.163). The proof of our Theorem is completed. \square

9.14 Proof of Theorem 9.6

Clearly

$$(9.165) \quad B_{u,T}^2 = \mathcal{G}_{\frac{1}{u}, \frac{1}{u}, u, T}.$$

From (9.161), we see that if N is one of the operators $N_{\mathbf{V}}^X, N_{\mathbf{H}}, \omega^{V,H}$, then

$$(9.166) \quad \text{Tr}_s \left[N \frac{1}{2\pi i} \int_{\delta} \frac{\exp(-\lambda)}{\lambda - B_{u,T}^2} d\lambda \right] = \sum_{\substack{0 \leq n \leq \ell \leq 4 \dim S \\ 0 \leq m \leq 4 \dim S}} O_{\ell,m,n}(T) u^{-\ell-m+n}.$$

Clearly if $u \geq u_0$, for $0 \leq n \leq \ell, 0 \leq m$,

$$(9.167) \quad u^{-\ell-m+n} \leq C.$$

Using Theorem 9.30 and (9.166), (9.167), we find that for $u \geq u_0, T \geq 1$,

$$(9.168) \quad \left| \text{Tr}_s \left[N \frac{1}{2\pi i} \int_{\delta} \frac{\exp(-\lambda)}{\lambda - B_{u,T}^2} d\lambda \right] - \sum_{\substack{0 \leq n \leq \ell \leq 4 \dim S \\ 0 \leq m \leq 4 \dim S}} O_{\ell,m,n}(\infty) u^{-\ell-m+n} \right| \leq \frac{C}{T^{\delta}}.$$

For a given $u > 0$, we can calculate the limit as $T \rightarrow +\infty$ of $\text{Tr}_s \left[N \frac{1}{2\pi i} \int_{\delta} \frac{\exp(-\lambda)}{\lambda - B_{u,T}^2} d\lambda \right]$ by the recipe already indicated in Section 9.12. We get

$$(9.169) \quad \lim_{T \rightarrow +\infty} \text{Tr}_s \left[N \frac{1}{2\pi i} \int_{\delta} \frac{\exp(-\lambda)}{\lambda - B_{u,T}^2} d\lambda \right] = \text{Tr}_s \left[qNq \frac{1}{2\pi i} \int_{\delta} \frac{\exp(-\lambda)}{\lambda - B_{u^2}^{W,2}} d\lambda \right].$$

From (9.168), (9.169), we see that

$$(9.170) \quad \sum_{\substack{0 \leq n \leq \ell \leq 4 \dim S \\ 0 \leq m \leq 4 \dim S}} O_{\ell, m, n}(\infty) u^{-\ell-m+n} = \text{Tr}_s \left[q N q \frac{1}{2\pi i} \int_{\delta} \frac{\exp(-\lambda)}{\lambda - B_{u^2}^{W,2}} d\lambda \right].$$

Ultimately from Theorem 8.8 and from (9.168), (9.170), we find that for $u \geq u_0$, $T \geq 1$,

$$(9.171) \quad \left| \text{Tr}_s \left[(N_{u^2}^V - N_{\mathbf{H}}) \frac{1}{2\pi i} \int_{\delta} \frac{\exp(-\lambda)}{\lambda - B_{u,T}^2} d\lambda \right] - \text{Tr}_s \left[N_{u^2}^W \frac{1}{2\pi i} \int_{\delta} \frac{\exp(-\lambda)}{\lambda - B_{u^2}^{W,2}} d\lambda \right] \right| \leq \frac{C}{T^{\delta}},$$

$$\left| \text{Tr}_s \left[N_{\mathbf{H}} \frac{1}{2\pi i} \int_{\delta} \frac{\exp(-\lambda)}{\lambda - B_{u,T}^2} d\lambda \right] - \frac{1}{2} \dim N_{Y/X} \right| - \left| \text{Tr}_s \left[\frac{1}{2\pi i} \int_{\delta} \frac{\exp(-\lambda)}{\lambda - B_{u^2}^{W,2}} d\lambda \right] \right| \leq \frac{C}{T^{\delta}}.$$

i.e., we obtain (9.16).

Take again N as before. By Theorem 9.30, the $O_{\ell, m, n}(T)$ are uniformly bounded. Using (9.166), we see that for $u \geq 1$, $T \geq T_0$,

$$(9.172) \quad \left| \text{Tr}_s \left[N \frac{1}{2\pi i} \int_{\delta} \frac{\exp(-\lambda)}{\lambda - B_{u,T}^2} d\lambda \right] - \sum_{0 \leq n \leq 4 \dim S} \mathbb{O}_{n,0,n}(T) \right| \leq \frac{C}{u}.$$

On the other hand, by [3, Theorem 9.19], for a given $T \geq T_0$,

$$(9.173) \quad \lim_{u \rightarrow +\infty} \text{Tr}_s \left[N \frac{1}{2\pi i} \int_{\delta} \frac{\exp(-\lambda)}{\lambda - B_{u,T}^2} d\lambda \right] = \text{Tr}_s \left[P_T N P_T \frac{1}{2\pi i} \int_{\delta} \frac{\exp(-\lambda)}{\lambda - \nabla_T^{H(X, \xi_{|X}),2}} d\lambda \right].$$

Since the spectrum of $\nabla_T^{H(X, \xi_{|X}),2}$ is reduced to 0, we can rewrite (9.173) in the form

$$(9.174) \quad \lim_{u \rightarrow +\infty} \text{Tr}_s \left[N \frac{1}{2\pi i} \int_{\delta} \frac{\exp(-\lambda)}{\lambda - B_{u,T}^2} d\lambda \right] = \text{Tr}_s \left[P_T N P_T \exp(-\nabla_T^{H(X, \xi_{|X}),2}) \right].$$

Using (9.172), (9.174), we get for $u \geq u_0$, $T \geq 1$,

$$(9.175) \quad \left| \text{Tr}_s \left[N \frac{1}{2\pi i} \int_{\delta} \frac{\exp(-\lambda)}{\lambda - B_{u,T}^2} d\lambda \right] - \text{Tr}_s \left[P_T N P_T \exp(-\nabla_T^{H(X, \xi_{|X}),2}) \right] \right| \leq \frac{C}{u}.$$

From (9.175), we get (9.17). The proof of Theorem 9.6 is completed. \square

9.15 Proof of Theorem 6.15

Let z be an odd Grassmann variable, which anticommutes with all the other odd variables. Put

$$(9.176) \quad A_{u,T}^0 = A_{u,T} + zN_{u^2}^V.$$

Then $C_{u,T}$ is a superconnection, with $\Lambda(T_{\mathbf{R}}^*S)$ replaced by $\Lambda(T_{\mathbf{R}}^*S) \widehat{\otimes} \Lambda(\mathbf{R}^*)$. Moreover, using Theorem 2.14, we get

$$(9.177) \quad A_{u,T}^{0,2} = A_{u,T}^2 + z \left(u \frac{\partial}{\partial u} A_{u,T}'' - u \frac{\partial}{\partial u} A_{u,T}' \right).$$

Also we can apply to the superconnection $A_{u,T}^0$ the techniques we used in Chapters 7 and 8 when dealing with $A_{u,T}$. In particular as in (7.35), put

$$(9.178) \quad \widetilde{A}_{u,T}^0 = \exp \left(-f^\alpha \frac{c(f_\alpha^{H,N_{Y/X}})}{\sqrt{2}u} \right) A_{u,T}^0 \exp \left(f^\alpha \frac{c(f_\alpha^{H,N_{Y/X}})}{\sqrt{2}u} \right).$$

By Theorem 7.17 and by (9.178),

$$(9.179) \quad \widetilde{A}_{u,T}^0 = \widetilde{A}_{u,T} + z(N_{\mathbf{V}}^X + i\omega^V(e_i, f_\alpha^{H,W}) \frac{c(e_i)f^\alpha}{u\sqrt{2}} + \frac{i\omega^V}{2u^2}(f_\alpha^{H,W}, f_\beta^{H,W})f^\alpha f^\beta).$$

By Theorem 8.5 and by (9.179), as $T \rightarrow +\infty$,

$$(9.180) \quad F_T k^{1/2} \widetilde{A}_{1,T}^0 k^{-1/2} F_T^{-1} = TV^+(y) + \sqrt{T}(D^{N_{Y/X}} + \widetilde{\nabla}_Z^\xi V(y)) + \mathfrak{B} + z\widetilde{N}_1^V + \frac{1}{\sqrt{T}}\mathcal{O}(|Z|^2 \partial^{N_{Y/X}} + |Z| \partial^Y + |Z| \partial^S + |Z| + |Z|^3).$$

By Theorem 8.8, we find that

$$(9.181) \quad \psi^{-1}p(\mathfrak{B} + z\widetilde{N}_1^V)p\psi = B_1^W + z(N_1^W + \frac{1}{2} \dim N_{Y/X}).$$

Finally by using Theorem 2.14 again, we get

$$(9.182) \quad (B_{u^2}^W + z(N_1^W + \frac{1}{2} \dim N_{Y/X}))^2 = B_{u^2}^{W,2} + z \left(u \frac{\partial}{\partial u} B_{u^2}^{W''} - u \frac{\partial}{\partial u} B_{u^2}^{W'} \right).$$

Now it is quite clear that the techniques used above also apply to the superconnection $A_{u,T}^0$. In particular we find that given $u_0 > 0$, there exists $C > 0$, $\delta \in]0, \frac{1}{2}]$, such that for $u \geq u_0$, $T \geq 1$,

$$(9.183) \quad \left| \text{Tr}_s \left[N_{\mathbf{H}} \exp(-B_{u,T}^2 - bz \left(u \frac{\partial}{\partial u} B_{u^2}^{V''} - u \frac{\partial}{\partial u} B_{u^2}^{V'} \right)) \right] - \frac{1}{2} \dim N_{Y/X} \text{Tr}_s \left[\exp(-B_{u^2}^{W,2} - bz \left(u \frac{\partial}{\partial u} B_{u^2}^{W''} - u \frac{\partial}{\partial u} B_{u^2}^{W'} \right)) \right] \right| \leq \frac{C}{T^\delta}.$$

By taking the components in (9.183) which are sums of forms of type $(p, p + 1)$ or $(p + 1, p)$, we get the first inequality in (6.79). The second inequality in (6.79) follows from Theorem 8.8 and from the techniques of the preceding Subsections.

The proof of Theorem 6.15 is completed.

9.16 Proof of Theorem 6.16

Using (9.177) and proceeding as in Section 9.15, we find that there exists $C \geq 0$ such that for $u \geq u_0, T \geq 1$,

$$(9.184) \quad \left| \text{Tr}_s \left[N_{\mathbf{H}} \exp \left(-B_{u,T}^2 - z \left(u \frac{\partial}{\partial u} B_{u^2}^{V''} - u \frac{\partial}{\partial u} B_{u^2}^{V'} \right) \right) \right] \right. \\ \left. - \text{Tr}_s \left[P_T N_{\mathbf{H}} P_T \exp \left(- \left(\nabla_T^{H(X, \xi|x)} + z P_T N_{\mathbf{V}}^X P_T \right)^2 \right) \right] \right| \leq \frac{C}{u}.$$

Also

$$(9.185) \quad \left(\nabla_T^{H(X, \xi|x)} + z P_T N_{\mathbf{V}}^X P_T \right)^2 = \left(\nabla_T^{H(X, \xi|x), 2} - z \nabla_T^{H(X, \xi|w)} P_T N_{\mathbf{V}}^X P_T \right).$$

From (9.184), (9.185), we get the first inequality in (6.80). The second inequality in (6.80) can be proved as before. \square

10. The asymptotics of the metric $g_T^{H(Y, \eta|_Y)}$ as $T \rightarrow +\infty$

Recall that $g_T^{H(X, \xi|_X)}$ is the metric induced by $\langle \cdot, \cdot \rangle_T$ on $H(X, \xi|_X)$, and that $g_T^{H(Y, \eta|_Y)}$ is the metric on $H(Y, \eta|_Y)$ associated to $g_T^{H(X, \xi|_X)}$ via the canonical identification $H(X, \xi|_X) \simeq H(Y, \eta|_Y)$.

The purpose of this Chapter is to prove Theorem 6.10, i.e. to calculate the asymptotics as $T \rightarrow +\infty$ of $g_T^{H(Y, \eta|_Y)}$ and its derivatives over S . In the case where S is reduced to a point, Theorem 6.10 was already established in [19, Theorem 10.9]. Here the main point is to show that the techniques of [19, Section 10] allow us to control the derivatives of the metric.

This Chapter is organized as follows. In Section 10.1, we lift sections of $\ker D^Y$ to sections of $\ker A_T^{(0)}$. In Section 10.2, we use the results of Section 10.1 to lift sections of $\ker D^Y$ to fibrewise harmonic sections of E with respect to $\langle \cdot, \cdot \rangle_T$. Finally in Section 10.3, we prove Theorem 6.10.

Here, we use the notation of Chapters 3, and 6-9.

We take $\varepsilon_0 > 0$ as in Chapter 7. As before we assume that V, W and S are compact. Also we may and we will assume that S is connected.

10.1 The lift of sections of $\ker D^Y$ to sections of $\ker A_T^{(0)}$

Let $Y = \bigcup_1^d Y_j$ be the decomposition of Y into nonempty connected components. Note that since S is connected, d is constant over S . However the labelling of the Y_j is only defined locally over S . By replacing S by a small compact neighborhood of $s_0 \in S$, we may as well assume that the decomposition $Y = \bigcup_1^d Y_j$ is defined globally over S . Let $W = \bigcup_1^d W_j$ be the corresponding decomposition of W .

For $1 \leq j \leq d$, set

$$(10.1) \quad B_{j, \varepsilon_0/2} = \{Z \in N_{Y_j/X, \mathbf{R}}, |Z| < \varepsilon_0/2\}.$$

As in Section 7.3, we identify $B_{j, \varepsilon_0/2}$ to a tubular neighborhood $\mathcal{U}_{j, \varepsilon_0/2}$ of W_j in V . Since $\mathcal{U}_{\varepsilon_0}$ is a tubular neighborhood of W in V , for $j \neq j'$, $\overline{\mathcal{U}}_{j, \varepsilon_0/2} \cap \overline{\mathcal{U}}_{j', \varepsilon_0/2} = \emptyset$.

For $1 \leq j \leq d$, let F_j be the vector bundle over S of smooth sections of $\Lambda(T^{*(0,1)}Y_j) \otimes \eta|_{Y_j}$ over Y_j , let D^{Y_j} be the restriction of D^Y to F_j . Then

$$(10.2) \quad F = \bigoplus_{j=1}^d F_j \quad , \quad D^Y = \bigoplus_{j=1}^d D^{Y_j} .$$

Also $\ker D^Y = \bigoplus \ker D^{Y_j}$, and for $1 \leq j \leq d$, $\ker D^{Y_j} \simeq H(Y_j, \eta|_{Y_j})$ is a smooth vector bundle on S . Let Q be the orthogonal projection from F^0 on $\ker D^Y$.

We establish the following extension of [19, Theorem 10.1].

Theorem 10.1 — For any $k \in \mathbf{N}$, for any smooth sections U_1, \dots, U_k of $T_{\mathbf{R}}V$, for any smooth section σ of $\ker D^{Y_j}$ ($1 \leq j \leq d$), and for any $q \in \mathbf{N}$, there exist $C > 0$ such that for $T \geq 1$,

$$(10.3) \quad \sup_{x \in V \setminus \mathcal{U}_{j, \varepsilon_0/2}} \left| \nabla_{U_1}^{\Lambda(T^{*(0,1)}X) \widehat{\otimes} \xi} \dots \nabla_{U_k}^{\Lambda(T^{*(0,1)}X) \widehat{\otimes} \xi} \tilde{P}_T J_T \sigma \right| (x) \leq \frac{C}{T^q} .$$

For any $k' \in \mathbf{N}$, for any smooth sections $U'_1, \dots, U'_{k'}$ of $T_{\mathbf{R}}W$, and any smooth section σ of $\ker D^Y$, there is $C > 0$ such that

$$(10.4) \quad \sup_{y \in W} \left| \nabla_{U'_1}^{\Lambda(T^{*(0,1)}Y) \widehat{\otimes} \eta} \dots \nabla_{U'_{k'}}^{\Lambda(T^{*(0,1)}Y) \widehat{\otimes} \eta} \left(Qr \tilde{P}_T (2^{\dim N_{Y/X}} \alpha_T) \right)^{1/2} J_T \sigma - \sigma \right| (y) \leq \frac{C}{\sqrt{T}} .$$

Proof. When S is a point, the case where $U_1, \dots, U_k \in T_{\mathbf{R}}X$, $U'_1, \dots, U'_{k'} \in T_{\mathbf{R}}Y$ was already considered in the proof of [19, Theorem 10.1].

Let c_2 be the positive constant constructed in Section 9.1. By definition

$$(10.5) \quad \text{Sp}(D^Y) \cap \{ \lambda \in \mathbf{C}, |\lambda| \leq \sqrt{c_2} \} \subset \{0\} .$$

Also by Theorem 9.1, for $T \geq T_0 \geq 1$,

$$(10.6) \quad \text{Sp}(A_T^{(0)}) \cap \{ \lambda \in \mathbf{C}, |\lambda| \leq \sqrt{c_2} \} \subset \{0\} .$$

Let δ be the circle in \mathbf{C} of center 0 and radius $\sqrt{c_2}$. Then for $T \geq T_0$,

$$(10.7) \quad \tilde{P}_T = \frac{1}{2\pi i} \int_{\delta} \frac{d\lambda}{\lambda - A_T^{(0)}} .$$

Using (10.7), it is not difficult to extend the arguments of [19] to obtain uniformity in $s \in S$ in the estimates of [19, Theorem 10.1], i.e. to get (10.3), (10.4) when $U_1, \dots, U_k \in T_{\mathbf{R}}X$, $U'_1, \dots, U'_{k'} \in T_{\mathbf{R}}Y$.

Take $\varepsilon > 0$ as in Theorem 9.14. Let $E^0(X \setminus \mathcal{U}_{j, \varepsilon})$ be the Hilbert bundle of sections of $\Lambda(T^{*(0,1)}X) \widehat{\otimes} \xi$ over $X \setminus \mathcal{U}_{j, \varepsilon}$ which are square-integrable. We equip $E^0(X \setminus \mathcal{U}_{j, \varepsilon})$ with the Hermitian product induced by the Hermitian product of E^0 .

We will show that if B is a smooth section of $T_{\mathbf{R}}S$, if σ is a smooth section of $\ker D^{Y_j}$,

$$(10.8) \quad \left\| \nabla_B^E \tilde{P}_T J_T \sigma \right\|_{E^0(X_j \setminus \mathcal{U}_{j,\varepsilon})} = \mathcal{O}(T^{-\infty}).$$

By (10.7),

$$(10.9) \quad \tilde{P}_T J_T \sigma = \frac{1}{2\pi i} \int_{\delta} (\lambda - A_T^{(0)})^{-1} J_T \sigma d\lambda.$$

To prove (10.8), we only need to show that uniformly in $\lambda \in \delta$,

$$(10.10) \quad \left\| \nabla_B^E (\lambda - A_T^{(0)})^{-1} J_T \sigma \right\|_{E^0(X \setminus \mathcal{U}_{j,\varepsilon})} = \mathcal{O}(T^{-\infty}).$$

In [19, proof of Theorem 10.1], for $\lambda \in \delta$, $T \geq T_0$, given $m \in \mathbf{N}$, an explicit construction of $s_m(\lambda, T) \in E$, $t_m(\lambda, T) \in E$ is given so that

$$(10.11) \quad \begin{aligned} t_m(\lambda, T) &= (\lambda - A_T^{(0)}) s_m(\lambda, T) - J_T \sigma, \\ s_m(\lambda, T) &= 0 \quad \text{on } V \setminus \mathcal{U}_{j,\varepsilon}, \\ \|t_m(\lambda, T)\|_{E^0} &= \mathcal{O}(T^{-m/2}). \end{aligned}$$

□

By (10.11),

$$(10.12) \quad (\lambda - A_T^{(0)})^{-1} J_T \sigma = s_m(\lambda, T) - (\lambda - A_T^{(0)})^{-1} t_m(\lambda, T).$$

From (10.11), it is clear that

$$(10.13) \quad \nabla_{B^H, V}^{\Lambda(T^{(0,1)} X) \otimes \xi} s_m(\lambda, T) = 0 \quad \text{on } V \setminus \mathcal{U}_{j,\varepsilon}.$$

So by (10.12), (10.13), we get on $V \setminus \mathcal{U}_{j,\varepsilon}$

$$(10.14) \quad \nabla_B^E (\lambda - A_T^{(0)})^{-1} J_T \sigma = \nabla_B^E (\lambda - A_T^{(0)})^{-1} t_m(\lambda, T).$$

Also

$$(10.15) \quad \begin{aligned} \nabla_B^E (\lambda - A_T^{(0)})^{-1} t_m(\lambda, T) &= (\lambda - A_T^{(0)})^{-1} \left[\nabla_B^E, A_T^{(0)} \right] \\ &\quad (\lambda - A_T^{(0)})^{-1} t_m(\lambda, T) + (\lambda - A_T^{(0)})^{-1} \nabla_B^E t_m(\lambda, T) \quad \text{on } V \setminus \mathcal{U}_{j,\varepsilon}. \end{aligned}$$

In [19, proof of Theorem 10.1], $t_m(\lambda, T)$ is constructed by an explicit universal algorithm, and is calculated in [19, eq. (10.19)]. It is then not difficult to obtain the estimate

$$(10.16) \quad \left\| \nabla_B^E t_m(\lambda, T) \right\|_{E^0} = \mathcal{O}(T^{-(m-1)/2}).$$

Clearly, $[\nabla_B^E, A_T^{(0)}]$ is a first order differential operator acting fibrewise. In particular for $T \geq \bar{T}$, $s \in E$,

$$(10.17) \quad \left\| [\nabla_B^E, A_T^{(0)}] s \right\|_{E^0} \leq C (\|s\|_{E^1} + T \|s\|_{E^0}) .$$

Also by [19, eq. (10.34)], if $T \geq T_0$, $\lambda \in \delta$, $s \in E$,

$$(10.18) \quad \left\| (\lambda - A_T^{(0)})^{-1} s \right\|_{E^1} \leq CT^{1/2} \|s\|_{E^0} .$$

By (10.15)-(10.18), we find that

$$(10.19) \quad \left\| \nabla_B^E (\lambda - A_T^{(0)})^{-1} t_m(\lambda, T) \right\|_{E^0} \leq CT^{-\frac{(m-2)}{2}} .$$

Using (10.14), (10.19), we obtain

$$(10.20) \quad \left\| \nabla_B^E (\lambda - A_T^{(0)})^{-1} J_T \sigma \right\|_{E^0(X \setminus \mathcal{U}_{j,\varepsilon})} \leq CT^{-\frac{(m-2)}{2}} .$$

Since m is arbitrary, we get (10.10). So we have established (10.8).

More generally, by an obvious recursion argument, using (10.11), we find that given $k \in \mathbf{N}$, if B_1, \dots, B_k are smooth sections of $T_{\mathbf{R}}S$,

$$(10.21) \quad \left\| \nabla_{B_1}^E \dots \nabla_{B_k}^E \tilde{P}_T J_T \sigma \right\|_{E^0(X \setminus \mathcal{U}_{j,\varepsilon})} = \mathcal{O}(T^{-\infty}) .$$

As in [19, Theorem 10.1], we will convert (10.21) into pointwise estimates. First by [19, eq. (10.37)], given $p \in \mathbf{N}$, there is $C_p > 0$ such that if $s \in E$,

$$(10.22) \quad \|s\|_{E^p} \leq CT^p (\|A_T^{(0)} s\|_{E^{p-1}} + \|s\|_{E^0}) .$$

Clearly

$$(10.23) \quad A_T^{(0)} \tilde{P}_T J_T \sigma = 0 .$$

Using (10.21) with $k = 0$, (10.22), (10.23) and a trivial truncation argument, we find easily that on $V \setminus \mathcal{U}_{j,\varepsilon(1+\frac{1}{4})}$, for $p \in \mathbf{N}$, the E^p norm of $\tilde{P}_T J_T \sigma$ is $\mathcal{O}(T^{-\infty})$. By Sobolev embedding, on $V \setminus \mathcal{U}_{j,\varepsilon(1+\frac{1}{2})}$, $\tilde{P}_T J_T \sigma$ and its fibrewise derivatives are $\mathcal{O}(T^{-\infty})$, which is a result already established in [19, proof of Theorem 10.1].

By (10.23), if B is a smooth section of $T_{\mathbf{R}}S$, then

$$(10.24) \quad \nabla_B^E A_T^{(0)} \tilde{P}_T J_T \sigma = 0 ,$$

and so,

$$(10.25) \quad [\nabla_B^E, A_T^{(0)}] \tilde{P}_T J_T \sigma + A_T^{(0)} \nabla_B^E \tilde{P}_T J_T \sigma = 0 .$$

Now $[\nabla_B^E, A_T^{(0)}]$ is a fibrewise first order differential operator. Using (10.21) with $k = 1$, (10.22), and also the previous estimates on the fibrewise derivatives of $\tilde{P}_T J_T \sigma$, we find that on $X \setminus \mathcal{U}_{j, \varepsilon(1 + \frac{1}{2} + \frac{1}{4})}$, $\nabla_B^E \tilde{P}_T J_T \sigma$ and its fibrewise derivatives are $\mathcal{O}(T^{-\infty})$.

By using (10.21) and by differentiating (10.25) again, we ultimately see that given $k \in \mathbb{N}$, if B_1, \dots, B_k are smooth sections of $T_{\mathbb{R}}S$, $\nabla_{B_1}^E \dots \nabla_{B_k}^E \tilde{P}_T J_T \sigma$ and its fibrewise derivatives are $\mathcal{O}(T^{-\infty})$ on $X \setminus \mathcal{U}_{j, 2\varepsilon}$. Finally recall formula (2.24) for ∇^E . Since $2\varepsilon \leq \varepsilon_0/2$, from the previous estimates, (10.3) follows trivially.

Now we will establish (10.4). Let $\alpha_{T,j}$ be the restriction of α_T to Y_j . Put

$$(10.26) \quad \begin{aligned} s'_m(\lambda, T) &= \left(2^{\dim N_{Y_j/X}} \alpha_{T,j} \right)^{1/2} s_m(\lambda, T), \\ t'_m(\lambda, T) &= \left(2^{\dim N_{Y_j/X}} \alpha_{T,j} \right)^{1/2} t_m(\lambda, T). \end{aligned}$$

By [19, eq. (10.25)], $s'_m(\lambda, T)$ has an explicit expression given by

$$(10.27) \quad s'_m(\lambda, T) = k^{-1/2} \rho F_T^{-1} \sum_{n=0}^{m+1} f_n(\lambda) T^{-n/2},$$

and moreover by [19, eq. (10.22)],

$$(10.28) \quad f_0(\lambda) = \frac{\psi\sigma}{\lambda}.$$

From (10.27), (10.28), we get

$$(10.29) \quad \frac{1}{2\pi i} \int_{\delta} s'_m(\lambda, T) d\lambda = k^{-1/2} \rho F_T^{-1} \left(\psi\sigma + \sum_{n=1}^{m+1} \int_{\delta} f_n(\lambda) d\lambda \quad T^{-n/2} \right).$$

Since on W , $k = 1$, $\rho = 1$,

$$(10.30) \quad Qr \left[\frac{1}{2\pi i} \int_{\delta} s'_m(\lambda, T) d\lambda \right] = \sigma + \sum_{n=1}^{m+1} Qr \int_{\delta} f_n(\lambda) d\lambda \quad T^{-n/2}.$$

As explained before, the construction of the $f_n(\lambda)$'s is given by an explicit algorithm. In particular, one sees easily that they depend smoothly on $s \in S$. By (10.30), we find that for $k \in \mathbb{N}$, if B_1, \dots, B_k are taken as before,

$$\nabla_{B_1}^F \dots \nabla_{B_k}^F \left(Qr \frac{1}{2\pi i} \int_{\delta} s'_m(\lambda, T) d\lambda - \sigma \right)$$

and its fibrewise derivatives of any order are $\mathcal{O}\left(\frac{1}{\sqrt{T}}\right)$.

In view of (10.9), (10.12), (10.30), to prove (10.4), we only need to establish a similar uniform estimate for $r(\lambda - A_T^{(0)})^{-1} t'_m(\lambda, T)$. By (10.11),

$$(10.31) \quad t'_m(\lambda, T) = (\lambda - A_T^{(0)}) s'_m(\lambda, T) - J_T (2^{\dim N_{Y_j/X}} \alpha_T)^{1/2} \sigma.$$

Again, as explained before, $t'_m(\lambda, T)$ is given by an explicit algorithm. By proceeding as in [19, eq. (10.32)], we find that given $p > 0$,

$$(10.32) \quad \left\| \nabla_{B_1}^E \dots \nabla_{B_k}^E t'_m(\lambda, T) \right\|_{E^p} \leq CT^{1/2(p+k-\dim N_{Y_j/X}-m)}.$$

By [19, eq. (10.38)], for $T \geq T_0$, $\lambda \in \delta$

$$(10.33) \quad \left\| (\lambda - A_T^{(0)})^{-1} s \right\|_{E^p} \leq CT^p \|s\|_{E^{p-1}}.$$

From (10.32) with $k = 0$ and from (10.33), we obtain

$$(10.34) \quad \left\| (\lambda - A_T^{(0)})^{-1} t'_m(\lambda, T) \right\|_{E^p} \leq CT^{p+1/2(p-\dim N_{Y_j/X}-m-1)}.$$

By taking $p > 2 \dim X$ and using fibrewise Sobolev embedding, we deduce that given $q \in \mathbf{N}$, for $m \in \mathbf{N}$ large enough, $(\lambda - A_T^{(0)})^{-1} t'_m(\lambda, T)$ and its fibre derivatives of order $\leq q$ are $\mathcal{O}(\frac{1}{\sqrt{T}})$. In particular

$$(10.35) \quad \left| r(\lambda - A_T^{(0)})^{-1} t'_m(\lambda, T) \right| \leq \frac{C}{\sqrt{T}}.$$

Since Q is fibrewise regularizing, from (10.35), we see that $Qr(\lambda - A_T^{(0)})^{-1} t'_m(\lambda, T)$ and its fibre derivatives are $\mathcal{O}(\frac{1}{\sqrt{T}})$.

Clearly

$$(10.36) \quad \nabla_B^E (\lambda - A_T^{(0)})^{-1} t'_m(\lambda, T) = (\lambda - A_T^{(0)})^{-1} \left[\nabla_B^E, A_T^{(0)} \right] (\lambda - A_T^{(0)})^{-1} t'_m(\lambda, T) + (\lambda - A_T^{(0)})^{-1} \nabla_B^E t'_m(\lambda, T).$$

By (10.32), (10.33),

$$(10.37) \quad \left\| (\lambda - A_T^{(0)})^{-1} \nabla_B^E t'_m(\lambda, T) \right\|_{E^p} \leq CT^{p+\frac{1}{2}(p-\dim N_{Y_j/X}-m)}.$$

Since $\left[\nabla_B^E, A_T^{(0)} \right]$ is a fibrewise first order differential operator, by (10.32), (10.33), we get

$$(10.38) \quad \left\| (\lambda - A_T^{(0)})^{-1} \left[\nabla_B^E, A_T^{(0)} \right] (\lambda - A_T^{(0)})^{-1} t'_m(\lambda, T) \right\|_{E^p} \leq CT^{2p+1+\frac{1}{2}(p-1-\dim N_{Y_j/X}-m)}.$$

So using (10.36)-(10.38), we find that

$$(10.39) \quad \left\| \nabla_B^E (\lambda - A_T^{(0)})^{-1} t'_m(\lambda, T) \right\|_{E^p} \leq CT^{2p+1/2+\frac{1}{2}(p-\dim N_{Y_j/X}-m)}.$$

By proceeding as before, we deduce that given $q \in \mathbb{N}$, for m large enough, $\nabla_B^E(\lambda - A_T^{(0)})^{-1}t'_m(\lambda, T)$ and its fibre derivatives of order $\leq q$ are $\mathcal{O}(\frac{1}{\sqrt{T}})$. Recall that after (10.34), we found that for $m \in \mathbb{N}$ large enough, the fibre derivatives of $(\lambda - A_T^{(0)})^{-1}t'_m(\lambda, T)$ are also $\mathcal{O}(\frac{1}{\sqrt{T}})$. We thus find that on W ,

$$(10.40) \quad \left| \nabla_B^F r(\lambda - A_T^{(0)})^{-1}t'_m(\lambda, T) \right| \leq \frac{C}{\sqrt{T}}.$$

Since Q and $[\nabla_B^F, Q]$ are fibrewise regularizing, we deduce from (10.40) that $\nabla_B^F Qr(\lambda - A_T^{(0)})^{-1}t'_m(\lambda, T)$ and its fibre derivatives are $\mathcal{O}(\frac{1}{\sqrt{T}})$.

By combining the previous estimates and a simple iteration argument, we get (10.4). The proof of our Theorem is completed. \square

10.2 The lift of sections of $\ker D^Y$ to harmonic forms in E for the metric $\langle \cdot, \cdot \rangle_T$

Recall that by (6.12),

$$(10.41) \quad P_T = T^{N_{\mathbb{H}}} \tilde{P}_T T^{-N_{\mathbb{H}}}.$$

Definition 10.2. For $T > 0$, let B_T be the linear map

$$(10.42) \quad \sigma \in F \rightarrow B_T \sigma(y, Z) = k^{-1/2}(y, Z) \rho(Z) \exp \left\{ T\theta - T \frac{|Z|^2}{2} \right\} \sigma(y) \in E.$$

Observe that

$$(10.43) \quad B_T \sigma = T^{N_{\mathbb{H}}} (2^{\dim N_{Y/X}} \alpha_T)^{1/2} J_T \sigma.$$

Also recall that $\nabla^{H(Y, \eta|_Y)}$ is a connection on $H(Y, \eta|_Y) \simeq \ker D^Y$.

Now we extend [19, Theorem 10.3].

Theorem 10.3 — For $T > 0$ let C_T be the linear map

$$(10.44) \quad \sigma \in \ker(D^Y) \rightarrow C_T \sigma = Qr P_T B_T \sigma \in \ker(D^Y).$$

For any $k \in \mathbb{N}$, if B_1, \dots, B_k are smooth sections of $T_{\mathbb{R}}S$, there exists $C > 0$ such that for $T \geq 1$,

$$(10.45) \quad \left\| \nabla_{B_1}^{H(Y, \eta|_Y)} \dots \nabla_{B_k}^{H(Y, \eta|_Y)} (C_T - 1) \right\| \leq \frac{C}{\sqrt{T}}.$$

If k, B_1, \dots, B_k are taken as before, given $q \in \mathbb{N}$, there exists $C_q > 0$ such that if $1 \leq j \leq d$, if $T \geq 1$, and if $\sigma \in \ker(D^{Y_j})$, then

$$(10.46) \quad \sup_{y \in W \setminus W_j} \left| \left(\nabla_{B_1}^{H(Y, \eta|_Y)} \dots \nabla_{B_k}^{H(Y, \eta|_Y)} C_T \right) \sigma(y) \right| \leq \frac{C_q}{T^q} \|\sigma\|_{F^0}.$$

There exists $T_0 \geq 1$ such that for $T \geq T_0$, C_T is invertible and C_T^{-1} is uniformly bounded. Then for $T \geq T_0$, $s \in K$,

$$(10.47) \quad P_T s = P_T B_T C_T^{-1} Q r s.$$

If k, B_1, \dots, B_k are taken as before, if $q \in \mathbf{N}$, there exists $C_q > 0$ for $T \geq T_0$, if $\sigma \in \ker(D^{Y_j})$,

$$(10.48) \quad \sup_{y \in W \setminus W_j} \left| \left(\nabla_{B_1}^{H(Y, \eta|Y)} \dots \nabla_{B_k}^{H(Y, \eta|Y)} C_T^{-1} \right) \sigma(y) \right| \leq \frac{C_q}{T^q} \|\sigma\|_{F^0}.$$

Proof. By (10.41), (10.43),

$$(10.49) \quad C_T \sigma = Q r \tilde{P}_T (2^{\dim N_{Y/X}} \alpha_T)^{1/2} J_T \sigma.$$

So (10.45) follows from (10.4). Equation (10.46) follows from (10.3).

By (10.45), for $T \geq 1$ large enough, C_T is invertible, and C_T^{-1} is uniformly bounded together with its derivatives. Then equation (10.47) was established in [19, Theorem 10.3].

Recall that $\ker D^Y = \bigoplus_{j=1}^d \ker D^{Y_j}$. Let D_T, E_T be the diagonal and non diagonal parts of C_T with respect to this splitting. Using (10.46), we find that

$$(10.50) \quad \left\| \nabla_{B_1}^{H(Y, \eta|Y)} \dots \nabla_{B_k}^{H(Y, \eta|Y)} E_T \right\| = \mathcal{O}(T^{-\infty}).$$

Also by (10.45), for $T \geq 1$ large enough, D_T is invertible and moreover

$$(10.51) \quad C_T^{-1} = D_T^{-1} (1 + E_T D_T^{-1})^{-1}.$$

By (10.50), (10.51), we see that if E'_T is the non diagonal part of C_T^{-1} , then

$$(10.52) \quad \left\| \nabla_{B_1}^{H(Y, \eta|Y)} \dots \nabla_{B_k}^{H(Y, \eta|Y)} E'_T \right\| = \mathcal{O}(T^{-\infty}).$$

Since the norms of finite dimensional bundles are equivalent, from (10.52), we get (10.48). The proof of our Theorem is completed. \square

Recall that by Theorem 3.3 and by (6.23),

$$(10.53) \quad H^*(E, \bar{\partial}^X + v) \simeq \bigoplus_1^d H^*(Y_j, \eta|_{Y_j}).$$

Definition 10.4. For $1 \leq j \leq d$, let $H_j^*(E, \bar{\partial}^X + v)$ be the subbundle of $H^*(E, \bar{\partial}^X + v)$ corresponding to $H^*(Y_j, \eta|_{Y_j})$ via the canonical isomorphism (10.53).

Definition 10.5. For $1 \leq j \leq d$, let $K(j)$ be the subbundle of K corresponding to $H_j^*(E, \bar{\partial}^X + v)$ via the canonical isomorphism $K \simeq H^*(E, \bar{\partial}^X + v)$.

For $s \in E$, $1 \leq j \leq d$, let $r_{j,s} \in F_j$ be the restriction of rs to Y_j . For $1 \leq j \leq d$, let Q_j be the orthogonal projection operator from F^0 on $K_j' = \ker(D^{Y_j})$.

First we recall the result of [19, Proposition 10.6].

Proposition 10.6 — For $1 \leq j \leq d$, the following identity holds

$$(10.54) \quad K(j) = \{s \in K \text{ , } Q_{j'}r_{j'}s = 0 \text{ for } j' \neq j\} .$$

Now we establish the obvious extension of [19, Theorem 10.7].

Theorem 10.7 — Let $k \in \mathbf{N}$, let U_1, \dots, U_k be smooth sections of $T_{\mathbf{R}}V$. If $1 \leq j \leq d$, if s is a smooth section of $K(j)$, if $q \in \mathbf{N}$, there exists $C_q > 0$ such that for $T \geq 1$,

$$(10.55) \quad \sup_{x \in W \setminus \mathcal{U}_{j, \varepsilon_0/2}} \left| \nabla_{U_1}^{\Lambda(T^{*(0,1)}X) \otimes \xi} \dots \nabla_{U_k}^{\Lambda(T^{*(0,1)}X) \otimes \xi} P_T s \right| (x) \leq \frac{C_q}{T^q} .$$

Proof. By Theorem 10.3, for $T \geq 1$ large enough, if $s \in K(j)$,

$$(10.56) \quad P_T s = P_T B_T C_T^{-1} Q_r s .$$

By Proposition 10.6, $Q_r s$ vanishes except on W_j . Therefore by (10.41)-(10.43), (10.56), for $T \geq 1$ large enough,

$$(10.57) \quad P_T s = \sum_{j'=1}^d T^{N_H} \tilde{P}_T \left(2^{\dim N_{Y_{j'}/X}} \alpha_{T, j'} \right)^{1/2} J_T Q_{j'} C_T^{-1} Q_{j'} r_j s .$$

Clearly Q_j depends smoothly on $s \in S$. By Theorem 10.3, for $T \geq 1$ large enough, C_T^{-1} is bounded together with its derivatives. By using Theorem 10.1, we find that in the right-hand side of (10.57), the term corresponding to $j' = j$ verifies the bound (10.55).

By Theorem 10.3, if we fix $j' \neq j$, $Q_{j'} C_T^{-1} Q_{j'} r_j s$ and its derivatives of arbitrary order with respect to $\nabla^{H(Y, \eta|_Y)}$ are $\mathcal{O}(T^{-\infty})$. By Theorem 10.1, $\tilde{P}_T J_T Q_{j'} C_T^{-1} Q_{j'} r_j s$ and its derivatives are $\mathcal{O}(T^{-\infty})$ on $V \setminus \mathcal{U}_{j', \varepsilon_0/2}$. However this argument excludes $\mathcal{U}_{j', \varepsilon_0/2}$ itself. Still, we can reproduce the proof of Theorem 10.1, with $j = j'$, and $\sigma = Q_{j'} C_T^{-1} Q_{j'} r_j s$. Then $t'_m(\lambda, T)$ is estimated exactly as in the proof of Theorem 10.1. Here, since σ and its derivatives are $\mathcal{O}(T^{-\infty})$, it is trivial to verify that $s'_m(\lambda, T)$ and its derivatives are also $\mathcal{O}(T^{-\infty})$. This way, we find that for $j' \neq j$, $T^{N_H} \tilde{P}_T \left(2^{\dim N_{Y_{j'}/X}} \alpha_{T, j'} \right)^{1/2} J_T Q_{j'} C_T^{-1} Q_{j'} r_j s$ and its derivatives are $\mathcal{O}(T^{-\infty})$ on W .

The proof of our Theorem is completed. □

10.3 Proof of Theorem 6.10

By definition, if s, s' are smooth sections of $K(j)$ and $K(j')$ respectively, then

$$\begin{aligned}
 \langle P_T s, P_T s' \rangle_T(x) &= \langle T^{-N_{\mathbf{H}}} P_T s, T^{-N_{\mathbf{H}}} P_T s' \rangle(x) \\
 (10.58) \qquad \qquad \qquad &= \langle \tilde{P}_T T^{-N_{\mathbf{H}}} s, T^{-N_{\mathbf{H}}} P_T s' \rangle(x) \\
 &= \langle T^{-N_{\mathbf{H}}} P_T s, \tilde{P}_T T^{-N_{\mathbf{H}}} s' \rangle(x).
 \end{aligned}$$

Also if $\|\tilde{P}_T\|$ is the norm of \tilde{P}_T with respect to $\langle \cdot, \cdot \rangle$,

$$(10.59) \qquad \qquad \qquad \|\tilde{P}_T\| \leq 1.$$

Using Theorem 10.7 and (10.58), (10.59), we recover the result of [19, Theorem 10.9] that if $j \neq j'$

$$(10.60) \qquad \qquad \qquad \langle P_T s, P_T s' \rangle_T = \mathcal{O}(T^{-\infty}).$$

Also if $B \in T_{\mathbf{R}}S$, by (10.7),

$$(10.61) \qquad \nabla_B^E \tilde{P}_T = \frac{1}{2\pi i} \int_{\delta} (\lambda - A_T^{(0)})^{-1} [\nabla_B^E, A_T^{(0)}] (\lambda - A_T^{(0)})^{-1} d\lambda.$$

By (10.17), (10.18), (10.59), (10.61), we get

$$(10.62) \qquad \qquad \qquad \|\nabla_B^E \tilde{P}_T\| \leq CT.$$

By (10.58),

$$\begin{aligned}
 B_1^{H,V} \langle P_T s, P_T s' \rangle_T(x) &= \langle \nabla_B^E (\tilde{P}_T T^{-N_{\mathbf{H}}} s), T^{-N_{\mathbf{H}}} P_T s' \rangle(x) \\
 (10.63) \qquad \qquad \qquad &+ \langle \tilde{P}_T T^{-N_{\mathbf{H}}} s, \nabla_B^E (T^{-N_{\mathbf{H}}} P_T s') \rangle(x) \\
 &= \langle \nabla_B^E (T^{-N_{\mathbf{H}}} P_T s), \tilde{P}_T T^{-N_{\mathbf{H}}} s' \rangle(x) \\
 &+ \langle T^{-N_{\mathbf{H}}} P_T s, \nabla_B^E (\tilde{P}_T T^{-N_{\mathbf{H}}} s') \rangle(x).
 \end{aligned}$$

Using (10.59), (10.61)-(10.63) and Theorem 10.7, we find that if $j \neq j'$,

$$(10.64) \qquad \qquad \qquad \nabla_B \langle P_T s, P_T s' \rangle_T = \mathcal{O}(T^{-\infty}).$$

More generally, if $j \neq j'$, if B_1, \dots, B_k are smooth sections of $T_{\mathbf{R}}S$, the same argument as in (10.63) shows that

$$(10.65) \qquad \qquad \qquad \nabla_{B_1} \dots \nabla_{B_k} \langle P_T s, P_T s' \rangle_T = \mathcal{O}(T^{-\infty}).$$

Take now $s \in K(j)$. Then by Theorem 10.3, for $T \geq 1$ large enough,

$$(10.66) \quad \langle P_T s, P_T s \rangle_T = \langle P_T B_T C_T^{-1} Q r s, B_T C_T^{-1} Q r s \rangle_T .$$

Equivalently by (10.41)-(10.43), (10.65),

$$(10.67) \quad \langle P_T s, P_T s \rangle_T = \left\| \tilde{P}_T T^{-N_H} B_T C_T^{-1} Q r s \right\|_{E^0}^2 .$$

Take $\sigma \in K(j)$. We define $s'_m(\lambda, T), t'_m(\lambda, T)$, which are associated to σ as in (10.26). We will estimate

$$(10.68) \quad \left\| \tilde{P}_T T^{-N_H} B_T \sigma \right\|_{E^0}^2 = \left\| \frac{1}{2\pi i} \int_{\delta} \left[s'_m(\lambda, T) - (\lambda - A_T^{(0)})^{-1} t'_m(\lambda, T) \right] d\lambda \right\|_{E^0}^2 .$$

Using (10.34), (10.39) and more generally the extension of (10.39) to arbitrary $k \in \mathbf{N}$ (where k counts the number of derivatives $\nabla_{B_1}^E, \dots, \nabla_{B_k}^E$), we find that for $k \in \mathbf{N}$, $q \in \mathbf{N}$, for m large enough, $(\lambda - A_T^{(0)})^{-1} t'_m(\lambda, T)$ and its derivatives on V of order $\leq k$ are $\mathcal{O}(T^{-q})$. Using (10.29), one finds easily that a for given $q \in \mathbf{N}$, for m large enough, $\left\langle \int_{\delta} s'_m(\lambda, T) d\lambda, \int_{\delta} (\lambda - A_T^{(0)})^{-1} t'_m(\lambda, T) d\lambda \right\rangle$ and its derivatives of order $\leq k$ on S are $\mathcal{O}(T^{-q})$. Finally, by (10.29)

$$(10.69) \quad \left\| \frac{1}{2\pi i} \int_{\delta} s'_m(\lambda, T) d\lambda \right\|_{E^0}^2 = \frac{1}{T^{\dim N_{Y_j/X}}} \int_Y \frac{dv_{Y_j}(y)}{(2\pi)^{\dim Y}} \int_{N_{Y_j/X}} \rho^2\left(\frac{Z}{\sqrt{T}}\right) \left\| \psi\sigma + \sum_{n=1}^{m+1} \frac{1}{2\pi i} \int_{\delta} f_n(\lambda) d\lambda \right\|_{E^0}^2 T^{-n/2} (y, Z) \frac{dv_{N_{Y_j/X}}(Z)}{(2\pi)^{\dim N_{Y_j/X}}} .$$

From the previous considerations, one deduces that for any $k \in \mathbf{N}$, $T^{\dim N_{Y_j/X}} \left\| \frac{1}{2\pi i} \int_{\delta} s'_m(\lambda, T) d\lambda \right\|_{E^0}^2 - \|\sigma\|_{F^0}^2$ and its derivatives on S of order $\leq k$ are $\mathcal{O}(\frac{1}{\sqrt{T}})$. Therefore as $T \rightarrow +\infty$, $T^{\dim N_{Y_j/X}} \left\| \tilde{P}_T T^{-N_H} B_T \sigma \right\|_{E^0}^2 - \|\sigma\|_{F^0}^2$ and its derivatives on S are $\mathcal{O}(\frac{1}{\sqrt{T}})$.

Using Theorem 10.3 and (10.67), we see that if $s \in K(j)$, $T^{\dim N_{Y_j/X}} \langle P_T s, P_T s \rangle_T - \langle Q r s, Q r s \rangle_{F^0}$ and its derivatives on S are $\mathcal{O}(\frac{1}{\sqrt{T}})$.

The proof of Theorem 6.10 is completed. □

11. The analysis of the two parameter semi-group $\exp(-A_{u,T}^2)$ in the range $u \in]0, 1]$, $T \in [0, \frac{1}{u}]$

The purpose of this Chapter is to prove Theorems 6.7 and 6.17. The main point of Theorem 6.7 is to show the existence of $C > 0$, $\gamma \in]0, 1]$ such that for $u \in]0, 1]$, $0 \leq T \leq 1/u$, then

$$\left| \Phi \operatorname{Tr}_s [N_{\mathbf{H}} \exp(-A_{u,T}^2)] - \int_X \operatorname{Td}(TX, g^{TX}) \Phi \operatorname{Tr}_s [N_{\mathbf{H}} \exp(-C_{T^2}^2)] \right| \leq C(u(1+T))^\gamma.$$

This Chapter is the obvious extension of [19, Section 11], where Theorem 6.7 was established when S is a point.

To establish this result, the main idea is to replace $A_{u,T}$ by $\tilde{A}_{u,T}$, and to apply to $\tilde{A}_{u,T}^2$ the functional analytic machinery of [19, Section 11]. Of course, the local index techniques used in [19] in the case of a single fibre, are now replaced by relative local index techniques. We follow the approach by Berline-Getzler-Vergne [3] to the proof of the relative local index theorem of [4]. This permits us to apply to the present problem the techniques of [19, Section 11], to which the reader is referred when necessary.

This Chapter is organized as follows. In Section 11.1, we prove (6.20), which is the easy part of Theorem 6.7. In Section 11.2, we show that the proof of Theorem 6.7 is local on the fibres X . In Sections 11.3 and 11.4, we construct a coordinate system near W and a trivialization of $\pi_V^* \Lambda(T_{\mathbf{R}}^* S) \hat{\otimes} \Lambda(T^{*(0,1)} X) \hat{\otimes} \xi$. In Section 11.5, we introduce the conjugate superconnection $\tilde{B}_{u^2}^V$, and we calculate the Taylor expansion of $\tilde{B}_{u^2}^{V,2}$ as $u \rightarrow 0$ in the given trivialization. In Section 11.6, we reduce the proof of Theorem 6.7 to an equivalent problem on $(T_{\mathbf{R}} X)_{y_0}$ ($y_0 \in W$). In Section 11.7, and following [3], we make a Getzler rescaling on the operator $\tilde{A}_{u,T}^2$, and in Section 11.8, we describe certain key algebraic features of the new rescaled operator $L_{y_0,T}^{3,Z_0/T}$. In Section 11.9, we introduce graded Sobolev with weights. In Section 11.10, we show briefly how the results of the previous Subsections permit us to reduce the proof of Theorem 6.7 to

the problem already considered in [19, Section 11]. Finally in Section 11.11, we show how to prove Theorem 6.17 along the same lines as Theorem 6.7.

Here, we use the notation of Chapters 3 and 6-9.

11.1 The limit as $u \rightarrow 0$ of $\Phi \text{Tr}_s [N_{\mathbf{H}} \exp(-A_{u,T}^2)]$

For $u > 0, T > 0$, let $P_{u,T}(x, x')$ ($x, x' \in X$) be the smooth kernel of $\exp(-A_{u,T}^2)$ with respect to $\frac{dv_X(x')}{(2\pi)^{\dim X}}$.

If $\alpha \in \Lambda(T_{\mathbf{R}}^*V)$, if $U_1, \dots, U_{2 \dim X} \in T_{\mathbf{R}}X$, then $i_{U_1} \dots i_{U_{2 \dim X}} \alpha \in \Lambda(T_{\mathbf{R}}^*S)$. Let $\alpha^{\max} \in \Lambda(T_{\mathbf{R}}^*S)$ be such that

$$(11.1) \quad i_{U_1} \dots i_{U_{2 \dim X}} \alpha = (i_{U_1} \dots i_{U_{2 \dim X}} dv_X) \alpha^{\max}.$$

In particular, if α is a smooth section of $\Lambda(T_{\mathbf{R}}^*V)$, the integral along the fibre $\int_X \alpha$ is given by

$$(11.2) \quad \int_X \alpha = \int_X \alpha^{\max} dv_X.$$

Proposition 11.1 — *Let $T_0 \in [0, +\infty[$. There exists $C > 0$ such that for any $u \in]0, 1]$, $T \in [0, T_0]$, then*

$$(11.3) \quad \left| \Phi \text{Tr}_s [N_{\mathbf{H}} \exp(-A_{u,T}^2)] - \int_X \text{Td}(TX, g^{TX}) \Phi \text{Tr}_s [N_{\mathbf{H}} \exp(-C_{T^2}^2)] \right| \leq Cu,$$

$$\left| \Phi \text{Tr}_s [N_{\mathbf{H}} \exp(-A_{u,T}^2)] - \Phi \text{Tr}_s [N_{\mathbf{H}} \exp(-A_{u,0}^2)] \right| \leq CT.$$

Proof. By using the local families index theorem of [4] as in [14, Theorem 2.16], one finds easily that for any $T \geq 0, x \in V$, as $u \rightarrow 0$,

$$(11.4) \quad \Phi \text{Tr}_s [N_{\mathbf{H}} P_{u,T}(x, x)] \frac{dv_X(x)}{(2\pi)^{\dim X}} \rightarrow \left\{ \text{Td}(TX, g^{TX}) \Phi \text{Tr}_s [N_{\mathbf{H}} \exp(-C_{T^2}^2)] \right\}_x^{\max}.$$

Take $T_0 \geq 0$. The arguments in [4] show that there exists $C > 0$ such that for $u \in]0, 1]$, $T \in [0, T_0], x \in V$,

$$(11.5) \quad \left| \Phi \text{Tr}_s [N_{\mathbf{H}} P_{u,T}(x, x)] \frac{dv_X(x)}{(2\pi)^{\dim X}} - \left\{ \text{Td}(TX, g^{TX}) \Phi \text{Tr}_s [N_{\mathbf{H}} \exp(-C_{T^2}^2)] \right\}_x^{\max} \right| \leq Cu.$$

Finally

$$(11.6) \quad \Phi \text{Tr}_s [N_{\mathbf{H}} \exp(-A_{u,T}^2)] = \int_X \Phi \text{Tr}_s [N_{\mathbf{H}} P_{u,T}(x, x)] \frac{dv_X(x)}{(2\pi)^{\dim X}}.$$

□

The first inequality in (11.3) follows from (11.5), (11.6).

Also

$$(11.7) \quad \frac{\partial}{\partial T} \operatorname{Tr}_s [N_{\mathbf{H}} \exp(-A_{u,T}^2)] = \frac{\partial}{\partial b} \{ \operatorname{Tr}_s [N_{\mathbf{H}} \exp(-A_{u,T}^2 - b[A_{u,T}, V])] \}_{b=0} .$$

The arguments of [4], [14] show that for $T \leq T_0$, as $u \rightarrow 0$, the right-hand side of (11.7) remains uniformly bounded. Thus we get the second inequality in (11.3). \square

11.2 Localization of the problem

Let a^X (resp. a^Y) be the inf of the injectivity radius of the fibres X (resp. Y). We take $\varepsilon_0 > 0$ as in Section 7.3. Let $\varepsilon \in \mathbf{R}_+$ be such that $0 < \varepsilon \leq \frac{1}{8} \inf(a^X, a^Y, \varepsilon_0)$. If $x \in V$, let $B^X(x, \alpha)$ be the open ball of center x and radius α .

Let f be a smooth even function defined on \mathbf{R} with values in $[0, 1]$, such that

$$(11.8) \quad \begin{aligned} f(t) &= 1 \text{ for } |t| \leq \alpha/2, \\ &0 \text{ for } |t| \geq \alpha. \end{aligned}$$

Set

$$(11.9) \quad g(t) = 1 - f(t).$$

Definition 11.2. For $u \in]0, 1]$, $a \in \mathbf{C}$, set

$$(11.10) \quad \begin{aligned} F_u(a) &= \int_{-\infty}^{+\infty} \exp(it a \sqrt{2}) \exp\left(\frac{-t^2}{2}\right) f(ut) \frac{dt}{\sqrt{2\pi}}, \\ G_u(a) &= \int_{-\infty}^{+\infty} \exp(it a \sqrt{2}) \exp\left(\frac{-t^2}{2}\right) g(ut) \frac{dt}{\sqrt{2\pi}}. \end{aligned}$$

Clearly

$$(11.11) \quad F_u(a) + G_u(a) = \exp(-a^2).$$

The functions $F_u(a), G_u(a)$ are even holomorphic functions. Therefore there exist holomorphic functions $\tilde{F}_u(a), \tilde{G}_u(a)$ such that

$$(11.12) \quad \begin{aligned} F_u(a) &= \tilde{F}_u(a^2) \\ G_u(a) &= \tilde{G}_u(a^2). \end{aligned}$$

From (11.11), (11.12), we get

$$(11.13) \quad \tilde{F}_u(a) + \tilde{G}_u(a) = \exp(-a).$$

The restrictions of F_u, G_u to \mathbf{R} lie in $S(\mathbf{R})$. Therefore the restrictions of \tilde{F}_u, \tilde{G}_u to \mathbf{R} also lie in $S(\mathbf{R})$.

From (11.13), we deduce that

$$(11.14) \quad \exp(-A_{u,T}^2) = \tilde{F}_u(A_{u,T}^2) + \tilde{G}_u(A_{u,T}^2).$$

Theorem 11.3 — *There exist $c > 0, C > 0$ such that for $u \in]0, 1], T \geq 0$, then*

$$(11.15) \quad \left| \text{Tr}_s \left[N_{\mathbf{H}} \tilde{G}_u(A_{u,T}^2) \right] \right| \leq c \exp \left(\frac{-C}{u^2} \right).$$

Proof. Set

$$(11.16) \quad H_u(a) = \int_{-\infty}^{+\infty} \exp(it\sqrt{2}a) \exp\left(\frac{-t^2}{2u^2}\right) g(t) \frac{dt}{u\sqrt{2\pi}}.$$

Then

$$(11.17) \quad G_u(a) = H_u\left(\frac{a}{u}\right).$$

By [19, eq. (13.23)], we find that for any $c \in \mathbf{R}_+, m \in \mathbf{N}$, there exist $c_m > 0, C_m > 0$ such that

$$(11.18) \quad \sup_{\substack{a \in \mathbf{C} \\ |\text{Im}(a)| \leq c}} |a|^m |H_u(a)| \leq c_m \exp \left(\frac{-C_m}{u^2} \right).$$

Again there is a holomorphic function $\tilde{H}_u(a)$ such that

$$(11.19) \quad H_u(a) = \tilde{H}_u(a^2)$$

and so by (11.17), (11.19)

$$(11.20) \quad \tilde{G}_u(a) = \tilde{H}_u\left(\frac{a}{u^2}\right).$$

Let Δ' be the contour in \mathbf{C}

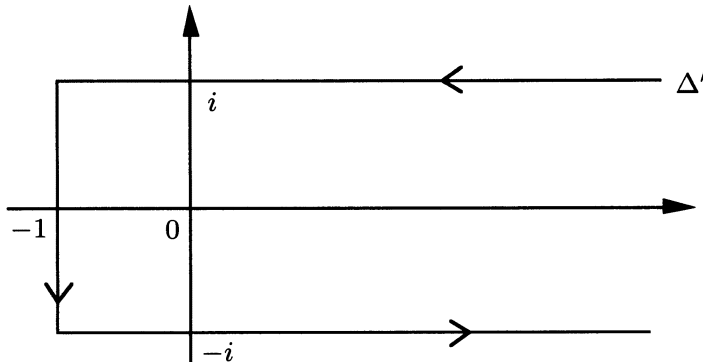

From (11.18), we deduce that

$$(11.21) \quad \sup_{a \in \Delta'} |a|^m \left| \tilde{H}_u(a) \right| \leq c \exp \left(\frac{-C}{u^2} \right).$$

Let $\tilde{H}_{u,p}(a)$ be a holomorphic function such that

$$(11.22) \quad \begin{cases} \lim_{a \rightarrow +\infty} \tilde{H}_{u,p}(a) = 0, \\ \frac{\tilde{H}_{u,p}^{(p-1)}(a)}{(p-1)!} = \tilde{H}_{u,p}(a). \end{cases}$$

By (11.18), we see that for any $m \in \mathbf{N}$,

$$(11.23) \quad \sup_{a \in \Delta'} |a|^m \left| \tilde{H}_{u,p}(a) \right| \leq c \exp \left(\frac{-C}{u^2} \right).$$

By Proposition 9.3 and by (11.20),

$$(11.24) \quad \text{Tr}_s \left[N_{\mathbf{H}} \tilde{G}_u(A_{u,T}^2) \right] = \psi_u \text{Tr}_s \left[N_{\mathbf{H}} \tilde{H}_u(A_{T/u}^2) \right].$$

Also

$$(11.25) \quad \text{Tr}_s \left[N_{\mathbf{H}} \tilde{H}_u(A_{T/u}^2) \right] = \text{Tr}_s \left[N_{\mathbf{H}} \tilde{H}_u(\tilde{A}_{T/u}^2) \right].$$

Clearly

$$\tilde{H}_u(\tilde{A}_{T/u}^2) = \frac{1}{2\pi i} \int_{\Delta'} \frac{\tilde{H}_u(\lambda)}{\lambda - \tilde{A}_{T/u}^2} d\lambda.$$

Equivalently

$$(11.26) \quad \tilde{H}_u(\tilde{A}_{T/u}^2) = \frac{1}{2\pi i} \int_{\Delta'} \frac{\tilde{H}_{u,p}(\lambda)}{(\lambda - \tilde{A}_{T/u}^2)^p} d\lambda.$$

Using (11.21), (11.26) and proceeding as in Chapter 9, we find easily that for $u \in]0, 1]$, $T \geq 1$,

$$(11.27) \quad \left| \text{Tr}_s \left[N_{\mathbf{H}} \tilde{H}_u(\tilde{A}_{T/u}^2) \right] \right| \leq c \exp \left(\frac{-C}{u^2} \right).$$

Using (11.24)-(11.27), we get (11.15). The proof of our Theorem is completed. \square

By (11.10), we see that

$$(11.28) \quad \tilde{F}_u(A_{u,T}^2) = \int_{-\infty}^{+\infty} \cos(t\sqrt{2A_{u,T}^2}) \exp \left(\frac{-t^2}{2} \right) f(ut) \frac{dt}{\sqrt{2\pi}}.$$

Also $A_{u,T}^2$ is a second order elliptic operator whose principal symbol is given by $u^2 \frac{|\xi|^2}{2}$.

Let $\tilde{F}_u(A_{u,T}^2)(x, x')$ ($x, x' \in X$) be the smooth kernel of $\tilde{F}_u(A_{u,T}^2)$ with respect to $\frac{dv_X(x')}{(2\pi)^{\dim X}}$. Then

$$(11.29) \quad \text{Tr}_s \left[N_{\mathbf{H}} \tilde{F}_{u,T}(A_{u,T}^2) \right] = \int_X \text{Tr}_s \left[N_{\mathbf{H}} \tilde{F}_u(A_{u,T}^2)(x, x) \right] \frac{dv_X(x)}{(2\pi)^{\dim X}}.$$

Using finite propagation speed [21], [35] and (11.28), we see that if $x \in V$, $\tilde{F}_u(A_{u,T}^2)(x, x')$ vanishes for $x' \notin B^X(x, \alpha)$ and only depends on the restriction of $A_{u,T}^2$ to $B^X(x, \alpha)$.

By Theorem 11.3, we find that the proof of (6.19) has been reduced to a local problem on a given fibre X . A probabilistic proof of this fact can also be given along the lines of [19, Proposition 11.10]. However the argument is slightly more complicated than in [19], because the Lichnerowicz formula in (7.47) is more involved than the formula for one given fibre used in [19].

11.3 A rescaling of the normal coordinate Z_0

Definition 11.4. For $T \geq 0$, let $\beta_T(x)$ be the smooth section of $\pi^* \Lambda(T_{\mathbf{R}}^* S)$ such that

$$(11.30) \quad \beta_T(x) dv_X(x) = \left\{ \text{Td}(TX, g^{TX}) \Phi \text{Tr}_s \left[N_{\mathbf{H}} \exp(-C_{T^2}^2) \right] \right\}_x^{\max}.$$

The key result of this Chapter is the following extension of [19, Theorem 11.13].

Theorem 11.5 — *There exist $\gamma \in]0, 1[$ such that for any $p \in \mathbf{N}$, there is $C_p > 0$ such that if $u \in]0, 1[$, $T \in [1, \frac{1}{u}]$, $y_0 \in W$, $Z_0 \in N_{Y/X, \mathbf{R}, y_0}$, $|Z_0| \leq \frac{\alpha T}{2}$,*

$$(11.31) \quad \frac{1}{T^{2 \dim N_{Y/X}}} \left| \Phi \text{Tr}_s \left[N_{\mathbf{H}} \tilde{F}_u(A_{u,T}^2) \left(\left(y_0, \frac{Z_0}{T} \right), \left(y_0, \frac{Z_0}{T} \right) \right) \right] - \beta_T \left(y_0, \frac{Z_0}{T} \right) \right| \leq C_p (1 + |Z_0|)^{-p} (u(1+T))^\gamma.$$

Remark 11.6. From Theorem 11.5, one derives (6.19) in the same way as in [19, Remark 11.14] using [19, Theorem 11.13]. In particular one has to apply Theorem 11.5 in the case where $Y = \emptyset$. Using also Proposition 11.1, we have thus proved Theorem 6.7.

11.4 A local coordinate system near W and a trivialization of $\pi_V^* \Lambda(T_{\mathbf{R}}^* S) \hat{\otimes} \Lambda(T^{*(0,1)} X) \hat{\otimes} \xi$

Let $\nabla^{\pi_V^* \Lambda(T_{\mathbf{R}}^* S) \hat{\otimes} \Lambda(T^{*(0,1)} X)}$ be the connection on $\pi_V^* \Lambda(T_{\mathbf{R}}^* S) \hat{\otimes} \Lambda(T^{*(0,1)} X)$ along the fibres X , which is induced by $\nabla^{\Lambda(T^{*(0,1)} X)}$.

Let $e_1, \dots, e_{2\ell}$ be an orthonormal basis of $T_{\mathbf{R}} X$. Let f_1, \dots, f_{2m} be a basis of $T_{\mathbf{R}} S$, let f^1, \dots, f^m be the corresponding dual basis of $T_{\mathbf{R}}^* S$.

Definition 11.7. Let ${}^1\nabla\pi_V^*\Lambda(T_{\mathbf{R}}^*S)\widehat{\otimes}\Lambda(T^{*(0,1)}X)$ be the connection on $\pi_V^*\Lambda(T_{\mathbf{R}}^*S)\widehat{\otimes}\Lambda(T^{*(0,1)}X)$ along the fibres X given by

$$(11.32) \quad {}^1\nabla\pi_V^*\Lambda(T_{\mathbf{R}}^*S)\widehat{\otimes}\Lambda(T^{*(0,1)}X) = \nabla\pi_V^*\Lambda(T_{\mathbf{R}}^*S)\widehat{\otimes}\Lambda(T^{*(0,1)}X) + \frac{1}{2}\langle S^V e_i, f_\alpha^{H,V} \rangle \sqrt{2}c(e_i)f^\alpha + \frac{1}{2}\langle S^V f_\alpha^{H,V}, f_\beta^{H,V} \rangle f^\alpha f^\beta.$$

Let ${}^2\nabla\pi_V^*\Lambda(T_{\mathbf{R}}^*S)\widehat{\otimes}\Lambda(T^{*(0,1)}X)$ be the connection on $\pi_V^*\Lambda(T_{\mathbf{R}}^*S)\widehat{\otimes}\Lambda(T^{*(0,1)}X)$ along the fibres X

$$(11.33) \quad {}^2\nabla\pi_V^*\Lambda(T_{\mathbf{R}}^*S)\widehat{\otimes}\Lambda(T^{*(0,1)}X) = e^{-f^\gamma \frac{c}{\sqrt{2}}(f_\gamma^{H,N_{Y/X}})} {}^1\nabla\pi_V^*\Lambda(T_{\mathbf{R}}^*S)\widehat{\otimes}\Lambda(T^{*(0,1)}X) e^{f^\gamma \frac{c}{\sqrt{2}}(f_\gamma^{H,N_{Y/X}})}.$$

Recall that by the results of [4] stated after (1.5),

$$(11.34) \quad \langle S^V f_\alpha^{H,N_{Y/X}}, f_\beta^{H,N_{Y/X}} \rangle = 0.$$

By (7.40), (7.43), (11.34), we get

$$(11.35) \quad {}^2\nabla\pi_V^*\Lambda(T_{\mathbf{R}}^*S)\widehat{\otimes}\Lambda(T^{*(0,1)}X) = \nabla\pi_V^*\Lambda(T_{\mathbf{R}}^*S)\widehat{\otimes}\Lambda(T^{*(0,1)}X) + \frac{1}{2}\left(\langle S^V e_i, f_\alpha^{H,V} \rangle - \langle \nabla^{TX} f_\alpha^{H,N_{Y/X}}, e_i \rangle\right) \sqrt{2}c(e_i)f^\alpha + \frac{1}{2}\left(\langle S^V f_\alpha^{H,W}, f_\beta^{H,W} \rangle - \langle f_\alpha^{H,N_{Y/X}}, \nabla^{TX} f_\beta^{H,N_{Y/X}} \rangle\right) f^\alpha f^\beta.$$

From (11.35), it is clear that if A, B are smooth sections of $T_{\mathbf{R}}X$, then

$$(11.36) \quad {}^2\nabla_A^*\Lambda(T_{\mathbf{R}}^*S)\widehat{\otimes}\Lambda(T^{*(0,1)}X) \frac{c(B)}{\sqrt{2}} = \frac{c(\nabla_A^{TX} B)}{\sqrt{2}} + \left(\langle S^V(A)B, f_\alpha^{H,V} \rangle - \langle \nabla_A^{TX} f_\alpha^{H,N_{Y/X}}, B \rangle\right) f^\alpha.$$

Let $c^1(T_{\mathbf{R}}X) \simeq T_{\mathbf{R}}X$ be the set of elements of length 1 in $c(T_{\mathbf{R}}X)$. It follows from (11.36) that parallel transport along the fibres X with respect to ${}^2\nabla\pi_V^*\Lambda(T_{\mathbf{R}}^*S)\widehat{\otimes}\Lambda(T^{*(0,1)}X)$ maps $c^1(T_{\mathbf{R}}X)$ into $c^1(T_{\mathbf{R}}X) \oplus T_{\mathbf{R}}^*S$, while leaving $\Lambda(T_{\mathbf{R}}^*S)$ invariant.

Let P^{TX} be the projection operator $TV \simeq T^H V \oplus TX \rightarrow TX$.

Proposition 11.8 — *The following identity holds*

$$(11.37) \quad {}^1\nabla\pi_V^*\Lambda(T_{\mathbf{R}}^*S)\widehat{\otimes}\Lambda(T^{*(0,1)}X),2 = \frac{1}{4}\langle (\nabla^{TX})^2 e_i, e_j \rangle c(e_i)c(e_j) + \frac{1}{2}\text{Tr}[(\nabla^{TX})^2] + \frac{1}{2}\langle (S^V P^{TX} S^V + \nabla^{TX} S^V) f_\alpha^{H,V}, f_\beta^{H,V} \rangle f^\alpha f^\beta + \frac{1}{2}\langle \nabla^{TX} S^V e_i, f_\alpha^{H,V} \rangle \sqrt{2}c(e_i)f^\alpha.$$

Also ${}^2\nabla\pi_{\check{\nu}}^*\Lambda(T_{\mathbf{R}}^*S)\widehat{\otimes}\Lambda(T^{*(0,1)}X),2$ is obtained from the expression (11.37) for ${}^1\nabla\pi_{\check{\nu}}^*\Lambda(T_{\mathbf{R}}^*S)\widehat{\otimes}\Lambda(T^{*(0,1)}X),2$ by replacing $c(e_i)$ by $c(e_i) + \sqrt{2} \langle f_{\alpha}^{H,N_{Y/X}}, e_i \rangle f^{\alpha}$.

Proof. If $A \in \text{End}(TX)$, the action of A on $\Lambda(T^{*(0,1)}X)$ is given by

$$(11.38) \quad \frac{1}{4} \langle Ae_i, e_j \rangle c(e_i)c(e_j) + \frac{1}{2} \text{Tr}[A].$$

□

So we find that

$$(11.39) \quad \nabla\Lambda(T^{*(0,1)}X),2 = \frac{1}{4} \langle (\nabla^{TX})^2 e_i, e_j \rangle c(e_i)c(e_j) + \frac{1}{2} \text{Tr} [(\nabla^{TX})^2].$$

Using the identity

$$[c(e_i)f^{\alpha}, c(e_j)f^{\beta}] = 2\delta_{ij}f^{\alpha}f^{\beta},$$

(11.37) follows easily. Using (7.40) and (11.33), one obtains the corresponding formula for $({}^2\nabla\pi_{\check{\nu}}^*\Lambda(T_{\mathbf{R}}^*S)\widehat{\otimes}\Lambda(T^{*(0,1)}X))^2$. □

Recall that for $u > 0$, $\psi_u : \Lambda(T_{\mathbf{R}}^*S) \rightarrow \Lambda(T_{\mathbf{R}}^*S)$ was defined in (9.9).

Definition 11.9. For $u > 0$, let ${}^2\nabla\pi_{\check{\nu}}^*\Lambda(T_{\mathbf{R}}^*S)\widehat{\otimes}\Lambda(T^{*(0,1)}X),u$ be the connection on $\pi_{\check{\nu}}^*\Lambda(T_{\mathbf{R}}^*S) \widehat{\otimes} \Lambda(T^{*(0,1)}X)$ along the fibres X ,

$$(11.40) \quad {}^2\nabla\pi_{\check{\nu}}^*\Lambda(T_{\mathbf{R}}^*S)\widehat{\otimes}\Lambda(T^{*(0,1)}X),u = \psi_u {}^2\nabla\pi_{\check{\nu}}^*\Lambda(T_{\mathbf{R}}^*S)\widehat{\otimes}\Lambda(T^{*(0,1)}X)\psi_u^{-1}.$$

In the sequel, we will use trivializations with respect to the connection ${}^2\nabla\pi_{\check{\nu}}^*\Lambda(T_{\mathbf{R}}^*S)\widehat{\otimes}\Lambda(T^{*(0,1)}X),u$. It will be often more convenient to trivialize with respect to ${}^2\nabla\pi_{\check{\nu}}^*\Lambda(T_{\mathbf{R}}^*S)\widehat{\otimes}\Lambda(T^{*(0,1)}X)$, and to apply afterwards the operator ψ_u .

Take $y_0 \in W$. If $Z \in (T_{\mathbf{R}}X)_{y_0}$, $t \in \mathbf{R} \rightarrow x_t = \exp_{y_0}^X(tZ) \in X_{\pi_{\nu}y_0}$ is the geodesic along the fibre $X_{\pi_{\nu}y_0}$ such that $x_0 = x$, $\frac{dx}{dt}|_{t=0} = Z$. If $|Z| < \varepsilon$, we identify $Z \in (T_{\mathbf{R}}X)_{y_0}$ to $\exp_{y_0}^X(Z) \in X_{\pi_{\nu}y_0}$. Let $B_{y_0}^{TX}(0, \alpha)$ be the open ball in $(T_{\mathbf{R}}X)_{y_0}$ of center 0 and of radius α . The ball $B_{y_0}^{TX}(0, \alpha)$ is then identified to $B^X(y_0, \alpha)$.

Let $dv_{TX}(Z)$ be the volume element in $(T_{\mathbf{R}}X)_{y_0}$. Let $k'(Z)$ be the positive smooth function on $B_{y_0}^{TX}(0, \varepsilon)$ such that

$$(11.41) \quad dv_X(Z) = k'(Z)dv_{TX}(Z).$$

Then $k'(0) = 1$.

We fix $Z_0 \in N_{Y/X,\mathbf{R},y_0}$, $|Z_0| \leq \alpha/2$. Take $Z \in N_{Y/X,\mathbf{R},y_0}$, $|Z| \leq \alpha/2$. The curve $t \in [0, 1] \rightarrow Z_0 + tZ$ lies in $B_{y_0}^{TX}(0, \alpha)$. We identify $(\pi_{\check{\nu}}^*\Lambda(T_{\mathbf{R}}^*S) \widehat{\otimes} \Lambda(T^{*(0,1)}X))_Z$ to $(\pi_{\check{\nu}}^*\Lambda(T_{\mathbf{R}}^*S) \widehat{\otimes} \Lambda(T^{*(0,1)}X))_{Z_0}$ (resp. ξ_Z to ξ_{Z_0}) by parallel transport with respect to the connection ${}^2\nabla\pi_{\check{\nu}}^*\Lambda(T_{\mathbf{R}}^*S)\widehat{\otimes}\Lambda(T^{*(0,1)}X)$ (resp. $\widetilde{\nabla}^{\xi}$) along $t \in [0, 1] \rightarrow Z_0 + tZ$.

When $Z_0 \in N_{Y/X,\mathbf{R},y_0}$, $|Z_0| \leq \alpha/2$ is allowed to vary, we identify $(\pi_{\check{\nu}}^*\Lambda(T_{\mathbf{R}}^*S) \widehat{\otimes} \Lambda(T^{*(0,1)}X))_{Z_0}$ (resp. ξ_{Z_0}) to $(\pi_{\check{\nu}}^*\Lambda(T_{\mathbf{R}}^*S) \widehat{\otimes} \Lambda(T^{*(0,1)}X))_{y_0}$ (resp. ξ_{y_0}) by parallel

transport with respect to $\nabla^{\pi_V^* \Lambda(T_{\mathbf{R}}^* S) \hat{\otimes} \Lambda(T^{*(0,1)} X)}$ (resp. $\tilde{\nabla}^\xi$) along $t \in [0, 1] \rightarrow tZ_0$. Therefore the fibres of $\pi_V^* \Lambda(T_{\mathbf{R}}^* S) \hat{\otimes} \Lambda(T^{*(0,1)} X)$ at $Z_0 + Z$ and y_0 are identified by parallel transport along the broken curve $t \in [0, 1] \rightarrow 2tZ_0, 0 \leq t \leq 1/2, Z_0 + (2t-1)Z, \frac{1}{2} \leq t \leq 1$.

11.5 The Taylor expansion of the operator $\tilde{B}_{u^2}^{V,2}$

Definition 11.10. For $u > 0$, set

$$(11.42) \quad \tilde{B}_{u^2}^V = \exp \left\{ -f^\alpha \frac{c}{\sqrt{2u}} (f_\alpha^{H, N_{Y/X}}) \right\} B_{u^2}^V \exp \left\{ f^\alpha \frac{c}{\sqrt{2u}} (f_\alpha^{H, N_{Y/X}}) \right\}.$$

Then

$$(11.43) \quad \tilde{A}_{u,T} = \tilde{B}_{u^2}^V + TV.$$

Also by Proposition 9.3,

$$(11.44) \quad \tilde{B}_{u^2}^V = u\psi_u \tilde{B}_1^V \psi_u^{-1}.$$

In the sequel, $B_{u^2}^{V,2}, \tilde{A}_{u,T}^2$ are considered as differential operators acting on smooth sections of $(\pi_V^* \Lambda(T_{\mathbf{R}}^* S) \hat{\otimes} (T^{*(0,1)} X) \hat{\otimes} \xi)_{Z_0}$ which depend smoothly on $Z \in (T_{\mathbf{R}} X)_{y_0}, |Z| \leq \alpha/2$.

If $U \in (T_{\mathbf{R}} X)_{y_0}$, let ∇_U be the standard differentiation operator acting on smooth functions on $(T_{\mathbf{R}} X)_{y_0}$. Let $e_1, \dots, e_{2\ell}$ be an orthonormal basis of $(T_{\mathbf{R}} X)_{Z_0}$. For $1 \leq i \leq 2\ell$, let $\tau e_i^{Z_0}(Z)$ be the parallel transport of e_i with respect to ∇^{TX} along the curve $t \in [0, 1] \rightarrow Z_0 + tZ$.

Let Op be the set of scalar differential operators on $B_{y_0}^{TX}(0, \alpha/2)$. It is clear that, in the considered trivializations,

$$\tilde{A}_{u,T}^2, \tilde{B}_{u^2}^{V,2} \in (\pi_W^* \Lambda(T_{\mathbf{R}}^* S) \hat{\otimes} c(T_{\mathbf{R}} X) \hat{\otimes} \text{End}(\xi))_{y_0} \hat{\otimes} \text{Op}.$$

For $p \in \mathbf{N}, q \in \mathbf{N}, \mathcal{O}_q(|Z|^p)$ will denote an expression in $(\pi_W^* \Lambda(T_{\mathbf{R}}^* S) \hat{\otimes} c(T_{\mathbf{R}} X) \hat{\otimes} \text{End}(\xi))_{y_0}$, which has the following two properties:

- For $k \in \mathbf{N}, k \leq p$, its derivatives of order k are $\mathcal{O}(|Z|^{p-k})$ as $|Z| \rightarrow 0$.
- It is of total length $\leq q$ with respect to the obvious \mathbf{Z} -grading of $(\pi_W^* \Lambda(T_{\mathbf{R}}^* S) \hat{\otimes} c(T_{\mathbf{R}} X) \hat{\otimes} \text{End}(\xi))_{y_0}$.

Theorem 11.11 — Take $y_0 \in W, Z_0 \in N_{Y/X, \mathbf{R}, y_0}, |Z_0| \leq \alpha/2$. Then in the given

trivialization of $\pi_V^* \Lambda(T_{\mathbf{R}}^* S) \widehat{\otimes} c(T_{\mathbf{R}} X) \widehat{\otimes} \xi$ near (y_0, Z_0) ,

$$(11.45) \quad \widetilde{B}_{u^2}^{V,2} = -\frac{u^2}{2} \psi_u \sum_1^{2\ell} \left(\nabla_{e_i + \mathcal{O}(|Z|)} + \frac{1}{2} \left({}^2 \nabla \pi_V^* \Lambda(T_{\mathbf{R}}^* S) \widehat{\otimes} \Lambda(T^{*(0,1)} X) \right) \right)_{Z_0}^2 \\ (Z, e_i) + \mathcal{O}_2(|Z|^2) + \mathcal{O}_0(1) \Big)^2 \psi_u^{-1} + u^2 \mathcal{O}_0(1) + \frac{u^2}{4} c(e_i) c(e_j) \\ \left(R_{Z_0}^{\prime \xi}(e_i, e_j) + \mathcal{O}_0(|Z|) \right) + \frac{u^2}{\sqrt{2}} c(e_i) \frac{f^\alpha}{u} \left(R_{Z_0}^{\prime \xi}(e_i, f_\alpha^{H,W}) + \mathcal{O}_0(|Z|) \right) + \frac{1}{2} f^\alpha f^\beta \\ \left(R_{Z_0}^{\prime \xi}(f_\alpha^{H,W}, f_\beta^{H,W}) + \mathcal{O}_0(|Z|) \right) + u^2 \nabla_{\mathcal{O}_0(Z)} + u^2 \psi_u \mathcal{O}_2(|Z|^2) \psi_u^{-1}.$$

Proof. By Proposition 11.8, $\left({}^2 \nabla \pi_V^* \Lambda(T_{\mathbf{R}}^* S) \widehat{\otimes} \Lambda(T^{*(0,1)} X) \right)^2$ is a 2-form on X with values in elements of length ≤ 2 in $\pi_V^* \Lambda(T_{\mathbf{R}}^* S) \widehat{\otimes} c(T_{\mathbf{R}} X)$. Let ${}^2 \Gamma \pi_V^* \Lambda(T_{\mathbf{R}}^* S) \widehat{\otimes} \Lambda(T^{*(0,1)} X)_{, Z_0}$ be the connection form for ${}^2 \nabla \pi_V^* \Lambda(T_{\mathbf{R}}^* S) \widehat{\otimes} \Lambda(T^{*(0,1)} X)$ near Z_0 in the trivialization of $\pi_V^* \Lambda(T_{\mathbf{R}}^* S) \widehat{\otimes} \Lambda(T^{*(0,1)} X)$ with respect to ${}^2 \nabla \pi_V^* \Lambda(T_{\mathbf{R}}^* S) \widehat{\otimes} \Lambda(T^{*(0,1)} X)$. By the considerations we made after (11.36), we find easily that ${}^2 \Gamma \pi_V^* \Lambda(T_{\mathbf{R}}^* S) \widehat{\otimes} \Lambda(T^{*(0,1)} X)$ is a 1-form with values in elements of length ≤ 2 in $(\pi_V^* \Lambda(T_{\mathbf{R}}^* S) \widehat{\otimes} c(T_{\mathbf{R}} X))_{Z_0}$. Using [1, Proposition 3.7], we see that

$$(11.46) \quad {}^2 \Gamma \pi_V^* \Lambda(T_{\mathbf{R}}^* S) \widehat{\otimes} \Lambda(T^{*(0,1)} X)_{, Z_0}(Z) \\ = \frac{1}{2} \left({}^2 \nabla \pi_V^* \Lambda(T_{\mathbf{R}}^* S) \widehat{\otimes} \Lambda(T^{*(0,1)} X) \right)_{Z_0}^2 (Z, \cdot) + \mathcal{O}_2(|Z|^2).$$

Now we use formula (7.47) for $\widetilde{B}_{u^2}^{V,2} = \widetilde{A}_{u,0}^2$ and also (11.46), and we obtain (11.45). \square

Let $\widetilde{F}_u(\widetilde{A}_{u,T}^2)(x, x')$, $(x, x' \in X)$ be the smooth kernel associated to $\widetilde{F}_u(\widetilde{A}_{u,T}^2)$ with respect to $\frac{dv_X(x)}{(2\pi)^{\dim X}}$. Clearly

$$(11.47) \quad \text{Tr} \left[N_{\mathbf{H}} \widetilde{F}_u(A_{u,T}^2)(x, x) \right] = \text{Tr}_s \left[N_{\mathbf{H}} \widetilde{F}_u(\widetilde{A}_{u,T}^2)(x, x) \right].$$

So in Theorem 11.5, we may as well replace $A_{u,T}^2$ by $\widetilde{A}_{u,T}^2$.

Take $y_0 \in W$. For $Z_0 \in N_{Y/X, \mathbf{R}, y_0}$, $|Z_0| \leq \varepsilon/2$, it will be very useful to identify $(\pi^* \Lambda(T_{\mathbf{R}}^* S) \widehat{\otimes} \Lambda(T^{*(0,1)} X) \otimes \xi)_{Z_0}$ to $(\pi^* \Lambda(T_{\mathbf{R}}^* S) \widehat{\otimes} \Lambda(T^{*(0,1)} X) \widehat{\otimes} \xi)_{y_0}$ as indicated in Section 11.4.

11.6 Replacing X by $(T_{\mathbf{R}} X)_{y_0}$

Definition 11.12. Let \mathbf{H}_{y_0} be the vector space of the smooth sections of $(\pi_W^* \Lambda(T_{\mathbf{R}}^* S) \widehat{\otimes} \Lambda(T^{*(0,1)} X) \widehat{\otimes} \xi)_{y_0}$ over $(T_{\mathbf{R}} X)_{y_0}$.

Let Δ^{TX} be the ordinary flat Laplacian of $T_{\mathbf{R}}X$. Then Δ^{TX} acts naturally on \mathbf{H}_{y_0} . Let $\gamma(a)$ be the smooth function of $a \in \mathbf{R}$ considered in (7.29). If $Z \in T_{\mathbf{R}}X$, put

$$(11.48) \quad \rho(Z) = \gamma\left(\frac{|Z|}{4\alpha}\right).$$

Then

$$(11.49) \quad \begin{aligned} \rho(Z) &= 1 && \text{if } |Z| \leq 2\alpha, \\ &= 0 && \text{if } |Z| \geq 4\alpha. \end{aligned}$$

We now fix $Z_0 \in N_{Y/X, \mathbf{R}, y_0}$, $|Z_0| \leq \alpha/2$. As indicated in Section 11.4, the trivialization under consideration of $\pi_V^* \Lambda(T_{\mathbf{R}}^* S) \widehat{\otimes} \Lambda(T^{*(0,1)} X) \widehat{\otimes} \xi$ depends explicitly on Z_0 . Therefore the action of D^X also depends on Z_0 .

Definition 11.13. For $u > 0, T \geq 0$, let $L_{u,T}^{1,Z_0}, M_u^{1,Z_0}$ be the operators acting on \mathbf{H}_{y_0}

$$(11.50) \quad \begin{aligned} L_{u,T}^{1,Z_0} &= (1 - \rho^2(Z)) \left(\frac{-u^2}{2} \Delta^{TX} + T^2 P \xi_{y_0}^+ \right) + \rho^2(Z) \tilde{A}_{u,T}^2(Z_0 + Z), \\ M_u^{1,Z_0} &= -u^2(1 - \rho^2(Z)) \frac{\Delta^{TX}}{2} + \rho^2(Z) \tilde{B}_{u^2}^{V,2}. \end{aligned}$$

Let $\tilde{F}_u(L_{u,T}^{1,Z_0})(Z, Z')$ ($Z, Z' \in (T_{\mathbf{R}}X)_{y_0}$) be the smooth kernel associated to $\tilde{F}_u(L_{u,T}^{1,Z_0})$ with respect to $k'(Z_0) \frac{dv_{TX}(Z')}{(2\pi)^{\dim X}}$. By using finite propagation speed [21, Section 7.8], [35, Section 4.4], we see that for any $y_0 \in W, Z_0 \in N_{Y/X, \mathbf{R}, y_0}, |Z_0| \leq \alpha/2$,

$$(11.51) \quad \tilde{F}_u(\tilde{A}_{u,T}^2)((y_0, Z_0), (y_0, Z_0)) = \tilde{F}_u(L_{u,T}^{1,Z_0})(0, 0).$$

In the next Subsections, we will show that there exist $\gamma \in]0, 1]$, such that for any $p \in \mathbf{N}$, there is $C > 0$ such that if $u \in]0, 1], T \in [1, \frac{1}{u}], y_0 \in W, Z_0 \in N_{Y/X, \mathbf{R}, y_0}, |Z_0| \leq \frac{\alpha T}{2}$,

$$(11.52) \quad \frac{1}{T^{2 \dim N_{Y/X}}} \left| \Phi \operatorname{Tr}_s \left[N_{\mathbf{H}} \tilde{F}_u(L_{u,T}^{1,Z_0/T})(0, 0) \right] - \beta_T(y_0, \frac{Z_0}{T}) \right| \leq \frac{C}{(1 + |Z_0|)^p} (u(1 + T))^\gamma$$

which, by (11.51), is equivalent to (11.31), i.e. establishes Theorem 11.5.

11.7 Rescaling of the variable Z and of the Clifford variables

For $u > 0$, let F_u be the linear map

$$(11.53) \quad h \in \mathbf{H}_{y_0} \rightarrow F_u h \in \mathbf{H}_{y_0} ; F_u h(Z) = h\left(\frac{Z}{u}\right).$$

For $u \geq 0, T > 0$, set

$$(11.54) \quad \begin{aligned} L_{u,T}^{2,Z_0} &= F_u^{-1} L_{u,T}^{1,Z_0} F_u, \\ M_u^{2,Z_0} &= F_u^{-1} M_u^{1,Z_0} F_u. \end{aligned}$$

Then, we see that

$$(11.55) \quad L_{u,T}^{2,Z_0}, M_u^{2,Z_0} \in (\pi_W^* \Lambda(T_{\mathbf{R}}^* S) \hat{\otimes} c(T_{\mathbf{R}} X) \hat{\otimes} \text{End}(\xi))_{y_0}.$$

Let $e_1, \dots, e_{2\ell'}$ be an orthonormal oriented basis of $(T_{\mathbf{R}} Y)_{y_0}$, let $e_{2\ell'+1}, \dots, e_{2\ell}$ be an orthonormal oriented basis of $N_{Y/X, \mathbf{R}, y_0}$. Let $e^1, \dots, e^{2\ell'}$ and $e^{2\ell'+1}, \dots, e^{2\ell}$ denote the corresponding dual basis of $(T_{\mathbf{R}}^* Y)_{y_0}$ and $N_{Y/X, \mathbf{R}, y_0}^*$. Then $e_1, \dots, e_{2\ell}$ and $e^1, \dots, e^{2\ell}$ are orthonormal oriented basis of $(T_{\mathbf{R}} X)_{y_0}$ and $(T_{\mathbf{R}}^* X)_{y_0}$.

Definition 11.14. For $u > 0, T > 0$, set

$$(11.56) \quad \begin{aligned} c_{u,T}(e_j) &= \frac{\sqrt{2}e^j \wedge}{u} - \frac{u}{\sqrt{2}} i_{e_j}, \quad 1 \leq j \leq 2\ell', \\ c_{u,T}(e_j) &= \frac{\sqrt{2}e^j \wedge}{uT} - \frac{uT}{\sqrt{2}} i_{e_j}, \quad 2\ell' + 1 \leq j \leq 2\ell. \end{aligned}$$

Definition 11.15. For $u > 0, T > 0$, let $L_{u,T}^{3,Z_0}, M_{u,T}^{3,Z_0} \in (\pi_W^* \Lambda(T_{\mathbf{R}}^* S) \hat{\otimes} \text{End}(\Lambda(T_{\mathbf{R}}^* X) \hat{\otimes} \xi))_{y_0} \otimes \text{Op}$ be the operators obtained from $L_{u,T}^{2,Z_0}, M_u^{2,Z_0}$ by replacing the Clifford variables $c(e_j)$ by the operators $c_{u,T}(e_j)$ considered in Definition 11.14.

Let $\tilde{F}_u(L_{u,T}^{3,Z_0})(Z, Z')$ be the smooth kernel associated to the operator $\tilde{F}_u(L_{u,T}^{3,Z_0})$, calculated with respect to $k'(Z_0) \frac{dv_{TX}(Z')}{(2\pi)^{\dim X}}$. Then $\tilde{F}_u(L_{u,T}^{3,Z_0})(0, 0)$ can be expanded in the form

$$(11.57) \quad \begin{aligned} \tilde{F}_{u,T}(L_{u,T}^{3,Z_0})(0, 0) &= \sum_{\substack{1 < i_1 < i_2 \dots < i_p \leq 2\ell \\ 1 \leq j_1 < j_2 \dots < j_q \leq 2\ell}} e^{i_1} \wedge \dots \wedge e^{i_p} \wedge i_{e_{j_1}} \dots i_{e_{j_q}} \\ &\quad \hat{\otimes} Q_{i_1 \dots i_p}^{j_1 \dots j_q}, Q_{i_1 \dots i_p}^{j_1 \dots j_q} \in (\pi_W^* \Lambda(T_{\mathbf{R}}^* S) \hat{\otimes} \xi)_{y_0}. \end{aligned}$$

Set

$$(11.58) \quad \left[\tilde{F}_{u,T}(L_{u,T}^{3,Z_0})(0, 0) \right]^{\max} = Q_{1, \dots, 2\ell} \in (\pi_W^* \Lambda(T_{\mathbf{R}}^* S) \hat{\otimes} \text{End}(\Lambda(T_{\mathbf{R}}^* X) \hat{\otimes} \xi))_{y_0},$$

so that (11.58) is the coefficient of $e^1 \wedge \dots \wedge e^{2\ell}$ in (11.57).

Proposition 11.16 — *The following identity holds,*

$$(11.59) \quad \frac{1}{T^{2 \dim N_{Y/X}}} \text{Tr}_s \left[N_{\mathbf{H}} \tilde{F}_u(\tilde{A}_{u,T}^2)((y_0, Z_0), (y_0, Z_0)) \right] = (-i)^{\dim X} \text{Tr}_s \left[N_{\mathbf{H}} \left[\tilde{F}_{u,T}(L_{u,T}^{3,Z_0})(0, 0) \right]^{\max} \right].$$

Proof. Equation (11.59) follows from (11.51) and from [19, Proposition 11.2]. \square

Let $N^{N_{Y/X}}$ be the number operator of $\Lambda(N_{Y/X, \mathbf{R}}^*)$. Then $N^{N_{Y/X}}$ acts naturally on $\Lambda(T_{\mathbf{R}}^*X)|_W$.

Put

$$\dot{e}_i = \tau e_i^0(Z_0), \quad 1 \leq i \leq 2\ell'.$$

Then $\dot{e}_1, \dots, \dot{e}_{2\ell}$ is an orthonormal basis of $(T_{\mathbf{R}}X)_{Z_0}$.

By using Proposition 11.8 and Theorem 11.11, $L_{u,T}^{3,Z_0}$ can be extended by continuity at $u = 0$. More precisely we have the formula

$$\begin{aligned} (11.60) \quad L_{0,T}^{3,Z_0} = & T^{-N^{N_{Y/X}}} \left\{ -\frac{1}{2} \sum_1^{2\ell} \left(\nabla_{\dot{e}_i} + \frac{1}{4} \sum_{1 \leq j, j' \leq 2\ell} \langle \nabla^{TX} \rangle_{Z_0}^2(Z, \dot{e}_i) \dot{e}_j, \dot{e}_{j'} \right) \right. \\ & (e^j + \langle f_\alpha^{H, N_{Y/X}}, \dot{e}_j \rangle f^\alpha) (e^j + \langle f_\beta^{H, N_{Y/X}}, \dot{e}_j \rangle f^\beta) \\ & + \frac{1}{4} \left\langle (S^V P^{TX} S^V + \nabla^{TX} S^V)_{Z_0}(Z, \dot{e}_i) f_\alpha^{H, V}, f_\beta^{H, V} \right\rangle f^\alpha f^\beta \\ & + \frac{1}{2} \langle \nabla^{TX} S^V \rangle_{Z_0}(Z, \dot{e}_i) \dot{e}_j, f_\alpha^{H, V} \rangle (e^j + \langle f_\beta^{H, N_{Y/X}}, e_j \rangle f^\beta) f^\alpha \Big)^2 \\ & + \frac{1}{2} e^i e^j R_{Z_0}'^\xi(\dot{e}_i, \dot{e}_j) + \frac{1}{2} f^\alpha f^\beta R_{Z_0}'^\xi(f_\alpha^{H, W}, f_\beta^{H, W}) \\ & \quad + e^i f^\beta R_{Z_0}'^\xi(\dot{e}_i, f_\beta^{H, W}) \Big\} T^{N^{N_{Y/X}}} \\ & + T \sum_{1 \leq j \leq 2\ell'} e^j \wedge \nabla_{\dot{e}_j}^\xi V(Z_0) + \sum_{2\ell'+1 \leq j \leq 2\ell} e^j \wedge \nabla_{\dot{e}_j}^\xi V(Z_0) \\ & \quad + T f^\alpha \nabla_{f_\alpha^{H, W}}^\xi V(Z_0) + T^2 V^2(Z_0). \end{aligned}$$

By the fundamental identity of [4, Theorem 4.14], [7, Théorème 2.3], if $A, A' \in (T_{\mathbf{R}}X)$, if $B, B' \in T_{\mathbf{R}}V$, then

$$(11.61) \quad \langle (\nabla^{TX})^2(A, A') P^{TX} B, P^{TX} B' \rangle + \langle (S^V P^{TX} S^V)(A, A') B, B' \rangle \\ + \langle (\nabla^{TX} S^V)(A, A') B, B' \rangle = \langle (\nabla^{TX})^2(B, B') A, A' \rangle.$$

From (11.60), (11.61), we deduce that

$$\begin{aligned} (11.62) \quad L_{0,T}^{3,Z_0} = & T^{-N^{N_{Y/X}}} \left\{ -\frac{1}{2} \sum_1^{2\ell} \left(\nabla_{\dot{e}_i} + \frac{1}{4} \sum_{1 \leq j, j' \leq 2\ell} \langle (\nabla^{TX})^2 \rangle_{Z_0}(\dot{e}_j, \dot{e}_{j'}) Z, \dot{e}_i \right) \right. \\ & (e^j + \langle f_\alpha^{H, N_{Y/X}}, \dot{e}_j \rangle f^\alpha) (e^{j'} + \langle f_\beta^{H, N_{Y/X}}, \dot{e}_{j'} \rangle f^\beta) \\ & + \frac{1}{4} \left\langle (\nabla^{TX})^2_{Z_0}(f_\alpha^{H, V}, f_\beta^{H, V}) Z, e_i \right\rangle f^\alpha f^\beta \\ & + \frac{1}{2} \langle (\nabla^{TX})^2_{Z_0}(\dot{e}_j, f_\alpha^{H, V}) Z, \dot{e}_i \rangle (e^j + \langle f_\beta^{H, N_{Y/X}}, \dot{e}_j \rangle f^\beta) f^\alpha \Big)^2 \end{aligned}$$

$$\begin{aligned}
 & + \frac{1}{2} e^i e^j R_{Z_0}^{\xi}(\dot{e}_i, \dot{e}_j) + \frac{1}{2} f^\alpha f^\beta R_{Z_0}^{\xi}(f_\beta^{H,W}, f_\alpha^{H,W}) \\
 & + e^i f^\beta R_{Z_0}^{\xi}(e_i, f_\beta^{H,W}) \} T^{N^{Y/X}} + T \sum_{1 \leq j \leq 2\ell'} e^j \wedge \nabla_{\dot{e}_j}^\xi V(Z_0) \\
 & + \sum_{2\ell'+1 \leq j \leq 2\ell} e^j \wedge \nabla_{\dot{e}_j}^\xi V(Z_0) + T f^\alpha \nabla_{f_\alpha^{H,W}}^\xi V(Z_0) + T^2 V^2(Z_0).
 \end{aligned}$$

Recall that we have the C^∞ splitting

$$(11.63) \quad TV = T^{H,W}V \oplus TX.$$

The splitting (11.63) induces the identification

$$(11.64) \quad \Lambda(T_{\mathbf{R}}^*V) \simeq \pi_V^* \Lambda(T_{\mathbf{R}}^*S) \widehat{\otimes} \Lambda(T_{\mathbf{R}}^*X).$$

Using the identification (11.64), we can rewrite $L_{0,T}^{3,Z_0}$ in the form

$$\begin{aligned}
 (11.65) \quad L_{0,T}^{3,Z_0} = & T^{-N^{Y/X}} \left\{ -\frac{1}{2} \sum_1^{2\ell} (\nabla_{\dot{e}_i} + \right. \\
 & \left. \frac{1}{2} \langle (\nabla^{TX})_{Z_0}^2 Z, \dot{e}_i \rangle \right)^2 + R_{Z_0}^{\xi} + T \nabla^\xi V(Z_0) + T^2 V^2(Z_0) \} T^{N^{Y/X}}.
 \end{aligned}$$

11.8 The matrix structure of $L_{u,T}^{3,Z_0/T}$

By Proposition 11.8, Theorem 11.11 and (11.62), we get an asymptotic expression for $M_{u,T}^{Z_0/T}$ as $u \rightarrow 0$ very similar to [19, eq. (11.59)], which we do not rewrite, because of its sheer length. Note that in [19], the \dot{e}_i were noted e_i .

Observe that

$$\begin{aligned}
 (11.66) \quad L_{u,T}^{1,Z_0} = & M_{u,T}^{1,Z_0} + \rho^2(Z) (T f^\alpha \nabla_{f_\alpha^{H,W}}^\xi V + \\
 & u T c(\tau^{Z_0} \dot{e}_i) \nabla_{\tau^{Z_0} \dot{e}_i}^\xi V + T^2 V^2)(Z_0 + Z) + T^2 (1 - \rho^2(Z)) P_{y_0}^{\xi+}.
 \end{aligned}$$

If $C \in (\pi_V^* \Lambda(T_{\mathbf{R}}^*S) \widehat{\otimes} c(T_{\mathbf{R}}X) \widehat{\otimes} \text{End}(\xi))_{Z_0+Z}$, let $C_{u,T}^{(3)} \in (\pi_W^* \Lambda(T_{\mathbf{R}}^*S) \widehat{\otimes} \text{End}(\Lambda(T_{\mathbf{R}}^*X) \otimes \xi))_{y_0}$ be the operator obtained from C by the trivialization indicated in Section 11.4, and by making the Clifford rescaling indicated in Definition 11.15. By (11.66), we get

$$\begin{aligned}
 (11.67) \quad L_{u,T}^{3,Z_0/T} = & M_{u,T}^{3,Z_0/T} + \rho^2(uZ) \left\{ T f^\alpha \nabla_{f_\alpha^{H,W}}^\xi V + \right. \\
 & \left. u T c(\tau^{Z_0/T} \dot{e}_i) \nabla_{\tau^{Z_0/T} \dot{e}_i}^\xi V + T^2 V^2 \right\}_{u,T}^{(3)} + T^2 (1 - \rho^2(uZ)) P_{y_0}^{\xi+}.
 \end{aligned}$$

Clearly

$$(11.68) \quad \left\{ f^\alpha \nabla_{f_\alpha^{H,W}}^\xi V \left(\frac{Z_0}{T} + uZ \right) \right\}_{\substack{u,T \\ Z_0=0 \\ Z=0}}^{(3)} = f^\alpha \nabla_{f_\alpha^{H,W}}^\xi V(y_0).$$

By Theorem 9.8,

$$(11.69) \quad P^{\xi^-} \nabla_{f_\alpha^{H,W}}^\xi V P_{|W}^{\xi^-} = 0,$$

and so

$$(11.70) \quad P^{\xi^-} \nabla_{f_\alpha^{H,W}}^\xi V \left(\frac{Z_0}{T} + uZ \right) P^{\xi^-} = \mathcal{O} \left(\frac{|Z_0|}{T} + |uZ| \right).$$

Now we expand first $\frac{c}{\sqrt{2}} \left(\tau \dot{e}_i^{Z_0/T} (Z_0/T + uZ) \right)$ as $u \rightarrow 0$ by first using the trivialization associated to the connection ${}^2\nabla^{\pi^* \Lambda(T_{\mathbb{R}}^* S) \otimes \Lambda(T^{*(0,1)} X)}$. By (11.36),

$$(11.71) \quad \frac{c}{\sqrt{2}} \left(\tau^{Z_0/T} \dot{e}_i (Z_0/T + uZ) \right) = \frac{c}{\sqrt{2}} (\dot{e}_i)_{Z_0/T} + u \left(\left\langle S_{Z_0/T}^V(Z) \dot{e}_i, f_\alpha^{H,V} \right\rangle - \left\langle \nabla_Z^{TX} f_\alpha^{H, N_{Y/X}}, \dot{e}_i \right\rangle_{Z_0/T} \right) f^\alpha + \mathcal{O}_1(|uZ|^2).$$

The corresponding expansion of $\frac{c(\tau^{Z_0/T} \dot{e}_i (Z_0/T + uZ))}{\sqrt{2}}$ as $u \rightarrow 0$ with respect to the trivialization induced by ${}^2\nabla^{\pi^* \Lambda(T_{\mathbb{R}}^* S) \otimes \Lambda(T^{*(0,1)} X), u}$ is simply obtained from (11.71) by replacing f^α by $\frac{f_\alpha^x}{u}$. So for $1 \leq i \leq 2\ell'$, we get for $u \in]0, 1]$, $T \in [1, 1/u]$,

$$(11.72) \quad \left\{ uT \frac{c(\tau^{Z_0/T} \dot{e}_i)}{\sqrt{2}} \left(\frac{Z_0}{T} + uZ \right) \right\}_{u,T}^3 = T(e^i \wedge -\frac{u^2}{2} i_{e_i}) + \mathcal{O}(uT|Z|),$$

and for $2\ell' + 1 \leq i \leq 2\ell$,

$$(11.73) \quad \left\{ uT \frac{c(\tau^{Z_0/T} \dot{e}_i)}{\sqrt{2}} \left(\frac{Z_0}{T} + uZ \right) \right\}_{u,T}^3 = e^i \wedge -\frac{u^2 T^2}{2} i_{e_i} + \mathcal{O}(uT|Z|).$$

From (11.72), (11.73), we obtain for $1 \leq i \leq 2\ell'$, $u \in]0, 1]$,

$$(11.74) \quad \left\{ uT \frac{c(\tau^{Z_0/T} \dot{e}_i)}{\sqrt{2}} \nabla_{\tau^{Z_0/T} \dot{e}_i}^\xi V \left(\frac{Z_0}{T} + uZ \right) \right\}_{u,T}^{(3)} = T(e^i \wedge -\frac{u^2}{2} i_{e_i}) \nabla_{\tau^{Z_0/T} \dot{e}_i}^\xi V \left(\frac{Z_0}{T} + uZ \right) + \mathcal{O}(uT|Z|),$$

and for $2\ell' + 1 \leq i \leq 2\ell$,

$$(11.75) \quad \left\{ uT \frac{c(\tau^{Z_0/T} \dot{e}_i)}{\sqrt{2}} \nabla_{\tau^{Z_0/T} \dot{e}_i}^\xi V \left(\frac{Z_0}{T} + uZ \right) \right\}_{u,T}^{(3)} = (e^i \wedge -\frac{u^2 T^2}{2} i_{e_i}) \nabla_{\tau^{Z_0/T} \dot{e}_i}^\xi V \left(\frac{Z_0}{T} + uZ \right) + \mathcal{O}(uT|Z|).$$

Since $V_{|W}^- = 0$, by proceeding as in (9.21), for $1 \leq i \leq 2\ell'$, we get

$$(11.76) \quad P^{\xi^-} \nabla_{e_i}^{\xi} V P_{|W}^{\xi^-} = 0,$$

and so for $1 \leq i \leq 2\ell'$,

$$(11.77) \quad P^{\xi^-} \nabla_{e_i}^{\xi} \left(\frac{Z_0}{T} + uZ \right) P^{\xi^-} = \mathcal{O} \left(\left| \frac{Z_0}{T} \right| + |uZ| \right).$$

11.9 A family of Sobolev spaces with weights

Clearly

$$(11.78) \quad \Lambda(T_{\mathbf{R}}^* X)_{y_0} = \Lambda(T_{\mathbf{R}}^* Y)_{y_0} \widehat{\otimes} \Lambda(N_{Y/X, \mathbf{R}}^*)_{y_0}.$$

For $0 \leq p \leq 2\ell'$, $0 \leq q \leq 2\ell$, set

$$\Lambda^{(p,q)}(T_{\mathbf{R}}^* X) = \Lambda^p(T_{\mathbf{R}}^* Y)_{y_0} \widehat{\otimes} \Lambda^q(N_{Y/X, \mathbf{R}}^*)_{y_0}.$$

The various $\Lambda^{(p,q)}(T_{\mathbf{R}}^* X)_{y_0}$ are mutually orthogonal in $\Lambda(T_{\mathbf{R}}^* X)_{y_0}$.

Let \mathbf{I}_{y_0} (resp. $\mathbf{I}_{y_0}^0$) be the set of smooth (resp. square integrable) sections of $(\pi_W^* \Lambda(T_{\mathbf{R}}^* S) \widehat{\otimes} \Lambda(T_{\mathbf{R}}^* X) \widehat{\otimes} \xi)_{y_0}$. For $p \leq \dim T_{\mathbf{R}} Y$, $q \leq \dim N_{Y/X, \mathbf{R}}$, $r \leq \dim T_{\mathbf{R}} S$, let $\mathbf{I}_{(p,q,r), y_0}$ (resp. $\mathbf{I}_{(p,q,r), y_0}^0$) be the set of smooth (resp. square integrable) sections of $(\pi_W^* \Lambda^r(T_{\mathbf{R}}^* S) \widehat{\otimes} \Lambda^p(T_{\mathbf{R}}^* Y) \widehat{\otimes} \Lambda^q(N_{Y/X, \mathbf{R}}^*) \widehat{\otimes} \xi)_{y_0}$ over $(T_{\mathbf{R}} X)_{y_0}$.

Let g^{TS} be a Hermitian metric on TS . Then all the previously considered vector bundles are equipped with a Hermitian metric. Put $\ell' = \dim TY$, $n = \dim N_{Y/X}$, $s = \dim TS$.

Definition 11.17. For $u \in]0, 1]$, $T \in [1, \frac{1}{u}]$, $y_0 \in W$, $Z_0 \in N_{Y/X, \mathbf{R}, y_0}$, $|Z_0| \leq \frac{\alpha T}{2}$, $s \in \mathbf{I}_{(p,q,r), y_0}$, put

$$(11.79) \quad |s|_{u, T, Z_0, 0}^2 = \int_{(T_{\mathbf{R}} X)_{y_0}} |s|^2 \left(1 + (|Z| + |Z_0|) \rho \left(\frac{uZ}{2} \right) \right)^{2(2\ell' + 2s - p - r)} \left(1 + \frac{|Z|}{T} \rho \left(\frac{uZ}{2} \right) \right)^{2(2n - q)} dv_{TX}(Z).$$

For $\mu \in \mathbf{R}$, let $\mathbf{I}_{y_0}^{\mu}$, $\mathbf{I}_{y_0}^{\pm, \mu}$ be the set of sections of $(\pi_W^* \Lambda(T_{\mathbf{R}}^* S) \widehat{\otimes} \Lambda(T_{\mathbf{R}}^* X) \widehat{\otimes} \xi)_{y_0}$, $(\pi_W^* \Lambda(T_{\mathbf{R}}^* S) \widehat{\otimes} \Lambda(T_{\mathbf{R}}^* X) \widehat{\otimes} \xi^{\pm})_{y_0}$, which lie in the μ^{th} Sobolev space. If $s \in \mathbf{I}_{y_0}^{\mu}$, we write s in the form

$$(11.80) \quad s = s^+ + s^- \quad , \quad s^{\pm} \in \mathbf{I}_{y_0}^{\pm, \mu}.$$

Definition 11.18. If $u \in]0, 1]$, $T \in [1, \frac{1}{u}]$, $y_0 \in W$, $Z_0 \in N_{Y/X, \mathbf{R}, y_0}$, $|Z_0| \leq \frac{\alpha T}{2}$, $s \in I_{y_0}^1$, set

$$(11.81) \quad |s|_{u, T, Z_0, 1}^2 = |s|_{u, T, Z_0, 0}^2 + T^2 |s^+|_{u, T, Z_0, 0}^2 + T^2 \left| \rho(uZ)V^-\left(\frac{Z_0}{T} + uZ\right)s^- \right|^2 + \sum_{i=1}^{2\ell} |\nabla_{e_i} s|_{u, T, Z_0, 0}^2 .$$

11.10 Proof of Theorem 11.5

The Sobolev norms (11.79), (11.81) are the obvious analogues of the corresponding norms in [19, Definitions 11.23 and 11.25]. At least formally, the problem treated here is the obvious analogue of the problem considered in [19], with extra Grassmann variables $f^\alpha \wedge$. However, these Grassmann variables come with no variable i_{f_α} , which, in some sense, makes them easier to deal with.

Also the estimates in (11.68)-(11.77) are the obvious analogue of the corresponding estimates in [19, Section 11 j)]. In particular the estimates (11.70), (11.77) should be compared with [19, eq. (11.66)].

One can then proceed formally as in [19, Section 11] and obtain (11.52). As in [19], the Sobolev norms (11.79), (11.81) play a key role in proving the required estimates. Of course here we deal with the kernel of $\tilde{F}_u(L_{u, T}^{3, Z_0})(x, x')$, while in [19, Section 11], we considered directly the kernel $\exp(-L_{u, T}^{3, Z_0})$. However observe that by (11.10), by proceeding as in [19, eq. (13.23)], for any $m \in \mathbf{N}$,

$$(11.82) \quad \sup_{|\text{Im}(a)| \leq c} |u|^m |F_u(a) - \exp(-a^2)| \leq c \exp\left(\frac{-C}{u^2}\right).$$

It is then very easy to incorporate the estimates (11.82) in the arguments of [19] to obtain (11.52). □

11.11 Proof of Theorem 6.17

The proof of (6.81) is essentially similar to the proof of Proposition 11.1.

To establish (6.82) when $h_{u, T} = \theta_{u, T}$, we use the Lichnerowicz formula for

$$(11.83) \quad A^2_{\sqrt{u}, \sqrt{T}} + 2da \frac{\partial}{\partial u} A''_{\sqrt{u}, \sqrt{T}} + 2d\bar{a} \frac{\partial}{\partial u} A'_{\sqrt{u}, \sqrt{T}} - dad\bar{a} \frac{\partial}{\partial u} (uN_u^V).$$

given in [14, Theorem 2.15], and also in (12.39), together with the arguments given above. Details are left to the reader.

The cas where $h_{u, T} = \pi'_{u, T}$ or $h_{u, T} = \pi''_{u, T}$ is obtained from the above by making da or $d\bar{a}$ equal to 0.

12. The analysis of the kernel of $\tilde{F}_u(A_{u,T/u}^2)$ for $T > 0$ as $u \rightarrow 0$

The purpose of this Chapter is to prove Theorems 6.8 and the first half of Theorem 6.18. This Chapter is the obvious extension of [19, Section 12], where the case where S is a point was treated.

As in [19], to prove Theorem 6.8, we exploit results already established in Chapter 11, and also we establish certain key algebraic identities, which extend corresponding identities of [19, Section 12]. That apparently complicate computations simplify dramatically is related in particular to the fact that we made the “right” construction of $T^H W$ in Chapter 7, and also that we chose the adequate trivialization of the vector bundles. Once this is done, we are able to adapt the analytic framework of [19, Section 12] to prove Theorem 6.8. The proof of the first half of Theorem 6.18 involves the control of the speed of convergence of the considered quantities as $u \rightarrow 0$, for $T \in]0, 1]$. This problem was not considered explicitly in [19]. This is why we have to give a more precise form to the estimates of [19, Section 12].

This Chapter is organized as follows. In Section 12.1, we show that the proof of Theorem 6.8 is local on X . In Section 12.2, we construct a coordinate system near $y_0 \in W$, and also a trivialization of $\pi_V^* \Lambda(T_{\mathbf{R}}^* S) \hat{\otimes} \Lambda(T^{*(0,1)} X) \hat{\otimes} \xi$ near y_0 . In Section 12.3, we replace the fibre X by $(T_{\mathbf{R}} X)_{y_0}$. In Section 12.4, we rescale the coordinate Z in $(T_{\mathbf{R}} X)_{y_0}$ and also the Clifford variables. In Section 12.5, we calculate the asymptotics of the operator $L_{u,T/u}^{3,y_0}$, which was obtained from $A_{u,T/u}^2$ by such a rescaling. As in [19, Section 12 f)], the building blocks of the operator $\mathfrak{B}_{T^2}^2$ of Chapter 5, which is associated to the exact sequence $0 \rightarrow TY \rightarrow TX \rightarrow N_{Y/X} \rightarrow 0$, appear in this process. In Section 12.6, we briefly indicate how to establish Theorem 6.8 along the lines of [19, Section 12]. Finally, in Section 12.7, we establish the first half of Theorem 6.18.

In this Chapter, we use the assumptions and notation of Chapters 3-5, 6-9 and 11.

12.1 Localization of the problem

Clearly

$$(12.1) \quad \text{Tr}_s \left[N_{\mathbf{H}} \exp(-A_{u,T/u}^2) \right] = \text{Tr}_s \left[N_{\mathbf{H}} \tilde{F}_u(A_{u,T/u}^2) \right] + \text{Tr}_s \left[N_{\mathbf{H}} \tilde{G}_u(A_{u,T/u}^2) \right].$$

By Theorem 11.3, there exist $c > 0, C > 0$ such that for $u \in]0, 1], T \geq 0$,

$$(12.2) \quad \left| \text{Tr}_s \left[N_{\mathbf{H}} \tilde{G}_u(A_{u,T/u}^2) \right] \right| \leq c \exp\left(\frac{-C}{u^2}\right).$$

By (12.2), we see that to establish Theorem 6.8, we just need to show that as $u \rightarrow 0$,

$$(12.3) \quad \Phi \text{Tr}_s \left[N_{\mathbf{H}} \tilde{F}_u(A_{u,T}^2) \right] \rightarrow \int_Y \Phi \text{Tr}_s \left[N_{\mathbf{H}} \exp(-\mathfrak{B}_T^2) \right] \text{ch}(\eta, g^\eta).$$

As in Chapter 11, using finite propagation speed, the proof of Theorem 6.8 has been reduced to a local problem on X .

Clearly

$$(12.4) \quad \text{Tr}_s \left[N_{\mathbf{H}} \tilde{F}_u(A_{u,T/u}^2) \right] = \text{Tr}_s \left[N_{\mathbf{H}} \tilde{F}_u(\tilde{A}_{u,T/u}^2) \right].$$

Let $\tilde{F}_u(\tilde{A}_{u,T/u}^2)(x, x')(x, x' \in X)$ be the smooth kernel associated to $\tilde{F}_u(\tilde{A}_{u,T/u}^2)$ with respect to $\frac{dv_X(x')}{(2\pi)^{\dim X}}$. Then

$$(12.5) \quad \text{Tr}_s \left[N_{\mathbf{H}} \tilde{F}_u(\tilde{A}_{u,T/u}^2) \right] = \int_X \text{Tr}_s \left[N_{\mathbf{H}} \tilde{F}_u(\tilde{A}_{u,T/u}^2)(x, x) \right] \frac{dv_X(x)}{(2\pi)^{\dim X}}.$$

12.2 A local coordinate system near $y_0 \in W$ and a trivialization of $\Lambda(T^{*(0,1)}X) \hat{\otimes} \xi$

Take $y_0 \in W$. If $Z \in (T_{\mathbf{R}}X)_{y_0}$, $t \in \mathbf{R} \rightarrow x_t = \exp_{y_0}^X(tZ)$ still denotes the geodesic in X , such that $x_0 = y_0$, $\frac{dx}{dt}|_{t=0} = Z$. If $|Z| < \alpha$, we identify $Z \in (T_{\mathbf{R}}X)_{x_0}$ with $\exp_{y_0}^X(Z) \in X$.

Take $u > 0$. If $|Z| < \alpha$, we identify $(\pi_V^* \Lambda(T_{\mathbf{R}}^*S) \hat{\otimes} \Lambda(T^{*(0,1)}X))_Z, \xi_Z$ to $(\pi_W^* \Lambda(T_{\mathbf{R}}^*S) \hat{\otimes} \Lambda(T^{*(0,1)}X))_{y_0}, \xi_{y_0}$ by parallel transport with respect to the connection ${}^2\nabla \pi^*(\Lambda(T_{\mathbf{R}}^*S) \hat{\otimes} \Lambda(T^{*(0,1)}X))_u, \nabla^\xi$ along the curve $t \in [0, 1] \mapsto tZ$.

If $U \in (T_{\mathbf{R}}X)_{y_0}$, $\tau U(Z) \in (T_{\mathbf{R}}X)_Z$ denotes the parallel transport of U along the curve $t \in [0, 1] \rightarrow tZ$ with respect to ∇^{TX} .

12.3 Replacing the fibre X by $(T_{\mathbf{R}}X)_{y_0}$

Let Δ^{TX} be the ordinary flat Laplacian on $(T_{\mathbf{R}}X)_{y_0}$.

Definition 12.1. For $u > 0$, $T > 0$, $y_0 \in Y$, let $L_{u,T/u}^{1,y_0}$ be the operator acting on \mathbf{H}_{y_0}

$$(12.6) \quad \begin{aligned} L_{u,T/u}^{1,y_0} &= (1 - \rho^2(Z)) \left(-\frac{u^2}{2} \Delta^{TX} + \frac{T^2}{u^2} P^{\xi_{y_0}^+} \right) + \rho^2(Z) \tilde{A}_{u,T/u}^2, \\ M_u^{1,y_0} &= -u^2(1 - \rho^2(Z)) \frac{\Delta^{TX}}{2} + \rho^2(Z) \tilde{B}_{u^2}^{V,2}. \end{aligned}$$

With respect to the notation in (11.50), our $L_{u,T/u}^{1,y_0}$, M_u^{1,y_0} are exactly the operators $L_{u,T/u}^{1,0}$, $M_u^{1,0}$.

Clearly

$$(12.7) \quad \begin{aligned} L_u^{1,y_0} &= M_{u,T/u}^{1,y_0} + \rho^2(Z) \left(\frac{T}{u} f^\alpha \nabla_{f_{H,w}^\xi}^\xi V \right. \\ &\quad \left. + T \frac{c(e_i)}{\sqrt{2}} \nabla_{e_i}^\xi V + \frac{T^2}{u^2} V^2 \right) + \frac{T^2}{u^2} (1 - \rho^2(Z)) P^{\xi_{y_0}^+}. \end{aligned}$$

Let $\tilde{F}_u(L_{u,T/u}^{1,y_0})(Z, Z')$ ($Z, Z' \in (T_{\mathbf{R}}X)_{y_0}$) be the smooth kernel associated to $\tilde{F}_u(L_{u,T/u}^{1,y_0})$ calculated with respect to $\frac{dv_{TX}(Z')}{(2\pi)^{\dim X}}$.

12.4 Rescaling of the variable Z and of the horizontal Clifford variables

For $u > 0$, $T > 0$, set

$$(12.8) \quad \begin{aligned} L_{u,T/u}^{2,y_0} &= F_u^{-1} L_{u,T/u}^{1,y_0} F_u, \\ M_u^{2,y_0} &= F_u^{-1} M_u^{1,y_0} F_u. \end{aligned}$$

As in (11.55),

$$(12.9) \quad L_{u,T/u}^{2,y_0}, M_u^{2,y_0} \in (\pi_W^* \Lambda(T_{\mathbf{R}}^* S) \hat{\otimes} c(T_{\mathbf{R}} X) \hat{\otimes} \text{End } \xi)_{y_0} \otimes \text{Op}.$$

Let $e_1, \dots, e_{2\ell'}$ be an orthonormal oriented basis of $(T_{\mathbf{R}}Y)_{y_0}$, let $e_{2\ell'+1}, \dots, e_{2\ell}$ be an orthonormal oriented basis of $N_{Y/X, \mathbf{R}, y_0}$. Let $e^1, \dots, e^{2\ell'}$, and $e^{2\ell'+1}, \dots, e^{2\ell}$ be the corresponding dual basis of $(T_{\mathbf{R}}^* Y)_{y_0}$ and $(N_{Y/X, \mathbf{R}}^*)_{y_0}$.

Definition 12.2. Let $\mathbf{K}_{y_0}, \mathbf{K}_{y_0}^\pm$ be the sets of smooth sections of $(\pi_W^* \Lambda(T_{\mathbf{R}}^* S) \hat{\otimes} \Lambda(T_{\mathbf{R}}^* Y) \hat{\otimes} \Lambda(\bar{N}_{Y/X}^*) \hat{\otimes} \xi)_{y_0}$, $(\pi_W^* \Lambda(T_{\mathbf{R}}^* S) \hat{\otimes} \Lambda(T_{\mathbf{R}}^* Y) \hat{\otimes} \Lambda(\bar{N}_{Y/X}^*) \hat{\otimes} \xi^\pm)_{y_0}$ over $(T_{\mathbf{R}}X)_{y_0}$.

Then $\mathbf{K}_{y_0} = \mathbf{K}_{y_0}^+ \oplus \mathbf{K}_{y_0}^-$.

Definition 12.3. For $u > 0$, set

$$(12.10) \quad \begin{aligned} c_u(e_i) &= \sqrt{2} \frac{e^i}{u} \wedge -\frac{u}{\sqrt{2}} i_{e_i}, \quad 1 \leq i \leq 2\ell' \\ c_u(e_i) &= c(e_i), \quad 2\ell' + 1 \leq i \leq 2\ell. \end{aligned}$$

For $u > 0$, $T > 0$, let $L_{u,T/u}^{3,y_0}$, $M_u^{3,y_0} \in \text{End}(\overline{\mathbf{K}}_{y_0})$ be the operators obtained from $L_{u,T/u}^{2,y_0}$, M_u^{2,y_0} by replacing the variables $c(e_i)$ by $c_u(e_i)$ for $1 \leq i \leq 2\ell'$, while leaving unchanged the operators $c(e_j)$ ($2\ell' + 1 \leq j \leq 2\ell$). Then

$$L_{u,T/u}^{3,y_0}, M_u^{3,y_0} \in (\pi_W^* \Lambda(T_{\mathbf{R}}^* S) \widehat{\otimes} \text{End}(\Lambda(T_{\mathbf{R}}^* Y)) \widehat{\otimes} c(N_{Y/X, \mathbf{R}}) \widehat{\otimes} \text{End}(\xi))_{y_0} \otimes \text{Op}.$$

Let $\tilde{F}_u(L_{u,T/u}^{3,y_0})(Z, Z')$ ($Z, Z' \in (T_{\mathbf{R}} X)_{y_0}$) be the smooth kernel associated to $\tilde{F}_u(L_{u,T/u}^{3,y_0})$, which is calculated with respect to $\frac{dv_{TX}(Z')}{(2\pi)^{\dim X}}$. Then $\tilde{F}_u(L_{u,T/u}^{3,y_0})(Z, Z)$ can be expanded in the form

$$(12.11) \quad \tilde{F}_u(L_{u,T/u}^{3,y_0})(Z, Z) = \sum_{\substack{1 \leq i_1 < \dots < i_p \leq 2\ell' \\ 1 \leq j_1 < \dots < j_q \leq 2\ell'}} e^{i_1} \wedge \dots \wedge e^{i_p} \wedge i_{e_{j_1}} \dots i_{e_{j_q}} \widehat{\otimes} Q_{i_1 \dots i_p}^{j_1 \dots j_q}(Z, Z), \\ Q_{i_1 \dots i_p}^{j_1 \dots j_q}(Z, Z) \in \left(\pi_W^* \Lambda(T_{\mathbf{R}}^* S) \widehat{\otimes} \text{End}(\Lambda(\overline{N}_{Y/X}^*) \widehat{\otimes} \xi) \right)_{y_0}.$$

Set

$$(12.12) \quad \left[\tilde{F}_u(L_{u,T/u}^{3,y_0})(Z, Z) \right]^{\max} = Q_{1 \dots 2\ell'}(Z, Z) \in \left(\pi_W^* \Lambda(T_{\mathbf{R}}^* S) \widehat{\otimes} \text{End}(\Lambda(\overline{N}_{Y/X}^*) \widehat{\otimes} \xi) \right)_{y_0}.$$

Proposition 12.4 — For any $u > 0$, $T > 0$, $y_0 \in W$, $Z_0 \in N_{Y/X, \mathbf{R}, y_0}$, $|Z_0| < \frac{\alpha}{u}$, the following identity holds

$$(12.13) \quad u^{2 \dim N_{Y/X}} \text{Tr}_s \left[N_{\mathbf{H}} \tilde{F}_u(\tilde{A}_{u,T/u}^2)((y_0, uZ_0), (y_0, uZ_0)) \right] k'(uZ_0) \\ (-i)^{\dim Y} \text{Tr}_s \left[N_{\mathbf{H}} \left[\tilde{F}_u(L_{u,T/u}^{3,y_0})(Z_0, Z_0) \right]^{\max} \right].$$

Proof. Since for $|Z| < 2\alpha$, $\rho(Z) = 1$, using finite propagation speed, we see that if $Z_0 \in N_{y/X, \mathbf{R}, y_0}$, $|Z_0| < \alpha$, then

$$(12.14) \quad \tilde{F}_u(A_{u,T/u}^2)(Z_0, Z_0) k'(Z_0) = \tilde{F}_u(\mathcal{L}_{u,T/u}^{1,y_0})(Z_0, Z_0).$$

Identity (12.13) follows from (12.14) and [19, Proposition 11.2]. \square

12.5 The asymptotics of the operator $L_{u,T/u}^{3,y_0}$ as $u \rightarrow 0$

Definition 12.5. Set

$$(12.15) \quad M_0^{3,y_0} = -\frac{1}{2} \left(\nabla_{e_i} + \frac{1}{2} \langle i^* (\nabla^{TX})_{y_0}^2 Z, e_i \rangle \right)^2 + i^* (\nabla \xi, \cdot)^2 + \frac{1}{2} \text{Tr}[\nabla^{TX, 2}].$$

Then

$$(12.16) \quad M_u^{3,y_0} \in (\Lambda(T_{\mathbf{R}}^* W) \widehat{\otimes} \text{End}(\xi))_{y_0} \otimes \text{Op}.$$

The splitting $TW = T^H W \oplus TY$ induces an identification

$$(12.17) \quad \Lambda(T_{\mathbf{R}}^* W) \simeq \pi_W^* \Lambda(T_{\mathbf{R}}^* S) \widehat{\otimes} \Lambda(T_{\mathbf{R}}^* Y).$$

From (12.16), (12.17), we find that

$$(12.18) \quad M_0^{3,y_0} \in (\pi_W^* \Lambda(T_{\mathbf{R}}^* S) \widehat{\otimes} \Lambda(T_{\mathbf{R}}^* Y) \widehat{\otimes} c(N_{Y/X,\mathbf{R}}) \widehat{\otimes} \text{End}(\xi))_{y_0} \otimes \text{Op}.$$

Of course the contribution of $c(N_{Y/X,\mathbf{R}})$ to M_0^{3,y_0} is trivial.

Then we have the obvious extension of [19, Theorem 12.10].

Theorem 12.6 — As $u \rightarrow 0$,

$$(12.19) \quad M_u^{3,y_0} \rightarrow M_0^{3,y_0}.$$

Proof. We proceed as in the proof of (11.60)-(11.65). The main difference is that because the Clifford variables $c(e_i)$ ($2\ell' + 1 \leq i \leq 2\ell$) are not rescaled, they ultimately disappear in the limit. As in (11.62), to calculate the limit M_0^{3,y_0} explicitly, we still use the identity (11.61). The proof of our Theorem is completed. \square

In what follows, we will calculate the expansion as $u \rightarrow 0$ of the remaining terms in $L_{u,T/u}^{3,y_0}$.

If C is a smooth section of $\pi_V^* \Lambda(T_{\mathbf{R}}^* S) \widehat{\otimes} c(T_{\mathbf{R}} X) \widehat{\otimes} \text{End}(\xi)$, if $x \in X_{\pi_W y_0}$ is close to y_0 , we denote by $C_u^3(x)$ the element of $(\pi_W^* \Lambda(T_{\mathbf{R}}^* S) \widehat{\otimes} \text{End}(\Lambda(T_{\mathbf{R}}^* Y)) \widehat{\otimes} c(N_{Y/X,\mathbf{R}}) \widehat{\otimes} \text{End}(\xi))_{y_0}$ which is obtained by using the trivialization of $\pi_V^* \Lambda(T_{\mathbf{R}}^* S) \widehat{\otimes} c(T_{\mathbf{R}} X) \widehat{\otimes} \xi$ associated to ${}^2\nabla^{\pi_V^* \Lambda(T_{\mathbf{R}}^* S) \widehat{\otimes} \Lambda(T^{*(0,1)} X),u}$ and $\widetilde{\nabla}^\xi$ as in Section 12.2, and by applying the transformation on the elements of $c(T_{\mathbf{R}} X)_{y_0}$ of Definition 12.3. In the sequel, we still use the identification (12.17).

Let $S \in \text{End}(\Lambda(\overline{N}^*) \widehat{\otimes} \Lambda(N^*))$ be given by

$$(12.20) \quad S = \frac{\sqrt{-1}}{2} \sum_{2\ell'+1}^{2\ell} c(e_i) \widetilde{c}(e_i).$$

Then S extends to an operator acting on $\Lambda(T_{\mathbf{R}}^* Y) \widehat{\otimes} \Lambda(\overline{N}_{Y/X}^*) \widehat{\otimes} \Lambda(N_{Y/X}^*) \widehat{\otimes} \eta$. Also by (7.17), $\xi_{|W}^- = \Lambda N_{Y/X}^* \otimes \eta$. Therefore S acts on $\Lambda(T_{\mathbf{R}}^* Y) \otimes \Lambda(\overline{N}_{Y/X}^*) \otimes \xi_{|W}^-$.

We use the notation of Section 5.1. In particular $c(AP^{TY} Z)$, $\widetilde{c}(AP^{TY} Z) \in \Lambda(T_{\mathbf{R}}^* W) \widehat{\otimes} \text{End}(\Lambda(\overline{N}_{Y/X}^*) \widehat{\otimes} \Lambda(N_{Y/X}^*))$ are defined as in Definition 5.5.

Now we extend [19, Theorem 12.12].

Theorem 12.7 — As $u \rightarrow 0$,

(12.21)

$$\left\{ \frac{1}{u} f^\alpha \nabla_{f_\alpha^{H,w}}^\xi V(uZ) + \sum_1^{2\ell} \frac{c(\tau e_i)}{\sqrt{2}} \nabla_{\tau e_i}^\xi V(uZ) \right\}_u^3 = \frac{1}{u} i^* \nabla^\xi V + f^\alpha \wedge \left(\tilde{\nabla}_Z^\xi \nabla_{f_\alpha^{H,w}}^\xi V - \nabla_{\nabla_{PT^X Z}^{TX} f_\alpha^{H,N_{Y/X} + TV}(f_\alpha^{H,V}, PT^Y Z)}^\xi V \right)(y_0) + \sum_{i=1}^{2\ell'} e^i \wedge \tilde{\nabla}_Z^\xi \nabla_{\tau e_i}^\xi V(y_0) + \sum_{2\ell'+1}^{2\ell} \frac{c(e_i)}{\sqrt{2}} \nabla_{e_i}^\xi V(y_0) + \mathcal{O}(u(1 + |Z|^2)),$$

$$\frac{1}{u^2} (V^+(uZ))^2 = \frac{1}{u^2} (V^+)^2(y_0) + \frac{1}{u^2} \mathcal{O}(|uZ|),$$

$$\frac{1}{u^2} (V^-(uZ))^2 = \left(\tilde{\nabla}_Z^\xi V^-(y_0) + \mathcal{O}(u|Z|^2) \right)^2.$$

Moreover the following identities hold

$$\begin{aligned} P^{\xi^-} i^* \nabla^\xi V P^{\xi^-} &= 0, \\ P^{\xi^-} (f^\alpha \wedge \left(\tilde{\nabla}_Z^\xi \nabla_{f_\alpha^{H,w}}^\xi V - \nabla_{\nabla_{PT^X Z}^{TX} f_\alpha^{H,N_{Y/X} + TV}(f_\alpha^{H,V}, PT^Y Z)}^\xi V + \sum_{i=1}^{2\ell'} e^i \wedge \tilde{\nabla}_Z^\xi \nabla_{\tau e_i}^\xi V \right)(y_0) P^{\xi^-} &= \frac{\sqrt{-1}}{\sqrt{2}} P^{\xi^-} \hat{c}(AP^{TY} Z) P^{\xi^-}, \\ P^{\xi^-} \left(\sum_{i=2\ell'+1}^{2\ell} \frac{c(e_i)}{\sqrt{2}} \nabla_{e_i}^\xi V \right)(y_0) P^{\xi^-} &= P^{\xi^-} S_{y_0} P^{\xi^-}, \\ (\tilde{\nabla}_Z^\xi V^-)^2(y_0) &= \frac{|P^{N_{Y/X}} Z|^2}{2}, \\ i^* (\tilde{\nabla}^{\xi^-})^2 &= i^* \left(P^{\xi^-} (\nabla^\xi)^2 P^{\xi^-} - P^{\xi^-} \nabla^\xi V P^{\xi^+} [(V^+)^2]^{-1} P^{\xi^+} \nabla^\xi V P^{\xi^-} \right). \end{aligned}$$

Proof. Clearly

$$(12.23) \quad \frac{1}{u} f^\alpha \nabla_{f_\alpha^{H,w}}^\xi V(uZ) = \frac{1}{u} f^\alpha \nabla_{f_\alpha^{H,w}}^\xi V(y_0) + f^\alpha \tilde{\nabla}_Z^\xi \nabla_{f_\alpha^{H,w}}^\xi V(y_0) + \mathcal{O}(u|Z|^2).$$

Also, by using (11.71) at $Z_0 = 0$, we get, in the trivialization induced by

$2\nabla\pi_{\nabla}^*\Lambda(T_{\mathbf{R}}^*S)\widehat{\otimes}\Lambda(T^{*(0,1)}X)$ and $\widetilde{\nabla}\xi$,

$$(12.24) \quad \frac{c(\tau e_i)}{\sqrt{2}}\nabla_{\tau e_i}^{\xi}V(uZ) = \frac{c(e_i)}{\sqrt{2}} + u \left(\langle S_{y_0}^V(Z)e_i, f_{\alpha}^{H,V} \rangle - \langle \nabla_Z^{TX} f_{\alpha,y_0}^{H,N_{Y/X}}, e_i \rangle \right) f^{\alpha} + \mathcal{O}_1(|uZ|^2)(\nabla_{e_i}^{\xi}V(y_0) + u\widetilde{\nabla}_Z^{\xi}\nabla_{\tau e_i}^{\xi}V(y_0) + \mathcal{O}_0(|uZ|^2)).$$

To calculate the corresponding $\left\{ \frac{c(\tau e_i)}{\sqrt{2}}\nabla_{\tau e_i}^{\xi}V(uZ) \right\}_u^3$, we replace in the right-hand side of (12.24) f^{α} by $\frac{f^{\alpha}}{u}$ and $c(e_i)$ by $c_u(e_i)$. We get

$$(12.25) \quad \left\{ \frac{c(\tau e_i)}{\sqrt{2}}\nabla_{\tau e_i}^{\xi}V(uZ) \right\}_u^3 = \frac{1}{u} \sum_{1 \leq i \leq 2\ell'} (e^i \wedge -\frac{u^2}{2}i_{e_i})\nabla_{e_i}^{\xi}V(y_0) + \sum_{2\ell'+1 \leq i \leq 2\ell} \frac{c(e_i)}{\sqrt{2}}\nabla_{e_i}^{\xi}V(y_0) + f^{\alpha} \left(\langle S_{y_0}^V(Z)e_i, f_{\alpha}^{H,V} \rangle - \langle \nabla_Z^{TX} f_{\alpha,y_0}^{H,N_{Y/X}}, e_i \rangle \right) \nabla_{e_i}^{\xi}V(y_0) + \sum_{1 \leq i \leq 2\ell'} (e^i - \frac{u^2}{2}i_{e_i})\widetilde{\nabla}_Z^{\xi}\nabla_{\tau e_i}^{\xi}V(y_0) + \mathcal{O}(u|Z|^2).$$

By (1.5),

$$(12.26) \quad \begin{aligned} \langle S^V(Z)e_i, f_{\alpha}^{H,V} \rangle &= -\langle S^V(Z)f_{\alpha}^{H,V}, e_i \rangle \\ &= -\langle T^V(f_{\alpha}^{H,V}, Z), e_i \rangle. \end{aligned}$$

Using (7.27) and (12.26), we get

$$(12.27) \quad \left(\langle S_{y_0}^V(Z)e_i, f_{\alpha}^{H,V} \rangle - \langle \nabla_Z^{TX} f_{\alpha,y_0}^{H,N_{Y/X}}, e_i \rangle_{y_0} \right) \nabla_{e_i}^{\xi}V(y_0) = -\nabla_{\frac{\nabla_Z^{TX} f_{\alpha}^{H,N_{Y/X}} + T^V(f_{\alpha}^{H,V}, Z)}{P^{TY}Z}}^{\xi}V(y_0) = -\nabla_{\frac{\nabla_Z^{TX} f_{\alpha}^{H,N_{Y/X}} + T^V(f_{\alpha}^{H,V}, P^{TY}Z)}{P^{TY}Z}}^{\xi}V(y_0).$$

By (12.25), (12.27), we obtain

$$(12.28) \quad \left\{ \frac{c(\tau e_i)}{\sqrt{2}}\nabla_{\tau e_i}^{\xi}V(uZ) \right\}_u^3 = \frac{1}{u} \sum_{1 \leq i \leq 2\ell'} e^i \wedge \nabla_{e_i}^{\xi}V(y_0) - f^{\alpha} \nabla_{\frac{\nabla_Z^{TX} f_{\alpha}^{H,N_{Y/X}} + T^V(f_{\alpha}^{H,V}, P^{TY}Z)}{P^{TY}Z}}^{\xi}V(y_0) + \sum_{1 \leq i \leq 2\ell'} e^i \wedge \widetilde{\nabla}_Z^{\xi}\nabla_{\tau e_i}^{\xi}V(y_0) + \sum_{2\ell'+1 \leq i \leq 2\ell} \frac{c(e_i)}{\sqrt{2}}\nabla_{e_i}^{\xi}V(y_0) + \mathcal{O}(u(1+|Z|^2)).$$

Finally

$$(12.29) \quad i^* \nabla^\xi V(y_0) = \sum_{1 \leq i \leq 2\ell'} e^i \wedge \nabla_{e_i}^\xi V(y_0) + f^\alpha \nabla_{f_\alpha^{H,W}}^\xi V(y_0).$$

By (12.23), (12.28), (12.29), we obtain the first identity in (12.21). The second and third identities in (12.21) are trivial and were already obtained in [19, Theorem 12.12] by Taylor expansion.

By proceeding as in (9.21), we get the first identity in (12.22). By Theorem 9.8, $P^{\xi^-} \nabla_{f_\alpha^{H,W}}^\xi V P^{\xi^-} = 0$ on W , and so

$$(12.30) \quad P^{\xi^-} \tilde{\nabla}_{P^{TY} Z}^\xi \nabla_{f_\alpha^{H,W}}^\xi V(y_0) P^{\xi^-} = 0.$$

Also by Theorem 9.8,

$$(12.31) \quad P^{\xi^-} \tilde{\nabla}_{P^{NY/X} Z}^\xi \nabla_{f_\alpha^{H,W}}^\xi V(y_0) P^{\xi^-} = 0.$$

From (12.30), (12.31), we get

$$(12.32) \quad P^{\xi^-} \tilde{\nabla}_Z^\xi \nabla_{f_\alpha^{H,W}}^\xi V(y_0) P^{\xi^-} = 0.$$

Using Theorem 1.10 and Proposition 7.8, we find that

$$(12.33) \quad \begin{aligned} P^{\xi^-} \nabla_{\nabla_{P^{TY} Z}^{TX} f_\alpha^{H,NY/X} + T^V(f_\alpha^{H,V}, P^{TY} Z)}^\xi V P^{\xi^-} \\ = \frac{\sqrt{-1}}{\sqrt{2}} \hat{c} \left(P^{NY/X} (\nabla_{P^{TY} Z}^{TX} f_\alpha^{H,NY/X} + T^V(f_\alpha^{H,V}, P^{TY} Z)) \right) \\ = P^{\xi^-} \frac{\sqrt{-1}}{\sqrt{2}} \hat{c} (A(f_\alpha^{H,W}) P^{TY} Z) P^{\xi^-}. \end{aligned}$$

From (12.33), we obtain

$$(12.34) \quad \begin{aligned} P^{\xi^-} \left(-f^\alpha \wedge \nabla_{\nabla_{P^{TY} Z}^{TX} f_\alpha^{H,NY/X} + T^V(f_\alpha^{H,V}, P^{TY} Z)}^\xi V \right) P^{\xi^-} \\ = P^{\xi^-} \frac{\sqrt{-1}}{\sqrt{2}} \hat{c} (f^\alpha A(f_\alpha^{H,W}) P^{TY} Z) P^{\xi^-}. \end{aligned}$$

Also by [19, Theorem 12.12],

$$(12.35) \quad P^{\xi^-} \sum_{i=1}^{2\ell'} e^i \wedge \tilde{\nabla}_Z^\xi \nabla_{\tau e_i}^\xi V(y_0) = P^{\xi^-} \frac{\sqrt{-1}}{\sqrt{2}} \hat{c} \left(\sum_{i=1}^{2\ell'} e^i \wedge A(e_i) P^{TY} Z \right).$$

From (12.34), (12.35), we get the second identity in (12.22). The last three identities in (12.22) were already proved in [19, Theorem 12.12]. The proof of our Theorem is completed. \square

12.6 Proof of Theorem 6.8

Recall that we reduced the proof of Theorem 6.8 to the proof of (12.3).

We claim that using Theorems 12.6 and 12.7, the proof of (12.3) is essentially identical to the proof of [19, Theorem 6.7] given in [19, Section 12]. In effect, by using the arguments of Chapter 11, the obvious analogue of [19, Theorem 12.14] holds. Namely, we obtain uniform estimates on the kernel $\tilde{F}_u(L_{u,T/u}^{3,y_0})(Z, Z')$ and its derivatives. Also using Theorem 12.6 and Theorem 12.7, the same arguments as in [19] show that the analogue of [19, Theorem 12.16] holds. Namely put

$$(12.36) \quad U = \{ \lambda \in \mathbf{C}, \operatorname{Re}(\lambda) \leq \delta \operatorname{Im}^2(\lambda) - A \}.$$

Then the analogue of [19, Theorem 12.16] asserts that if A is large enough, and if δ is small enough, for $T > 0$, $y_0 \in W$, $\lambda \in U$, as $u \rightarrow 0$,

$$(12.37) \quad (\lambda - L_{u,T/u}^{3,y_0})^{-1} \rightarrow P^{\xi_{y_0}} \left(\lambda - \mathfrak{B}_{T^2}^{2,y_0} - (\nabla^\eta)_{y_0}^2 \right)^{-1} P^{\xi_{y_0}} \text{ in the sense of distributions.}$$

Note that the operator $\mathfrak{B}_{T^2}^{2,y_0}$ appears in (12.37) because of Theorem 12.6 and of the algebraic identities of Theorem 12.7.

The proof of (12.3) then continues as in [19, Section 12 i)]. □

12.7 Proof of the first half of Theorem 6.18

To establish the first half of Theorem 6.18, we will first show how to prove that if $h_{u,T}$ is any of the functions $\theta_{u,T}$, $\lambda'_{u,T}$, $\lambda''_{u,T}$, $\pi'_{u,T}$, $\pi''_{u,T}$, for $T > 0$,

$$(12.38) \quad \lim_{u \rightarrow 0} h_{u,T/u} = h_T.$$

Then we will explain how to obtain the estimate (6.83).

Clearly, the most complex expression is $\theta_{u,T}$, the others expressions being obtained from $\theta_{u,T}$ by making da or $d\bar{a} = 0$, so in our proof of (12.38), we just consider the case where $h_{u,T} = \theta_{u,T}$.

If $A \in T_{\mathbf{R}}X$, let $A^{(1,0)}$, $A^{(0,1)}$ be the component of A in TX, \overline{TX} . By [14, Theorem 2.15] (and keeping in mind that $\frac{\partial}{\partial u} N_u^V = N_V^X$), we have the following extension of

Theorem 7.19,

$$\begin{aligned}
 (12.39) \quad & A_{u,T}^2 + dau \frac{\partial}{\partial u} A''_{u,T} + d\bar{a}u \frac{\partial}{\partial u} A'_{u,T} - dad\bar{a}N_{\mathbf{V}}^X = \\
 & - \frac{u^2}{2} \left(\nabla_{e_i}^{\Lambda(T^{*(0,1)}X)} \widehat{\otimes} \xi + \frac{1}{2} \langle S^V(e_i)e_j, f_{\alpha}^{H,V} \rangle \right. \\
 & \left. + \sqrt{2}c(e_j) \frac{f_{\alpha}^{\beta}}{u} + \frac{1}{2} \langle S^V(e_i)f_{\alpha}^{H,V}, f_{\beta}^{H,V} \rangle \frac{f_{\alpha}^{\beta} f_{\beta}^{\alpha}}{u^2} \right. \\
 & \left. + \frac{c(e_i^{(0,1)})}{\sqrt{2}} \frac{da}{u} + \frac{c(e_i^{(0,1)})}{\sqrt{2}} \frac{d\bar{a}}{u} \right)^2 + \frac{u^2 K}{8} \\
 & + \frac{u^2}{4} c(e_i)c(e_j)R'^{\xi}(e_i, e_j) + u \frac{c(e_i)f_{\alpha}^{\beta}}{\sqrt{2}} R'^{\xi}(e_i, f_{\alpha}^{H,V}) \\
 & + \frac{1}{2} f_{\alpha}^{\beta} f_{\beta}^{\alpha} R'^{\xi}(f_{\alpha}^{H,V}, f_{\beta}^{H,V}) + uT \frac{c(e_i)}{\sqrt{2}} \nabla_{e_i}^{\xi} V \\
 & + Tf_{\alpha}^{\beta} \nabla_{f_{\alpha}^{H,V}}^{\xi} V + T^2 V^2 - dad\bar{a} \frac{\dim X}{2}.
 \end{aligned}$$

Let $c_{\cdot}^{(1,0)}, c_{\cdot}^{(0,1)} \in T_{\mathbf{R}}^*X \widehat{\otimes} \text{End}(\Lambda(T^{*(0,1)}X))$ be given by $X \in T_{\mathbf{R}}X \rightarrow c(X^{(1,0)})$, $c(X^{(0,1)}) \in \text{End}(\Lambda(T^{*(0,1)}X))$.

Now we define the fibrewise connection on $\pi_{\mathbf{V}}^* \Lambda(T_{\mathbf{R}}^*S) \widehat{\otimes} \Lambda(\mathbf{R}^{2*}) \widehat{\otimes} \Lambda(T^{*(0,1)}X)$,

$$\begin{aligned}
 (12.40) \quad & {}^1\nabla_{\pi_{\mathbf{V}}^* \Lambda(T_{\mathbf{R}}^*S) \widehat{\otimes} \Lambda(\mathbf{R}^{2*}) \widehat{\otimes} \Lambda(T^{*(0,1)}X)} = \\
 & {}^1\nabla_{\pi_{\mathbf{V}}^* \Lambda(T_{\mathbf{R}}^*S) \widehat{\otimes} \Lambda(T^{*(0,1)}X)} + \frac{c_{\cdot}^{(1,0)}}{\sqrt{2}} da + \frac{c_{\cdot}^{(0,1)}}{\sqrt{2}} d\bar{a}.
 \end{aligned}$$

By comparing (7.47) and (12.39), it is clear that in the analysis of $\theta_{u,T/u}$, ${}^1\nabla_{\pi_{\mathbf{V}}^* \Lambda(T_{\mathbf{R}}^*S) \widehat{\otimes} \Lambda(T^{*(0,1)}X)}$ is replaced by ${}^1\nabla_{\pi_{\mathbf{V}}^* \Lambda(T_{\mathbf{R}}^*S) \widehat{\otimes} \Lambda(\mathbf{R}^{2*}) \widehat{\otimes} \Lambda(T^{*(0,1)}X)}$. Let w_1, \dots, w_ℓ be an orthonormal basis of TX , let w^1, \dots, w^ℓ be the dual basis of T^*X . In particular

$$\begin{aligned}
 (12.41) \quad & c_{\cdot}^{(1,0)} = w^i c(w_i), \\
 & c_{\cdot}^{(0,1)} = \bar{w}^i c(\bar{w}_i).
 \end{aligned}$$

A trivial computation shows that

$$\begin{aligned}
 (12.42) \quad & {}^1\nabla_{\pi_{\mathbf{V}}^* \Lambda(T_{\mathbf{R}}^*S) \widehat{\otimes} \Lambda(\mathbf{R}^{2*}) \widehat{\otimes} \Lambda(T^{*(0,1)}X), 2} = \\
 & {}^1\nabla_{\pi_{\mathbf{V}}^* \Lambda(T_{\mathbf{R}}^*S) \widehat{\otimes} \Lambda(T^{*(0,1)}X), 2} + e^i \left(w^k f_{\alpha}^{\beta} da \langle S(e_i)w_k, f_{\alpha}^{H,V} \rangle + \right. \\
 & \left. \bar{w}^k f_{\alpha}^{\beta} d\bar{a} \langle S(e_i)\bar{w}_k, f_{\alpha}^{H,V} \rangle \right) + w^i \bar{w}^i dad\bar{a}.
 \end{aligned}$$

By (2.8) and (12.42), we obtain

$$\begin{aligned}
 (12.43) \quad & {}^1\nabla_{\pi_{\mathbf{V}}^* \Lambda(T_{\mathbf{R}}^*S) \widehat{\otimes} \Lambda(\mathbf{R}^{2*}) \widehat{\otimes} \Lambda(T^{*(0,1)}X), 2} = \\
 & {}^1\nabla_{\pi_{\mathbf{V}}^* \Lambda(T_{\mathbf{R}}^*S) \widehat{\otimes} \Lambda(T^{*(0,1)}X), 2} \\
 & + w^i w^k f_{\alpha}^{\beta} da \langle S(w_i)w_k, f_{\alpha}^{H,V} \rangle + \bar{w}^i \bar{w}^k f_{\alpha}^{\beta} d\bar{a} \langle S(\bar{w}_i)\bar{w}_k, f_{\alpha}^{H,V} \rangle + w^i \bar{w}^i dad\bar{a}.
 \end{aligned}$$

By (1.5) and by Theorem 2.3, which asserts that T^V is of complex type $(1, 1)$, we obtain from (12.43),

$$(12.44) \quad {}^1\nabla\pi_{\check{V}}^*\Lambda(T_{\mathbf{R}}^*S)\widehat{\otimes}\Lambda(\mathbf{R}^{2*})\widehat{\otimes}\Lambda(T^{*(0,1)}X),2 = \\ {}^1\nabla\pi_{\check{V}}^*\Lambda(T_{\mathbf{R}}^*S)\widehat{\otimes}\Lambda(T^{*(0,1)}X),2 + w^i \wedge \bar{w}^i dad\bar{a}.$$

We define ${}^2\nabla\pi_{\check{V}}^*\Lambda(T_{\mathbf{R}}^*S)\widehat{\otimes}\Lambda(\mathbf{R}^{2*})\widehat{\otimes}\Lambda(T^{*(0,1)}X)$ from ${}^1\nabla\pi_{\check{V}}^*\Lambda(T_{\mathbf{R}}^*S)\widehat{\otimes}\Lambda(\mathbf{R}^{2*})\widehat{\otimes}\Lambda(T^{*(0,1)}X)$ as in (11.33). By (7.40),

$$(12.45) \quad {}^2\nabla\pi_{\check{V}}^*\Lambda(T_{\mathbf{R}}^*S)\widehat{\otimes}\Lambda(\mathbf{R}^{2*})\widehat{\otimes}\Lambda(T^{*(0,1)}X) = {}^2\nabla\pi_{\check{V}}^*\Lambda(T_{\mathbf{R}}^*S)\widehat{\otimes}\Lambda(T^{*(0,1)}X) \\ + \frac{1}{\sqrt{2}}(c(\cdot(1,0)) + \sqrt{2}\langle f_{\alpha}^{H,N_{Y/X}}, \cdot(1,0) \rangle) f^{\alpha} da \\ + \frac{1}{\sqrt{2}}(c(\cdot(0,1)) + \sqrt{2}\langle f_{\alpha}^{H,N_{Y/X}}, \cdot(0,1) \rangle) f^{\alpha} d\bar{a}.$$

By (12.44),

$$(12.46) \quad {}^2\nabla\pi_{\check{V}}^*\Lambda(T_{\mathbf{R}}^*S)\widehat{\otimes}\Lambda(\mathbf{R}^{2*})\widehat{\otimes}\Lambda(T^{*(0,1)}X),2 = \\ {}^2\nabla\pi_{\check{V}}^*\Lambda(T_{\mathbf{R}}^*S)\widehat{\otimes}\Lambda(T^{*(0,1)}X),2 + w^i\bar{w}^i dad\bar{a}.$$

To establish (12.38), we proceed exactly as in Sections 12.1-12.6, by replacing $\Lambda(T_{\mathbf{R}}^*S)$ by $\Lambda(T_{\mathbf{R}}^*S) \widehat{\otimes} \Lambda(\mathbf{R}^2)$ and ${}^2\nabla\pi_{\check{V}}^*\Lambda(T_{\mathbf{R}}^*S)\widehat{\otimes}\Lambda(T^{*(0,1)}X)$ by ${}^2\nabla\pi_{\check{V}}^*\Lambda(T_{\mathbf{R}}^*S)\widehat{\otimes}\Lambda(\mathbf{R}^{2*})\widehat{\otimes}\Lambda(T^{*(0,1)}X)$. In particular, trivializations are now done with respect to the connection ${}^2\nabla\pi_{\check{V}}^*\Lambda(T_{\mathbf{R}}^*S)\widehat{\otimes}\Lambda(\mathbf{R}^{2*})\widehat{\otimes}\Lambda(T^{*(0,1)}X),u$.

In view of (12.46), the operator M_0^{3,y_0} in (12.15) should now be

$$(12.47) \quad M_0^{3,y_0} = -\frac{1}{2}(\nabla_{e_i} + \frac{1}{2}\langle (i^*(\nabla^{TX})_{y_0}^2 - \sqrt{-1}J^{TX}dad\bar{a})Z, e_i \rangle)^2 \\ + i^*(\nabla^{\xi,2} + \frac{1}{2}\text{Tr}[\nabla^{TX,2}]) - dad\bar{a}\frac{\dim X}{2}.$$

Also using (11.71) at $Z_0 = 0$ and (12.46), we see that the analogue of (11.71) at $Z_0 = 0$ is now

$$(12.48) \quad \frac{c}{\sqrt{2}}(\tau e_i) = \frac{c}{\sqrt{2}}(e_i) + u\left(\left(\langle S_{y_0}^V(Z)e_i, f_{\alpha}^{H,V} \rangle \right. \right. \\ \left. \left. - \langle \nabla_Z^{TX} f_{\alpha,y_0}^{H,N_{Y/X}}, e_i \rangle\right) f^{\alpha} + da \langle z, e_i \rangle + d\bar{a} \langle \bar{z}, e_i \rangle\right) + \mathcal{O}_1(|uZ|^2).$$

Using (12.48) and proceeding as in (12.23)-(12.35), we find that the obvious

extension of the first identity in (12.21) is

$$(12.49) \quad \left\{ \frac{1}{u} f^\alpha \nabla_{f_\alpha^{H,W}}^\xi V + \frac{c(\tau e_i)}{\sqrt{2}} \nabla_{\tau e_i}^\xi V(uZ) \right\}_u^3 = \frac{1}{u} i^* \nabla^\xi V(y_0) + f^\alpha \wedge \left(\tilde{\nabla}_Z^\xi \nabla_{f_\alpha^{H,W}}^\xi V - \nabla_{\nabla_{PTYZ}^{TX} f_\alpha^{H,NY/X} + TV(f_\alpha^{H,V}, PTYZ)}^\xi V \right) (y_0) + \sum_1^{2\ell'} e^i \wedge \tilde{\nabla}_Z^\xi \nabla_{\tau e_i}^\xi V(y_0) + da \nabla_z^\xi V(y_0) + d\bar{a} \nabla_{\bar{z}}^\xi V(y_0) + \mathcal{O}(u(1 + |Z|^2)).$$

By(12.49), the obvious extension of the second identity in (12.22) is

$$(12.50) \quad P^{\xi^-} \left(f^\alpha \wedge \left(\tilde{\nabla}_Z^\xi \nabla_{f_\alpha^{H,W}}^\xi V - \nabla_{\nabla_{PTYZ}^{TX} f_\alpha^{H,NY/X} + TV(f_\alpha^{H,V}, PTYZ)}^\xi V \right) + \sum_{i=1}^{2\ell'} e^i \wedge \tilde{\nabla}_Z^\xi \nabla_{\tau e_i}^\xi V + da \nabla_z^\xi V + d\bar{a} \nabla_{\bar{z}}^\xi V \right) (y_0) P^{\xi^-} = P^{\xi^-} \left(\frac{\sqrt{-1}}{\sqrt{2}} \tilde{c}(AP^{TY} Z) + da \sqrt{-1} \frac{\tilde{c}(z)}{\sqrt{2}} + d\bar{a} \sqrt{-1} \frac{\tilde{c}(\bar{z})}{\sqrt{2}} \right) P^{\xi^-}.$$

By (12.47), (12.49), (12.50) and by proceeding as in Sections 12.1-12.6, we find that given $T > 0$, as $u \rightarrow 0$

$$(12.51) \quad \theta_{u,T/u} \rightarrow \theta_T.$$

To establish (6.83), for greater clarity of the references, we will instead show that there exist $C > 0, \alpha > 0, \beta > 0$ such that for $u \in]0, 1], T \in [u, 1]$,

$$(12.52) \quad \left| \Phi \text{Tr}_s \left[N_{\mathbf{H}} \exp(-A_{u,T/u}^2) \right] - \int_Y \Phi \text{Tr}_s \left[N_{\mathbf{H}} \exp(-\mathfrak{B}_{T^2}^2) \right] \text{ch}(\eta, g^\eta) \right| \leq \frac{Cu^\alpha}{T^\beta}.$$

Given the considerations we made before (12.51), the proof of (6.83) for $h_{u,T} = \theta_{u,T}$ will just be the obvious analogue of our proof of (12.52).

Using (12.2), (12.4), it is clear that to prove (12.52), we only need to show that for $u \in]0, 1], T \in [u, 1]$,

$$(12.53) \quad \left| \Phi \text{Tr}_s \left[N_{\mathbf{H}} \tilde{F}_u(\tilde{A}_{u,T/u}^2) \right] - \int_Y \Phi \text{Tr}_s \left[N_{\mathbf{H}} \exp(-\mathfrak{B}_{T^2}^2) \right] \text{ch}(\eta, g^\eta) \right| \leq \frac{Cu^\alpha}{T^\beta}.$$

By Proposition 9.3,

$$(12.54) \quad \text{Tr}_s \left[N_{\mathbf{H}} \tilde{F}_u(\tilde{A}_{u,T/u}^2) \right] = \psi_{1/\sqrt{T}} \text{Tr}_s \left[N_{\mathbf{H}} \tilde{F}_u(T \tilde{A}_{u/\sqrt{T}, \sqrt{T}/u}^2) \right].$$

Also one verifies easily that

$$(12.55) \quad \int_Y \Phi \operatorname{Tr}_s [N_{\mathbf{H}} \exp(-\mathfrak{B}_{T^2}^2)] \operatorname{ch}(\eta, g^\eta) = \psi_{1/\sqrt{T}} \int_Y \Phi \operatorname{Tr} [N_{\mathbf{H}} \exp(-T\mathfrak{B}_1^2)] \Phi \operatorname{Tr} [\exp(-T\nabla^{\eta,2})].$$

By (12.54), (12.55), we see that (12.53) is equivalent to

$$(12.56) \quad \left| \psi_{1/\sqrt{T}} \left(\Phi \operatorname{Tr}_s [N_{\mathbf{H}} \tilde{F}_u(T\tilde{A}_{u/\sqrt{T},\sqrt{T}/u}^2)] - \int_Y \Phi \operatorname{Tr}_s [N_{\mathbf{H}} \exp(-T\mathfrak{B}_1^2)] \Phi \operatorname{Tr} [\exp(-T\nabla^{\eta,2})] \right) \right| \leq \frac{Cu^\alpha}{T^\beta}.$$

Observe that for $u \in]0, 1], T \in]u, 1]$, then $\frac{u}{\sqrt{T}} \in]0, 1]$. Then to prove (12.56), we only need to show that there exist $C > 0, \alpha > 0, \beta > 0$ such that for $u \in]0, 1], T \in]0, 1]$,

$$(12.57) \quad \left| \Phi \operatorname{Tr}_s [N_{\mathbf{H}} \tilde{F}_u(T\tilde{A}_{u,1/u}^2)] - \int_Y \Phi \operatorname{Tr}_s [N_{\mathbf{H}} \exp(-T\mathfrak{B}_1^2)] \Phi \operatorname{Tr} [\exp(-T\nabla^{\eta,2})] \right| \leq \frac{Cu^\alpha}{T^\beta}.$$

To establish (12.57), we need to refer in some detail to the estimates [19, Section 12]. To make our references to [19] easier, we will work exactly in the context of [19], i.e. when S is a point. The arguments given before make the extension to the general case quite easy.

Let $\tilde{F}_u(TL_{u,1/u}^{3,y_0}), (Z, Z') (Z, Z' \in (T_{\mathbf{R}}X)_{y_0})$ be the smooth kernel of $\tilde{F}_u(TL_{u,T/u}^{3,y_0})$ with respect to $\frac{dv_X(Z')}{(2\pi)^{\dim X}}$. By using the arguments of [19, proof of Theorem 12.14], one finds easily that for any $m \in \mathbf{N}$, there exist $C > 0, p \in \mathbf{N}$ such that for $u \in]0, 1], T \in]0, 1]$,

$$(12.58) \quad \sup_{\substack{Z_0 \in N_{Y/X, \mathbf{R}, y_0} \\ |Z_0| \leq \varepsilon/4u}} \left| (1 + |Z_0|)^m \tilde{F}_u(TL_{u,1/u}^{3,y_0})(Z_0, Z_0) \right| \leq \frac{C}{T^p},$$

and that given $M > 0, m' \in \mathbf{N}$, there exists $C' > 0, n' \in \mathbf{N}$ that for $u \in]0, 1], T \in]0, 1]$,

$$(12.59) \quad \sup_{\substack{Z, Z' \in (T_{\mathbf{R}}X)_{y_0} \\ |P^{TY} Z|, |P^{TY} Z'| \leq M \\ |P^{NY/X} Z|, |P^{NY/X} Z'| \leq \frac{\varepsilon}{4u} \\ |\alpha|, |\alpha'| \leq m'}} \left| \frac{\partial^{|\alpha|+|\alpha'|}}{\partial Z^\alpha \partial Z'^{\alpha'}} \tilde{F}_u(TL_{u,1/u}^{3,y_0})(Z, Z') \right| \leq \frac{C'}{T^{n'}}.$$

Put

$$(12.60) \quad \begin{aligned} L_{u,1} &= P^{\xi_{y_0}^-} L_{u,1/u}^{3,y_0} P^{\xi_{y_0}^-}, \quad L_{u,2} = P^{\xi_{y_0}^-} L_{u,1/u}^{3,y_0} P^{\xi_{y_0}^+}, \\ L_{u,3} &= P^{\xi_{y_0}^+} L_{u,1/u}^{3,y_0} P^{\xi_{y_0}^-}, \quad L_{u,4} = P^{\xi_{y_0}^+} L_{u,1/u}^{3,y_0} P^{\xi_{y_0}^+}. \end{aligned}$$

Theorem 12.8 — *There exist $C > 0, n \in \mathbf{N}$ such that for $u \in]0, 1], T \in]0, 1], y_0 \in W,$*

$$(12.61) \quad \begin{aligned} \left\| P^{\xi^+} \tilde{F}_u(TL_{u,1/u}^{3,y_0}) P^{\xi^+} \right\|_{u,1/u}^0 &\leq \frac{Cu}{T^n}, \\ \left\| P^{\xi^\pm} \tilde{F}_u(TL_{u,1/u}^{3,y_0}) P^{\xi^\mp} \right\|_{u,1/u}^0 &\leq \frac{Cu}{T^n}. \end{aligned}$$

Proof. By [19, eq. (12.79)],

$$(12.62) \quad |s^+|_{u,1/u,0,0} \leq Cu |s|_{u,1/u,0,1}.$$

□

By [19, eq. (12.71)], for $u \in]0, 1], \lambda \in U,$

$$(12.63) \quad \left\| (\lambda - L_{u,1/u}^{3,y_0})^{-1} \right\|_{u,1/u,0}^{-1,1} \leq C(1 + |\lambda|)^2.$$

From (12.62), (12.63), we deduce that if $s \in \mathbf{I}_{y_0}^0,$

$$(12.64) \quad \left| \left[(\lambda - L_{u,1/u}^{3,y_0})^{-1} s \right]^+ \right|_{u,1/u,0,0} \leq Cu(1 + |\lambda|)^2 |s|_{u,T/u,0,0}.$$

Put

$$(12.65) \quad E_u = \lambda - L_{u,1} - L_{u,2}(\lambda - L_{u,4})^{-1}L_{u,3}.$$

By [19, eq. (12.71), (12.84)]

$$(12.66) \quad \|E_u\|_{u,1/u,0}^{-1,1} \leq C(1 + |\lambda|)^2.$$

By [19, eq. (12.85)]

$$(12.67) \quad P^{\xi^-} (\lambda - L_{u,1/u}^{3,y_0})^{-1} P^{\xi^+} = E_u^{-1} L_{u,2} (\lambda - L_{u,4})^{-1}.$$

By proceeding as in [19, eq. (12.86)-(12.88)], we obtain

$$(12.68) \quad \|E_u^{-1} L_{u,2} (\lambda - L_{u,4}^{-1}) s^+\|_{u,1/u,0,0} \leq C(1 + |\lambda|)^4 u |s^+|_{u,1/u,0,0}.$$

Recall that the contour Γ in \mathbf{C} was defined in [19, eq. (11.115)]. Then by [19, Theorem 11.30],

$$(12.69) \quad \tilde{F}_u(TL_{u,1/u}^{3,y_0}) = \frac{1}{2\pi i} \int_{\Gamma} \frac{\tilde{F}_u(T\lambda)}{\lambda - L_{u,1/u}^{3,y_0}} d\lambda.$$

Also by [19, Proposition 13.10], given $c > 0, m \in \mathbf{N},$ there is $C > 0,$ such that for $u \in]0, 1]$

$$(12.70) \quad \sup_{a \in \Gamma} |a|^m \left| \tilde{F}_u(a) \right| \leq C.$$

From (12.64), (12.67), (12.68), (12.70), we get (12.61) easily. □

If $s \in \mathbf{I}_{y_0}$ has compact support, if $k = 0, 1, k' \in \mathbf{N}$, put

$$(12.71) \quad |s|_{u,T,0,(k,k')}^2 = \sum_{|\alpha| \leq k'} |Z^\alpha s|_{u,T,0,k}^2.$$

Now we establish a refined version of [19, Theorem 12.16], closely related to [19, Theorem 11.35] and [19, Theorem 13.41].

Theorem 12.9 — *There exists $C > 0$ such that if $\sigma \in \mathbf{I}_{y_0}^-$ has compact support, for $u \in]0, 1]$, $\lambda \in \Gamma$,*

$$(12.72) \quad \left| (L_{u,1} + L_{u,2}(\lambda - L_{u,4})^{-1}L_{u,3} - \mathfrak{B}_1^{2,y_0} - \nabla_{y_0}^{\eta,2})\sigma \right|_{u,1/u,0,-1} \leq C(1 + |\lambda|)^2 u |\sigma|_{u,1/u,0,(1,4)}.$$

Proof. The proof of (12.72) will consist in following in detail the inequalities in [19, eq. (12.93)-(12.118)]. In particular the dependence of the constants on $\lambda \in \mathbf{C}$ will be made more explicit. The precise version of [19, eq. (12.95)] is

$$(12.73) \quad \left| (L_{u,1} - P^{\xi_{y_0}} M_0^{3,y_0} - \frac{\sqrt{-1}}{\sqrt{2}} \hat{c}(AP^{TY} Z) - S_{y_0} - \frac{|P^{N_{Y/X}} Z|^2}{2})\sigma \right|_{u,1/u,0,-1} \leq Cu |\sigma|_{u,1/u,0,(1,4)}.$$

In the right-hand sides of [19, eq. (12.99), (12.100), (12.103)] C should be replaced by $C(1 + |\lambda|)^2$. Also from [19, eq. (12.111)], we get

$$(12.74) \quad |L''_{0,2}(\lambda - L_{u,4})^{-1}L'_{u,4}(\lambda u^2 - L'''_{u,4})^{-1}L''_{0,3}\sigma|_{u,1/u,0,-1} \leq C(1 + |\lambda|)^2 u |\sigma|_{u,1/u,0,1}.$$

Finally, instead of [19, eq. (12.115)], we have

$$(12.75) \quad |(L''_{0,2}(\lambda u^2 - L'''_{u,4})^{-1}L''_{0,3} + L''_{0,2}(L'''_{0,4})^{-1}L''_{0,3})\sigma|_{u,1/u,0,-1} \leq C(1 + |\lambda|)u |\sigma|_{u,1/u,0,(0,1)}.$$

Using (12.73)-(12.75), and proceeding as in [19, eq. (12.117), (12.118)], we get (12.72). □

If $s \in \mathbf{I}_{y_0}$ has compact support, let $|s|_{0,0}$ be the limit as $u \rightarrow 0$ of $|s|_{u,1/u,0,0}$. As in [19, Definition 12.15], if $s \in \mathbf{I}_{y_0}^-$, put

$$(12.76) \quad |s|_{0,1}^{-,2} = |s|_{0,0}^2 + \frac{||P^{N_{Y/X}} Z|s|_{0,0}^2}{2} + \sum_{i=1}^{2\ell} |\nabla_{e_i} s|_{0,0}^2.$$

If $k = 0, 1, k' \in \mathbf{N}$, if $s \in \mathbf{I}_{y_0}^-$, set

$$(12.77) \quad |s|_{0,(k,k')}^{-,2} = \sum_{|\alpha| \leq k'} |Z^\alpha s|_{0,k}^2.$$

Then by using the notation of [19, p. 195], by [19, eq. (12.72)], if $\lambda \in U$,

$$(12.78) \quad \left\| (\lambda - \mathfrak{B}_1^{2,y_0} - \nabla_{y_0}^{\eta,2})^{-1} \right\|_0^{-1,1} \leq C(1 + |\lambda|)^2.$$

Also by proceeding as in [19, Proposition 11.34], given $k \in \mathbf{N}$, there is $p \in \mathbf{N}$ such that

$$(12.79) \quad \left\| (\lambda - \mathfrak{B}_1^{2,y_0} - \nabla_{y_0}^{\eta,2})^{-1} s \right\|_{0,(1,k)}^- \leq C(1 + |\lambda|)^p \|s\|_{1,(0,k)}^-.$$

Theorem 12.10 — *There exist $C > 0, q \in \mathbf{N}$ such that for $u \in]0, 1], T \in]0, 1], y_0 \in Y, \lambda \in U$, if $s \in \mathbf{I}_{y_0}^-$ has compact support,*

$$(12.80) \quad \left| \left[P^{\xi^-} (\lambda - L_{u,1/u}^{3,y_0})^{-1} P^{\xi^-} - (\lambda - \mathfrak{B}_1^{2,y_0} - \nabla_{y_0}^{\eta,2})^{-1} \right] s \right|_{u,1/u,0,0} \leq C u (1 + |\lambda|)^q |s|_{0,(0,4)}.$$

Proof. Recall that E_u was defined in (12.65). By [19, eq. (12.82)]

$$(12.81) \quad E_u^{-1} = P^{\xi^-} (\lambda - L_{u,1/u}^{3,y_0})^{-1} P^{\xi^-}.$$

Then

$$(12.82) \quad E_u^{-1} - (\lambda - \mathfrak{B}_1^{2,y_0} - \nabla_{y_0}^{\eta,2})^{-1} = E_u^{-1} (L_{u,1} + L_{u,2} (\lambda - L_{u,4})^{-1} L_{u,3} - \mathfrak{B}_1^{2,y_0} - \nabla_{y_0}^{\eta,2}) (\lambda - \mathfrak{B}_1^{2,y_0} - \nabla_{y_0}^{\eta,2})^{-1}.$$

Using (12.66), (12.72), (12.79), (12.82), we get (12.80). □

Clearly

$$(12.83) \quad P^{\xi^-} \tilde{F}_u(T \mathcal{L}_{u,1/u}^{3,y_0}) P^{\xi^-} - \tilde{F}_u(T (\mathfrak{B}_1^{2,y_0} + \nabla_{y_0}^{\eta,2})) = \frac{1}{2\pi i} \int_{\Gamma} F_u(T \lambda) \left((\lambda - L_{u,1/u}^{3,y_0})^{-1} - (\lambda - \mathfrak{B}_1^{2,y_0} - \nabla_{y_0}^{\eta,2})^{-1} \right) d\lambda.$$

By (12.70) and by Theorems 12.8 and 12.10, we find that there exist $C > 0, k > 0$ such that if $s \in \mathbf{I}_{y_0}^-$ has compact support,

$$(12.84) \quad \left| (\tilde{F}_u(T \mathcal{L}_{u,1/u}^{3,y_0}) - P^{\xi^-} \tilde{F}_u(T (\mathfrak{B}_1^{2,y_0} + \nabla_{y_0}^{\eta,2})) P^{\xi^-}) s \right|_{u,1/u,0,0} \leq \frac{C u |s|_{0,(0,4)}}{T^k}.$$

Take $A \in N_{Y/X, \mathbf{R}, y_0}$. Let $J_{y_0}^A$ be the Hilbert space of L_2 sections of $(\Lambda(T^{*(0,1)}X) \widehat{\otimes} \xi)_{y_0}$ over $\{Z \in (T_{\mathbf{R}}X)_{y_0}, |Z - A| \leq 3/2\}$. We equip $J_{y_0}^A$ with the natural obvious L_2 Hermitian product.

If $\mathfrak{B} \in \mathcal{L}(J_{y_0}^A)$, let $\|\mathfrak{B}\|_{\infty}^A$ be the corresponding norm. By (12.84), we get

$$(12.85) \quad \left\| \tilde{F}_u(T\mathcal{L}_{u,1/u}^{3,y_0}) - P^{\xi^-} \tilde{F}_u(T(\mathfrak{B}_1^{2,y_0} + \nabla_{y_0}^{\eta,2})) P^{\xi^-} \right\|_{\infty}^A \leq \frac{Cu(1 + |A|)^{2\ell'+4}}{T^k}.$$

Using (12.58), (12.59), (12.85) and proceeding as in [19, Section 11 p)], we find that if $Z_0 \in N_{Y/X, \mathbf{R}, y_0}$, $|Z_0| \leq \frac{\varepsilon}{8u}$,

$$(12.86) \quad \left| (\tilde{F}_u(T\mathcal{L}_{u,1/u}^{3,y_0}) - P^{\xi^-} \tilde{F}_u(T(\mathfrak{B}_1^{2,y_0} + \nabla_{y_0}^{\eta,2})) P^{\xi^-})(Z_0, Z_0) \right| \leq \frac{Cu^{\alpha}(1 + |Z_0|)^{2\ell'+4}}{T^{\beta}}.$$

Also from (11.10), one gets the easy estimate

$$(12.87) \quad \left| \left(\tilde{F}_u(T(\mathfrak{B}_1^{2,y_0} + \nabla_{y_0}^{\eta,2})) - \exp(-T(\mathfrak{B}_1^{2,y_0} + \nabla_{y_0}^{\eta,2})) \right) (Z_0, Z_0) \right| \leq \frac{C \exp(-1/u^2)}{T^{n'}}.$$

Finally using (12.70) and proceeding as in [19, Theorems 11.27-11.31], we see that for any $m \in \mathbf{N}$, there exist $C > 0$, $m' \in \mathbf{N}$ such that for $u \in]0, 1]$, $T \in]0, 1]$,

$$(12.88) \quad \sup_{Z_0 \in N_{Y/X, \mathbf{R}, y_0}} \left| (1 + |Z_0|)^m \tilde{F}_u(T(\mathfrak{B}_1^{2,y_0} + \nabla_{y_0}^{\eta,2}))(Z_0, Z_0) \right| \leq \frac{C}{T^{m'}},$$

and that given $M > 0$, $n' \in \mathbf{N}$, there exist $C' > 0$, $m' \in \mathbf{N}$ such that for $u \in]0, 1]$, $T \in]0, 1]$,

$$(12.89) \quad \sup_{\substack{Z, Z' \in (T_{\mathbf{R}}X)_{y_0} \\ |P^{TY}Z|, |P^{TY}Z'| \leq M}} \left| \frac{\partial^{|\alpha|+|\alpha'|}}{\partial Z^{\alpha} \partial Z'^{\alpha'}} \tilde{F}_u \left(T(\mathfrak{B}_1^{2,y_0} + \nabla_{y_0}^{\eta,2}) \right) (Z, Z') \right| \leq \frac{C}{T^{n'}}.$$

By (12.58), (12.59), (12.86)-(12.89), we find that for any $m \in \mathbf{N}$, there exist $C > 0$, $\alpha > 0$, $\beta > 0$ such that for $y_0 \in Y$, $Z_0 \in N_{Y/X, \mathbf{R}, y_0}$, $|Z_0| \leq \varepsilon/8u$,

$$(12.90) \quad \left| (\tilde{F}_u(T\mathcal{L}_{u,1/u}^{3,y_0}) - P^{\xi^-} \exp(-T(\mathfrak{B}_1^{2,y_0} + \nabla_{y_0}^{\eta,2}))(Z_0, Z_0) \right| \leq \frac{Cu^{\alpha}}{T^{\beta}(1 + |Z_0|)^m}.$$

Finally by making $u \rightarrow 0$ in (12.87), and using (12.88) (or by a direct proof) for any $m \in \mathbf{N}$, there exist $C > 0$, $m' \in \mathbf{N}$ such that if $Z_0 \in N_{Y/X, \mathbf{R}, y_0}$,

$$(12.91) \quad (1 + |Z_0|)^m \left| \exp(-T(\mathfrak{B}_1^{2,y_0} + \nabla_{y_0}^{\eta,2}))(Z_0, Z_0) \right| \leq \frac{C}{T^{m'}}.$$

Using (12.13), (12.90), (12.91), we get

$$(12.92) \quad \left| \int_Y \int_{\substack{Z_0 \in N_{Y/X, \mathbf{R}, \nu_0} \\ |Z_0| \leq \varepsilon/8}} \Phi \operatorname{Tr}_s \left[N_{\mathbf{H}} \tilde{F}_u(T \tilde{A}_{u,1/u}^2)(Z_0, Z_0) \right] \frac{dv_X(y_0, Z_0)}{(2\pi)^{\dim X}} \right. \\ \left. - \int_Y \Phi \operatorname{Tr}_s [\exp(-T \mathfrak{R}_1^2)] \Phi \operatorname{Tr} [\exp(-\nabla^{\eta,2})] \right| \leq \frac{Cu^\alpha}{T^\beta}.$$

By also using (12.92) in the case where $Y = \phi$ as in [19, Remark 11.14], (12.57) follows easily from (12.92).

We have then completed the proof of the first half of Theorem 6.18. \square

13. The analysis of the two parameter operator $\exp(-A_{u,T}^2)$ in the range $u \in]0, 1]$, $T \geq 1/u$

The purpose of this Chapter is to prove Theorems 6.9, the second half of Theorem 6.18 and Theorem 6.19. This Chapter is the extension of [19, Section 13], where Theorem 6.9 established when S is a point.

For $0 \leq u_0 \leq u \leq 1$, the techniques of Chapters 8 and 9 can be used. However, here, one of the main points is to obtain uniformity of the convergence in (6.22) for $u \in]0, 1]$, $T \geq 1/u$. We are thus forced to use relative local index techniques. In particular, while in Chapter 9, the bundle $\Lambda(T^{*(0,1)}X)$ in directions normal to W was trivialized using the connection $\nabla^{\Lambda(T^{*(0,1)}X)}$, here we have to trivialize the bundle $\pi_V^* \Lambda(T_{\mathbf{R}}^* S) \hat{\otimes} \Lambda(T^{*(0,1)}X)$ in directions normal to W using a connection which is essentially the fibrewise connection ${}^2\nabla^{\pi_V^* \Lambda(T_{\mathbf{R}}^* S) \hat{\otimes} \Lambda(T^{*(0,1)}X)}$ already considered in Chapter 11. The algebra is more involved than in [19, Section 13], but once the right coordinates and trivializations are found, the functional analytic machine of [19, Section 13] can be used without any substantial change. Still, inequality (6.84) in Theorem 6.18 gives a bound on a speed of convergence as $u \rightarrow 0$, which is uniform in $T \in [1, +\infty[$. Such a problem was not considered in [19], but the techniques of [19] can also be used to solve this problem.

The organization of the Chapter is closely related to the organization of [19, Section 13]. In Section 13.1, we show that the proof of Theorem 6.9 is local on a fibre X . In Sections 13.2 and 13.3, we construct a coordinate system and a trivialization of $\pi_V^* \Lambda(T_{\mathbf{R}}^* S) \hat{\otimes} \Lambda(T^{*(0,1)}X) \hat{\otimes} \xi$ near $y_0 \in W$. In Section 13.4, we replace X by $(T_{\mathbf{R}}X)_{y_0}$. In Section 13.5, we rescale the coordinate $Z \in (T_{\mathbf{R}}X)_{y_0}$, and we use a Getzler rescaling [23], [3] on certain Clifford variables. The operator $\tilde{A}_{u,T/u}^2$ is then replaced by an operator $\mathcal{L}_{u,T}^{3,y_0}$. In Section 13.6, we give an explicit formula for $\mathcal{L}_{u,T}^{3,y_0}$ in the considered trivialization. In Section 13.7, we study the asymptotics of $\mathcal{L}_{u,T}^{3,y_0}$ as $u \rightarrow 0$. This permits us to recover the results of Section 12 in a different trivialization. In Section 13.8, we study the asymptotics of the operator $\mathcal{L}_{u,T}^{3,y_0}$ as $T \rightarrow +\infty$, when the operator $\mathcal{L}_{u,T}^{3,y_0}$ is written as a $(3, 3)$ matrix with respect to a natural splitting of the vector space $\mathbf{K}_{y_0}^0$ on which $\mathcal{L}_{u,T}^{3,y_0}$ acts as an unbounded operator. In Section 13.9, we

calculate the asymptotics as $T \rightarrow +\infty$ of $F_T k^{1/2} \tilde{A}_{1,T} k^{-1/2} F_T^{-1}$ in the trivialization of $\pi_V^* \Lambda(T_{\mathbf{R}}^* S) \hat{\otimes} \Lambda(T^{*(0,1)} X)$ which was described before. While the trivialization is more complicate than in Chapter 8, the asymptotics is simpler. Then we relate the asymptotics of $\mathcal{L}_{u,T}^{3,y_0}$ as $T \rightarrow +\infty$ to the asymptotics of $(F_T k^{1/2} \tilde{A}_{u,T} k^{-1/2} F_T^{-1})^2$. In Section 13.10, we introduce a new family of Sobolev norms depending on u, T , which extend corresponding norms already constructed in [19, Section 13 k)]. These Sobolev norms incorporate the grading of the Grassmann variables in $\pi_V^* \Lambda(T_{\mathbf{R}}^* S)$, so as to permit an analysis of $\mathcal{L}_{u,T}^{3,y_0}$ very similar to the one given in [19, Section 13]. In Section 13.11, we introduce a fibrewise elliptic differential operator $\Xi_u^{y_0}$, which is the analogue of an operator introduced in [19, Section 13 o)].

In Section 13.12, we take advantage of the formal similarities with [19, Section 13] to give a short proof of Theorem 6.9.

In Section 13.13, we prove Theorem 6.19, and in Section 13.14 we establish the second half of Theorem 6.18. The algebra involved in the proofs of both Theorems is more complicate than before. The fact that ultimately, the algebra simplifies is a little miracle. The organization of Section 13.13 reproduces the organization of the whole Chapter. In Section 13.14, in our proof of the second half of Theorem 6.18, we explain how to adapt the techniques of [19] to establish a result which has no explicit analogue in [19].

In this Chapter, we use the assumptions and notation of Chapters 3, 5, 6-9 and 11-12.

13.1 A proof of Theorem 6.9: the problem is localizable on W

We fix $\varepsilon > 0$ such that $\varepsilon \in]0, \frac{1}{2} \inf(a^X, a^Y, \varepsilon_0)]$. Let $\alpha \in]0, \frac{1}{8} \inf(a^X, a^Y, \varepsilon_0)]$. The precise value of α will be determined in Section 13.3.

We use the notation of Section 11.2.

Theorem 13.1 — *There exist $c > 0, C > 0, \delta \in]0, 1]$, such that for $u \in]0, 1], T \geq 1$,*

$$(13.1) \quad \left| \Phi \operatorname{Tr}_s \left[N_{\mathbf{H}} \tilde{G}_u(A_{u,T/u}^2) \right] - \frac{\dim N_{Y/X}}{2} \Phi \operatorname{Tr}_s \left[\tilde{G}_u(B_{u^2}^{W,2}) \right] \right| \leq \frac{c}{T^\delta} \exp\left(\frac{-C}{u^2}\right).$$

Proof. By (11.24), (11.25), we get

$$(13.2) \quad \operatorname{Tr}_s \left[N_{\mathbf{H}} \tilde{G}_u(A_{u,T/u}^2) \right] = \psi_u \operatorname{Tr}_s \left[N_{\mathbf{H}} \tilde{H}_u(\tilde{A}_{T/u^2}^2) \right].$$

Using (11.21), (13.2), and proceeding as in Chapter 9, we find that there is $C > 0, C' > 0, \delta \in]0, 1]$ such that for $u \in]0, 1], T \geq 1$

$$(13.3) \quad \left| \operatorname{Tr}_s \left[N_{\mathbf{H}} \tilde{H}_u(\tilde{A}_{T/u^2}^2) \right] - \operatorname{Tr}_s \left[q N_{\mathbf{H}} \tilde{G}_u(B_1^{W,2}) \right] \right| \leq C \left(\frac{u^2}{T} \right)^\delta \exp\left(\frac{-C'}{u^2}\right).$$

By Theorem 8.8 and by (13.2), (13.3), we get (13.1). □

In view of Theorem 13.1, to prove Theorem 6.9, we only need to show that there exist $C > 0$, $\delta > 0$ such that

$$(13.4) \quad \left| \text{Tr}_s \left[N_{\mathbf{H}} \tilde{F}_u(A_{u,T/u}^2) \right] - \frac{\dim N_{Y/X}}{2} \text{Tr}_s \left[\tilde{F}_u(B_u^{W,2}) \right] \right| \leq \frac{C}{T^\delta}.$$

Let $\tilde{F}_u(A_{u,T/u}^2)(x, x')$ ($x, x' \in X$) be the smooth kernel of $\tilde{F}_u(A_{u,T/u}^2)$ with respect to $\frac{dv_X(x')}{(2\pi)^{\dim X}}$. As we saw after (11.29), $\tilde{F}_u(A_{u,T/u}^2)(x, x)$ depends only on the restriction of $A_{u,T/u}^2$ to $B^X(x, \alpha)$.

By (7.10), we get

$$(13.5) \quad \int_{\mathfrak{q}_{u,\varepsilon/s}} \text{Tr}_s \left[N_{\mathbf{H}} \tilde{F}_u(A_{u,T/u}^2) \right] \frac{dv_X(x)}{(2\pi)^{\dim X}} = \left(\frac{1}{2\pi} \right)^{\dim X} \int_Y \left\{ \int_{|Z_0| \leq \frac{\varepsilon\sqrt{T}}{8u}} \left(\frac{u}{\sqrt{T}} \right)^{2 \dim N_{Y/X}} \text{Tr}_s \left[N_{\mathbf{H}} \tilde{F}_u(A_{u,T/u}^2) \left(\left(y_0, \frac{uZ_0}{\sqrt{T}} \right), \left(y_0, \frac{uZ_0}{\sqrt{T}} \right) \right) \right] k \left(y_0, \frac{uZ_0}{\sqrt{T}} \right) dv_{N_{Y/X}}(Z_0) \right\} dv_Y(y_0).$$

Now we state an extension of [19, Theorem 13.6].

Theorem 13.2 — *If $\varepsilon \in]0, \frac{1}{2} \inf(\varepsilon_0, a^X, a^Y)]$, $\alpha \in]0, \frac{1}{8} \inf(\varepsilon_0, a^X, a^Y)]$ are small enough, for any $p \in \mathbf{N}$, there exist $C > 0$ such that for $u \in]0, 1]$, $T \geq 1$, $y_0 \in W$, $Z_0 \in N_{Y/X, \mathbf{R}, y_0}$, $|Z_0| \leq \frac{\varepsilon\sqrt{T}}{8u}$, then*

$$(13.6) \quad (1 + |Z_0|)^p \left(\frac{u}{\sqrt{T}} \right)^{2 \dim N_{Y/X}} \left| \text{Tr}_s \left[N_{\mathbf{H}} \tilde{F}_u(A_{u,T/u}^2) \left(\left(y_0, \frac{uZ_0}{\sqrt{T}} \right), \left(y_0, \frac{uZ_0}{\sqrt{T}} \right) \right) \right] \right| \leq C.$$

There exist $C' > 0$, $\delta' \in]0, 1/2]$ such that for any $u \in]0, 1]$, $T \geq 1$, $y_0 \in W$, $Z_0 \in N_{Y/X, \mathbf{R}, y_0}$, $|Z_0| \leq \frac{\varepsilon\sqrt{T}}{8u}$, then

$$(13.7) \quad \left| \left(\frac{1}{2\pi} \right)^{\dim X} \left(\frac{u}{\sqrt{T}} \right)^{2 \dim N_{Y/X}} \text{Tr}_s \left[N_{\mathbf{H}} \tilde{F}_u(A_{u,T/u}^2) \left(\left(y_0, \frac{uZ_0}{\sqrt{T}} \right), \left(y_0, \frac{uZ_0}{\sqrt{T}} \right) \right) \right] - \frac{\exp(-|Z_0|^2) \dim N_{Y/X}}{\pi^{\dim N_{Y/X}}} \frac{\dim N_{Y/X}}{2} \left(\frac{1}{2\pi} \right)^{\dim Y} \text{Tr}_s \left[\tilde{F}_u(B_u^{W,2}) \right] (y_0, y_0) \right| \leq \frac{C}{T^{\delta'}}.$$

Remark 13.3. By proceeding as in [19, Remark 13.7], from Theorem 13.2, one gets (13.4) easily.

We will then concentrate on the proof of Theorem 13.2.

13.2 An orthogonal splitting of TX and a connection on TX

On W , we have the splitting of C^∞ vector bundles

$$(13.8) \quad TX|_W = TY \oplus N_{Y/X}.$$

Definition 13.4. If $y_0 \in W$, $Z_0 \in N_{Y/X, \mathbf{R}, y_0}$, $|Z_0| \leq \varepsilon$, let $TX_{\exp_{y_0}^X(Z_0)}^1$, $TX_{\exp_{y_0}^X(Z_0)}^2$ be the subspaces of $TX_{\exp_{y_0}^X(Z_0)}$ which are obtained from TY_{y_0} , $N_{Y/X, y_0}$ by parallel transport with respect to ∇^{TX} along the curve $t \in [0, 1] \rightarrow \exp_{y_0}^X(tZ)$.

Then TX^1 , TX^2 are smooth vector subbundles of $TX|_{\mathcal{U}_\varepsilon}$ such that

$$(13.9) \quad \begin{aligned} TX^1|_W &= TY, \\ TX^2|_W &= N_{Y/X}. \end{aligned}$$

Moreover on \mathcal{U}_ε , TX splits orthogonally into

$$(13.10) \quad TX = TX^1 \oplus TX^2.$$

Let P^{TX^1} , P^{TX^2} be the orthogonal projection operators from TX on TX^1 , TX^2 . Let ∇^{TX^1} , ∇^{TX^2} be the connections on TX^1 , TX^2 ,

$$(13.11) \quad \nabla^{TX^1} = P^{TX^1} \nabla^{TX} \quad , \quad \nabla^{TX^2} = P^{TX^2} \nabla^{TX}.$$

By Proposition 7.2, on W , ∇^{TX^1} , ∇^{TX^2} restrict to ∇^{TY} , $\nabla^{N_{Y/X}}$.

Set

$$(13.12) \quad {}^0\nabla^{TX} = \nabla^{TX^1} \oplus \nabla^{TX^2}.$$

Put

$$(13.13) \quad A' = \nabla^{TX} - {}^0\nabla^{TX}.$$

Then A' is a 1-form on \mathcal{U}_ε with values in endomorphisms of TX exchanging TX^1 and TX^2 .

By construction

$$(13.14) \quad i^* A' = A.$$

Moreover if $y_0 \in W$, $Z_0 \in N_{Y/X, \mathbf{R}, y_0}$, then

$$(13.15) \quad A'_{y_0}(Z_0) = 0.$$

13.3 A local coordinate system near $y_0 \in W$ and a trivialization of $\pi_V^* \Lambda(T_{\mathbf{R}}^* S) \widehat{\otimes} \Lambda(T^{*(0,1)} X) \widehat{\otimes} \xi$

Take $y_0 \in W$. If $U \in (T_{\mathbf{R}} Y)_{y_0}$, let $t \in \mathbf{R} \rightarrow y_t = \exp_{y_0}^Y(TU)$ be the geodesic in the fibre $Y_{\pi_W y_0}$ such that $y|_{t=0} = y_0$, $\frac{dy}{dt}|_{t=0} = U$. Since $\varepsilon \leq \frac{\alpha^Y}{2}$, the map $U \in B_{y_0}^{TY}(0, \varepsilon) \rightarrow \exp_{y_0}^Y(U) \in Y_{\pi_W y_0}$ is a diffeomorphism.

If $U \in (T_{\mathbf{R}} Y)_{y_0}$, $|U| < \varepsilon$, $V \in N_{Y/X, \mathbf{R}, y_0}$, let $\tau_U V \in N_{Y/X, \mathbf{R}, \exp_{y_0}^Y(U)}$ be the parallel transport of V with respect to $\nabla^{N_{Y/X}}$ along $t \in [0, 1] \rightarrow \exp_{y_0}^Y(tU)$.

Recall that π is the projection $N_{Y/X} \rightarrow W$. Then the map

$$(13.16) \quad (U, V) \in B_{y_0}^{TY}(0, \varepsilon) \times N_{Y/X, \mathbf{R}, y_0} \rightarrow (\exp_{y_0}^Y(U), \tau_U V) \in \pi^{-1}(B^Y(y_0, \varepsilon))$$

is a trivialization of $N_{Y/X, \mathbf{R}, y_0}$ over $B^Y(y_0, \varepsilon)$.

If $Z \in (T_{\mathbf{R}} X)_{y_0}$, $Z = U + U'$, $U \in (T_{\mathbf{R}} Y)_{y_0}$, $U' \in N_{Y/X, \mathbf{R}, y_0}$, $|U| < \varepsilon$, $|U'| < \varepsilon$, we identify Z to $\exp_{\exp_{y_0}^Y(U)}^X(\tau_U U') \in \mathcal{U}_\varepsilon$. This identification is a diffeomorphism from $B_{y_0}^{TY}(0, \varepsilon) \times B_{y_0}^{N_{Y/X}}(0, \varepsilon)$ on an open neighbourhood $\mathcal{W}_\varepsilon(y_0)$ of y_0 in $X_{\pi_W y_0}$. In particular

$$(13.17) \quad \mathcal{W}_\varepsilon(y_0) \cap Y_{\pi_W y_0} = B_{y_0}^{TY}(0, \varepsilon) \times \{0\}.$$

Clearly there exists $\alpha_0(\varepsilon) > 0$ such that for $y_0 \in W$, $Z_0 \in N_{Y/X, \mathbf{R}, y_0}$, $|Z_0| \leq \varepsilon/8$, the open Riemannian ball $B^X(Z_0, \alpha_0(\varepsilon))$ is contained in $\mathcal{W}_{\varepsilon/2}(y_0)$. In particular $0 < \alpha_0(\varepsilon) \leq \varepsilon/2 \leq b/4$.

Now we take $\alpha \in]0, \inf(\alpha_0(\varepsilon), \frac{1}{8}a^X, \frac{1}{8}a^Y, \frac{1}{8}\varepsilon_0)]$.

Let ${}^0\nabla^{\Lambda(T^{*(0,1)} X)}$ be the connection induced by ${}^0\nabla^{TX}$ on $\Lambda(T^{*(0,1)} X)$. Then ${}^0\nabla^{\Lambda(T^{*(0,1)} X)}$ induces the corresponding fibrewise connection ${}^0\nabla^{\pi_V^* \Lambda(T_{\mathbf{R}}^* S) \widehat{\otimes} \Lambda(T^{*(0,1)} X)}$ on $\pi_V^* \Lambda(T_{\mathbf{R}}^* S) \widehat{\otimes} \Lambda(T^{*(0,1)} X)$.

Definition 13.5 . Let ${}^3\nabla^{\pi_V^* \Lambda(T_{\mathbf{R}}^* S) \widehat{\otimes} \Lambda(T^{*(0,1)} X)}$ be the connection on $\pi_V^* \Lambda(T_{\mathbf{R}}^* S) \widehat{\otimes} \Lambda(T^{*(0,1)} X)$ along the fibres X over \mathcal{U}_ε ,

$$(13.18) \quad {}^3\nabla^{\pi_V^* \Lambda(T_{\mathbf{R}}^* S) \widehat{\otimes} \Lambda(T^{*(0,1)} X)} = {}^0\nabla^{\pi_V^* \Lambda(T_{\mathbf{R}}^* S) \widehat{\otimes} \Lambda(T^{*(0,1)} X)} + \left\langle \nabla^{TX} f_\alpha^{H, N_{Y/X}} + T^V(f_\alpha^{H, V}, \cdot) - A'(f_\alpha^{H, W}) P^{TX^1}, e_i \right\rangle \frac{f^\alpha c(e_i)}{\sqrt{2}} + \frac{1}{2} \left(\left\langle S^V(\cdot) f_\alpha^{H, W}, f_\beta^{H, W} \right\rangle - \left\langle f_\alpha^{H, N_{Y/X}}, \nabla^{TX} f_\beta^{H, N_{Y/X}} \right\rangle \right) f^\alpha f^\beta.$$

In view of (1.6), (11.35), (11.38), (13.18) and using the fact that $\text{Tr}[A'] = 0$, it is clear that

$$(13.19) \quad {}^2\nabla^{\pi_V^* \Lambda(T_{\mathbf{R}}^* S) \widehat{\otimes} \Lambda(T^{*(0,1)} X)} = {}^3\nabla^{\pi_V^* \Lambda(T_{\mathbf{R}}^* S) \widehat{\otimes} \Lambda(T^{*(0,1)} X)} + \frac{1}{4} \langle A'(\cdot) e_i, e_j \rangle c(e_i) c(e_j) + \left\langle A'(f_\alpha^{H, W}) P^{TX^1}, e_i \right\rangle \frac{f^\alpha c(e_i)}{\sqrt{2}}.$$

Let us observe that by (1.34), (1.35), (13.18), we have the equality of fibrewise connections on W ,

$$(13.20) \quad i^*3\nabla\pi_{\check{V}}^*\Lambda(T_{\mathbf{R}}^*S)\widehat{\otimes}\Lambda(T^{*(0,1)}X) = i^*0\nabla\pi_{\check{V}}^*\Lambda(T_{\mathbf{R}}^*S)\widehat{\otimes}\Lambda(T^{*(0,1)}X) \\ + \sum_{1 \leq i \leq 2\ell'} \langle T^W(f_{\alpha}^{H,W}, \cdot), e_i \rangle \frac{f^{\alpha}c(e_i)}{\sqrt{2}} \\ + \frac{1}{2} \langle S^W(\cdot)f_{\alpha}^{H,W}, f_{\beta}^{H,W} \rangle f^{\alpha}f^{\beta}.$$

By (1.6), (13.20), we get

$$(13.21) \quad i^*3\nabla\pi_{\check{V}}^*\Lambda(T_{\mathbf{R}}^*S)\widehat{\otimes}\Lambda(T^{*(0,1)}X) = i^*0\nabla\pi_{\check{V}}^*\Lambda(T_{\mathbf{R}}^*S)\widehat{\otimes}\Lambda(T^{*(0,1)}X) \\ + \sum_{1 < i \leq 2\ell'} \frac{1}{2} \langle S^W(\cdot)f_{\alpha}^{H,W}, e_i \rangle f^{\alpha}\sqrt{2}c(e_i) \\ + \frac{1}{2} \langle S^W(\cdot)f_{\alpha}^{H,W}, f_{\beta}^{H,W} \rangle f^{\alpha}f^{\beta},$$

i.e. $i^*3\nabla\pi_{\check{V}}^*\Lambda(T_{\mathbf{R}}^*S)\widehat{\otimes}\Lambda(T^{*(0,1)}X)$ is very closely related to the fibrewise connection ${}^1\nabla\pi_{\check{W}}^*\Lambda(T_{\mathbf{R}}^*S)\widehat{\otimes}\Lambda(T^{*(0,1)}Y)$ attached to (π_W, T^HW, g^{TY}) .

Put

$$(13.22) \quad 3\nabla\pi_{\check{V}}^*\Lambda(T_{\mathbf{R}}^*S)\widehat{\otimes}\Lambda(T^{*(0,1)}X)_{,u} = \psi_u 3\nabla\pi_{\check{V}}^*\Lambda(T_{\mathbf{R}}^*S)\widehat{\otimes}\Lambda(T^{*(0,1)}X)\psi_u^{-1}.$$

Take $u \in]0, 1]$. If $Z \in (T_{\mathbf{R}}X)_{y_0}$, $Z = U + U'$, $U \in (T_{\mathbf{R}}Y)_{y_0}$, $U' \in N_{Y/X, \mathbf{R}, y_0}$, $|U| < \varepsilon$, $|U'| < \varepsilon$, we identify $(\pi_{\check{V}}^*\Lambda(T_{\mathbf{R}}^*S) \widehat{\otimes} \Lambda(T^{*(0,1)}X))_Z$ (resp ξ_Z) to $(\pi_{\check{W}}^*\Lambda(T_{\mathbf{R}}^*S) \widehat{\otimes} \Lambda(T^{*(0,1)}X))_{y_0}$ (resp. ξ_{y_0}) by parallel transport with respect to the connection ${}^3\nabla\pi_{\check{V}}^*\Lambda(T_{\mathbf{R}}^*S)\widehat{\otimes}\Lambda(T^{*(0,1)}X)_{,u}$ (resp $\widetilde{\nabla}^{\xi}$) along the curve $t \in [0, 1] \rightarrow 2tU$ ($0 \leq t \leq 1/2$), $U + (2t - 1)U'$ ($\frac{1}{2} \leq t \leq 1$).

Let ${}^2\Gamma_Z^{\pi_{\check{V}}^*\Lambda(T_{\mathbf{R}}^*S)\widehat{\otimes}\Lambda(T^{*(0,1)}X)}$, ${}^3\Gamma_Z^{\pi_{\check{V}}^*\Lambda(T_{\mathbf{R}}^*S)\widehat{\otimes}\Lambda(T^{*(0,1)}X)}$, Γ_Z^{ξ} , $\widetilde{\Gamma}_Z^{\xi}$ be the connection forms of ${}^2\nabla\pi_{\check{V}}^*\Lambda(T_{\mathbf{R}}^*S)\widehat{\otimes}\Lambda(T^{*(0,1)}X)$, ${}^3\nabla\pi_{\check{V}}^*\Lambda(T_{\mathbf{R}}^*S)\widehat{\otimes}\Lambda(T^{*(0,1)}X)$, ∇^{ξ} , $\widetilde{\nabla}^{\xi}$ in the trivialization associated to ${}^3\nabla\pi_{\check{V}}^*\Lambda(T_{\mathbf{R}}^*S)\widehat{\otimes}\Lambda(T^{*(0,1)}X)$, $\widetilde{\nabla}^{\xi}$. By (13.19),

$$(13.23) \quad {}^2\Gamma_Z^{\pi_{\check{V}}^*\Lambda(T_{\mathbf{R}}^*S)\widehat{\otimes}\Lambda(T^{*(0,1)}X)} = {}^3\Gamma_Z^{\pi_{\check{V}}^*\Lambda(T_{\mathbf{R}}^*S)\widehat{\otimes}\Lambda(T^{*(0,1)}X)} + \frac{1}{4} \langle A'(\cdot)e_i, e_j \rangle_Z c(e_i)c(e_j) \\ + \left\langle A'(f_{\alpha}^{H,W})P^{TX^1}, e_i \right\rangle \frac{f^{\alpha}c(e_i)}{\sqrt{2}}.$$

As in (11.36), we find that parallel transport with respect to ${}^3\nabla\pi_{\check{V}}^*\Lambda(T_{\mathbf{R}}^*S)\widehat{\otimes}\Lambda(T^{*(0,1)}X)$ maps $c^1(T_{\mathbf{R}}X)$ into $c^1(T_{\mathbf{R}}X) \oplus T_{\mathbf{R}}^*S$.

By (13.18), it is clear that the curvature of ${}^3\nabla\pi_{\check{V}}^*\Lambda(T_{\mathbf{R}}^*S)\widehat{\otimes}\Lambda(T^{*(0,1)}X)$ is of length ≤ 2 in $\pi_{\check{V}}^*\Lambda(T_{\mathbf{R}}^*S) \widehat{\otimes} c(T_{\mathbf{R}}X)$. By proceeding as in the proof of Theorem 11.11, we see that ${}^3\Gamma^{\pi_{\check{V}}^*\Lambda(T_{\mathbf{R}}^*S)\widehat{\otimes}\Lambda(T^{*(0,1)}X)}$ is of length ≤ 2 in $\pi_{\check{V}}^*\Lambda(T_{\mathbf{R}}^*S) \widehat{\otimes} c(T_{\mathbf{R}}X)$.

By [1, Proposition 3.7], and by proceeding as in (11.46), we get

$$(13.24) \quad {}_3\Gamma_Z^{\pi^* \Lambda(T_{\mathbf{R}}^* S) \widehat{\otimes} \Lambda(T^{*(0,1)} X)}(U) = \frac{1}{2} \left({}_3\nabla^{\pi^* \Lambda(T_{\mathbf{R}}^* S) \widehat{\otimes} \Lambda(T^{*(0,1)} X)} \right)_{y_0}^2(Z, U) \\ + \mathbb{O}_2(|Z|^2)U \text{ if } Z, U \in (T_{\mathbf{R}}Y)_{y_0} \text{ or if } Z, U \in N_{Y/X, \mathbf{R}, y_0}.$$

By construction

$$(13.25) \quad {}_3\Gamma_Z^{\pi^* \Lambda(T_{\mathbf{R}}^* S) \widehat{\otimes} \Lambda(T^{*(0,1)} X)}(U) = 0 \quad \text{if } Z \in (T_{\mathbf{R}}Y)_{y_0}, U \in N_{Y/X, \mathbf{R}, y_0}.$$

Also by using the definition of curvature, we find easily that

$$(13.26) \quad {}_3\Gamma_Z^{\pi^* \Lambda(T_{\mathbf{R}}^* S) \widehat{\otimes} \Lambda(T^{*(0,1)} X)}(U) = \left({}_3\nabla^{\pi^* \Lambda(T_{\mathbf{R}}^* S) \widehat{\otimes} \Lambda(T^{*(0,1)} X)} \right)_{y_0}^2(Z, U) \\ + \mathbb{O}_2(|Z|^2)U \quad \text{if } Z \in N_{Y/X, \mathbf{R}, y_0}, U \in (T_{\mathbf{R}}Y)_{y_0}.$$

13.4 Replacing X by $(T_{\mathbf{R}}X)_{y_0}$

If $U \in (T_{\mathbf{R}}X)_{y_0}$, $Z \in \mathcal{W}_\varepsilon(y_0)$, let ${}^0\tau U(Z)$ be the parallel transport of U with respect to ${}^0\nabla^{TX}$ along the curve $t \in [0, 1] \rightarrow 2tP^{TY}Z$, $0 \leq t \leq 1/2$, $P^{TY}Z + (2t - 1)P^{N_{Y/X}}Z$, $\frac{1}{2} \leq t \leq 1$.

If $y_0 \in Y$, $U \in (T_{\mathbf{R}}Y)_{y_0}$, put

$$(13.27) \quad \mu(U) = \gamma \left(\frac{4|U|}{3a^Y} \right).$$

Then

$$(13.28) \quad \mu(U) = 1 \quad \text{if } |U| \leq \frac{3a^Y}{8}, \\ = 0 \quad \text{if } |U| \geq \frac{3a^Y}{4}.$$

Let Δ^{TY} be the Euclidean Laplacian on $(T_{\mathbf{R}}Y)_{y_0}$. Let $e_1, \dots, e_{2\ell'}$ be an orthonormal basis of $(T_{\mathbf{R}}Y)_{y_0}$.

Definition 13.6. Let L be the differential operator on $(T_{\mathbf{R}}X)_{y_0}$,

$$(13.29) \quad L = (1 - \mu^2(P^{TY}Z))\Delta^{TY} + \mu^2(P^{TY}Z) \sum_1^{2\ell'} \nabla_{\tau e_i}^2(P^{TY}Z).$$

Let $(a, b) \in \mathbf{R}^2 \rightarrow \kappa(a, b) \in [0, 1]$ be a smooth function such that

$$(13.30) \quad \kappa(a, b) = 1 \quad \text{if } |a| \leq 1/2, |b| \leq 1/2, \\ = 0 \quad \text{if } |a| \geq 3/4 \text{ or } |b| \geq 3/4.$$

If $Z \in (T_{\mathbf{R}}X)_{y_0}$, put

$$(13.31) \quad \varphi(Z) = \kappa \left(\frac{|P^{TY} Z|}{\varepsilon}, \frac{|P^{N_{Y/X}} Z|}{\varepsilon} \right).$$

Then

$$(13.32) \quad \begin{aligned} \varphi(Z) &= 1 && \text{if } |P^{TY} Z| \leq \varepsilon/2, |P^{N_{Y/X}} Z| \leq \varepsilon/2, \\ &= 0 && \text{if } |P^{TY} Z| \geq 3\varepsilon/4, \text{ or } |P^{N_{Y/X}} Z| \geq 3\varepsilon/4. \end{aligned}$$

Let $\Delta^{N_{Y/X}}$ be the Laplacian on $N_{Y/X, \mathbf{R}, y_0}$. We still define the vector space \mathbf{H}_{y_0} as in Definition 11.12.

Definition 13.7. For $u > 0, T > 0$, let $\mathcal{L}_{u,T}^{1,y_0}, \mathcal{M}_{u,T}^{1,y_0}$ be the operators acting on \mathbf{H}_{y_0} ,

$$(13.33) \quad \begin{aligned} \mathcal{L}_{u,T}^{1,y_0} &= (1 - \varphi^2(Z)) \left(\frac{-u^2}{2} (L + \Delta^{N_{Y/X}}) + TP^{\xi^-} S_{y_0} P^{\xi^-} \right. \\ &\quad \left. + \frac{T^2}{u^2} (P^{\xi^+} + \frac{|P^{N_{Y/X}} Z|^2}{2} P^{\xi^-}) \right) + \varphi^2(Z) \tilde{A}_{u,T/u}^2, \\ \mathcal{M}_{u,T}^{1,y_0} &= -(1 - \varphi^2(Z)) \frac{u^2}{2} (L + \Delta^{N_{Y/X}}) + \varphi^2(Z) \tilde{B}_{u^2}^{V,2}. \end{aligned}$$

Let $k''(Z)$ be the function defined on $\mathcal{W}_\varepsilon(y_0)$ by

$$(13.34) \quad dv_X(Z) = k''(Z) dv_{TX}(Z).$$

Then $k''_{\mathcal{W}} = 1$.

By construction, $\varphi^2(Z)$ is equal to 1 on $\mathcal{W}_{\varepsilon/2}(y_0)$. Also if $Z_0 \in N_{Y/X, \mathbf{R}, y_0}, |Z_0| < \frac{\varepsilon}{8}$, then $B^X(Z_0, \alpha) \subset \mathcal{W}_{\varepsilon/2}(y_0)$. By using finite propagation speed, it is clear that if $Z_0 \in N_{Y/X, \mathbf{R}, y_0}, |Z_0| \leq \varepsilon/8$,

$$(13.35) \quad \begin{aligned} \text{Tr}_s \left[N_{\mathbf{H}} \tilde{F}_u(A_{u,T/u}^2)((y_0, Z_0), (y_0, Z_0)) \right] k''(y_0, Z_0) \\ = \text{Tr}_s \left[N_{\mathbf{H}} \tilde{F}_u(\mathcal{L}_{u,T}^{1,y_0})(Z_0, Z_0) \right]. \end{aligned}$$

13.5 Rescaling of Z and of the horizontal Clifford variables

For $u > 0, T > 0$, let $G_{u,T}$ be the linear map $\mathbf{H}_{y_0} \rightarrow \mathbf{H}_{y_0}$ given by

$$(13.36) \quad G_{u,T} h(Z) = h \left(\frac{P^{TY} Z}{u} + \frac{\sqrt{T} P^{N_{Y/X}} Z}{u} \right).$$

Set

$$(13.37) \quad \begin{aligned} \mathcal{L}_{u,T}^{2,y_0} &= G_{u,T}^{-1} \mathcal{L}_{u,T}^{1,y_0} G_{u,T}, \\ \mathcal{M}_{u,T}^{2,y_0} &= G_{u,T}^{-1} \mathcal{M}_{u,T}^{1,y_0} G_{u,T}. \end{aligned}$$

Then

$$\mathcal{L}_{u,T}^{2,y_0}, \mathcal{M}_{u,T}^{2,y_0} \in (\pi_W^* \Lambda(T_{\mathbf{R}}^* S) \widehat{\otimes} c(T_{\mathbf{R}} X) \widehat{\otimes} \text{End}(\xi))_{y_0} \otimes \text{Op}.$$

Let $e_1, \dots, e_{2\ell'}$ be an orthonormal oriented basis of $(T_{\mathbf{R}} Y)_{y_0}$, let $e_{2\ell'+1}, \dots, e_{2\ell}$ be an orthonormal oriented basis of $N_{Y/X, \mathbf{R}, y_0}$. Let $e^1, \dots, e^{2\ell'}$ and $e^{2\ell'+1}, \dots, e^{2\ell}$ be the corresponding dual basis of $(T_{\mathbf{R}} Y)_{y_0}$ and $N_{Y/X, \mathbf{R}, y_0}$.

Recall that the vector spaces $\mathbf{K}_{y_0}, \mathbf{K}_{y_0}^\pm$ were defined in Definition 12.2 and that the operators $c_u(e_i)$ were defined in Definition 12.3.

Definition 13.8. Let $\mathcal{L}_{u,T}^{3,y_0}, \mathcal{M}_{u,T}^{3,y_0} \in \text{End}(\mathbf{K}_{y_0})$ be the operators obtained from $\mathcal{L}_{u,T}^{2,y_0}, \mathcal{M}_{u,T}^{2,y_0}$ by replacing the Clifford variables $c(e_i)$ by $c_u(e_i)$ for $1 \leq i \leq 2\ell'$, while leaving unchanged the $c(e_i)$ for $2\ell' + 1 \leq i \leq 2\ell$.

Let $\widetilde{F}_u(\mathcal{L}_{u,T}^{3,y_0})(Z, Z')$ ($Z, Z' \in (T_{\mathbf{R}} X)_{y_0}$) be the smooth kernel associated to $\widetilde{F}_u(\mathcal{L}_{u,T}^{3,y_0})$ with respect to $\frac{dv_{TX}(Z')}{(2\pi)^{\dim X}}$. We still define $[\widetilde{F}_u(\mathcal{L}_{u,T}^{3,y_0})]^{\max}$ as in (12.12).

Proposition 13.9 — For any $u > 0, T > 0, Z_0 \in N_{Y/X, \mathbf{R}, y_0}, |Z_0| \leq \frac{\varepsilon\sqrt{T}}{8u}$, the following identity holds

$$(13.38) \quad \left(\frac{u}{\sqrt{T}}\right)^{2 \dim N_{Y/X}} \text{Tr}_s \left[N_{\mathbf{H}} \widetilde{F}_u(A_{u,T/u}^2) \left(\left(y_0, \frac{uZ_0}{\sqrt{T}} \right), \left(y_0, \frac{uZ_0}{\sqrt{T}} \right) \right) \right] k'' \left(y_0, \frac{uZ_0}{\sqrt{T}} \right) \\ = (-i)^{\dim Y} \text{Tr}_s \left[N_{\mathbf{H}} \left[\widetilde{F}_u(\mathcal{L}_{u,T}^{3,y_0})(Z_0, Z_0) \right]^{\max} \right].$$

Proof. Using (13.35), the proof of our Proposition is the same as [19, Proposition 13.17]. □

If C is smooth section of $\pi_W^* \Lambda(T_{\mathbf{R}}^* S) \widehat{\otimes} c(T_{\mathbf{R}} X) \widehat{\otimes} \text{End}(\xi)$, if $x \in X_{\pi_{y_0}}$ is close enough to y_0 , let $C_u^3(x)$ be the element of $(\pi_W^* \Lambda(T_{\mathbf{R}}^* S) \widehat{\otimes} \text{End}(\Lambda(T_{\mathbf{R}}^* Y)) \widehat{\otimes} c(N_{Y/X, \mathbf{R}}) \widehat{\otimes} \text{End}(\xi))_{y_0}$, which is obtained by using the trivialization indicated in Section 13.3, associated to $\nabla^{\pi_W^* \Lambda(T_{\mathbf{R}}^* S) \widehat{\otimes} \Lambda(T^{*(0,1)} X), u}$, and by applying the transformation of the elements of $c(T_{\mathbf{R}} X)_{y_0}$ of Definition 13.8.

13.6 A formula for $\mathcal{L}_{u,T}^{3,y_0}$

Observe that

$$(13.39) \quad \mathcal{L}_{u,T}^{3,y_0} = \mathcal{M}_{u,T}^{3,y_0} + \varphi^2 \left(uP^{TY}Z + \frac{u}{\sqrt{T}}P^{N_{Y/X}}Z \right) \\ \left(\left\{ \frac{T}{u} f^\alpha \nabla_{f_\alpha^{H,W}}^\xi V + T \frac{c^{(0)\tau e_i}}{\sqrt{2}} \nabla_{0\tau e_i}^\xi V \right\}_u^3 \left(uP^{TY}Z + \frac{u}{\sqrt{T}}P^{N_{Y/X}}Z \right) \right. \\ \left. + \frac{T^2}{u^2} V^2 \left(uP^{TY}Z + \frac{u}{\sqrt{T}}P^{N_{Y/X}}Z \right) \right) + (1 - \varphi^2 \left(uP^{TY}Z + \frac{u}{\sqrt{T}}P^{N_{Y/X}}Z \right)) \\ \left(TP^{\xi^-} S_{y_0} P^{\xi^-} + \frac{T^2}{u^2} P^{\xi^+} + T \frac{|P^{N_{Y/X}}Z|^2}{2} P^{\xi^-} \right).$$

Now we establish an extension of [19, Theorem 13.18].

Theorem 13.10 — *The following identity holds*

$$(13.40) \quad \mathcal{M}_{u,T}^{3,y_0} = -\frac{1}{2} \left(1 - \varphi^2 \left(uP^{TY}Z + \frac{u}{\sqrt{T}}P^{N_{Y/X}}Z \right) \right) (L_{uP^{TY}Z} + T\Delta^{N_{Y/X}}) \\ + \psi_u \varphi^2 \left(uP^{TY}Z + \frac{u}{\sqrt{T}}P^{N_{Y/X}}Z \right) \left\{ -\frac{1}{2} \sum_{i=1}^{2\ell} \left(\sqrt{T} \nabla_{P^{N_{Y/X}}0\tau e_i} (uP^{TY}Z + \frac{u}{\sqrt{T}}P^{N_{Y/X}}Z) \right) \right. \\ \left. + \nabla_{P^{TY}0\tau e_i} (uP^{TY}Z + \frac{u}{\sqrt{T}}P^{N_{Y/X}}Z) + u \left[{}^3\Gamma^{\pi_V \Lambda}(T_{\mathbf{R}}^* S) \widehat{\otimes} \Lambda(T^{*(0,1)}X) ({}^0\tau e_i) \right. \right. \\ \left. \left. + \frac{1}{4} \langle A'({}^0\tau e_i), {}^0\tau e_j, {}^0\tau e_k \rangle c({}^0\tau e_j) c({}^0\tau e_k) \right. \right. \\ \left. \left. + f^\alpha \frac{c}{\sqrt{2}} \left(A'(f_\alpha^{H,W}) P^{TX} 0\tau e_i \right) + \Gamma^\xi({}^0\tau e_i) \right] \left(uP^{TY}Z + \frac{u}{\sqrt{T}}P^{N_{Y/X}}Z \right) \right\}^2 \\ + \frac{1}{2} \left(u\sqrt{T} \nabla_{P^{N_{Y/X}}0\tau e_i} (uP^{TY}Z + \frac{u}{\sqrt{T}}P^{N_{Y/X}}Z) \right) \\ + u \nabla_{P^{TY}0\tau e_i} (uP^{TY}Z + \frac{u}{\sqrt{T}}P^{N_{Y/X}}Z) + \frac{u^2}{2} \left[\left({}^2\Gamma^{\pi_V \Lambda}(T_{\mathbf{R}}^* S) \widehat{\otimes} \Lambda(T^{*(0,1)}X) + \Gamma^\xi \right) \right. \\ \left. \left(\nabla_{0\tau e_i}^{TX} (uP^{TY}Z + \frac{u}{\sqrt{T}}P^{N_{Y/X}}Z) \right) \right] + \frac{u^2}{8} K \left(uP^{TY}Z + \frac{u}{\sqrt{T}}P^{N_{Y/X}}Z \right) \\ + u^2 \left[\frac{1}{4} c({}^0\tau e_i) c({}^0\tau e_j) R'^\xi({}^0\tau e_i, {}^0\tau e_j) + f^\alpha \frac{c({}^0\tau e_i)}{\sqrt{2}} R'^\xi(f_\alpha^{H,W}, {}^0\tau e_i) \right. \\ \left. + \frac{1}{2} f^\alpha f^\beta R'^\xi(f_\alpha^{H,W}, f_\beta^{H,W}) \right] \left(uP^{TY}Z + \frac{u}{\sqrt{T}}P^{N_{Y/X}}Z \right) \left. \right\} \psi_u^{-1}.$$

Proof. Formula (13.40) follows from Theorem 7.20, from (13.19) and from (13.33). \square

Recall that S was defined in (12.20). Since $\xi_{|W}^- \simeq \Lambda N_{Y/X}^* \otimes \eta$, S acts naturally on $\Lambda(T^{*(0,1)}X) \widehat{\otimes} \xi^-|_W$. Now we extend [19, Theorem 13.19].

Theorem 13.11 — For any $y_0 \in Y$, $u \in]0, 1]$, $Z \in (T_{\mathbb{R}X})_{y_0}$ such that $|P^{TY} Z| \leq 3\varepsilon/4u$, then as $T \rightarrow +\infty$,

$$\begin{aligned}
 (13.41) \quad T & \left\{ \frac{1}{u} f^\alpha \wedge \nabla_{f_\alpha^{H,w}}^\xi V + \sum_1^{2\ell'} \frac{c(0\tau e_i)}{\sqrt{2}} \nabla_{0\tau e_i}^\xi V \right\}_u^3 (uP^{TY} Z + \frac{u}{\sqrt{T}} P^{N_{Y/X}} Z) \\
 & = \frac{T}{u} \left\{ f^\alpha \wedge \nabla_{f_\alpha^{H,w}}^\xi V + \sum_1^{2\ell'} u \left\{ \frac{c(0\tau e_i)}{\sqrt{2}} \right\}_u^3 \nabla_{0\tau e_i}^\xi V \right\} (uP^{TY} Z) \\
 & \quad + \sqrt{T} \left\{ f^\alpha \wedge \tilde{\nabla}_{P^{N_{Y/X}} Z}^\xi \nabla_{f_\alpha^{H,w}}^\xi V \right. \\
 & \quad \left. + \sum_1^{2\ell'} u \left\{ \frac{c(0\tau e_i)}{\sqrt{2}} \right\}_u^3 \tilde{\nabla}_{P^{N_{Y/X}} Z}^\xi \nabla_{0\tau e_i}^\xi V \right\} (uP^{TY} Z) + \mathcal{O}(u |P^{N_{Y/X}} Z|^2),
 \end{aligned}$$

$$\begin{aligned}
 T \sum_{2\ell'+1}^{2\ell} & \left\{ \frac{c(0\tau e_i)}{\sqrt{2}} \right\}_u^3 \nabla_{0\tau e_i}^\xi V (uP^{TY} Z + \frac{u}{\sqrt{T}} P^N Z) \\
 & = T \sum_{2\ell'+1}^{2\ell} \frac{c(e_i)}{\sqrt{2}} (\nabla_{0\tau e_i}^\xi V) (uP^{TY} Z) + u\sqrt{T} \sum_{2\ell'+1}^{2\ell} \frac{c(e_i)}{\sqrt{2}} \\
 & \quad \tilde{\nabla}_{P^{N_{Y/X}} Z}^\xi \nabla_{0\tau e_i}^\xi V (uP^{TY} Z) + \mathcal{O}(u |P^{N_{Y/X}} Z|^2), \\
 & \quad \frac{T^2}{u^2} (V^-)^2 (uP^{TY} Z + \frac{u}{\sqrt{T}} P^{N_{Y/X}} Z) = T \frac{|P^{N_{Y/X}} Z|^2}{2} P^{\xi^-} \\
 & + u \frac{\sqrt{T}}{2} \left[\frac{\sqrt{-1}}{\sqrt{2}} \tilde{c}(P^{N_{Y/X}} Z), \tilde{\nabla}_{P^{N_{Y/X}} Z}^\xi \tilde{\nabla}_{P^{N_{Y/X}} Z}^\xi V^- (uP^{TY} Z) \right] + \mathcal{O}(u^2 |P^{N_{Y/X}} Z|^4).
 \end{aligned}$$

Moreover

$$\begin{aligned}
 (13.42) \quad P^{\xi^-} & \left[f^\alpha \wedge \nabla_{f_\alpha^{H,w}}^\xi V + \sum_1^{2\ell'} u \left\{ \frac{c(0\tau e_i)}{\sqrt{2}} \right\}_u^3 \nabla_{0\tau e_i}^\xi V \right] (uP^{TY} Z) P^{\xi^-} = 0, \\
 P^{\xi^-} & \left\{ f^\alpha \wedge \tilde{\nabla}_{P^{N_{Y/X}} Z}^\xi \nabla_{f_\alpha^{H,w}}^\xi V + \sum_1^{2\ell'} u \left\{ \frac{c(e_i)}{\sqrt{2}} \right\}_u^3 \tilde{\nabla}_{P^{N_{Y/X}} Z}^\xi \nabla_{0\tau e_i}^\xi V \right\} (uP^{TY} Z) P^{\xi^-} = 0, \\
 P^{\xi^-} & \sum_{2\ell'+1}^{2\ell} \frac{c(e_i)}{\sqrt{2}} \nabla_{0\tau e_i}^\xi V (uP^{TY} Z) P^{\xi^-} = P^{\xi^-} S_{y_0} P^{\xi^-}.
 \end{aligned}$$

Proof. Clearly, as $T \rightarrow +\infty$

$$(13.43) \quad \frac{T}{u} f^\alpha \wedge \nabla_{f_\alpha^{H,W}}^\xi V(uP^{TY} Z + \frac{u}{\sqrt{T}} P^{N_{Y/X}} Z) =$$

$$\frac{T}{u} f^\alpha \wedge \nabla_{f_\alpha^{H,W}}^\xi V(uP^{TY} Z) + \sqrt{T} f^\alpha \wedge \tilde{\nabla}_{P^{N_{Y/X}} Z}^\xi \nabla_{f_\alpha^{H,W}}^\xi V(uP^{TY} Z) + \mathcal{O}(u |P^{N_{Y/X}} Z|^2).$$

Also since $\nabla_{P^{N_{Y/X}} Z}^{TX} {}^0\tau e_i(uP^{TY} Z) = 0$, using (7.27), (13.18) and by proceeding as in (11.36), the expansion as $T \rightarrow +\infty$ of $T \frac{c({}^0\tau e_i)}{\sqrt{2}} (uP^{TY} Z + \frac{u}{\sqrt{T}} P^{N_{Y/X}} Z)$ with respect to ${}^3\nabla_{P^{TY} Z}^{\pi_V^* \Lambda(T_{\mathbb{R}}^* S)} \hat{\otimes} \Lambda(T^{*(0,1)} X)$ is given by

$$(13.44) \quad T \frac{c({}^0\tau e_i)}{\sqrt{2}} (uP^{TY} Z + \frac{u}{\sqrt{T}} P^{N_{Y/X}} Z) =$$

$$T \frac{c({}^0\tau e_i)}{\sqrt{2}} (uP^{TY} Z) + \mathcal{O}_1(u^2 |P^{N_{Y/X}} Z|^2).$$

From (13.44), we see that as $T \rightarrow +\infty$,

$$(13.45) \quad \left\{ T \frac{c({}^0\tau e_i)}{\sqrt{2}} \right\}_u^3 (uP^{TY} Z + \frac{u}{\sqrt{T}} P^{N_{Y/X}} Z) =$$

$$T \left\{ \frac{c({}^0\tau e_i)}{\sqrt{2}} \right\}_u^3 (uP^{TY} Z) + \mathcal{O}(u |P^{N_{Y/X}} Z|^2).$$

Since for $1 \leq i \leq 2\ell$, ${}^0\nabla_{P^{TY} Z}^{TX} {}^0\tau e_i(uP^{TY} Z) = 0$, by (13.20), we get for $1 \leq i \leq 2\ell'$,

$$(13.46) \quad {}^3\nabla_{P^{TY} Z}^{\pi_V^* \Lambda(T_{\mathbb{R}}^* S)} \hat{\otimes} \Lambda(T^{*(0,1)} X) \frac{c({}^0\tau e_i)}{\sqrt{2}} (uP^{TY} Z) = - \langle T^W(f_\alpha^{H,W}, P^{TY} Z), {}^0\tau e_i \rangle (uP^{TY} Z) f^\alpha.$$

From (13.46), we deduce that in the trivialization associated to ${}^3\nabla_{P^{TY} Z}^{\pi_V^* \Lambda(T_{\mathbb{R}}^* S)} \hat{\otimes} \Lambda(T^{*(0,1)} X)$, for $1 \leq i \leq 2\ell'$, $c({}^0\tau e_i)$ lies in $c(T_{\mathbb{R}} Y) \oplus T_{\mathbb{R}}^* S$. In particular

$$(13.47) \quad \{uc({}^0\tau e_i)(uP^{TY} Z)\}_u^3 = \mathcal{O}(1).$$

From (13.43), (13.45), (13.47), we get the first identity in (13.41).

Since ${}^0\nabla_{P^{TY} Z}^{TX} {}^0\tau e_i(uP^{TY} Z) = 0$, using (13.20), it is clear that for $2\ell' + 1 \leq i \leq 2\ell$

$$(13.48) \quad {}^3\nabla_{P^{TY} Z}^{\pi_V^* \Lambda(T_{\mathbb{R}}^* S)} \hat{\otimes} \Lambda(T^{*(0,1)} X) c({}^0\tau e_i)(uP^{TY} Z) = 0.$$

Therefore for $2\ell' + 1 \leq i \leq 2\ell$,

$$(13.49) \quad \{c({}^0\tau e_i)\}_u^3 (uP^{TY} Z) = c(e_i).$$

From (13.45), (13.49), we get the second identity in (13.41). The third identity was already proved in [19, Theorem 13.19].

The first identity in (13.42) follows from the fact that $V|_W^- = 0$, and also from (7.21) and Theorem 9.8. By [19, Theorem 13.19] and by Theorem 9.8, we get the second identity in (13.42). By Proposition 7.8,

$$(13.50) \quad P^{\xi^-} \sum_{2\ell'+1}^{2\ell} \frac{c(e_i)}{\sqrt{2}} \nabla_{0\tau e_i}^\xi V(uP^{TY}Z)P^{\xi^-} \\ = P^{\xi^-} \left[\frac{1}{2}\sqrt{-1} \sum_{2\ell'+1}^{2\ell} c(e_i)\widehat{c}(0\tau e_i) \right] P^{\xi^-}.$$

Now since $\xi|_W^- \simeq \Lambda N_{Y/X}^* \otimes \eta$ is an identification of holomorphic Hermitian vector bundles, one finds easily that for $2\ell' + 1 \leq i \leq 2\ell$, $\widehat{c}(0\tau e_i)$ is identified to $\widehat{c}(e_i)$. From (13.50), we get the third identity in (13.42). The proof of our Theorem is completed. \square

13.7 The algebraic structure of the operator $\mathcal{L}_{u,T}^{3,y_0}$ as $u \rightarrow 0$

By (13.45), (13.46), (13.49), we see that as $u \rightarrow 0$, if $1 \leq j \leq 2\ell'$,

$$(13.51) \quad u \left\{ \frac{c(0\tau e_j)}{\sqrt{2}} \right\}_u^3 \left(uP^{TY}Z + \frac{u}{\sqrt{T}}P^{N_{Y/X}}Z \right) \\ = e^j \wedge -\frac{u^2}{2}i_{e_j} - u \langle T^W(f_\alpha^{H,W}, P^{TY}Z), e_j \rangle f^\alpha \\ + \mathcal{O} \left(u^2(|P^{TY}Z|^2 + \frac{|P^{N_{Y/X}}Z|^2}{T}) \right),$$

and if $2\ell' + 1 \leq j \leq 2\ell$,

$$(13.52) \quad \left\{ \frac{c(0\tau e_j)}{\sqrt{2}} \right\}_u^3 \left(uP^{TY}Z + \frac{u}{\sqrt{T}}P^{N_{Y/X}}Z \right) = \\ \frac{c(e_j)}{\sqrt{2}} + \mathcal{O} \left(\frac{u}{T} |P^{N_{Y/X}}Z|^2 \right).$$

By construction the ${}^0\tau e_i$ ($1 \leq i \leq 2\ell'$) span $T_{\mathbf{R}}X^1$ and the ${}^0\tau e_j$ ($2\ell' + 1 \leq j \leq 2\ell$) span $T_{\mathbf{R}}X^2$. Since A' exchanges TX^1 and TX^2 ,

$$(13.53) \quad \frac{1}{4} \langle A'^0\tau e_j, {}^0\tau e_k \rangle c(0\tau e_j)c(0\tau e_k) = \\ \frac{1}{2} \sum_{\substack{1 \leq j \leq 2\ell' \\ 2\ell'+1 \leq k \leq 2\ell}} \langle A'^0\tau e_j, {}^0\tau e_k \rangle c(0\tau e_j)c(0\tau e_k).$$

Moreover

$$(13.54) \quad A'(f_\alpha^{H,W})P^{TX^1_0}\tau e_i \in T_{\mathbf{R}}X^2.$$

From (13.51), (13.52), (13.54), we see that as $u \rightarrow 0$,

$$(13.55) \quad \left\{ u \frac{1}{4} \langle A'({}^0\tau e_i) {}^0\tau e_j, {}^0\tau e_k \rangle c({}^0\tau e_j) c({}^0\tau e_k) \right. \\ \left. + f^\alpha \frac{c}{\sqrt{2}} \left(A'(f_\alpha^{H,W})P^{TX^1_0}\tau e_i \right) \right\}_u^3 (uP^{TY}Z + \frac{u}{\sqrt{T}}P^{N_{Y/X}}Z) \\ \rightarrow \sum_{\substack{1 \leq j \leq 2\ell' \\ 2\ell'+1 \leq k \leq 2\ell}} \langle A'_{y_0}(e_i)e_j, e_k \rangle e^j \wedge \frac{c(e_k)}{\sqrt{2}} \\ + f^\alpha \frac{c}{\sqrt{2}} (A'_{y_0}(f_\alpha^{H,W})P^{TY}e_i).$$

From (1.33), (13.14), (13.15), we find that

$$(13.56) \quad \sum_{\substack{1 \leq j \leq 2\ell' \\ 2\ell'+1 \leq k \leq 2\ell}} \langle A'_{y_0}(e_i)e_j, e_k \rangle e^j \wedge \frac{c(e_k)}{\sqrt{2}} + f^\alpha \frac{c}{\sqrt{2}} (A'_{y_0}(f_\alpha^{H,W})P^{TY}e_i) = \\ \sum_{\substack{1 \leq j \leq 2\ell' \\ 2\ell'+1 \leq k \leq 2\ell}} e^j \wedge \frac{c}{\sqrt{2}} (A_{y_0}(e_j)P^{TY}e_i) + f^\alpha \frac{c}{\sqrt{2}} A(f_\alpha^{H,W})P^{TY}e_i,$$

which is equivalent to

$$(13.57) \quad \sum_{\substack{1 \leq j \leq 2\ell' \\ 2\ell'+1 \leq j \leq 2\ell}} \langle A'_{y_0}(e_i)e_j, e_k \rangle e^j \wedge \frac{c(e_k)}{\sqrt{2}} \\ + f^\alpha \frac{c}{\sqrt{2}} (A'_{y_0}(f_\alpha^{H,W})P^{TY}e_i) = -\frac{c}{\sqrt{2}} (AP^{TY}e_i).$$

As we saw after (13.23), ${}^3\nabla\pi_{\check{V}}^*(\Lambda(T_{\mathbf{R}}^*S) \widehat{\otimes} \Lambda(T^{*(0,1)}X))$ is of length ≤ 2 in $\pi_{\check{V}}^*\Lambda(T_{\mathbf{R}}^*S) \widehat{\otimes} c(T_{\mathbf{R}}X)$. By (13.24)-(13.26), it is clear that as $u \rightarrow 0$, $\{u\psi_u {}^3\nabla_{uP^{TY}Z + \frac{u}{\sqrt{T}}P^{N_{Y/X}}Z} \psi_u^{-1}\}_u^3$ has a finite limit given explicitly in terms of the curvature of ${}^3\nabla\pi_{\check{V}}^*\Lambda(T_{\mathbf{R}}^*S) \widehat{\otimes} \Lambda(T^{*(0,1)}X)$ restricted to W , where only the $\frac{c(e_i)}{\sqrt{2}}$ ($1 \leq i \leq 2\ell'$) replaced by $e^i \wedge$ and the f^α survive.

Clearly

$$(13.58) \quad {}^2\nabla\pi_{\check{V}}^*\Lambda(T_{\mathbf{R}}^*S) \widehat{\otimes} \Lambda(T^{*(0,1)}X),_2 = {}^3\nabla\pi_{\check{V}}^*\Lambda(T_{\mathbf{R}}^*S) \widehat{\otimes} \Lambda(T^{*(0,1)}X),_2 \\ + \left[{}^3\nabla\pi_{\check{V}}^*\Lambda(T_{\mathbf{R}}^*S) \widehat{\otimes} \Lambda(T^{*(0,1)}X), {}^2\nabla\pi_{\check{V}}^*\Lambda(T_{\mathbf{R}}^*S) \widehat{\otimes} \Lambda(T^{*(0,1)}X) - {}^3\nabla\pi_{\check{V}}^*\Lambda(T_{\mathbf{R}}^*S) \widehat{\otimes} \Lambda(T^{*(0,1)}X) \right] \\ + \left({}^2\nabla\pi_{\check{V}}^*\Lambda(T_{\mathbf{R}}^*S) \widehat{\otimes} \Lambda(T^{*(0,1)}X) - {}^3\nabla\pi_{\check{V}}^*\Lambda(T_{\mathbf{R}}^*S) \widehat{\otimes} \Lambda(T^{*(0,1)}X) \right)^2.$$

By (13.19),

$$(13.59) \quad \left(2\nabla\pi_{\check{V}}^*\Lambda(T_{\mathbf{R}}^*S)\widehat{\otimes}\Lambda(T^{*(0,1)}X) - 3\nabla\pi_{\check{V}}^*\Lambda(T_{\mathbf{R}}^*S)\widehat{\otimes}\Lambda(T^{*(0,1)}X) \right)^2 = \frac{1}{4} \langle A'^2 e_i, e_j \rangle c(e_i)c(e_j) \\ + \frac{1}{2} \left\langle A'^2(f_{\alpha}^{H,W}, f_{\beta}^{H,W})P^{TX^1}, P^{TX^1} \right\rangle f^{\alpha} f^{\beta} \\ + f^{\alpha} \frac{c}{\sqrt{2}} \left(A'(\cdot)A'(f_{\alpha}^{H,W})P^{TX^1} \right).$$

By [19, eq. (13.61)], if $Z, Z' \in (T_{\mathbf{R}}X)_{y_0}$, if $U, U' \in T_{\mathbf{R}}Y$,

$$(13.60) \quad \langle A'^2(Z, Z')U, U' \rangle = \langle A'^2(U, U')P^{TY}Z, P^{TY}Z' \rangle.$$

Also by (1.33), (13.14), (13.15), if $Z, Z' \in (T_{\mathbf{R}}X)_{y_0}$, $U \in (T_{\mathbf{R}}^HW)_{y_0}$, $U' \in (T_{\mathbf{R}}Y)_{y_0}$,

$$(13.61) \quad \langle A'_{y_0}(Z)A'_{y_0}(U)Z', U' \rangle \\ = \langle A_{y_0}(P^{TY}Z)A_{y_0}(U)Z', U' \rangle \\ = -\langle A_{y_0}(U)Z', A_{y_0}(P^{TY}Z)U' \rangle \\ = -\langle A_{y_0}(U)P^{TY}Z', A_{y_0}(U')P^{TY}Z \rangle \\ = \langle A_{y_0}(U)A_{y_0}(U')P^{TY}Z, P^{TY}Z' \rangle \\ = \langle A_{y_0}(U')A_{y_0}(U)P^{TY}Z', P^{TY}Z \rangle.$$

Moreover, by (13.18), (13.19),

$$(13.62) \quad \left[3\nabla\pi_{\check{V}}^*\Lambda(T_{\mathbf{R}}^*S)\widehat{\otimes}\Lambda(T^{*(0,1)}X), 2\nabla\pi_{\check{V}}^*\Lambda(T_{\mathbf{R}}^*S)\widehat{\otimes}\Lambda(T^{*(0,1)}X) - 3\nabla\pi_{\check{V}}^*\Lambda(T_{\mathbf{R}}^*S)\widehat{\otimes}\Lambda(T^{*(0,1)}X) \right] = \\ \left[0\nabla\pi_{\check{V}}^*\Lambda(T_{\mathbf{R}}^*S)\widehat{\otimes}\Lambda(T^{*(0,1)}X), 2\nabla\pi_{\check{V}}^*\Lambda(T_{\mathbf{R}}^*S)\widehat{\otimes}\Lambda(T^{*(0,1)}X) - 3\nabla\pi_{\check{V}}^*\Lambda(T_{\mathbf{R}}^*S)\widehat{\otimes}\Lambda(T^{*(0,1)}X) \right] \\ + f^{\alpha} \frac{c}{\sqrt{2}} \left(A'(\cdot)(\nabla^{TX} f_{\alpha}^{H,N_{Y/X}} + T^V(f_{\alpha}^{H,V}, \cdot) - A(f_{\alpha}^{H,W})P^{TX^1}) \right) \\ + \left\langle A'(f_{\alpha}^{H,W})P^{TX^1}, \nabla^{TX} f_{\beta}^{H,N_{Y/X}} + T^V(f_{\beta}^{H,V}, \cdot) - A'(f_{\beta}^{H,W})P^{TX^1} \right\rangle f^{\alpha} f^{\beta}.$$

Now we briefly explain how to calculate the limit as $u \rightarrow 0$ of $\left\{ u^2 \psi_u^3 \nabla_{y_0}^{\pi_{\check{V}}^*} \Lambda(T_{\mathbf{R}}^*S) \widehat{\otimes} \Lambda(T^{*(0,1)}X), 2 \right\}_u (Z, e_i) \psi_u^{-1} \Big\}_u^3$. We use (13.58)-(13.62). We claim that no term in (13.62) contributes to the limit. In effect $0\nabla^{TX}$ preserves the splitting $TX = TX^1 \oplus TX^2$. Then by (13.19), it is clear that $\left[0\nabla\pi_{\check{V}}^*\Lambda(T_{\mathbf{R}}^*S)\widehat{\otimes}\Lambda(T^{*(0,1)}X), 2\nabla\pi_{\check{V}}^*\Lambda(T_{\mathbf{R}}^*S)\widehat{\otimes}\Lambda(T^{*(0,1)}X) - 3\nabla\pi_{\check{V}}^*\Lambda(T_{\mathbf{R}}^*S)\widehat{\otimes}\Lambda(T^{*(0,1)}X) \right]$ does not contribute to the limit. Using the second identity in (1.35) and (7.27), we find that the remaining terms in (13.62) do not contribute to the above limit.

By Proposition 11.8, (11.61)-(11.65) and (13.58)-(13.61), we see that as $u \rightarrow 0$,

$$(13.63) \quad \left\{ u^2 \psi_u^3 \nabla_{y_0}^{\pi \nabla^* \Lambda(T_{\mathbf{R}}^* S) \widehat{\otimes} \Lambda(T^{*(0,1)} X), 2} (Z, e_i) \psi_u^{-1} \right\}_u^3 \rightarrow \langle i^*(\nabla^{TX})_{y_0}^2 Z, e_i \rangle - \langle A_{y_0}^2 P^{TY} Z, P^{TY} e_i \rangle .$$

From (13.24), (13.26), (13.40), (13.55)-(13.57), (13.63), we see that as $u \rightarrow 0$, the operator $\mathcal{M}_{u,T}^{3,y_0}$ converges to an operator $\mathcal{M}_{0,T}^{3,y_0}$ given by the formula

$$(13.64) \quad \begin{aligned} \mathcal{M}_{0,T}^{3,y_0} = & -\frac{1}{2} \sum_1^{2\ell} \left(\sqrt{T} \nabla_{P^{N_{Y/X}} e_i} + \nabla_{P^{TY} e_i} \right. \\ & \left. + \frac{1}{2} \left\langle (i^*(\nabla^{TX})_{y_0}^2 - P^{TY} A_{y_0}^2 P^{TY}) \left(P^{TY} Z + \frac{P^{N_{Y/X}} Z}{\sqrt{T}} \right), e_i \right\rangle \right. \\ & \left. + \frac{1}{2} \left\langle i^*(\nabla^{TX})_{y_0}^2 \frac{P^{N_{Y/X}} Z}{\sqrt{T}}, P^{TY} e_i \right\rangle - \frac{1}{2} \langle i^*(\nabla^{TX})_{y_0}^2 P^{TY} Z, P^{N_{Y/X}} e_i \rangle \right. \\ & \left. - \frac{c(A P^{TY} e_i)}{\sqrt{2}} \right)^2 + i^* \left((\nabla^\xi)^2 + \frac{1}{2} \text{Tr} [(\nabla^{TX})^2] \right)_{y_0} . \end{aligned}$$

Also using (13.51), (13.52), we find that as $u \rightarrow 0$,

$$(13.65) \quad \begin{aligned} & \left\{ \frac{1}{u} f^\alpha \nabla_{f_\alpha^{H,W}}^\xi V + \sum_1^{2\ell} \frac{c({}^0 \tau e_i)}{\sqrt{2}} \nabla_{0 \tau e_i}^\xi V \right\}_u^3 \left(u P^{TY} Z + \frac{u}{\sqrt{T}} P^{N_{Y/X}} Z \right) \\ & = \frac{1}{u} i^* \nabla^\xi V(y_0) - f^\alpha \nabla_{T_{y_0}^W(f_\alpha^{H,W}, P^{TY} Z)}^\xi V + \sum_{2\ell'+1}^{2\ell} \frac{c(e_i)}{\sqrt{2}} \nabla_{e_i}^\xi V(y_0) \\ & \quad + f^\alpha \widetilde{\nabla}_{P^{TY} Z + \frac{P^{N_{Y/X}} Z}{\sqrt{T}}}^\xi \nabla_{f_\alpha^{H,W}}^\xi V(y_0) \\ & \quad + \sum_{2\ell'+1}^{2\ell'} e^i \wedge \widetilde{\nabla}_{P^{TY} Z + \frac{P^{N_{Y/X}} Z}{\sqrt{T}}}^\xi \nabla_{0 \tau e_i}^\xi V(y_0) \\ & \quad + \mathcal{O} \left(u (|P^{TY} Z|^2 + \frac{|P^{N_{Y/X}} Z|^2}{T}) \right) . \end{aligned}$$

Now by [19, eq. (13.102)], by (7.21) and by Theorems 9.8 and 12.7,

$$\begin{aligned}
 & P^{\xi^-} f^\alpha \nabla_{T_{y_0}^W(f_\alpha^{H,W}, P^{TYZ})} V(y_0) P^{\xi^-} = 0 \\
 & P^{\xi^-} \sum_{2\ell'+1}^{2\ell} \frac{c(e_i)}{\sqrt{2}} \nabla_{e_i}^\xi V(y_0) P^{\xi^-} = S_{y_0}, \\
 & P^{\xi^-} f^\alpha \tilde{\nabla}_{P^{TYZ} + \frac{P^{N_{Y/X}}}{\sqrt{T}}} \nabla_{f_\alpha^{H,W}}^\xi V(y_0) P^{\xi^-} = 0, \\
 & P^{\xi^-} \sum_1^{2\ell'} e^i \wedge \tilde{\nabla}_{P^{TYZ} + \frac{P^{N_{Y/X}}}{\sqrt{T}}} \nabla_{e_i}^\xi V(y_0) P^{\xi^-} = 0.
 \end{aligned}
 \tag{13.66}$$

Identity (13.64) now plays the role of identity (12.15). Identity (13.65) replaces (12.21), and the identities (13.66) replace (12.22).

For $u > 0$, let \mathfrak{D}_u^2 be the operator defined in Theorem 5.8, which is associated to the exact sequence of holomorphic Hermitian vector bundles on W , $0 \rightarrow TY \rightarrow TX|_W \rightarrow N_{Y/X} \rightarrow 0$. Using the previous formulas, the second identity in (5.16) and proceeding as in [19, Section 13 i)], we find that given $T > 0$,

$$\begin{aligned}
 (13.67) \quad \lim_{u \rightarrow 0} \Phi \operatorname{Tr}_s \left[N_{\mathbf{H}} \exp(-A_{u,T/u}^2) \right] = \\
 \int_Y \Phi \operatorname{Tr}_s \left[N_{\mathbf{H}} \exp(-G_{1,T}^{-1} \mathfrak{D}_{T^2}^2 G_{1,T}) \right] \operatorname{ch}(\eta, g^\eta).
 \end{aligned}$$

Equivalently

$$(13.68) \quad \lim_{u \rightarrow 0} \Phi \operatorname{Tr}_s \left[N_{\mathbf{H}} \exp(-A_{u,T/u}^2) \right] = \int_Y \Phi \operatorname{Tr}_s \left[N_{\mathbf{H}} \exp(-\mathfrak{D}_{T^2}^2) \right] \operatorname{ch}(\eta, g^\eta).$$

Identity (13.68) is compatible with Theorem 6.8, because of (5.19).

13.8 The matrix structure of the operator $\mathcal{L}_{u,T}^{3,y_0}$ as $T \rightarrow +\infty$

For convenience, we introduce a Hermitian metric g^{TS} on TS . This metric induces a corresponding metric on $\Lambda(T_{\mathbf{R}}^*S)$.

Definition 13.12. Let \mathbf{F}_{y_0} (resp. $\mathbf{F}_{y_0}^0$) be the vector spaces of smooth (resp. square integrable) sections of $(\pi_W^* \Lambda(T_{\mathbf{R}}^*S) \hat{\otimes} \Lambda(T_{\mathbf{R}}^*Y) \otimes \eta)_{y_0}$ over $(T_{\mathbf{R}}Y)_{y_0}$. Let $\mathbf{K}_{y_0}^0, \mathbf{K}_{y_0}^{\pm,0}$ be the vector spaces of square integrable sections of $(\pi_W^* \Lambda(T_{\mathbf{R}}^*S) \hat{\otimes} \Lambda(T_{\mathbf{R}}^*Y) \hat{\otimes} \Lambda(\overline{N}_{Y/X}^*) \otimes \xi)_{y_0}, (\pi_W^* \Lambda(T_{\mathbf{R}}^*S) \hat{\otimes} \Lambda(T_{\mathbf{R}}^*Y) \hat{\otimes} \Lambda(N_{Y/X}^*) \hat{\otimes} \xi^\pm)_{y_0}$ over $(T_{\mathbf{R}}X)_{y_0}$.

We equip $\mathbf{F}_{y_0}^0$ with the Hermitian product

$$(13.69) \quad \sigma, \sigma' \in \mathbf{F}^0 \rightarrow \langle \sigma, \sigma' \rangle = \int_{(T_{\mathbf{R}}Y)_{y_0}} \langle \sigma, \sigma' \rangle (Z) \frac{dv_{TY}(Z)}{(2\pi)^{\dim Y}}.$$

We equip $\mathbf{K}_{y_0}^0$ with the Hermitian product

$$(13.70) \quad s, s' \in \mathbf{K}_{y_0}^0 \rightarrow \langle s, s' \rangle = \int_{(T_{\mathbf{R}X})_{y_0}} \langle s, s' \rangle (Z) \frac{dv_{T_X}(Z)}{(2\pi)^{\dim X}} .$$

We now use the notation of Chapters 7 and 8. In particular θ_{y_0} denotes the Kähler form of the fiber $N_{Y/X, \mathbf{R}, y_0}$. Set for $Z \in (T_{\mathbf{R}X})_{y_0}$,

$$(13.71) \quad \beta_{y_0}(Z) = \exp \left(\theta_{y_0} - \frac{|P^{N_{Y/X}} Z|^2}{2} \right) .$$

Here $\beta_{y_0}(Z)$ is considered as a section of $\left(\Lambda(\overline{N}_{Y/X}^* \widehat{\otimes} \Lambda(N_{Y/X}^*)) \right)_{y_0}$. Recall that $\xi_{y_0}^- = (\Lambda N_{Y/X}^* \otimes \eta)_{y_0}$.

Definition 13.13. Let ψ be the linear map $\psi : \sigma \in \mathbf{F}^0 \rightarrow \sigma \beta_{y_0} \in \mathbf{K}_{y_0}^0$.

Let $\mathbf{K}_{y_0}^{\prime 0}$ be the image of $\mathbf{F}_{y_0}^0$ in $\mathbf{K}_{y_0}^{-,0}$. By [19, Theorem 7.4], or by (8.41), ψ is an isometry from $\mathbf{F}_{y_0}^0$ onto $\mathbf{K}_{y_0}^{\prime 0}$.

Let $\mathbf{K}_{y_0}^{\prime 0, \perp}$, $\mathbf{K}_{y_0}^{\prime 0, \perp, -}$ be the orthogonal vector spaces to $\mathbf{K}_{y_0}^{\prime 0}$ in $\mathbf{K}_{y_0}^0$, $\mathbf{K}_{y_0}^{-,0}$ respectively. We then have the orthogonal splittings

$$(13.72) \quad \begin{aligned} \mathbf{K}_{y_0}^0 &= \mathbf{K}_{y_0}^{\prime 0} \oplus \mathbf{K}_{y_0}^{\prime 0, \perp} \\ \mathbf{K}_{y_0}^{-,0} &= \mathbf{K}_{y_0}^{\prime 0} \oplus \mathbf{K}_{y_0}^{\prime 0, \perp, -} . \end{aligned}$$

Let p, p^\perp denote the orthogonal projection operators from $\mathbf{K}_{y_0}^0$ on $\mathbf{K}_{y_0}^{\prime 0}$, $\mathbf{K}_{y_0}^{\prime 0, \perp}$ with respect to the Hermitian product (13.70).

Set

$$(13.73)$$

$$\begin{aligned} A_{u,T} &= p \mathcal{L}_{u,T}^{3,y_0} p, & B_{u,T} &= p \mathcal{L}_{u,T}^{3,y_0} p^\perp P^{\xi^-}, & C_{u,T} &= p \mathcal{L}_{u,T}^{3,y_0} P^{\xi^+}, \\ D_{u,T} &= P^{\xi^-} p^\perp \mathcal{L}_{u,T}^{3,y_0} p, & E_{u,T} &= P^{\xi^-} p^\perp \mathcal{L}_{u,T}^{3,y_0} p^\perp P^{\xi^-}, & F_{u,T} &= P^{\xi^-} p^\perp \mathcal{L}_{u,T}^{3,y_0} P^{\xi^+}, \\ G_{u,T} &= P^{\xi^+} \mathcal{L}_{u,T}^{3,y_0} p, & H_{u,T} &= P^{\xi^+} \mathcal{L}_{u,T}^{3,y_0} p^\perp P^{\xi^-}, & I_{u,T} &= P^{\xi^+} \mathcal{L}_{u,T}^{3,y_0} P^{\xi^+}. \end{aligned}$$

Then we write the operator $\mathcal{L}_{u,T}^{3,y_0}$ as a (3, 3) matrix with respect to the splitting $\mathbf{K}_{y_0}^0 = \mathbf{K}_{y_0}^{\prime 0} \oplus \mathbf{K}_{y_0}^{\prime 0, \perp, -} \oplus \mathbf{K}_{y_0}^{+,0}$,

$$(13.74) \quad \mathcal{L}_{u,T}^{3,y_0} = \begin{bmatrix} A_{u,T} & B_{u,T} & C_{u,T} \\ D_{u,T} & E_{u,T} & F_{u,T} \\ G_{u,T} & H_{u,T} & I_{u,T} \end{bmatrix} .$$

By proceeding as in Section 8.2, we know that for $u \in]0, 1]$, as $T \rightarrow +\infty$, the differential operator $\mathcal{L}_{u,T}^{3,y_0}$ has an asymptotic expansion of the form

$$(13.75) \quad \mathcal{L}_{u,T}^{3,y_0} = \sum_{k \leq 4} \mathcal{O}_{u,k} T^{k/2} .$$

Therefore as $T \rightarrow +\infty$, the operators $A_{u,T}, B_{u,T}, \dots$ have asymptotic expansions similar to (13.75). Put

$$(13.76) \quad \nu = \frac{1}{2 \dim Y} \sum_1^{2\ell'} A(e_i) e_i.$$

Then $\nu \in N_{Y/X, \mathbf{R}}$ is the mean curvature of Y in X .

We now prove one of the central results of this Section.

Theorem 13.14 — *For $u \in]0, 1]$, there exist operators $A_u, B_u, C_u, D_u, E, F_u, G_u, H_u, I_u$ such that as $T \rightarrow +\infty$,*

$$(13.77) \quad \begin{aligned} A_{u,T} &= A_u + \mathcal{O}\left(\frac{1}{\sqrt{T}}\right), & B_{u,T} &= \sqrt{T} B_u + \mathcal{O}(1), & C_{u,T} &= T C_u + \mathcal{O}(\sqrt{T}), \\ D_{u,T} &= \sqrt{T} D_u + \mathcal{O}(1), & E_{u,T} &= T E + \mathcal{O}(\sqrt{T}), & F_{u,T} &= T F_u + \mathcal{O}(\sqrt{T}), \\ G_{u,T} &= T G_u + \mathcal{O}(\sqrt{T}), & H_{u,T} &= T H_u + \mathcal{O}(\sqrt{T}), & I_{u,T} &= T^2 I_u + \mathcal{O}(T^{3/2}). \end{aligned}$$

Let \mathcal{P}_u be the operator acting on \mathbf{K}_{y_0}

$$(13.78) \quad \begin{aligned} \mathcal{P}_u &= u P^{\xi^-} \left\{ \varphi^2(u P^{TY} Z) \nabla_{\dim Y \nu(u P^{TY} Z)} + \sum_{2\ell'+1}^{2\ell} \frac{c(e_i)}{\sqrt{2}} \tilde{\nabla}_{P^{NY/Z} Z}^{\xi} \right. \\ &\quad \left. \left(\varphi^2 \nabla_{0_\tau e_i}^{\xi} V \right) (u P^{TY} Z) \right. \\ &\quad \left. + \frac{1}{2} \left[\tilde{\nabla}_{P^{NY/X} Z}^{\xi} (\varphi V^-)(u P^{TY} Z), \tilde{\nabla}_{P^{NY/X} Z}^{\xi} \tilde{\nabla}_{P^{NY/X} Z}^{\xi} (\varphi V^-)(u P^{TY} Z) \right] \right. \\ &\quad \left. - (\nabla_{P^{NY/X} Z} \varphi^2)(u P^{TY} Z) \left(S + \frac{|P^{NY/X} Z|^2}{2} \right) \right\} P^{\xi^-}. \end{aligned}$$

Then the following identities hold

$$(13.79) \quad \begin{aligned} B_u &= p \mathcal{P}_u p^\perp P^{\xi^-}; \\ C_u &= p P^{\xi^-} \varphi^2(u P^{TY} Z) \left(\frac{1}{u} \sum_1^{2\ell'} \left\{ \frac{uc(0_\tau e_i)}{\sqrt{2}} \right\}_u \left(\nabla_{0_\tau e_i}^{\xi} V \right) (u P^{TY} Z) \right. \\ &\quad \left. + \frac{1}{u} f^\alpha(\nabla_{f_a^{H,W}}^{\xi} V)(u P^{TY} Z) + \sum_{2\ell'+1}^{2\ell} \frac{c(e_i)}{\sqrt{2}} \left(\nabla_{0_\tau e_i}^{\xi} V \right) (u P^{TY} Z) \right) P^{\xi^+}, \\ D_u &= P^{\xi^-} p^\perp \mathcal{P}_u p, \\ E &= p^\perp P^{\xi^-} \left(-\frac{1}{2} \Delta^{NY/X} + \frac{1}{2} |P^{NY/X} Z|^2 + S \right) P^{\xi^-} p^\perp, \end{aligned}$$

$$\begin{aligned}
 G_u &= P^{\xi^+} \varphi^2(u P^{TY} Z) \left(\frac{1}{u} \sum_1^{2\ell'} \left\{ \frac{uc(0\tau e_i)}{\sqrt{2}} \right\}_u^3 \left(\nabla_{0\tau e_i}^\xi V \right) (u P^{TY} Z) \right. \\
 &\quad \left. + \frac{1}{u} f^\alpha \left(\nabla_{f_\alpha^{H,W}}^\xi V \right) (u P^{TY} Z) + \sum_{2\ell'+1}^{2\ell} \frac{c(e_i)}{\sqrt{2}} \left(\nabla_{0\tau e_i}^\xi V \right) (u P^{TY} Z) \right) p, \\
 I_u &= \frac{1}{u^2} P^{\xi^+} \left((\varphi V^+)^2 + (1 - \varphi^2) P^{\xi^+} \right) (u P^{TY} Z) P^{\xi^+}.
 \end{aligned}$$

Proof. Using formulas (13.15), (13.25), (13.39)-(13.42), the proof of our Theorem is the same as the proof of [19, Theorem 13.22]. □

13.9 The asymptotics of $F_T k^{1/2} \tilde{A}_{1,T} k^{-1/2} F_T^{-1}$

We use temporarily the same notation as in Section 8.1.

Take $x = (y, Z) \in \mathcal{U}_{\varepsilon_0}$. We identify ξ_x to ξ_y in the same way as in Section 8.1. Also we identify $(\pi_V^* \Lambda(T_{\mathbf{R}}^* S) \hat{\otimes} \Lambda(T^{*(0,1)} X))_x$ to $(\pi_V^* \Lambda(T_{\mathbf{R}}^* S) \hat{\otimes} \Lambda(T^{*(0,1)} X))_y$ by parallel transport with respect to the connection ${}^3\nabla_{y_0}^{\pi_V^* \Lambda(T_{\mathbf{R}}^* S) \hat{\otimes} \Lambda(T^{*(0,1)} X)}$ along the geodesic in X , $t \in [0, 1] \rightarrow (y, tZ)$.

Then the restriction of $\tilde{A}_{1,T}$ to $\mathcal{U}_{\varepsilon_0}$ acts naturally on smooth sections of $\Lambda(T_{\mathbf{R}}^* S) \hat{\otimes} \mathbf{E}(\varepsilon_0)$, and so it defines a superconnection on $\mathbf{E}(\varepsilon_0 \sqrt{T})$.

Definition 13.15. Let \mathfrak{C} be the superconnection on \mathbf{E} ,

$$\begin{aligned}
 (13.80) \quad \mathfrak{C} &= D^H + \sum_1^{2\ell} \frac{c(e_i)}{\sqrt{2}} B_y(e_i) + \frac{1}{2} \tilde{\nabla}_Z^\xi \tilde{\nabla}_Z^\xi V(y) \\
 &\quad + f^\alpha \wedge \left({}^0\tilde{\nabla}_{(f_\alpha^{H,W})^H} \Lambda(T^{*(0,1)} X) \hat{\otimes} \xi + B_y(f_\alpha^{H,W}) \right) \\
 &\quad - \frac{1}{2} f^\alpha f^\beta \frac{c(T^W(f_\alpha^{H,W}, f_\beta^{H,W}))}{2\sqrt{2}}.
 \end{aligned}$$

Now we give another version of Theorem 8.5. Of course the difference is that we have used a different trivialization of $\pi_V^* \Lambda(T_{\mathbf{R}}^* S) \hat{\otimes} \Lambda(T^{*(0,1)} X)$. In what follows, $Z \in N_{Y/X, \mathbf{R}}$

Theorem 13.16 — *As $T \rightarrow +\infty$, then*

$$\begin{aligned}
 (13.81) \quad F_T k^{1/2} \tilde{A}_{1,T} k^{-1/2} F_T^{-1} &= TV^+(y) + \sqrt{T} (D^{N_{Y/X}} + \tilde{\nabla}_Z^\xi V(y)) \\
 &\quad + \mathfrak{C} + \frac{1}{\sqrt{T}} \mathfrak{O} \left(|Z|^2 \partial^{N_{Y/X}} + |Z| \partial^Y + |Z| \partial^S + |Z| + |Z|^3 \right).
 \end{aligned}$$

Proof. Inspection of the proof of Theorem 8.5 shows that the only term in $F_T k^{1/2} \tilde{A}_{1,T} k^{-1/2} F_T^{-1}$ which may eventually modify the expansion in (8.10) is $F_T k^{1/2} D^X k^{-1/2} F_T^{-1}$.

Clearly

$$(13.82) \quad D^X = \sum_1^{2\ell} \frac{c^{(0)} \tau e_i}{\sqrt{2}} \nabla_{0\tau e_i} \Lambda(T^{*(0,1)} X) \hat{\otimes} \xi.$$

□

Using (13.82), we find by a formal argument that with respect to [19, Theorem 8.18] or to (8.10), there is an extra contribution in the present expansion of $F_T k^{1/2} D^X k^{-1/2} F_T^{-1}$ given by

$$(13.83) \quad \sum_{2\ell'+1}^{2\ell} \left[\left({}^3 \nabla \pi_{\check{V}}^* \Lambda(T_{\mathbf{R}}^* S) \hat{\otimes} \Lambda(T^{*(0,1)} X) - {}^0 \nabla \pi_{\check{V}}^* \Lambda(T_{\mathbf{R}}^* S) \hat{\otimes} \Lambda(T^{*(0,1)} X) \right)_y (Z), \frac{c(e_i)}{\sqrt{2}} \right] \nabla_{e_i} \\ + \sum_{2\ell'+1}^{2\ell} \frac{c(e_i)}{\sqrt{2}} \left({}^0 \nabla \pi_{\check{V}}^* \Lambda(T_{\mathbf{R}}^* S) \hat{\otimes} \Lambda(T^{*(0,1)} X) - {}^3 \nabla \pi_{\check{V}}^* \Lambda(T_{\mathbf{R}}^* S) \hat{\otimes} \Lambda(T^{*(0,1)} X) \right)_y (e_i) = \\ \left[\left({}^3 \nabla \pi_{\check{V}}^* \Lambda(T_{\mathbf{R}}^* S) \hat{\otimes} \Lambda(T^{*(0,1)} X) - {}^0 \nabla \pi_{\check{V}}^* \Lambda(T_{\mathbf{R}}^* S) \hat{\otimes} \Lambda(T^{*(0,1)} X) \right) (Z), D^{N_{Y/X}} \right].$$

Now by (7.27), (13.15), (13.18), it is clear that for $2\ell' + 1 \leq i \leq 2\ell$,

$$(13.84) \quad \left[\left({}^3 \nabla \pi_{\check{V}}^* \Lambda(T_{\mathbf{R}}^* S) \hat{\otimes} \Lambda(T^{*(0,1)} X) - {}^0 \nabla \pi_{\check{V}}^* \Lambda(T_{\mathbf{R}}^* S) \hat{\otimes} \Lambda(T^{*(0,1)} X) \right)_y (Z), \frac{c(e_i)}{\sqrt{2}} \right] = 0.$$

Also by (13.18),

$$(13.85) \quad \sum_{2\ell'+1}^{2\ell} \frac{c(e_i)}{\sqrt{2}} \left({}^0 \nabla \pi_{\check{V}}^* \Lambda(T_{\mathbf{R}}^* S) \hat{\otimes} \Lambda(T^{*(0,1)} X) - {}^3 \nabla \pi_{\check{V}}^* \Lambda(T_{\mathbf{R}}^* S) \hat{\otimes} \Lambda(T^{*(0,1)} X) \right)_y (e_i) \\ = - \sum_{2\ell'+1}^{2\ell} \frac{c(e_i)}{\sqrt{2}} \left\langle \nabla_{e_i}^{TX} f_{\alpha}^{H, N_{Y/X}} + T^V (f_{\alpha}^{H, V}, e_i), e_j \right\rangle_y \frac{f^{\alpha} c(e_j)}{\sqrt{2}} \\ - \sum_{2\ell'+1}^{2\ell} \frac{c(e_i)}{2\sqrt{2}} \left(\left\langle S^V (e_i) f_{\alpha}^{H, W}, f_{\beta}^{H, W} \right\rangle - \left\langle f_{\alpha}^{H, N_{Y/X}}, \nabla_{e_i}^{TX} f_{\beta}^{H, N_{Y/X}} \right\rangle \right)_y f^{\alpha} f^{\beta}.$$

Using (7.27) again, the first expression in the right-hand side of (13.85) vanishes on W . Also by (1.6), (7.27), we get for $2\ell' + 1 \leq i \leq 2\ell$,

$$(13.86) \quad \left\langle f_{\alpha}^{H, N_{Y/X}}, \nabla_{e_i}^{TX} f_{\beta}^{H, N_{Y/X}} \right\rangle = - \left\langle f_{\alpha}^{H, N_{Y/X}}, T^V (f_{\beta}^{H, V}, e_i) \right\rangle \\ = - \left\langle T^V (f_{\beta}^{H, V}, f_{\alpha}^{H, N_{Y/X}}), e_i \right\rangle.$$

Moreover using (1.5), (1.6), we obtain

$$\begin{aligned}
 (13.87) \quad \langle S^V(e_i) f_\alpha^{H,W}, f_\beta^{H,W} \rangle &= \frac{1}{2} \langle T^V(f_\alpha^{H,W}, f_\beta^{H,W}), e_i \rangle \\
 &\quad + \frac{1}{2} \langle T^V(f_\alpha^{H,W}, e_i), f_\beta^{H,W} \rangle - \frac{1}{2} \langle T^V(f_\beta^{H,W}, e_i), f_\alpha^{H,W} \rangle \\
 &= \frac{1}{2} \langle T^V(f_\alpha^{H,W}, f_\beta^{H,W}), e_i \rangle + \frac{1}{2} \langle T^V(f_\alpha^{H,V}, e_i), f_\beta^{H,N_{Y/X}} \rangle \\
 &\quad - \frac{1}{2} \langle T^V(f_\beta^{H,V}, e_i), f_\alpha^{H,N_{Y/X}} \rangle \\
 &= \frac{1}{2} \langle T^V(f_\alpha^{H,W}, f_\beta^{H,W}) + T^V(f_\alpha^{H,V}, f_\beta^{H,N_{Y/X}}) - T^V(f_\beta^{H,V}, f_\alpha^{H,N_{Y/X}}), e_i \rangle.
 \end{aligned}$$

From (13.85)-(13.87), we find that

$$\begin{aligned}
 (13.88) \quad \sum_{2\ell'+1}^{2\ell} \frac{c(e_i)}{\sqrt{2}} \left({}^0\nabla \pi_{\check{V}}^* \Lambda(T_{\mathbb{R}^*S}^*) \widehat{\otimes} \Lambda(T^{*(0,1)}X) - {}^3\nabla \pi_{\check{V}}^* \Lambda(T_{\mathbb{R}^*S}^*) \widehat{\otimes} \Lambda(T^{*(0,1)}X) \right) (e_i) \\
 = -\frac{1}{2} f^\alpha f^\beta \frac{c(P^{N_{Y/X}} T^V(f_\alpha^{H,W}, f_\beta^{H,W}))}{2\sqrt{2}}.
 \end{aligned}$$

From (8.9), (8.10), (13.83), (13.84), (13.88), we get (13.81). The proof of our Theorem is completed. □

Theorem 13.17 — *The following identity holds*

$$(13.89) \quad \psi^{-1} p \mathfrak{C} p \psi = B_1^W.$$

Proof. The proof of our Theorem is the same as the proof of Theorem 8.8. Note that here, the identity (8.48) is not needed. □

Using [19, Proposition 8.9] and Theorem 13.16, we find that as $T \rightarrow +\infty$,

$$\begin{aligned}
 (13.90) \quad F_T \widetilde{A}_{1,T} F_T^{-1} &= TV^+(y) + \sqrt{T}(D^{N_{Y/X}} + \widetilde{\nabla}_Z^\xi V(y)) \\
 &\quad + \mathfrak{C} - \frac{\dim Y}{\sqrt{2}} c(\nu) + \mathfrak{O}\left(\frac{1}{\sqrt{T}}\right).
 \end{aligned}$$

Also

$$\begin{aligned}
 (13.91) \quad [D^H, D^{N_{Y/X}}] &= 0 \\
 \left[f^\alpha \wedge {}^0\nabla_{(f_\alpha^{H,W})_H} \Lambda(T^{*(0,1)}X) \widehat{\otimes} \xi, D^{N_{Y/X}} \right] &= 0.
 \end{aligned}$$

By squaring (13.90), using (13.91) and comparing with (13.77), one gets an explanation for the simplicity of formula (13.78) for \mathcal{P}_u .

13.10 A family of Sobolev spaces with weights

Let q be the orthogonal projection operator from $(\pi_W^* \Lambda(T_{\mathbf{R}}^* S) \widehat{\otimes} \Lambda(T_{\mathbf{R}}^* Y) \widehat{\otimes} \Lambda(\overline{N}_{Y/X}^*) \otimes \xi)_{y_0}$ on $(\pi_W^* \Lambda(T_{\mathbf{R}}^* S) \widehat{\otimes} \Lambda(T_{\mathbf{R}}^* Y) \widehat{\otimes} \{\exp(\theta)\} \widehat{\otimes} \eta)_{y_0}$. Recall that p is the orthogonal projection operator from $\mathbf{K}_{y_0}^0$ on \mathbf{K}'_{y_0} and that $p^\perp = 1 - p$. By an obvious analogue of (8.43), we know that if $s \in \mathbf{K}'_{y_0}$,

$$(13.92) \quad ps(Z) = \frac{1}{\pi^{\dim N_{Y/X}}} \exp\left(\frac{-|P^{N_{Y/X}} Z|^2}{2}\right) \int_{N_{Y/X, \mathbf{R}, y_0}} \exp\left(\frac{-|Z'|^2}{2}\right) s(P^{TY} Z + Z') dv_{N_{Y/X}}(Z').$$

Let ψ^* be the adjoint of the map $\psi : \mathbf{F}_0^0 \rightarrow \mathbf{K}'_{y_0}$ defined in Definition 13.13 with respect to the Hermitian product (13.69), (13.70). Then

$$(13.93) \quad \psi^* = \psi^{-1} p.$$

Definition 13.18. If $Z \in (T_{\mathbf{R}} X)_{y_0}$, $U \in (T_{\mathbf{R}} Y)_{y_0}$, set

$$(13.94) \quad \begin{aligned} g_{u,T}(Z) &= 1 + \left(1 + |P^{TY} Z|^2\right)^{1/2} \varphi\left(\frac{1}{2} u P^{TY} Z\right) \\ &\quad + \left(1 + \frac{|P^{N_{Y/X}} Z|^2}{T}\right)^{1/2} \varphi\left(\frac{u}{2\sqrt{T}} |P^{N_{Y/X}} Z|\right), \\ \tilde{g}_u(U) &= 1 + \left(1 + |U|^2\right)^{1/2} \varphi\left(\frac{uU}{2}\right). \end{aligned}$$

The algebra $(\pi_W^* \Lambda(T_{\mathbf{R}}^* S) \widehat{\otimes} \Lambda(T_{\mathbf{R}}^* Y))_{y_0}$ splits into

$$(13.95) \quad (\pi_W^* \Lambda(T_{\mathbf{R}}^* S) \widehat{\otimes} \Lambda(T_{\mathbf{R}}^* Y))_{y_0} = \bigoplus_0^{2(\dim Y + \dim S)} (\pi_W^* \Lambda(T_{\mathbf{R}}^* S) \widehat{\otimes} \Lambda(T_{\mathbf{R}}^* Y))_{y_0}^r.$$

This splitting induces corresponding splittings

$$(13.96) \quad \begin{aligned} \mathbf{K}_{y_0}^0 &= \bigoplus_0^{2(\dim Y + \dim S)} \mathbf{K}_{r, y_0}^0, \\ \mathbf{F}_{y_0}^0 &= \bigoplus_0^{2(\dim Y + \dim S)} \mathbf{F}_{r, y_0}^0. \end{aligned}$$

Definition 13.19. If $s \in \mathbf{K}'_{r, y_0}$, set

$$(13.97) \quad |s|_{u, T, y_0, 0}^2 = \int_{(T_{\mathbf{R}} X)_{y_0}} |s|^2 [g_{u,T}]^{2(2 \dim Y + 2 \dim S - r)}(Z) dv_{TX}(Z).$$

Let $\langle \cdot, \cdot \rangle_{u,T,y_0,0}$ be the Hermitian product on $\mathbf{K}_{y_0}^0$ which is the direct sum of the Hermitian products on the \mathbf{K}_{r,y_0}^0 's associated with formula (13.97).

If $\mu \in \mathbf{R}$, let $\mathbf{K}_{y_0}^\mu, \mathbf{K}_{y_0}^{\pm,\mu}$ be the Sobolev spaces of order μ of sections of $\left(\pi_W^* \Lambda(T_{\mathbf{R}}^* S) \otimes \Lambda(T_{\mathbf{R}}^* Y) \widehat{\otimes} \Lambda(\overline{N}_{Y/X}^*) \widehat{\otimes} \xi \right)_{y_0}, \left(\pi_W^* \Lambda(T_{\mathbf{R}}^* S) \widehat{\otimes} \Lambda(T_{\mathbf{R}}^* Y) \widehat{\otimes} \Lambda(N_{Y/X}^*) \widehat{\otimes} \xi^\pm \right)_{y_0}$ over $(T_{\mathbf{R}} X)_{y_0}$. If $s \in \mathbf{K}_{y_0}^\mu$, we write $s = s^+ + s^-, s^\pm \in \mathbf{K}_{y_0}^{\pm,\mu}$.

Definition 13.20. If $s \in \mathbf{K}_{y_0}^1$, set

$$(13.98) \quad |s|_{u,T,y_0,1}^2 = \frac{T^2}{u^2} |s^+|_{u,T,y_0,0}^2 + T |p^\perp s^-|_{u,T,y_0,0}^2 + T \left| |P^{N_{Y/X}} Z| p^\perp s^- \right|_{u,T,y_0,0}^2 + |p s|_{u,T,y_0,0}^2 + \sum_1^{2\ell'} |\nabla_{e_i} s|_{u,T,y_0,0}^2 + T \sum_{2\ell'+1}^{2\ell} |\nabla_{e_i} p^\perp s|_{u,T,y_0,0}^2 .$$

Then (13.98) defines a Hilbert norm on $\mathbf{K}_{y_0}^1$. Let $\mathbf{K}_{y_0}^{-1}$ be the antidual of $\mathbf{K}_{y_0}^1$ and let $|\cdot|_{u,T,y_0,-1}$ be the norm on $\mathbf{K}_{y_0}^{-1}$ associated with the norm $|\cdot|_{u,T,y_0,1}$ on $\mathbf{K}_{y_0}^1$. We identify $\mathbf{K}_{y_0}^0$ with its antidual by the Hermitian product $\langle \cdot, \cdot \rangle_{u,T,y_0,0}$.

We have the family of continuous dense embeddings with uniformly bounded norms

$$(13.99) \quad \mathbf{K}_{y_0}^1 \rightarrow \mathbf{K}_{y_0}^0 \rightarrow \mathbf{K}_{y_0}^{-1} .$$

In view of Theorems 13.11 and 13.14, it should now be clear that the functional analytic arguments of [19, Sections 13 k)–13 o)] can be used without any change. In effect, the asymptotic structure of $\mathcal{L}_{u,T}^{3,y_0}$ as $T \rightarrow +\infty$ is exactly the same as in [19, Section 13]. Of course, we have the extra Grassmann variables f^α , but these are exactly of the same nature as the e^i ($1 \leq i \leq 2\ell'$).

Details are left to the reader.

13.11 The operator Ξ_{y_0}

Definition 13.21. For $u > 0, y_0 \in Y$, let $\Xi_{y_0}^{y_0}$ be the operator from \mathbf{F}_{y_0} into itself

$$(13.100) \quad \Xi_{y_0}^{y_0} = \psi^{-1} (A_u - B_u E^{-1} D_u - C_u I_u^{-1} G_u) \psi .$$

In view of (13.79), one verifies easily that $\Xi_{y_0}^{y_0}$ is a second order elliptic differential operator.

If $U \in B_{y_0}^{TY}(0, \varepsilon)$, we identify $(\pi_W^* \Lambda(T_{\mathbf{R}}^* S) \widehat{\otimes} \Lambda(T^{*(0,1)} Y))_U, \eta_U$ with $(\pi_W^* \Lambda(T_{\mathbf{R}}^* S) \widehat{\otimes} \Lambda(T^{*(0,1)} Y))_{y_0}, \eta_{y_0}$ by parallel transport with respect to ${}^1 \nabla^{\pi_W^* \Lambda(T_{\mathbf{R}}^* S) \widehat{\otimes} \Lambda(T^{*(0,1)} Y), u}$, ∇^n along the geodesic in Y $t \in [0, 1] \rightarrow tU$.

Let G_u be the linear map

$$(13.101) \quad h \in \mathbf{F}_{y_0} \rightarrow G_u h \in \mathbf{F}_{y_0} \quad , \quad G_u h(U) = h\left(\frac{U}{u}\right), U \in T_{\mathbf{R}}Y_{y_0}.$$

Let Σ_u^{2,y_0} be the operator acting on smooth sections, of $(\pi_W^* \Lambda(T_{\mathbf{R}}^* S) \widehat{\otimes} \Lambda(T^{*(0,1)} Y) \widehat{\otimes} \eta))_{y_0}$

$$(13.102) \quad \Sigma_u^{2,y_0} = G_u^{-1} B_{u^2}^{W,2} G_u.$$

Let Σ_u^{3,y_0} be the operator obtained from Σ_u^{2,y_0} by replacing the Clifford variable $c(e_i)$ ($1 \leq i \leq 2\ell'$) by $\frac{\sqrt{2}e^i \wedge}{u} - \frac{u^i e_i}{\sqrt{2}}$. Then Σ_u^{3,y_0} is a differential operator acting on smooth sections of $(\pi_W^* \Lambda(T_{\mathbf{R}}^* S) \widehat{\otimes} \Lambda(T_{\mathbf{R}}^* Y) \widehat{\otimes} \eta))_{y_0}$ over $B_{y_0}^{TY}(0, \varepsilon/u)$.

Now we prove the obvious extension of [19, Theorem 13.43].

Theorem 13.22 — *Over $B_{y_0}^{TY}(0, \varepsilon/2u)$, the following identity holds*

$$(13.103) \quad \Sigma_u^{3,y_0} = \Xi_u^{y_0}.$$

Proof. Using Theorem 13.17 and (13.90), the proof is formally exactly the same as the proof of [19, Theorem 13.43] and of Theorem 9.25. □

13.12 Proof of Theorem 13.2

Using Theorems 13.11, 13.14, 13.22, the proof of Theorem 13.2 proceeds as the proof of [19, Theorem 13.6] in [19, Section 13 q)]. □

13.13 A proof of Theorem 6.19

Now, we will establish (6.85). Namely we show that if $h_{u,T}$ is one of the fonctions $\theta_{u,T}, \lambda'_{u,T}, \lambda''_{u,T}, \pi'_{u,T}, \pi''_{u,T}$, then for $u \in]0, 1]$, $T \geq 1$,

$$(13.104) \quad |h_{u,T/u} - h_u^*| \leq \frac{C}{T^\delta}.$$

To make the discussion simpler, we will take $h_{u,T} = \theta_{u,T}$, the discussion for the other cases being much easier. Also the proof of (6.85) for $h_{u,T} = \eta_{u,T}$ (with $u \geq u_0 > 0$) is essentially similar.

An evaluation of the limit of $\theta_{u,T}$ as $T \rightarrow +\infty$

First we will show that for $u > 0$,

$$(13.105) \quad \lim_{T \rightarrow +\infty} \theta_{u,T} = \theta_u^*.$$

We will recall a few identities from [14, Theorems 1.7, 1.14 and 2.6], which are more precise than Theorem 2.14. Recall that $\omega^{V,H}$ was defined in (3.16).

Theorem 13.23 — *The following identities hold*

(13.106)

$$\begin{aligned} \nabla^{E'',2} &= 0, \nabla^{E',2} = 0, \\ [\nabla^{E''}, \bar{\partial}^X] &= 0, [\nabla^{E'}, \bar{\partial}^{X*}] = 0, \\ [\nabla^{E''}, \omega^{V,H}] &= 0, [\nabla^{E'}, \omega^{V,H}] = 0, \\ [\bar{\partial}^X, \omega^{V,H}] &= \frac{ic(T^{V(1,0)})}{\sqrt{2}}, [\bar{\partial}^{X*}, \omega^{V,H}] = \frac{-ic(T^{V(0,1)})}{\sqrt{2}}, \\ [\nabla^{E''}, c(T^{V(1,0)})] &= [\bar{\partial}^X, c(T^{V(1,0)})] = 0, [\nabla^{E'}, c(T^{V(0,1)})] = [\bar{\partial}^{X*}, c(T^{V(0,1)})] = 0. \end{aligned}$$

Proof. These results are proved in [14]. In particular the third identity was established in [14, Theorem 1.7 and eq. (2.21)]. Of course, the reader should keep in mind that $\bar{\partial}$ in [14] is $\sqrt{2}\bar{\partial}^X$. □

For $a \in \mathbf{C}^*, u > 0, T \geq 0$, set

$$\begin{aligned} A_{u,T}^{1''} &= au\bar{\partial}^X + Tv + \nabla^{E''} + d\bar{a} \left(\frac{\partial}{\partial \bar{a}} - \frac{i\omega^{V,H}}{2u^2 a \bar{a}^2} \right) - \frac{c(T^{V(1,0)})}{2\sqrt{2}u\bar{a}}, \\ (13.107) \quad A_{u,T}^{1'} &= \bar{a}u\bar{\partial}^{X*} + Tv^* + \nabla^{E'} + da \left(\frac{\partial}{\partial a} + \frac{i\omega^{V,H}}{2u^2 \bar{a} a^2} \right) - \frac{c(T^{V(0,1)})}{2\sqrt{2}ua}, \\ A_{u,T}^1 &= A_{u,T}^{1''} + A_{u,T}^{1'}. \end{aligned}$$

Then $A_{u,T}^1$ is a superconnection on E over $S \times \mathbf{C}^*$.

Proposition 13.24 — *The following identities hold,*

$$\begin{aligned} (13.108) \quad A_{u,T}^{1''} &= \exp\left(\frac{-i\omega^{V,H}}{2u^2|a|^2}\right) \left(a\bar{\partial}^X + Tv + \nabla^{E''} + d\bar{a} \frac{\partial}{\partial \bar{a}} \right) \exp\left(\frac{i\omega^{V,H}}{2u^2|a|^2}\right), \\ A_{u,T}^{1'} &= \exp\left(\frac{i\omega^{V,H}}{2u^2|a|^2}\right) \left(\bar{a}\bar{\partial}^{X*} + Tv^* + \nabla^{E'} + da \frac{\partial}{\partial a} \right) \exp\left(\frac{-i\omega^{V,H}}{2u^2|a|^2}\right). \end{aligned}$$

Proof. This identity immediately follows from (13.106). □

Theorem 13.25 — *The following identities hold,*

$$\begin{aligned} (13.109) \quad A_{u,T}^{1'',2} &= 0, A_{u,T}^{1',2} = 0, \\ A_{u,T|_{a=1}}^{1,2} &= A_{u,T}^2 + dau \frac{\partial}{\partial u} A_{u,T}'' + d\bar{a}u \frac{\partial}{\partial u} A_{u,T}' + dad\bar{a} \frac{i\omega^{V,H}}{u^2}. \end{aligned}$$

Proof. By Theorem 13.23,

$$\begin{aligned} (13.110) \quad \left(a\bar{\partial}^X + Tv + \nabla^{E''} + d\bar{a} \frac{\partial}{\partial \bar{a}} \right)^2 &= 0, \\ \left(\bar{a}\bar{\partial}^{X*} + Tv^* + \nabla^{E'} + da \frac{\partial}{\partial a} \right)^2 &= 0. \end{aligned}$$

From (13.108), (13.110), we get the first two identities in (13.109). Then,

$$(13.111) \quad A_{u,T}^{1,2} = \left[A_{u,T}^{1''}, A_{u,T}^{1'} \right].$$

By (13.107), (13.110), (13.111) we get

$$(13.112) \quad \begin{aligned} A_{u,T|_{a=1}}^{1,2} &= A_{u,T}^2 + da \left(u\bar{\partial}^X - \frac{[\bar{\partial}^X, i\omega^{V,H}]}{2u} \right) \\ &+ d\bar{a} \left(u\bar{\partial}^{X*} + \frac{[\bar{\partial}^{X*}, i\omega^{V,H}]}{2u} \right) + dad\bar{a} \frac{i\omega^{V,H}}{u^2}. \end{aligned}$$

Using Theorem 13.23 and (13.112), we obtain

$$(13.113) \quad \begin{aligned} A_{u,T|_{a=1}}^{1,2} &= A_{u,T}^2 + da \left(u\bar{\partial}^X + \frac{c(T^{V(1,0)})}{2\sqrt{2}u} \right) \\ &+ d\bar{a} \left(u\bar{\partial}^{X*} + \frac{c(T^{V(1,0)})}{2\sqrt{2}u} \right) + dad\bar{a} \frac{i\omega^{V,H}}{u^2}, \end{aligned}$$

which is exactly the last identity in (13.109). The proof of our Theorem is completed. □

Remark 13.26. It should be pointed out that the identities in (13.109) are not special cases of (13.106). In fact there are associated with the fibrations $V \times \mathbf{C}^* \rightarrow S \times \mathbf{C}^*$, and $V \times \mathbf{C}^*$ is equipped with the (1, 1) form $\frac{1}{|a|^2}\omega^V$, which is not closed over $V \times \mathbf{C}^*$.

By Theorem 13.25, it is clear that

$$(13.114) \quad \theta_{u,T} = -\text{Tr}_S \left[N_{\mathbf{H}} \exp \left(-A_{\sqrt{u},\sqrt{T}|_{a=1}}^{1,2} + dad\bar{a}N_u^V \right) \right]^{dad\bar{a}}.$$

To study $\theta_{u,T}$ as $T \rightarrow +\infty$, we will proceed as in Chapters 8-9. However the situation is subtler, because the holomorphic and antiholomorphic directions in V have now been made in some sense independent.

Let f_1, \dots, f_m be a locally defined smooth basis of $T_{\mathbf{R}}S$. Similarly, g_1, \dots, g_m denotes a locally defined smooth basis of TS , $\bar{g}_1, \dots, \bar{g}_m$ the corresponding conjugate basis of \overline{TS} . Of course f^1, \dots, f^{2m} (resp. g^1, \dots, g^m , resp. $\bar{g}^1, \dots, \bar{g}^m$) denote the dual basis of $T_{\mathbf{R}}^*S$ (resp. T^*S , resp. $\overline{T^*S}$).

Instead of Definition 7.16, we now define.

Definition 13.27. Set

$$\begin{aligned}
 \tilde{A}_{u,T}^{1''} &= \exp \left\{ -\frac{g^\alpha c(g_\alpha^{H,N_{Y/X}})}{u\bar{a}} - \frac{\bar{g}^\alpha c(\bar{g}_\alpha^{H,N_{Y/X}})}{ua} \frac{1}{\sqrt{2}} \right\} \\
 A_{u,T}^{1''} &\exp \left\{ \frac{g^\alpha c(g_\alpha^{H,N_{Y/X}})}{u\bar{a}} + \frac{\bar{g}^\alpha c(\bar{g}_\alpha^{H,N_{Y/X}})}{ua} \frac{1}{\sqrt{2}} \right\}, \\
 \tilde{A}_{u,T}^{1'} &= \exp \left\{ -\frac{g^\alpha c(g_\alpha^{H,N_{Y/X}})}{u\bar{a}} - \frac{\bar{g}^\alpha c(\bar{g}_\alpha^{H,N_{Y/X}})}{ua} \frac{1}{\sqrt{2}} \right\} \\
 A_{u,T}^{1'} &\exp \left\{ \frac{g^\alpha c(g_\alpha^{H,N_{Y/X}})}{u\bar{a}} + \frac{\bar{g}^\alpha c(\bar{g}_\alpha^{H,N_{Y/X}})}{ua} \frac{1}{\sqrt{2}} \right\}, \\
 \tilde{A}_{u,T}^1 &= \tilde{A}_{u,T}^{1'} + \tilde{A}_{u,T}^{1''}.
 \end{aligned}
 \tag{13.115}$$

Clearly, $\tilde{A}_{u,T}^1$ is a superconnection on E over $S \times \mathbf{C}^*$, which is conjugate to $A_{u,T}^1$. Now we will give a formula for $\tilde{A}_{u,T}^{1''}$, which extends Theorem 7.17.

As in (7.36), we will assume that

$$\begin{aligned}
 [f_\alpha, f_\beta] &= 0, \\
 [g_\alpha, g_\beta] &= 0, [g_\alpha, \bar{g}_\beta] = 0.
 \end{aligned}
 \tag{13.116}$$

Let w_1, \dots, w_ℓ be an orthonormal basis of TX , let w^1, \dots, w^ℓ be the corresponding dual basis of T^*X .

Theorem 13.28 — *The following identity holds*

$$\begin{aligned}
 \tilde{A}_{1,T}^{1''} &= a\bar{\partial}^X + Tv + \bar{g}^\alpha \wedge \left(\nabla_{\frac{H}{g_\alpha}}^{\Lambda(T^{*(0,1)}X)} \otimes \xi - \frac{1}{2}c(w_i)c \left(\nabla_{\bar{w}_i}^{TX} \bar{g}_\alpha^{H,N_{Y/X}} \right) \right) - \\
 &\quad - \frac{a}{\bar{a}} g^\alpha \frac{1}{2} c(w_i) c \left(\nabla_{\bar{w}_i}^{TX} g_\alpha^{H,N_{Y/X}} \right) + \\
 &\quad d\bar{a} \left(\frac{\partial}{\partial \bar{a}} - \frac{\bar{g}^\alpha c(\bar{g}_\alpha^{H,N_{Y/X}})}{\bar{a}^2} \frac{1}{\sqrt{2}} - \frac{i}{2} \frac{g^\alpha \bar{g}^\beta}{a\bar{a}^2} \omega^V(g_\alpha^{H,W}, \bar{g}_\beta^{H,W}) \right) - \\
 &\quad - \frac{g^\alpha \bar{g}^\beta}{\bar{a}} \left[\frac{1}{2} \langle T^V(g_\alpha^{H,V}, \bar{g}_\beta^{H,W}), \bar{w}_i \rangle + \right. \\
 &\quad \left. + \frac{1}{2} \left(\langle g_\alpha^{H,N_{Y/X}}, \nabla_{\bar{w}_i}^{TX} \bar{g}_\beta^{H,N_{Y/X}} \rangle - \langle \bar{g}_\beta^{H,N_{Y/X}}, \nabla_{\bar{w}_i}^{TX} g_\alpha^{H,N_{Y/X}} \rangle \right) \right] \\
 &\quad + \left\langle \nabla_{\frac{H}{g_\beta}}^{TX} g_\alpha^{H,N_{Y/X}}, \bar{w}_i \right\rangle \left[\frac{c(w_i)}{\sqrt{2}} + \frac{\bar{g}^\alpha \bar{g}^\beta}{a} \frac{c}{\sqrt{2}} \left(\nabla_{\frac{H}{g_\alpha}}^{TX} \bar{g}_\beta^{H,N_{Y/X}} \right) \right. \\
 &\quad \left. - \frac{\bar{g}^\alpha g^\beta \bar{g}^\gamma}{2|a|^2} \left(\langle g_\beta^{H,N_{Y/X}}, \nabla_{\frac{H}{g_\alpha}}^{TX} \bar{g}_\gamma^{H,N_{Y/X}} \rangle \right) \right. \\
 &\quad \left. - \left\langle \bar{g}_\gamma^{H,N_{Y/X}}, \nabla_{\frac{H}{g_\alpha}}^{TX} g_\beta^{H,N_{Y/X}} \right\rangle - \left\langle \bar{g}_\alpha^{H,N_{Y/X}}, T^V(g_\beta^{H,V}, \bar{g}_\gamma^{H,V}) \right\rangle \right).
 \end{aligned}
 \tag{13.117}$$

Proof. Clearly

$$(13.118) \quad \left[\frac{g^\alpha}{\bar{a}} c(g_\alpha^{H, N_{Y/X}}) + \frac{\bar{g}^\alpha}{a} c(\bar{g}_\alpha^{H, N_{Y/X}}), \frac{\partial}{\partial \bar{a}} \right] = \frac{g^\alpha}{\bar{a}^2} c(g_\alpha^{H, N_{Y/X}}),$$

$$\left[\frac{g^\alpha}{\bar{a}} c(g_\alpha^{H, N_{Y/X}}) + \frac{\bar{g}^\alpha}{a} c(\bar{g}_\alpha^{H, N_{Y/X}}), \left[\frac{g^\alpha}{\bar{a}} c(g_\alpha^{H, N_{Y/X}}) + \frac{\bar{g}^\alpha}{a} c(\bar{g}_\alpha^{H, N_{Y/X}}), \frac{\partial}{\partial \bar{a}} \right] \right] = -\frac{2g^\alpha \bar{g}^\beta}{a \bar{a}^2} \left\langle g_\alpha^{H, N_{Y/X}}, \bar{g}_\beta^{H, N_{Y/X}} \right\rangle.$$

From (13.118), we deduce that

$$(13.119) \quad \exp \left\{ \frac{-g^\alpha}{\bar{a}} \frac{c(g_\alpha^{H, N_{Y/X}})}{\sqrt{2}} - \frac{\bar{g}^\alpha}{a} \frac{c(\bar{g}_\alpha^{H, N_{Y/X}})}{\sqrt{2}} \right\} d\bar{a} \left(\frac{\partial}{\partial \bar{a}} - \frac{i\omega^{V, H}}{2a\bar{a}^2} \right)$$

$$\exp \left\{ \frac{g^\alpha}{\bar{a}} \frac{c(g_\alpha^{H, N_{Y/X}})}{\sqrt{2}} + \frac{\bar{g}^\alpha}{a} \frac{c(\bar{g}_\alpha^{H, N_{Y/X}})}{\sqrt{2}} \right\} = d\bar{a} \left[\frac{\partial}{\partial \bar{a}} - \frac{g^\alpha}{\bar{a}^2} \frac{c(g_\alpha^{H, N_{Y/X}})}{\sqrt{2}} \right.$$

$$\left. - \frac{ig^\alpha \bar{g}^\beta}{2a\bar{a}^2} (\omega^V(g_\alpha^{H, N_{Y/X}}, \bar{g}_\beta^{H, N_{Y/X}}) + \omega^V(g_\alpha^V, \bar{g}_\beta^V)) \right].$$

By (7.44) and by (13.119), we find that the coefficients of $d\bar{a}$ coincide in (13.117). Also

$$(13.120) \quad \bar{\partial}^X = \frac{c(w_i)}{\sqrt{2}} \nabla_{\bar{w}_i}^{\Lambda(T^{*(0,1)}X) \otimes \xi}.$$

Using (13.120) and proceeding as in the proof of Theorem 7.17, we obtain the full (13.117). The proof of our Theorem is completed. \square

Remark 13.29. Needless to say, a strictly similar formula holds for $\tilde{A}_{u, T}^{1'}$. In both formulas $\bar{g}^\alpha \wedge \nabla_{\bar{g}_\alpha^{H, V}}^{\Lambda(T^{*(0,1)}X) \otimes \xi}$, $g^\alpha \wedge \nabla_{g_\alpha^{H, V}}^{\Lambda(T^{*(0,1)}X) \otimes \xi}$ have been replaced by $\bar{g}^\alpha \wedge \nabla_{\bar{g}_\alpha^{H, W}}^{\Lambda(T^{*(0,1)}X) \otimes \xi}$, $g^\alpha \wedge \nabla_{g_\alpha^{H, W}}^{\Lambda(T^{*(0,1)}X) \otimes \xi}$.

Now we suppose that $w_1, \dots, w_{2\ell'}$ is an orthonormal basis of TY , and $w_{2\ell'+1}, \dots, w_{2\ell}$ is an orthonormal basis of $N_{Y/X}$.

Definition 13.30. Put

$$\begin{aligned}
 \bar{\partial}^H &= \sum_1^{2\ell'} \frac{c(w_i)}{\sqrt{2}} {}_0\tilde{\nabla}_{\bar{w}_i}^{(\Lambda(T^{*(0,1)}X)\widehat{\otimes}\xi)_{|W}}, \\
 \bar{\partial}^{N_{Y/X}} &= \sum_{2\ell'+1}^{2\ell} \frac{c(w_i)}{\sqrt{2}} {}_0\tilde{\nabla}_{\bar{w}_i}^{(\Lambda(T^{*(0,1)}X)\widehat{\otimes}\xi)_{|W}}, \\
 \bar{\partial}^{H^*} &= \sum_1^{2\ell'} \frac{c(\bar{w}_i)}{\sqrt{2}} {}_0\tilde{\nabla}_{\bar{w}_i}^{(\Lambda(T^{*(0,1)}X)\widehat{\otimes}\xi)_{|W}}, \\
 \bar{\partial}^{N_{Y/X^*}} &= \sum_{2\ell'+1}^{2\ell} \frac{c(\bar{w}_i)}{\sqrt{2}} {}_0\tilde{\nabla}_{\bar{w}_i}^{(\Lambda(T^{*(0,1)}X)\widehat{\otimes}\xi)_{|W}},
 \end{aligned}
 \tag{13.121}$$

With the notation of Definition 8.2,

$$\begin{aligned}
 D^H &= \bar{\partial}^H + \bar{\partial}^{H^*}, \\
 D^{N_{Y/X}} &= \bar{\partial}^{N_{Y/X}} + \bar{\partial}^{N_{Y/X^*}}.
 \end{aligned}
 \tag{13.122}$$

Definition 13.31. Put

$$\begin{aligned}
 \mathfrak{B}^{1''} &= a\bar{\partial}^H + a \sum_1^\ell \frac{c(w_i)}{\sqrt{2}} B_y(e_i) + \frac{1}{2} \tilde{\nabla}_Z^\xi \tilde{\nabla}_Z^\xi v(y) \\
 &\quad + \bar{g}^\alpha \wedge \left({}_0\tilde{\nabla}_{(\bar{g}_\alpha^{H,W})_H}^{(\Lambda(T^{*(0,1)}X)\widehat{\otimes}\xi)_{|W}} + B_y(\bar{g}_\alpha^{H,W}) \right) \\
 &\quad + d\bar{a} \left(\frac{\partial}{\partial \bar{a}} - \frac{\bar{g}^\alpha}{\bar{a}^2} \frac{c(\bar{g}_\alpha^{H,N_{Y/X}})}{\sqrt{2}} - \frac{i}{2} \frac{\omega^{W,H}}{a\bar{a}^2} \right)_y \\
 &\quad + \frac{g^\alpha \bar{g}^\beta}{\bar{a}} \frac{c}{2\sqrt{2}} \left(P^{N_{Y/X}} T^{V(1,0)}(g_\alpha^{H,W}, \bar{g}_\beta^{H,W}) - T^{W(1,0)}(g_\alpha^{H,W}, \bar{g}_\beta^{H,W}) \right)_y.
 \end{aligned}
 \tag{13.123}$$

We define $\mathfrak{B}^{1'}$ is a similar way. Then

$$\mathfrak{B}^1 = \mathfrak{B}^{1''} + \mathfrak{B}^{1'}
 \tag{13.124}$$

is a superconnection on \mathbf{E} over $S \times \mathbf{C}^*$.

Now we use the same trivialization of $(\Lambda(T^{*(0,1)}X)\widehat{\otimes}\xi)|_{\mathfrak{u}_e}$ as in Chapter 8.

Theorem 13.32 — As $T \rightarrow +\infty$.

$$\begin{aligned}
 (13.125) \quad F_T k^{1/2} \tilde{A}_{1,T}^{1''} k^{-1/2} F_T^{-1} &= T v^+(y) + \sqrt{T} (a\bar{\partial}^{N_{Y/X}} + \tilde{\nabla}_Z^\xi v(y)) \\
 &\quad + \mathfrak{B}^{1''} + \frac{1}{\sqrt{T}} \mathcal{O} \left(|Z|^2 \partial^{N_{Y/X}} + |Z| \partial^Y + |Z| \partial^S + |Z| + |Z|^3 \right).
 \end{aligned}$$

Proof. To prove (13.125), we will use as much as we can the results already established in the proof of Theorem 8.5.

By (13.117), (13.120) and by Theorem 8.5, it is clear that (13.125) holds in degree 0. Now we consider the terms of positive degree in $\Lambda(T_{\mathbf{R}}^*S)$ not containing $d\bar{a}$. The term of degree 1 in formula (13.117) for $\tilde{A}_{1,T}^{1''}$, not containing $d\bar{a}$, is the sum of

- a factor of $\bar{g}^\alpha \wedge$, which preserves the total degree in $\Lambda(T^{*(0,1)}X) \hat{\otimes} \xi$.
- a factor of $g^\alpha \wedge$ which increases by 2 the total degree in $\Lambda(T_{\mathbf{R}}^*X) \hat{\otimes} \xi$.

Similarly the term of degree 1 in $\tilde{A}_{u,T}^{1'}$ not containing da is the sum of

- a factor of $\bar{g}^\alpha \wedge$, which decreases by 2 the total degree in $\Lambda(T_{\mathbf{R}}^*X) \hat{\otimes} \xi$.
- a factor of $g^\alpha \wedge$, which preserves the total degree in $\Lambda(T^{*(0,1)}X) \hat{\otimes} \xi$.

If we make $a = 1$ in (13.118), we find that the term of degree 1 in $\tilde{A}_{u,T}^{1''}$, which does not contain $d\bar{a}$, can be read off from the corresponding term in $\tilde{A}_{u,T}$ by selecting those terms which can be described as indicated before.

Now in the right hand side of formula (8.9) for \mathfrak{B} , the term of degree 1 in $\Lambda(T_{\mathbf{R}}^*S)$ preserves the total degree in $\Lambda(T^{*(0,1)}X) \hat{\otimes} \xi$. Thus we find easily that when making $d\bar{a} = 0$, (13.125) holds in degree 1 in $\Lambda(T_{\mathbf{R}}^*S)$.

The identity (13.125) for the term containing $d\bar{a}$ is trivial. From now on we exclude this term, together with the corresponding term in $\tilde{A}_{u,T}^{1'}$ which contains da .

In degree 2 in $\Lambda(T_{\mathbf{R}}^*S)$, in $\tilde{A}_{u,T}^{1''}$, we have sums of

- terms with $g^\alpha \bar{g}^\beta$, which increase the degree in $\Lambda(T^{*(0,1)}X) \hat{\otimes} \xi$ by 1.
- terms with $\bar{g}^\alpha \bar{g}^\beta$, which decrease the degree by 1.

Similarly in degree 2, in $\tilde{A}_{u,T}^{1'}$, we have

- terms with $g^\alpha \bar{g}^\beta$ which decrease the degree by 1.
- terms with $g^\alpha g^\beta$ which increase the degree by 1.

Again this shows that these terms can be detected from the expression (7.37) for $\tilde{A}_{u,T}$. By noting that in \mathfrak{B} , we only have terms containing $g^\alpha \bar{g}^\beta$, from (8.10), we find that (13.125) holds in degree 2.

In degree 3, $\tilde{A}_{u,T}^{1''}$ is proportional to the piece of type (1,2) in $\tilde{A}_{u,T}$. Using Theorem 8.5 again, we find that (13.125) holds in degree 3. The proof of our Theorem is completed. □

Remark 13.33. A corresponding result holds for $\tilde{A}_{u,T}^{1'}$.

Put

$$(13.126) \quad D^{N_{Y/X}, a} = a\bar{d}^{N_{Y/X}} + \bar{a}d^{N_{Y/X}*}.$$

Let $a^{1/2}$ be the natural square root of $a \in \mathbf{C}^*$ near $a = 1$.

For $a \in \mathbf{C}^*$, put

$$(13.127) \quad \beta_a = \frac{1}{a \frac{\dim N_{Y/X}}{2}} \exp \left\{ -\frac{|Z|^2}{2|a|} + \frac{a\theta}{|a|} \right\}.$$

Then by proceeding as in [6, Theorem 1.6] or [19, Theorem 7.4], one verifies very simply that for $y \in W$, β_y^a spans the one dimensional L_2 kernel of the elliptic self-adjoint operator $D^{N_{Y/X},a} + \sqrt{1} \frac{\widehat{c}(Z)}{\sqrt{2}}$ acting on the vector space of L_2 sections of $\pi^*(\Lambda(\overline{N}_{Y/X}^*) \widehat{\otimes} \Lambda(N_{Y/X}^*))$ over $N_{Y/X, \mathbf{R}, y}$, and moreover,

$$(13.128) \quad \int_{N_{Y/X, \mathbf{R}}} \|\beta_y^a\|^2 \frac{dv_{N_{Y/X}}}{(2\pi)^{\dim N_{Y/X}}} = 1.$$

We define ψ_a as in Definition 8.7, by replacing β by β^a . More generally, all the objects introduced in Chapter 8 now depend explicitly on $a \in \mathbf{C}^*$, so that the whole construction is fibered over $W \times \mathbf{C}^*$.

Put

$$(13.129) \quad \begin{aligned} B_u^{W1''} &= a\sqrt{u}\partial^Y + \nabla^{F''} + d\bar{a} \left(\frac{\partial}{\partial \bar{a}} - \frac{i\omega^{W,H}}{2ua\bar{a}^2} \right) - \frac{c(T^{W(1,0)})}{2\sqrt{2u\bar{a}}}, \\ B_u^{W1'} &= a\sqrt{u}\partial^{Y*} + \nabla^{F'} + da \left(\frac{\partial}{\partial a} - \frac{i\omega^{W,H}}{2u\bar{a}a^2} \right) - \frac{c(T^{W(1,0)})}{2\sqrt{2ua}}, \\ B_u^{W1} &= B_u^{W1''} + B_u^{W1'}. \end{aligned}$$

Needless to say, $B_u^{W1''}$ and $B_u^{W1'}$ verify identities similar to (13.108).

Now we prove the following non trivial extension of Theorems 8.8 and 13.17.

Theorem 13.34 — *The following identity holds*

$$(13.130) \quad \begin{aligned} \psi^{-1} p \mathfrak{B}^{1''} p \psi &= B_1^{W1''}, \\ \psi^{-1} p \mathfrak{B}^{1'} p \psi &= B_1^{W1'}. \end{aligned}$$

Proof. Clearly on $W \times \mathbf{C}^*$, β is of total degree 0 in $\Lambda(\overline{N}_{Y/X}^*) \widehat{\otimes} \Lambda(N_{Y/X}^*)$. Then the argument of the proof of Theorem 8.8 show that the terms not containing da or $d\bar{a}$ coincide in both sides of (13.130). By the same arguments as in Theorem 8.8,

$$(13.131) \quad \psi^{-1} p \left(-\frac{\bar{f}^\alpha}{\bar{a}} \frac{c(\bar{f}_\alpha^{H, N_{Y/X}})}{\sqrt{2}} - \frac{i \omega^{W,H}}{2 a \bar{a}^2} \right) p \psi = -\frac{i \omega^{W,H}}{2 a \bar{a}^2}.$$

So to establish the first identity in (13.130), we only need to show that

$$(13.132) \quad \psi^{-1} p \frac{\partial}{\partial \bar{a}} p \psi = \frac{\partial}{\partial \bar{a}}.$$

Equivalently, we have to show that

$$(13.133) \quad \left\langle \frac{\partial \beta_a}{\partial \bar{a}}, \beta_a \right\rangle = 0.$$

Clearly

$$(13.134) \quad \frac{\partial \beta}{\partial \bar{a}} = \left(\frac{1}{4} \frac{|Z|^2}{|a| \bar{a}} - \frac{1}{2} \frac{a}{\bar{a} |a|} \theta \right) \beta_a.$$

Then

$$(13.135) \quad \left\langle \frac{\partial \beta_a}{\partial \bar{a}}, \beta_a \right\rangle = \frac{1}{|a|^{\dim N_{Y/X}}} \int_{N_{Y/X, \mathbb{R}}} \exp \left(-\frac{|Z|^2}{|a|} \right) \left\{ \frac{1}{4} \frac{|Z|^2}{|a| \bar{a}} \left\| \exp \left(\frac{a\theta}{\bar{a}} \right) \right\|^2 - \frac{1}{2} \frac{a}{\bar{a} |a|} \left\langle \theta \exp \left(\frac{a\theta}{|a|} \right), \exp \left(\frac{a\theta}{|a|} \right) \right\rangle \right\} \frac{dv_{N_{Y/X}}(Z)}{(2\pi)^{\dim N_{Y/X}}}.$$

One has the easy

$$(13.136) \quad \left\| \exp \left(\frac{a\theta}{\bar{a}} \right) \right\|^2 = 2^{\dim N_{Y/X}},$$

$$\left\langle \theta \exp \left(\frac{a\theta}{|a|} \right), \exp \left(\frac{a\theta}{|a|} \right) \right\rangle = \frac{\dim N_{Y/X}}{2} \frac{\bar{a}}{|a|} 2^{\dim N_{Y/X}}.$$

Moreover

$$(13.137) \quad \int_{N_{Y/X}} \exp(-|Z|^2) \frac{dv_{N_{Y/X}}}{\pi^{\dim N_{Y/X}}} = 1,$$

$$\int_{N_{Y/X}} |Z|^2 \exp(-|Z|^2) \frac{dv_{N_{Y/X}}}{\pi^{\dim N_{Y/X}}} = \dim N_{Y/X}.$$

From (13.135)–(13.137), we get (13.133).

To complete the proof of the last identity in (13.137), we only need to show that

$$(13.138) \quad \psi^{-1} p \frac{\partial}{\partial \bar{a}} p \psi = \frac{\partial}{\partial \bar{a}},$$

or equivalently that

$$(13.139) \quad \left\langle \frac{\partial \beta_a}{\partial \bar{a}}, \beta_a \right\rangle = 0.$$

This identity can be proved as before. We can also use (13.128) and (13.133), from which (13.139) follows. \square

Since $A_{u,T}^{1,2}$ does not contain differentiation operators in the a or \bar{a} direction (it is a curvature, i.e. a tensor), by (13.115),

$$(13.140) \quad \tilde{A}_{u,T|a=1}^{1,2} = \exp \left\{ -\frac{f^\alpha c(f_\alpha^{H,N_{Y/X}})}{u \sqrt{2}} \right\} A_{u,T|a=1}^{1,2} \exp \left\{ \frac{f^\alpha}{u} c(f_\alpha^{H,N_{Y/X}}) \right\},$$

i.e., $\tilde{A}_{u,T|a=1}^{1,2}$ is obtained from $A_{u,T|a=1}^{1,2}$ by the same conjugation as $\tilde{A}_{u,T}^2$ is obtained from $A_{u,T}^2$ in Chapter 7. By (13.140), we get

$$(13.141) \quad \text{Tr}_s \left[N_{\mathbf{H}} \exp \left\{ -A_{u,T|a=1}^{1,2} + dad\bar{a} N_{u^2}^V \right\} \right] = \text{Tr}_s \left[N_{\mathbf{H}} \exp \left(-\tilde{A}_{u,T|a=1}^{1,2} + dad\bar{a} \tilde{N}_{u^2}^V \right) \right].$$

By using the Lichnerowicz formula (12.39), Theorems 13.32 and 13.34, (13.141), and by proceeding as in Chapter 9, it should now be clear that given $u > 0$, as $T \rightarrow +\infty$

$$(13.142) \quad \text{Tr}_s \left[N_{\mathbf{H}} \exp \left(-A_{u,T|a=1}^{1,2} + dad\bar{a} N_{u^2}^V \right) \right]^{dad\bar{a}} \rightarrow \frac{1}{2} \dim N_{Y/X} \text{Tr}_s \left[\exp \left(-B_{u^2}^{W1,2} + dad\bar{a} (N_{u^2}^W + \frac{1}{2} \dim N_{Y/X}) \right) \right]^{dad\bar{a}}.$$

By using (13.114) and the analogue of (13.113) for $B_{u^2}^{W1}$, we see that (13.142) is equivalent to (13.105).

The connection ${}^3\nabla \pi_{\check{V}}^* \Lambda(T_{\mathbf{R}}^* S) \hat{\otimes} \Lambda(\mathbf{R}^{2*}) \hat{\otimes} \Lambda(T^{*(0,1)} X)$

We use the notation of Chapter 12. First we extend Definition 13.5.

Definition 13.35. Let ${}^3\nabla \pi_{\check{V}}^* \Lambda(T_{\mathbf{R}}^* S) \hat{\otimes} \Lambda(\mathbf{R}^{2*}) \hat{\otimes} \Lambda(T^{*(0,1)} X)$ be the connection on $\pi_{\check{V}}^* \Lambda(T_{\mathbf{R}}^* S) \hat{\otimes} \Lambda(\mathbf{R}^{2*}) \hat{\otimes} \Lambda(T^{*(0,1)} X)$ along the fibres X over \mathcal{U}_ε ,

$$(13.143) \quad {}^3\nabla \pi_{\check{V}}^* \Lambda(T_{\mathbf{R}}^* S) \hat{\otimes} \Lambda(\mathbf{R}^{2*}) \hat{\otimes} \Lambda(T^{*(0,1)} X) = {}^0\nabla \pi_{\check{V}}^* \Lambda(T_{\mathbf{R}}^* S) \hat{\otimes} \Lambda(\mathbf{R}^{2*}) \hat{\otimes} \Lambda(T^{*(0,1)} X) + \left\langle \nabla^{TX} f_\alpha^{H,N_{Y/X}} + T^V (f_\alpha^{H,V}, \cdot) - A' (f_\alpha^{H,W}) P^{TX^1}, e_i \right\rangle f^\alpha c(e_i) + \frac{1}{2} \left(\left\langle S^V(\cdot) f_\alpha^{H,W}, f_\beta^{H,W} \right\rangle - \left\langle f_\alpha^{H,N_{Y/X}}, \nabla^{TX} f_\beta^{H,N_{Y/X}} \right\rangle \right) f^\alpha f^\beta + \frac{1}{\sqrt{2}} \left(c(P^{TX^1} \cdot^{(1,0)}) + \sqrt{2} \left\langle f_\alpha^{H,N_{Y/X}}, \cdot^{(1,0)} \right\rangle f^\alpha \right) da + \frac{1}{\sqrt{2}} \left(c(P^{TX^1} \cdot^{(0,1)}) + \sqrt{2} \left\langle f_\alpha^{H,N_{Y/X}}, \cdot^{(0,1)} \right\rangle f^\alpha \right) d\bar{a}.$$

In view of (12.45), (13.18), (13.143), we see that the obvious analogue of (13.19)

is now

$$(13.144) \quad \begin{aligned} {}^2\nabla\pi_{\mathbb{V}}^*\Lambda(T_{\mathbb{R}}^*S)\widehat{\otimes}\Lambda(\mathbf{R}^{2*})\widehat{\otimes}\Lambda(T^{*(0,1)}X) &= {}^3\nabla\pi_{\mathbb{V}}^*\Lambda(T_{\mathbb{R}}^*S)\widehat{\otimes}\Lambda(\mathbf{R}^{2*})\widehat{\otimes}\Lambda(T^{*(0,1)}X) \\ &+ \frac{1}{4}\langle A'(\cdot)e_i, e_j \rangle c(e_i)c(e_j) + \left\langle A'(f_{\alpha}^{H,W})P^{TX^1}, e_i \right\rangle \frac{f^{\alpha}c(e_i)}{\sqrt{2}} \\ &+ \frac{1}{\sqrt{2}}c(P^{TX^2} \cdot_{(1,0)})da + \frac{1}{\sqrt{2}}c(P^{TX^2} \cdot_{(0,1)})d\bar{a}. \end{aligned}$$

Our fibrewise trivialization of $\pi_{\mathbb{V}}^*\Lambda(T_{\mathbb{R}}^*S)\widehat{\otimes}\Lambda(\mathbf{R}^{2*})\widehat{\otimes}\Lambda(T^{*(0,1)}X)$ is now done with respect to ${}^3\nabla\pi_{\mathbb{V}}^*\Lambda(T_{\mathbb{R}}^*S)\widehat{\otimes}\Lambda(\mathbf{R}^{2*})\widehat{\otimes}\Lambda(T^{*(0,1)}X)$.

We define the operators $\mathcal{L}_{u,T}^{1,y_0} = \mathcal{M}_u^{1,y_0}$ as in (13.33), where the operator $\tilde{A}_{u,T/u}^2$ is replaced by

$$\begin{aligned} \exp \left\{ \frac{-f^{\alpha}}{u} \frac{c}{\sqrt{2}} (f_{\alpha}^{H,N_{Y/X}}) \right\} &\left(A_{u,T/u}^2 + dau \left(\frac{\partial}{\partial u} A \right)_{u,T/u} + \right. \\ &\left. d\bar{a}u \left(\frac{\partial}{\partial u} A \right)_{u,T/u} - dad\bar{a}N_{\mathbb{V}}^X \right) \exp \left\{ \frac{f^{\alpha}}{u} c(f_{\alpha}^{H,N_{Y/X}}) \right\}. \end{aligned}$$

The operators $\mathcal{L}_{u,T}^{2,y_0}, \mathcal{M}_u^{2,y_0}$ are defined as in (13.37), and $\mathcal{L}_{u,T}^{3,y_0}, \mathcal{M}_u^{3,y_0}$ as in Definition 13.8.

Using the Lichnerowicz formula (12.39) and (13.144), we get an analogue of Theorem 13.10. Theorem 13.11 remains formally unchanged, essentially because in (13.143), P^{TX^1} vanishes on $N_{Y/X,\mathbb{R}}$.

The algebraic structure of $\mathcal{L}_{u,T}^{3,y_0}$ as $u \rightarrow 0$

As in Section 12.7, we briefly explain the behaviour of $\mathcal{L}_{u,T}^{3,y_0}$ as $u \rightarrow 0$. The argument given in this Subsection will be used later in establishing estimates on $|\theta_{u,T/u} - \theta_T|$. For $1 \leq j \leq 2\ell'$, equation (13.51) is now

$$(13.145) \quad \begin{aligned} u \left\{ \frac{c^{(0)}\tau e_j}{\sqrt{2}} \right\}_u^3 (uP^{TY}Z + \frac{u}{\sqrt{T}}P^{N_{Y/X}}Z) = \\ e^j \wedge -\frac{u^2}{2}i_{e_j} - u \langle T^W(f_{\alpha}^{H,W}, P^{TY}Z), e_j \rangle f^{\alpha} + u \langle P^{TY}z, e_j \rangle da \\ + u \langle P^{TY}\bar{z}, e_j \rangle d\bar{a} + \mathcal{O} \left(u^2 \left(|P^{TY}Z|^2 + \frac{|P^{N_{Y/X}}Z|^2}{T} \right) \right) \end{aligned}$$

and for $2\ell' + 1 \leq j \leq 2\ell$, equation (13.52) is formally unchanged. Equation (13.55) is also unchanged.

Equation (13.58) still holds. Equation (13.59) is now

$$\begin{aligned}
 (13.146) \quad & \left(2\nabla\pi_{\check{\nu}}^*\Lambda(T_{\mathbf{R}}^*S)\hat{\otimes}\Lambda(\mathbf{R}^{2*})\hat{\otimes}\Lambda(T^{*(0,1)}X) - 3\nabla\pi_{\check{\nu}}^*\Lambda(T_{\mathbf{R}}^*S)\hat{\otimes}\Lambda(\mathbf{R}^{2*})\hat{\otimes}\Lambda(T^{*(0,1)}X) \right)^2 \\
 &= \frac{1}{4} \langle A'^2 e_i, e_j \rangle c(e_i)c(e_j) + \frac{1}{2} \left\langle A'^2 (f_{\alpha}^{H,W}, f_{\beta}^{H,W}) P^{TX^1}, P^{TX^1} \right\rangle f^{\alpha} f^{\beta} \\
 &+ f^{\alpha} \frac{c}{\sqrt{c}} (A'(\cdot)A'(f_{\alpha}^{H,W})P^{TX^1} \cdot) + \frac{1}{\sqrt{2}} \left\langle A'(\cdot)P^{TX^2} \cdot^{(1,0)}, e_j \right\rangle c(e_j) da \\
 &+ \frac{1}{\sqrt{2}} \left\langle A'(\cdot)P^{TX^2} \cdot^{(0,1)}, e_j \right\rangle c(e_j) d\bar{a} - \left\langle A'(f_{\alpha}^{H,W})P^{TX^1}, P^{TX^2} \cdot^{(1,0)} \right\rangle f^{\alpha} da \\
 &- \left\langle A'(f_{\alpha}^{H,W})P^{TX^1}, P^{TX^2} \cdot^{(0,1)} \right\rangle f^{\alpha} d\bar{a} + \left\langle P^{TX^2} \cdot^{(1,0)}, P^{TX^2} \cdot^{(0,1)} \right\rangle dad\bar{a}.
 \end{aligned}$$

Also observe that if $Z, Z' \in (T_{\mathbf{R}}X)_{y_0}$, if $U \in T_{\mathbf{R}}Y$,

$$\begin{aligned}
 (13.147) \quad & \langle A'_{y_0}(Z)P^{N_{Y/X}}Z', U \rangle = \langle A'_{y_0}(P^{TY}Z)P^{N_{Y/X}}Z', U \rangle \\
 &= -\langle A'_{y_0}(P^{TY}Z)U, P^{N_{Y/X}}Z' \rangle \\
 &= -\langle A'_{y_0}(U)P^{TY}Z, P^{N_{Y/X}}Z' \rangle.
 \end{aligned}$$

Put

$$\begin{aligned}
 (13.148) \quad R^{2/3} &= 2/3\nabla\pi_{\check{\nu}}^*(\Lambda(T_{\mathbf{R}}^*S)\hat{\otimes}\Lambda(\mathbf{R}^{2*})\hat{\otimes}\Lambda(T^{*(0,1)}X) \\
 &- 2/3\nabla\pi_{\check{\nu}}^*\Lambda(T_{\mathbf{R}}^*S)\hat{\otimes}\Lambda(T^{*(0,1)}X).
 \end{aligned}$$

Clearly,

$$\begin{aligned}
 (13.149) \quad & \left[3\nabla\pi_{\check{\nu}}^*\Lambda(T_{\mathbf{R}}^*S)\hat{\otimes}\Lambda(\mathbf{R}^{2*})\hat{\otimes}\Lambda(T^{*(0,1)}X), 2\nabla\pi_{\check{\nu}}^*\Lambda(T_{\mathbf{R}}^*S)\hat{\otimes}\Lambda(\mathbf{R}^{2*})\hat{\otimes}\Lambda(T^{*(0,1)}X) - \right. \\
 & \left. 3\nabla\pi_{\check{\nu}}^*\Lambda(T_{\mathbf{R}}^*S)\hat{\otimes}\Lambda(\mathbf{R}^{2*})\hat{\otimes}\Lambda(T^{*(0,1)}X) \right] = \left[3\nabla\pi_{\check{\nu}}^*\Lambda(T_{\mathbf{R}}^*S)\hat{\otimes}\Lambda(T^{*(0,1)}X), \right. \\
 & \left. 2\nabla\pi_{\check{\nu}}^*\Lambda(T_{\mathbf{R}}^*S)\hat{\otimes}\Lambda(T^{*(0,1)}X) - 3\nabla\pi_{\check{\nu}}^*\Lambda(T_{\mathbf{R}}^*S)\hat{\otimes}\Lambda(T^{*(0,1)}X) \right] \\
 &+ \left[3\nabla\pi_{\check{\nu}}^*\Lambda(T_{\mathbf{R}}^*S)\hat{\otimes}\Lambda(T^{*(0,1)}X), R^2 - R^3 \right] \\
 &+ \left[R^3, 2\nabla\pi_{\check{\nu}}^*\Lambda(T_{\mathbf{R}}^*S)\hat{\otimes}\Lambda(T^{*(0,1)}X) - 3\nabla\pi_{\check{\nu}}^*\Lambda(T_{\mathbf{R}}^*S)\hat{\otimes}\Lambda(T^{*(0,1)}X) \right] + [R^3, R^2 - R^3].
 \end{aligned}$$

Observe that since TX^1 and TX^2 are orthogonal,

$$(13.150) \quad [R^3, R^2 - R^3] = 0.$$

Now we explain how to calculate the limit of $\{u^2\psi_u 3\nabla\pi_{\check{\nu}}^*\Lambda(T_{\mathbf{R}}^*S)\hat{\otimes}\Lambda(\mathbf{R}^{2*})\hat{\otimes}\Lambda(T^{*(0,1)}X), 2\nabla\pi_{\check{\nu}}^*\Lambda(T_{\mathbf{R}}^*S)\hat{\otimes}\Lambda(\mathbf{R}^{2*})\hat{\otimes}\Lambda(T^{*(0,1)}X) - 3\nabla\pi_{\check{\nu}}^*\Lambda(T_{\mathbf{R}}^*S)\hat{\otimes}\Lambda(\mathbf{R}^{2*})\hat{\otimes}\Lambda(T^{*(0,1)}X)\}^3$ as $u \rightarrow 0$. We use the analogue of (13.58). Again we claim that no term in the right-hand side of (13.149) contributes to the limit. We already saw this after (13.62) for the first term. To see that the second term does not contribute, we use the expression (13.18) for $3\nabla\pi_{\check{\nu}}^*\Lambda(T_{\mathbf{R}}^*S)\hat{\otimes}\Lambda(T^{*(0,1)}X)$. The term

$\left[{}^0\nabla\pi_{\check{V}}^*\Lambda(T_{\mathbf{R}}^*S)\widehat{\otimes}\Lambda(T^{*(0,1)}X), R^2 - R^3\right]$ does not contribute, since $R^2 - R^3$ only contains Clifford variables in TX^2 , and ${}^0\nabla^{TX}$ preserves TX^2 . As to the second term in the right-hand side of (13.18), its bracket with $R^2 - R^3$ does not contribute to the limit, because of the second identity in (1.35) and (7.27). The third term in the right-hand side of (13.149) does not contribute to the limit, because $A'(\cdot)$ exchanges TX^1 and TX^2 .

By Proposition 11.8, (11.61), (12.46), (13.63) and by (13.146)-(13.150), we find that as $u \rightarrow 0$,

$$(13.151) \quad \left\{u^2\psi_u^3\nabla\pi_{\check{V}}^*\Lambda(T_{\mathbf{R}}^*S)\widehat{\otimes}\Lambda(\mathbf{R}^{2*})\widehat{\otimes}\Lambda(T^{*(0,1)}X),2(Z, e_i)\psi_u^{-1}\right\}_u^3 \rightarrow \\ \langle (i^*\nabla_{y_0}^{TX,2} - \sqrt{-1}P^{TY}J^{TX}P^{TY}dad\bar{a} - P^{TY}A_{y_0}^2P^{TY})Z, e_i \rangle \\ - da \langle AP^{TY}., P^{N_{Y/X}(1,0)}. \rangle - d\bar{a} \langle AP^{TY}., P^{N_{Y/X}(0,1)}. \rangle.$$

By (12.39), (13.151), we see that as $u \rightarrow 0$, the operator $\mathcal{M}_{u,1}^{3,y_0}$ converges to $\mathcal{M}_{0,T}^{3,y_0}$ given by

$$(13.152) \quad \mathcal{M}_{0,T}^{3,y_0} = -\frac{1}{2} \sum_1^{2\ell} \left(\sqrt{T}\nabla_{P^{N_{Y/X}e_i}} + \nabla_{P^{TY}e_i} \right. \\ \left. + \frac{1}{2} \left\langle (i^*(\nabla_{y_0}^{TX,2} - \sqrt{-1}P^{TY}J^{TX}P^{TY}dad\bar{a} - P^{TY}A_{y_0}^2P^{TY}) \left(P^{TY}Z + \frac{P^{N_{Y/X}Z}}{\sqrt{T}} \right), e_i \right\rangle \right. \\ \left. + \frac{1}{2} \left\langle i^*(\nabla_{y_0}^{TX,2} \frac{P^{N_{Y/X}Z}}{\sqrt{T}}, P^{TY}e_i \right\rangle - \frac{1}{2} \langle i^*\nabla_{y_0}^{TX,2}P^{TY}Z, P^{N_{Y/X}e_i} \rangle \right. \\ \left. + da \left\langle AP^{TY}e_i, \frac{P^{N_{Y/X}z}}{\sqrt{T}} \right\rangle + d\bar{a} \left\langle AP^{TY}e_i, \frac{P^{N_{Y/X}\bar{z}}}{\sqrt{T}} \right\rangle \right. \\ \left. - \frac{c(AP^{TY}e_i)}{\sqrt{2}} + \frac{1}{\sqrt{2}}c(P^{N_{Y/X}e_i^{(1,0)}})da + \frac{1}{\sqrt{2}}c(P^{N_{Y/X}e_i^{(0,1)}})d\bar{a} \right)^2 \\ + i^*(\nabla^{\xi,2} + \frac{1}{2}\text{Tr}[\nabla^{TX,2}]) - dad\bar{a} \frac{\dim X}{2}.$$

Using (13.145) and the considerations which follow, we see that to the right-hand side of (13.65), we should add

$$(13.153) \quad da\nabla_{P^{TY}z}^{\xi}v(y) + d\bar{a}\nabla_{P^{TY}\bar{z}}^{\xi}v^*(y).$$

Together with the identities (13.66), there is now the obvious

$$(13.154) \quad P^{\xi^-}(da\nabla_{P^{TY}z}^{\xi}v(y) + d\bar{a}\nabla_{P^{TY}\bar{z}}^{\xi}v^*(y))P^{\xi^-} = 0.$$

Then by (13.152), (13.154), and by proceeding as in Section 13.7, we find that as

$u \rightarrow 0,$

(13.155)

$$\theta_{u,T/u} \rightarrow - \left(\frac{1}{2\pi i} \right)^{\dim Y} \int_Y \text{Tr}_s \left[N_{\mathbf{H}} \exp(-(\mathcal{M}_{0,T}^{3,y_0} + \frac{T |P^{N_Y/X} Z|^2}{2} + TS + \frac{1}{2} \text{Tr} [R^{TX}] + R^{\Lambda(N_Y^*/X)})) \right] \text{Tr} [\exp(-\nabla^{n,2})] .$$

By using Proposition 5.32, (13.155) is equivalent to

(13.156) $\theta_{u,T/u} \rightarrow \theta_T,$

a result we already established in Section 12.7. The techniques of this Subsection will be used in Section 13.14 to establish the second half of Theorem 6.18, i.e. to obtain the estimate (6.84).

An estimate on $|\theta_{u,T/u} - \theta_u^*|$

By the previous considerations, we find that the obvious analogue of Theorem 13.14 remains true for the new operator $\mathcal{L}_{u,T}^{3,y_0}$. In fact, we have verified that the arguments of the proof of Theorem 13.14 apply verbatim to our new problem. In particular the new operator \mathcal{P}_u is still given by (13.78).

Now we explain how to extend Theorem 13.16. First we redefine the connection ${}^3\nabla^{\pi^* \Lambda(T_{\mathbf{R}}^* S) \otimes \Lambda(\mathbf{R}^{2^*}) \otimes \Lambda(T^{*(0,1)} X)}$ in formula (13.143) by keeping ${}^0\nabla^{\pi^* \Lambda(T_{\mathbf{R}}^* S) \otimes \Lambda(\mathbf{R}^{2^*}) \otimes \Lambda(T^{*(0,1)} X)}$ unchanged, and by scaling g^α into $\frac{g^\alpha}{a}$, \bar{g}^α into $\frac{\bar{g}^\alpha}{a}$, da into $\frac{da}{a}$, $d\bar{a}$ into $\frac{d\bar{a}}{a}$.

Definition 13.36. Put

(13.157)
$$\begin{aligned} \mathfrak{C}^{1''} = & a \bar{d}^H + a \sum_1^\ell \frac{c(w_i)}{\sqrt{2}} B_y(w_i) + \frac{1}{2} \tilde{\nabla}_Z^\xi \tilde{\nabla}_Z^\xi v(y) \\ & + \bar{g}^\alpha \wedge \left({}^0\nabla^{\Lambda(T^{*(0,1)} X) \otimes \xi} |_{(\bar{g}^\alpha)^H, W} + B_y(\bar{g}^\alpha)^{H,W} \right) \\ & + d\bar{a} \left(\frac{\partial}{\partial \bar{a}} - \frac{\bar{g}^\alpha}{\bar{a}^2} \frac{c(\bar{g}^\alpha)^{H,N_Y/X}}{\sqrt{2}} - \frac{i\omega^{W,H}}{2a\bar{a}^2} \right) - \frac{c(T^{W(1,0)})}{2\sqrt{2}\bar{a}} . \end{aligned}$$

We define $\mathfrak{C}^{1'}$ in a similar way.

Now we prove an analogue of Theorem 13.32, where we use the trivialization associated to ${}^3\nabla^{\pi^* \Lambda(T_{\mathbf{R}}^* S) \otimes \Lambda(\mathbf{R}^{2^*}) \otimes \Lambda(T^{*(0,1)} X)}$ instead of ${}^0\nabla^{\pi^* \Lambda(T_{\mathbf{R}}^* S) \otimes \Lambda(T^{*(0,1)} X)}$. For more details, we refer to Section 13.3.

Theorem 13.37 — As $T \rightarrow +\infty$,

$$(13.158) \quad F_T k^{1/2} \tilde{A}_{1,T}^{1''} k^{-1/2} F_T^{-1} = T v^+(y) + \sqrt{T} (a \bar{\partial}^{N_{Y/X}} + \tilde{\nabla}_z^\xi v(y)) \\ + \mathfrak{C}^{1''} + \frac{1}{\sqrt{T}} \mathcal{O}(|Z|^2 \partial^{N_{Y/X}} + |Z| \partial^Y + |Z| \partial^S + |Z| + |Z|^3).$$

Proof. Given Theorem 13.32, we proceed as in the proof of Theorem 13.16, where we used Theorem 8.5. With respect to (13.125), we have an extra contribution given by

$$(13.159) \quad \frac{1}{2} \sum_{2\ell'+1}^{2\ell} [c(P^{TY} \bar{z}) d\bar{a}, c(w_i)] \nabla_{\bar{w}_i} + \frac{1}{2} \sum_{2\ell'+1}^{2\ell} c(w_i) c(P^{TY} \bar{w}_i) d\bar{a} \\ - \frac{g^\alpha \bar{g}^\beta}{\bar{a}} \frac{c(P^{N_{Y/X}} T^{V(1,0)} (g_\alpha^{H,W}, \bar{g}_\beta^{H,W}))}{2\sqrt{2}}.$$

Since $Z \in N_{Y/X, \mathbf{R}}$, the first two terms in (13.159) vanish identically. Our Theorem now follows from Theorem 13.32. □

The obvious analogue of Theorem 13.34 is now.

Theorem 13.38 — *The following identity holds*

$$(13.160) \quad \psi^{-1} p \mathfrak{C}^{1''} p \psi = B_1^{W1''} \\ \psi^{-1} p \mathfrak{C}^{1'} p \psi = B_1^{W1'}.$$

Proof. Our Theorem follows immediately from Theorem 13.34. □

It should now be clear that the same methods as in Sections 13.1–13.12 show the existence of $C > 0$, $\delta \in]0, 1]$ such that for $u \in]0, 1]$, $T \geq 1$,

$$(13.161) \quad |\theta_{u,T/u} - \theta_u^*| \leq \frac{C}{T^\delta}.$$

13.14 A proof of the second half of Theorem 6.18

Now we will prove the second half of Theorem 6.18, i.e. we establish the existence of $C > 0$, $\rho > 0$ such that for $u \in]0, 1]$, $T \geq 1$,

$$(13.162) \quad |\theta_{u,T/u} - \theta_T| \leq C u^\rho.$$

In Section 12.7 and Subsection 13.13, we gave two proofs of the fact that for $T > 0$, as $u \rightarrow 0$

$$(13.163) \quad \theta_{u,T/u} \rightarrow \theta_T.$$

We will show how to use the formalism of the present Section 13.13 to prove (13.162).

By the previous arguments, it is clear that the analytic formalism of the whole Chapter 13 is very close to the one of [19, Section 13]. To simplify the references, we will prove, in the context of [19, Section 13], i.e. when S is a point, that there exist $C > 0, \rho > 0$ such that for $u \in]0, 1], T \geq 1$,

$$(13.164) \quad \left| \text{Tr}_s \left[N_{\mathbf{H}} \exp(-A_{u,T/u}^2) \right] - \int_Y \Phi \text{Tr}_s \left[N_{\mathbf{H}} \exp(-\mathfrak{B}_{T^2}^2) \right] \text{ch}(\eta, g^\eta) \right| \leq Cu^\rho.$$

The extension of (13.164) to the case where S is arbitrary or to the proof of (13.162) will then be essentially the same.

So now we assume for simplicity that S is a point. By (11.21), (13.2) and by proceeding as in Chapter 9, we get for $u \in]0, 1], T \geq 1$,

$$(13.165) \quad \left| \text{Tr}_s \left[N_{\mathbf{H}} \tilde{G}_u(A_{u,T/u}^2) \right] \right| \leq c \exp\left(\frac{-C}{u^2}\right).$$

So to establish (13.164), we only need to show that

$$(13.166) \quad \left| \text{Tr}_s \left[N_{\mathbf{H}} \tilde{F}_u(A_{u,T/u}^2) \right] - \int_Y \Phi \text{Tr}_s \left[N_{\mathbf{H}} \exp(-\mathfrak{B}_{T^2}) \right] \text{ch}(\eta, g^\eta) \right| \leq Cu^\rho.$$

Take $y_0 \in Y$. We replace $\tilde{F}_u(A_{u,T/u}^2)$ by $\tilde{F}_u(\mathcal{L}_{u,T}^{3,y_0})$ as in [19, Section 13 g)] or in (13.38). By [19, Theorem 13.32], we know that given $M > 0$, there exist $C > 0, C' > 0$, such that for $u \in]0, 1], T \geq 1$, we have the uniform bounds

$$(13.167) \quad \begin{aligned} & \sup_{\substack{Z_0 \in N_{Y/X, \mathbf{R}, y_0} \\ |Z_0| \leq \frac{\varepsilon\sqrt{T}}{4u}}} (1 + |Z_0|)^m \left| \tilde{F}_u(\mathcal{L}_{u,T}^{3,y_0})(Z_0, Z_0) \right| \leq C, \\ & \sup_{\substack{Z, Z' \in (T_{\mathbf{R}}X)_{y_0}, \\ |P^{TY} Z|, |P^{TY} Z'| \leq M \\ |P^{NY/X} Z|, |P^{NY/X} Z'| \leq \frac{\varepsilon\sqrt{T}}{4u} \\ |\alpha|, |\alpha'| \leq m'}} \left| \frac{\partial^{|\alpha|+|\alpha'|}}{\partial Z^\alpha \partial Z'^{\alpha'}} \tilde{F}_u(\mathcal{L}_{u,T}^{3,y_0})(Z, Z') \right| \leq C'. \end{aligned}$$

By [19, eq. (13.143)] or by (13.98), if $s \in \mathbf{K}_{y_0}^1$,

$$(13.168) \quad |s^+|_{u,T,y_0,1} \leq \frac{Cu |s|_{u,T,y_0,0}}{T}.$$

By [19, Theorem 13.28], we get for $\lambda \in U, u \in]0, 1], T \geq T_0$,

$$(13.169) \quad \left\| \left(\lambda - \mathcal{L}_{u,T}^{3,y_0} \right)^{-1} \right\|_{u,T,y_0}^{-1,1} \leq C(1 + |\lambda|)^2.$$

Using (13.168), (13.169), we obtain easily

$$(13.170) \quad \begin{aligned} & \left\| P^{\xi^+} \left(\lambda - \mathcal{L}_{u,T}^{3,y_0} \right)^{-1} P^{\xi^+} \right\|_{u,T,y_0}^{0,0} \leq \frac{Cu(1+|\lambda|)^2}{T}, \\ & \left\| P^{\xi^+} \left(\lambda - \mathcal{L}_{u,T}^{3,y_0} \right)^{-1} P^{\xi^-} \right\|_{u,T,y_0}^{0,0} \leq \frac{Cu(1+|\lambda|)^2}{T}, \\ & \left\| P^{\xi^-} \left(\lambda - \mathcal{L}_{u,T}^{3,y_0} \right)^{-1} P^{\xi^+} \right\|_{u,T,y_0}^{0,0} \leq \frac{Cu(1+|\lambda|)^2}{T}. \end{aligned}$$

By [19, eq. (13.241)], for $T \geq T_0$,

$$(13.171) \quad \tilde{F}_u(\mathcal{L}_{u,T}^{3,y_0}) = \frac{1}{2\pi i} \int_{\Gamma} \tilde{F}_u(\lambda) (\lambda - \mathcal{L}_{u,T}^{3,y_0})^{-1} d\lambda.$$

From (11.10), (13.171), we get

$$(13.172) \quad \begin{aligned} & \left\| P^{\xi^+} \tilde{F}_u \left(\mathcal{L}_{u,T}^{3,y_0} \right) P^{\xi^+} \right\|_{u,T,y_0}^{0,0} \leq \frac{Cu}{T}, \\ & \left\| P^{\xi^+} \tilde{F}_u \left(\mathcal{L}_{u,T}^{3,y_0} \right) P^{\xi^-} \right\|_{u,T,y_0}^{0,0} \leq \frac{Cu}{T}, \\ & \left\| P^{\xi^-} \tilde{F}_u \left(\mathcal{L}_{u,T}^{3,y_0} \right) P^{\xi^+} \right\|_{u,T,y_0}^{0,0} \leq \frac{Cu}{T}. \end{aligned}$$

If $s \in \mathbf{K}_{y_0}^-$, has compact support, put

$$(13.173) \quad \begin{aligned} |s|_{0,T,y_0,1}^2 &= T |p^\perp s|_{0,T,y_0,0}^2 + T \| |P^N Z| p^\perp s \|_{0,T,y_0,0}^2 \\ &+ |ps|_{0,T,y_0,0}^2 + \sum_1^{2\ell'} |\nabla_{e_i} s|_{0,T,y_0,0}^2 + T \sum_{2\ell'+1}^{2\ell} |\nabla_{e_i} p^\perp s|_{0,T,y_0,0}^2. \end{aligned}$$

Observe that

$$(13.174) \quad |s|_{0,T,y_0,1}^2 = \lim_{u \rightarrow 0} |s|_{u,T,y_0,1}^2.$$

Let $\mathbf{K}_{y_0}^{0,-}$, $\mathbf{K}_{y_0}^{1,-}$ be the obvious Hilbert spaces associated to the norms $| \cdot |_{0,T,y_0,0}$ and $| \cdot |_{1,T,y_0,0}$.

If $k = 0, 1$, $k' \in \mathbf{N}$, if $s \in \mathbf{K}^-$ has compact support, put

$$(13.175) \quad |s|_{0,T,y_0,(k,k')}^2 = \sum_{|\alpha| \leq k'} |Z^\alpha s|_{0,T,y_0,k}^2.$$

Recall that for $y_0 \in W$, $u > 0$, the operator \mathcal{D}_u^{2,y_0} (which is attached here to the exact sequence $0 \rightarrow TY \rightarrow TX|_W \rightarrow N_{Y/X} \rightarrow 0$) has been described in Theorem 5.8. Also $G_{u,T}$ has been defined in (13.36).

Now we prove an analogue of Theorem 12.9. The whole point is that while in Theorem 12.9, $T = 1$, here $T \geq 1$.

Theorem 13.39 — *There exist $C > 0$, $p \in \mathbf{N}$ such that if $u \in]0, 1]$, $T \geq T_0$, $\lambda \in U$, if $s \in \mathbf{K}^-$ has compact support,*

$$(13.176) \quad \left| (P^{\xi^-} \mathcal{L}_{u,T}^{3,y_0} P^{\xi^-} + P^{\xi^-} \mathcal{L}_{u,T}^{3,y_0} P^{\xi^+} (\lambda - P^{\xi^+} \mathcal{L}_{u,T}^{3,y_0} P^{\xi^+})^{-1} \right. \\ \left. P^{\xi^+} \mathcal{L}_{u,T}^{3,y_0} P^{\xi^-} - G_{1,T}^{-1} \mathcal{D}_{T^2}^{2,y_0} G_{1,T} - \nabla_{y_0}^{\eta,2} \right) s \Big|_{u,T,y_0,-1} \leq Cu(1 + |\lambda|)^p |s|_{0,T,y_0,(1,4)} .$$

Proof. Consider the operator $\mathcal{M}_{0,T}^{3,y_0}$ in (13.152), with $da = 0$, $d\bar{a} = 0$. First, we claim that

$$(13.177) \quad \left| \left(P^{\xi^-} \mathcal{L}_{u,T}^{3,y_0} P^{\xi^-} - P^{\xi^-} \mathcal{M}_{0,T}^{3,y_0} P^{\xi^-} - TS_{y_0} - \frac{T |P^{N_{Y/X}} Z|^2}{2} \right) s \right|_{u,T,y_0,-1} \\ \leq Cu |s|_{0,T,y_0,(1,4)} .$$

□

First we consider the contribution of $\mathcal{M}_{u,T}^{3,y_0}$ to (13.177). Recall that $\mathcal{M}_{u,T}^{3,y_0}$ is given by [19, eq. (13.87)], which corresponds to (13.40). Clearly for $1 \leq i \leq 2\ell'$,

$$(13.178) \quad {}^0\tau e_i(uP^{TY} Z + \frac{u}{\sqrt{T}} P^{N_{Y/X}} Z) = {}^0\tau e_i(uP^{TY} Z) + \mathcal{O} \left(\frac{u |P^{N_{Y/X}} Z|}{\sqrt{T}} \right) .$$

From (13.178), we find that since ${}^0\tau e_i(uP^{TY} Z) \in (T_{\mathbf{R}Y})_{y_0}$,

$$(13.179) \quad \sqrt{T} P^{N_{Y/X}} {}^0\tau e_i(uP^{TY} Z + \frac{u}{\sqrt{T}} P^{N_{Y/X}} Z) = \mathcal{O}(u |P^{N_{Y/X}} Z|) , \\ P^{TY} {}^0\tau e_i(uP^{TY} Z + \frac{u}{\sqrt{T}} P^{N_{Y/X}} Z) = {}^0\tau e_i(0) + \mathcal{O} \left(u |P^{TY} Z| + \frac{u}{\sqrt{T}} |P^{N_{Y/X}} Z| \right) .$$

Also by [19, eq. (13.122)], for $2\ell' + 1 \leq i \leq 2\ell$,

$$(13.180) \quad {}^0\tau e_i(uP^{TY} Z + \frac{u}{\sqrt{T}} P^{N_{Y/X}} Z) = {}^0\tau e_i(uP^{TY} Z) + \mathcal{O} \left(\frac{u^2 |P^{N_{Y/X}} Z|^2}{T} \right) .$$

Moreover, in the considered trivialization of X ,

$$(13.181) \quad \sum_{2\ell'+1}^{2\ell} \nabla_{0\tau e_i(uP^{TY} Z)}^2 = \Delta^{N_{Y/X}} .$$

Also by [19, Theorem 13.19] (which corresponds to Theorem 13.11)

$$\begin{aligned}
 (13.182) \quad & P^{\xi^-} T \sum_{2\ell'+1}^{2\ell} \frac{c}{\sqrt{2}} ({}^0\tau e_i) \nabla_{0\tau e_i}^\xi V(uP^{TY}Z + \frac{u}{\sqrt{T}}P^{N_{Y/X}}Z) P^{\xi^-} = \\
 & TS_{y_0} + u\sqrt{T}P^{\xi^-} \sum_{2\ell'+1}^{2\ell} c(e_i) \tilde{\nabla}_{P^{N_{Y/X}}Z}^\xi \nabla_{0\tau e_i}^\xi V(uP^{TY}Z) P^{\xi^-} + \mathcal{O}(u^2 P^{N_{Y/X}}|Z|^2), \\
 & P^{\xi^-} \frac{T}{u} \sum_1^{2\ell'} (e^i \wedge -\frac{u^2}{2}i_{e_i}) \nabla_{0\tau e_i}^\xi V(uP^{TY}Z + \frac{u}{\sqrt{T}}P^{N_{Y/X}}Z) P^{\xi^-} = \mathcal{O}(u|P^{N_{Y/X}}Z|^2), \\
 & P^{\xi^-} \frac{T^2}{u^2} V^2(uP^{TY}Z + \frac{u}{\sqrt{T}}P^{N_{Y/X}}Z) P^{\xi^-} = \frac{T}{2} |P^{N_{Y/X}}Z|^2 + \frac{u\sqrt{T}}{2} \\
 & \left[\sqrt{-1} \frac{\hat{c}}{\sqrt{2}} (P^{N_{Y/X}}Z), \tilde{\nabla}_{P^{N_{Y/X}}Z}^\xi \tilde{\nabla}_{P^{N_{Y/X}}Z}^\xi V^-(uP^{TY}Z) \right] + \mathcal{O}(u^2 |P^{N_{Y/X}}Z|^2).
 \end{aligned}$$

From (13.179)-(13.182), we get (13.177) easily.

As in [19, eq. (12.74)] and in (12.60), put

$$\begin{aligned}
 (13.183) \quad & L_{u,1} = P^{\xi^-} \mathcal{L}_{u,T}^{3,y_0} P^{\xi^-} \quad , \quad L_{u,2} = P^{\xi^-} \mathcal{L}_{u,T}^{3,y_0} P^{\xi^+} \quad , \\
 & L_{u,3} = P^{\xi^+} \mathcal{L}_{u,T}^{3,y_0} P^{\xi^-} \quad , \quad L_{u,4} = P^{\xi^+} \mathcal{L}_{u,T}^{3,y_0} P^{\xi^+} \quad .
 \end{aligned}$$

Also we define $L'_{u,2/3}, L''_{u,2/3}, L'_{u,4}, L''_{u,4}, L'''_{u,4}$ as in [19, eq. (12.97), (12.104)], so that

$$\begin{aligned}
 (13.184) \quad & L_{u,2/3} = L'_{u,2/3} + \frac{L''_{u,2/3}}{u} \quad , \\
 & L_{u,4} = L'_{u,4} + \frac{L''_{u,4}}{u} + \frac{L'''_{u,4}}{u^2} \quad .
 \end{aligned}$$

Observe that our $\mathcal{L}_{u,T}^{3,y_0}$ corresponds to $\mathcal{L}_{u,T/u}^{3,y_0}$ in Chapter 12.

Take $\sigma \in \mathbf{K}_{y_0}^-$ with compact support. Then [19, eq. (12.99)] is now

$$\begin{aligned}
 (13.185) \quad & |L'_{u,2}(\lambda - L_{u,4})^{-1} L'_{u,3}\sigma|_{u,T,y_0,-1} \leq CT |(\lambda - L_{u,4})^{-1} L'_{u,3}\sigma|_{u,T,y_0,0} \\
 & \leq Cu |(\lambda - L_{u,4})^{-1} L'_{u,3}\sigma|_{u,T,y_0,1} \\
 & \leq C(1 + |\lambda|)^2 u |L'_{u,3}\sigma|_{u,T,0,-1} \\
 & \leq C(1 + |\lambda|)^2 u |\sigma|_{u,T,0,1}
 \end{aligned}$$

(in the first and last inequalities, we used the fact that scalar differential operators

preserve $\xi_{y_0}^+$ and $\xi_{y_0}^-$). The analogue of [19, eq. (12.100)] is

$$\begin{aligned}
 & \left| L'_{u,2}(\lambda - L_{u,4})^{-1} \frac{L''_{u,3}}{u} \sigma \right|_{u,T,y_0,-1} \leq C(1 + |\lambda|)^2 |L''_{u,3} \sigma|_{u,T,y_0,-1} \\
 & \leq \frac{C(1 + |\lambda|)^2 u}{T} |L''_{u,3} \sigma|_{u,T/u,y_0,0} \leq C(1 + |\lambda|)^2 u |\sigma|_{u,T,y_0,0}, \\
 & \left| \frac{L''_{u,2}}{u} (\lambda - L_{u,4})^{-1} L'_{u,3} \sigma \right|_{u,T,y_0,-1} \leq \frac{CT}{u} |(\lambda - L_{u,4})^{-1} L'_{u,3} \sigma|_{u,T,y_0,0} \\
 & \leq C |(\lambda - L_{u,4})^{-1} L'_{u,3} \sigma|_{u,T,y_0,1} \\
 & \leq C(1 + |\lambda|)^2 |L'_{u,3} \sigma|_{u,T,y_0,-1} \leq \frac{C(1 + |\lambda|)^2 u}{T} |L'_{u,3} \sigma|_{u,T,y_0,0} \\
 & \leq C(1 + |\lambda|)^2 u |\sigma|_{u,T,y_0,1}, \\
 (13.186) \quad & \left| \frac{L''_{u,2}}{u} (\lambda - L_{u,4})^{-1} \left(\frac{L''_{u,3} - L''_{0,3}}{u} \right) \sigma \right|_{u,T,y_0,0} \\
 & \leq \frac{CT}{u^2} |(\lambda - L_{u,4})^{-1} (L''_{u,3} - L''_{0,3}) \sigma|_{u,T,y_0,-1} \\
 & \leq \frac{C(1 + |\lambda|)^2}{u} |(\lambda - L_{u,4})^{-1} (L''_{u,3} - L''_{0,3}) \sigma|_{u,T,y_0,1} \\
 & \leq \frac{C(1 + |\lambda|)^2}{u} |(L''_{u,3} - L''_{0,3}) \sigma|_{u,T,y_0,-1} \\
 & \leq \frac{C(1 + |\lambda|)^2}{T} |(L''_{u,3} - L''_{0,3}) \sigma|_{u,T,y_0,0} \\
 & \leq C(1 + |\lambda|)^2 u |(1 + |Z|) \sigma|_{u,T,y_0,0}.
 \end{aligned}$$

The analogue of [19, eq. (12.101)-(12.103)] is

$$\begin{aligned}
 & \left| \frac{L''_{u,2} - L''_{0,2}}{u} (\lambda - L_{u,4})^{-1} \frac{L''_{0,3}}{u} \sigma \right|_{u,T,y_0,-1} \\
 & \leq \frac{CT}{u} |(1 + |Z|^2)^{1/2} (\lambda - L_{u,4})^{-1} L''_{0,3} \sigma|_{u,T,y_0,0} \\
 (13.187) \quad & \leq C |(1 + |Z|^2)^{1/2} (\lambda - L_{u,4})^{-1} L''_{0,3} \sigma|_{u,T,y_0,1} \\
 & \leq C(1 + |\lambda|)^p |(1 + |Z|^2)^{1/2} L''_{0,3} \sigma|_{u,T,y_0,-1} \\
 & \leq \frac{C(1 + |\lambda|)^p u}{T} |(1 + |Z|^2)^{1/2} L''_{0,3} \sigma|_{u,T,y_0,0} \\
 & \leq C(1 + |\lambda|)^p u |(1 + |Z|) \sigma|_{u,T,y_0,0}
 \end{aligned}$$

(to establish the third inequality, some manipulations on commutators similar to the ones in [19, Proposition 11.34] are needed).

The analogue of [19, eq. (12.107)] is

$$\begin{aligned}
 & \left| L''_{0,2}(\lambda - L_{u,4})^{-1} \frac{L''_{u,4}}{u} (\lambda u^2 - L'''_{u,4})^{-1} L''_{0,3} \sigma \Big|_{u,T,y_0,-1} \right. \\
 & \leq \frac{Cu^2}{T} \left| (\lambda - L_{u,4})^{-1} \frac{L''_{u,4}}{u} (\lambda u^2 - L'''_{u,4})^{-1} L''_{0,3} \sigma \Big|_{u,T,y_0,1} \right. \\
 (13.188) \quad & \leq C(1 + |\lambda|)^2 \frac{u^2}{T} \left| \frac{L''_{u,4}}{u} (\lambda u^2 - L'''_{u,4})^{-1} L''_{0,3} \sigma \Big|_{u,T,y_0,-1} \right. \\
 & \leq \frac{C(1 + |\lambda|)^2 u^2}{T^2} \left| L''_{u,4} (\lambda u^2 - L'''_{u,4})^{-1} L''_{0,3} \sigma \Big|_{u,T,y_0,0} \right. \\
 & \leq \frac{C(1 + |\lambda|)^2 u^2}{T^2} |\sigma|_{u,T,y_0,0} .
 \end{aligned}$$

The analogue of [19, eq. (12.108)] is

$$\begin{aligned}
 & \left| L''_{0,2}(\lambda - L_{u,4})^{-1} L'_{u,4} (\lambda u^2 - L'''_{u,4})^{-1} L''_{0,3} \sigma \Big|_{u,T,y_0,-1} \right. \\
 (13.189) \quad & \leq \frac{Cu^2}{T} \left| (\lambda - L_{u,4})^{-1} L'_{u,4} (\lambda u^2 - L'''_{u,4})^{-1} L''_{0,3} \sigma \Big|_{u,T,y_0,1} \right. \\
 & \leq \frac{C(1 + |\lambda|)^2 u^2}{T} \left| L'_{u,4} (\lambda u^2 - L'''_{u,4})^{-1} L''_{0,3} \sigma \Big|_{u,T,y_0,-1} .
 \end{aligned}$$

If $\tau \in \mathbf{K}^+$ has compact support, put

$$(13.190) \quad |\tau|_{u,T,y_0,1}^{\sim,2} = |\tau|_{u,T,y_0,0}^2 + \sum_1^{2\ell} |\nabla_{e_i} s|_{u,T,y_0,0}^2 .$$

Then

$$(13.191) \quad |\tau|_{u,T,y_0,1}^{\sim} \leq |\tau|_{u,T,y_0,1} .$$

Let $|\cdot|_{u,T,y_0,-1}^{\sim}$ be the corresponding dual norm. From (13.189)-(13.191), we obtain

$$\begin{aligned}
 & \left| L''_{0,2}(\lambda - L_{u,4})^{-1} L'_{u,4} (\lambda u^2 - L'''_{u,4})^{-1} L''_{0,3} \sigma \Big|_{u,T,0,-1} \right. \\
 (13.192) \quad & \leq \frac{C(1 + |\lambda|)^2 u^2}{T} \left| L'_{u,4} (\lambda u^2 - L'''_{u,4})^{-1} L''_{0,3} \sigma \Big|_{u,T,y_0,-1}^{\sim} \right. \\
 & \leq C(1 + |\lambda|)^2 u^2 \left| (\lambda u^2 - L'''_{u,4})^{-1} L''_{0,3} \sigma \Big|_{u,T,y_0,1}^{\sim} \right. \\
 & \leq \frac{C(1 + |\lambda|)^2 u^2}{T} |\sigma|_{u,T,y_0,1}^{\sim} \leq \frac{C(1 + |\lambda|)^2 u^2}{T} |\sigma|_{u,T,y_0,1} .
 \end{aligned}$$

By (13.188)-(13.192), we get

$$\begin{aligned}
 (13.193) \quad & \left| \left(\frac{L''_{0,2}}{u} (\lambda - L_{u,4})^{-1} \frac{L''_{0,3}}{u} - L''_{0,2} (\lambda u^2 - L'''_{u,4})^{-1} L''_{0,3} \right) \sigma \Big|_{u,T,y_0,-1} \right. \\
 & \leq \frac{C(1 + |\lambda|)^2 u}{T} |\sigma|_{u,T,y_0,1} .
 \end{aligned}$$

Also

$$\begin{aligned}
 & |(L''_{0,2}(\lambda u^2 - L'''_{u,4})^{-1}L''_{0,3} + L''_{0,2}(L'''_{0,4})^{-1}L''_{0,3})\sigma|_{u,T,y_0,-1} \\
 & \leq CT |((\lambda u^2 - L'''_{u,4})^{-1} + (L'''_{0,4})^{-1})L''_{0,3}\sigma|_{u,T,y_0,0} \\
 (13.194) \quad & \leq \frac{C}{T^3} (|\lambda|u^2 + T^2u|Z|)L''_{0,3}\sigma|_{u,T,y_0,0} \\
 & \leq Cu \left(\frac{u|\lambda|}{T^2} |\sigma|_{u,T,y_0,0} + |Z\sigma|_{u,T,y_0,0} \right).
 \end{aligned}$$

By (13.177), (13.185)–(13.187), (13.193)–(13.194), we get (13.176). The proof of our Theorem is completed. \square

Using (13.167) and Theorem 13.39, we proceed as in [19, Sections 11 p) and 13 q)] to get (13.166).

The proof of the second half of Theorem 6.18 is completed. \square

14. A proof of Theorem 0.2

In this Chapter we establish Theorem 0.2. The proof is much simpler than the corresponding proof of Theorem 0.1. At a formal level, it simply consists in exchanging the role of the parameters u and T in the proof of Theorem 0.1. Because of the formal similarities, we simply sketch the main steps in the proof of Theorem 0.2, leaving the details to the reader.

The Chapter is organized as follows. In Section 14.1 we establish an identity $\sum_{k=1}^4 I_k'^0 = \Phi(\bar{\partial}\gamma'^0 + \partial\delta'^0)$, which depends on parameters ε, A, T_0 with $0 < \varepsilon < 1 < A < +\infty, 1 < T_0$. In Section 14.2, we briefly study the asymptotics of the $I_k'^0$. In Section 14.3, we show that the divergences of the $I_k'^0$ add up to 0 in $P^S/P^{S,0}$. Finally in Section 14.4, we prove Theorem 0.2.

In this Chapter, we use the notations of Chapters 3, 4, 6. Recall that $H(X, \xi|_X) \simeq H(Y, \eta|_Y)$ is a vector bundle on S . Also, here, we assume that for $i \geq 1, 0 \leq k \leq m, H^i(X, \xi_k|_X) = 0$. This implies that for $i \geq 1, H^i(Y, \eta|_Y) = 0$. Also the $H^0(X, \xi_k|_X)$ ($0 \leq k \leq m$) are holomorphic vector bundles on S .

14.1 A closed form on $\mathbf{R}_+^* \times \mathbf{R}_+^*$

Put

$$(14.1) \quad B'_{u,T} = A_{uT,u}.$$

Let $\beta'_{u,T}$ be the form on $\mathbf{R}_+^* \times \mathbf{R}_+^* \times S$

$$(14.2) \quad \beta'_{u,T} = \frac{dT}{T} \text{Tr}_s \left[N_{(uT)^2}^V \exp(-B_{u,T}'^2) \right] + \frac{du}{u} \text{Tr}_s \left[(N_{(uT)^2}^V - N_{\mathbf{H}}) \exp(-B_{u,T}'^2) \right].$$

Using Theorem 4.1, we obtain the obvious analogue of Theorem 4.3, i.e. a formula of the type

$$(14.3) \quad d_{u,T} \beta'_{u,T} = \bar{\partial} \theta_{u,T} + \partial \theta'_{u,T}.$$

Let $\Gamma = \Gamma_{\varepsilon, A, T_0}$ be the contour considered in Section 4.3. By (14.3), we obtain the obvious analogue of Theorem 4.5, i.e.

$$(14.4) \quad \int_{\Gamma} \beta' = \bar{\partial}\gamma' + \partial\delta'.$$

For $1 \leq k \leq 4$, put

$$(14.5) \quad I_k'^0 = \int_{\Gamma_k} \Phi \beta'.$$

Then (14.4) is equivalent to

$$(14.6) \quad \sum_{k=1}^4 I_k'^0 = \Phi(\bar{\partial}\gamma'^0 + \partial\delta'^0).$$

We will make $A \rightarrow +\infty$, $T_0 \rightarrow +\infty$, $\varepsilon \rightarrow 0$ in this order in identity (14.6). We will just sketch the study of the behaviour of the terms $I_k'^0$ ($1 \leq k \leq 4$), without studying in detail the right-hand side of (14.6).

14.2 The asymptotics of the $I_k'^0$'s

The term $I_1'^0$

We have

$$(14.7) \quad I_1'^0 = \int_{\varepsilon}^A \Phi \operatorname{Tr}_s \left[(N_{(uT)^2}^V - N_{\mathbf{H}}) \exp(-B_{u, T_0}'^2) \right] \frac{du}{u}.$$

$\alpha)$ $A \rightarrow +\infty$

By Theorem 6.6, since $H(X, \xi|_X)$ is concentrated in degree 0,

$$(14.8) \quad I_1'^0 \rightarrow I_1'^1 = \int_{\varepsilon}^{+\infty} \Phi \operatorname{Tr}_s \left[(N_{(uT)^2}^V - N_{\mathbf{H}}) \exp(-B_{u, T_0}'^2) \right] \frac{du}{u}.$$

$\beta)$ $T_0 \rightarrow +\infty$

Clearly

$$(14.9) \quad \{B_{u, T_0}'^2\}^{(0)} = u^2(T_0 D^X + V)^2.$$

Over S , we have a holomorphic complex of Hermitian vector bundles

$$(14.10) \quad (\mathcal{H}, v): 0 \rightarrow H^0(X, \xi_m) \xrightarrow{v} \cdots \xrightarrow{v} H^0(X, \xi_0) \rightarrow 0,$$

whose pointwise homology is concentrated in degree 0. Let $v^{\mathcal{H}*}$ be the adjoint of v with respect to the L_2 Hermitian metric on \mathcal{H} induced by (2.22). Put

$$(14.11) \quad V^{\mathcal{H}} = v + v^{\mathcal{H}*} .$$

Using the identification $\mathcal{H} \simeq \ker D^X$, we get

$$(14.12) \quad V^{\mathcal{H}} = P^{\ker D^X} V P^{\ker D^X} .$$

Let $\nabla^{\mathcal{H}}$ be the holomorphic Hermitian connection on \mathcal{H} . By proceeding as in Chapter 9 (in a much simpler situation), we find that for a given $u > 0$, as $T \rightarrow +\infty$,

$$(14.13) \quad \text{Tr}_s \left[(N_{(uT)^2}^V - N_{\mathbf{H}}) \exp(-B_{u,T_0}'^2) \right] \rightarrow - \text{Tr}_s \left[N_{\mathbf{H}} \exp(-(\nabla^{\mathcal{H}} + uV)^2) \right] .$$

Since for $1 \leq i \leq \dim X$, $0 \leq k \leq m$, $H^i(X, \xi_{k|X}) = 0$, the spectral sequence associated to the complex $(E, \bar{\partial}^X + v)$ and the partial grading by $N_{\mathbf{V}}^X$ degenerates at E_2 . In particular

$$(14.14) \quad H^\cdot(X, \xi_{|X}) \simeq \ker V^{\mathcal{H}} \simeq H^\cdot(\mathcal{H}, v) .$$

By proceeding as in [19, Section 9], one derives easily from (14.13), (14.14) that as $T_0 \rightarrow +\infty$,

- the spectrum of $T_0 D^X + V$ converges to $\pm\infty$ and to the spectrum of $V^{\mathcal{H}}$ (counted with multiplicity).
- The nonzero eigenvalues of $T_0 D^X + V$ stay away from 0.

These two facts allow us to establish the required uniformity in the integral in the right-hand side of (14.8). Using (14.13), as $T_0 \rightarrow +\infty$,

$$(14.15) \quad I_1'^1 \rightarrow I_1'^2 = - \int_{\varepsilon}^{+\infty} \Phi \text{Tr}_s \left[N_{\mathbf{H}} \exp(-(\nabla^{\mathcal{H}} + uV)^2) \right] \frac{du}{u} .$$

$\gamma)$ $\varepsilon \rightarrow 0$

Put

$$(14.16) \quad \begin{aligned} \text{ch}(\mathcal{H}, g^{\mathcal{H}}) &= \sum_{i=0}^m (-1)^i \text{ch}(H^0(X, \xi_{i|X}), g^{H^0(X, \xi_{i|X})}) , \\ \text{ch}'(\mathcal{H}, g^{\mathcal{H}}) &= \sum_{i=0}^m (-1)^i i \text{ch}(H^0(X, \xi_{i|X}), g^{H^0(X, \xi_{i|X})}) . \end{aligned}$$

Clearly

$$(14.17) \quad I_1'^2 - \text{ch}'(\mathcal{H}, g^{\mathcal{K}}) \log(\varepsilon) \rightarrow \\ I_1'^3 = - \int_0^1 \Phi \left(\text{Tr}_s \left[N_{\mathbf{H}} \exp(-(\nabla^{\mathcal{K}} + uV)^2) \right] - \text{Tr}_s \left[N_{\mathbf{H}} \exp(-\nabla^{\mathcal{K},2}) \right] \right) \frac{du}{u} \\ - \int_1^{+\infty} \Phi \text{Tr}_s \left[N_{\mathbf{H}} \exp(-(\nabla^{\mathcal{K}} + uV)^2) \right] \frac{du}{u}.$$

δ) Evaluation of $I_1'^3$

We have an exact sequence of holomorphic vector bundles on S

$$(14.18) \quad 0 \rightarrow H^0(X, \xi_m) \xrightarrow{v} \dots \xrightarrow{v} H^0(X, \xi_0) \rightarrow H^0(\mathcal{H}, v) \rightarrow 0.$$

Clearly the $H^0(X, \xi_i)$ ($0 \leq i \leq m$), whose direct sum is \mathcal{H} , are equipped with the L_2 Hermitian metric induced by (2.22). Also since $H^0(\mathcal{H}, v) \simeq \ker V^{\mathcal{K}}$, $H^0(\mathcal{H}, v)$ is also equipped with a Hermitian metric $g^{H^0(\mathcal{H},v)}$.

Let $\tilde{\text{ch}}((\mathcal{H}, g^{\mathcal{K}}), (H(\mathcal{H}, g^{\mathcal{K}}), g^{H(\mathcal{H},g^{\mathcal{K}})})) \in P^S/P^{S,0}$ be the Bott-Chern class of [13, Section 1f)], such that

$$(14.19) \quad \frac{\bar{\partial}\partial}{2i\pi} \tilde{\text{ch}}((\mathcal{H}, g^{\mathcal{K}}), (H(\mathcal{H}, g^{\mathcal{K}}), g^{H(\mathcal{H},g^{\mathcal{K}})})) = \\ \text{ch}(H(\mathcal{H}, g^{\mathcal{K}}), g^{H(\mathcal{H},g^{\mathcal{K}})}) - \text{ch}(\mathcal{H}, g^{\mathcal{K}}).$$

Proposition 14.1 — *The following identity holds*

$$(14.20) \quad I_1'^3 = -\frac{1}{2} \left(\tilde{\text{ch}} \left((\mathcal{H}, g^{\mathcal{K}}), (H(\mathcal{H}, v), g^{H(\mathcal{H},v)}) \right) + \Gamma'(1) \text{ch}'(\mathcal{H}, g^{\mathcal{K}}) \right) \text{ in } P^S/P^{S,0}.$$

Proof. By using the transgression formulas of [13, Theorem 1.15], one finds easily that $\frac{\bar{\partial}\partial}{2i\pi}(-2I_1'^3)$ is just the right-hand side of (14.19). By deforming the complex (14.18) to a split complex over \mathbf{P}^1 as in [13, Section 1f)], and using the axiomatic characterization of Bott-Chern classes in [13, Theorem 1.29] as in [13, Corollary 1.30], we get (14.20). □

The term $I_2'^0$

Clearly

$$(14.21) \quad I_2'^0 = - \int_1^{T_0} \Phi \text{Tr}_s \left[N_{(AT)^2}^V \exp(-B_{A,T}'^2) \right] \frac{dT}{T}.$$

$\alpha)$ $A \rightarrow +\infty$

By Theorem 6.6,

$$(14.22) \quad I_2^{I_0} \rightarrow I_2^{I_1} = - \int_1^{T_0} \Phi \operatorname{Tr}_s \left[P_{1/T} N_{\nabla}^X P_{1/T} \exp \left(-\nabla_{1/T}^{H(X, \xi|_X), 2} \right) \right] \frac{dT}{T}.$$

$\beta)$ $T_0 \rightarrow +\infty$

Take $s \in E$. By (6.12)

$$(14.23) \quad \langle P_{1/T} s, P_{1/T} s \rangle_{1/T} = \left\langle \tilde{P}_{1/T} T^{N_H} s, \tilde{P}_{1/T} T^{N_H} s \right\rangle.$$

Since $H(X, \xi|_X) \simeq H(\mathcal{H}, v)$, we can represent any class in $H(X, \xi|_X)$ by $s \in \ker V^{\mathcal{H}}$, so that $s \in \Omega^0(X, \xi_{0|X})$, $\bar{\partial}^X s = 0$, $v^{\mathcal{H}*} = 0$. From (14.23), we get

$$(14.24) \quad \langle P_{1/T} s, P_{1/T} s \rangle_{\frac{1}{T}} = \left\langle \tilde{P}_{1/T} s, \tilde{P}_{1/T} s \right\rangle.$$

Let P_0 be the orthogonal projection operator from E on $\ker V^{\mathcal{H}}$. Using the arguments after (14.14), we find easily that as $T \rightarrow +\infty$, $\tilde{P}_{1/T} = P_0 + \mathcal{O}(\frac{1}{T})$. In particular if s is taken as before,

$$(14.25) \quad \langle P_{1/T} s, P_{1/T} s \rangle_{\frac{1}{T}} = \langle s, s \rangle + \mathcal{O}(\frac{1}{T}).$$

From (14.25), we find that as $T \rightarrow +\infty$,

$$(14.26) \quad g_{1/T}^{H(X, \xi|_X)} = g^{H(\mathcal{H}, v)} + \mathcal{O}(\frac{1}{T}),$$

and so

$$(14.27) \quad \nabla^{H(X, \xi|_X)} = \nabla^{H(\mathcal{H}, v)} + \mathcal{O}(\frac{1}{T}).$$

□

By (14.22), (14.27), we find that as $T_0 \rightarrow +\infty$,

$$(14.28) \quad I_2^{I_1} \rightarrow I_2^{I_2} = - \int_1^{+\infty} \Phi \operatorname{Tr}_s \left[P_{1/T} N_{\nabla}^X P_{1/T} \exp \left(-\nabla_{1/T}^{H(X, \xi|_X), 2} \right) \right] \frac{dT}{T}.$$

$\gamma)$ $\varepsilon \rightarrow 0$

$I_2^{I_2}$ remains constant and equal to $I_2^{I_3}$.

$\delta)$ Evaluation of I_2^3

Proposition 14.2 — *The following identity holds*

$$(14.29) \quad I_2^3 = \frac{1}{2} \tilde{\text{ch}} \left(H(X, \xi_{|X}), g^{H(X, \xi_{|X})}, g^{H(\mathcal{X}, v)} \right) \text{ in } P^S / P^{S,0}.$$

Proof. Since $H(X, \xi_{|X})$ is concentrated is degree 0,

$$(14.30) \quad I_2^1 = - \int_1^{T_0} \Phi \text{Tr}_s \left[P_{1/T} N_{\mathbf{H}} P_{1/T} \exp \left(-\nabla_{1/T}^{H(X, \xi_{|X}), 2} \right) \right] \frac{dT}{T}.$$

□

By (6.49)

$$(14.31) \quad I_2^1 = \frac{1}{2} \tilde{\text{ch}} \left(H(X, \xi_{|X}), g^{H(X, \xi_{|X})}, g_{1/T}^{H(X, \xi_{|X})} \right).$$

Using (14.26), (14.28), (14.31), we get (14.29). □

The term I_3^0

This term was already studied in Section 6.4.

The term I_4^0

We have the identity

$$(14.32) \quad I_4^0 = \int_1^{T_0} \Phi \text{Tr}_s \left[N_{(\varepsilon T)^2}^V \exp(-B_{\varepsilon, T}^{\prime 2}) \right] \frac{dT}{T}.$$

$\alpha)$ $A \rightarrow +\infty$

I_4^0 remains constant and equal to I_4^1 .

$\beta)$ $T_0 \rightarrow +\infty$

By proceeding as in (14.13), we find that as $T_0 \rightarrow +\infty$,

$$(14.33) \quad I_4^1 \rightarrow I_4^2 = \int_1^{+\infty} \Phi \text{Tr}_s \left[N_{(\varepsilon T)^2}^V \exp(-B_{\varepsilon, T}^{\prime 2}) \right] \frac{dT}{T}.$$

$\gamma)$ $\varepsilon \rightarrow 0$

Clearly

$$(14.34) \quad I_4^2 = \int_{\varepsilon}^{+\infty} \Phi \text{Tr}_s \left[N_{T^2}^V \exp(-A_{T, \varepsilon}^2) \right] \frac{dT}{T}.$$

By [14, eq. (2.126)], we know that given $\varepsilon \in [0, 1]$, there are forms $C_{-1}^V(\varepsilon)$, $C_0^V(\varepsilon)$ in P^S , depending smoothly on ε , such that as $T \rightarrow 0$,

$$(14.35) \quad \Phi \operatorname{Tr}_s [N_{T^2}^V \exp(-A_{T,\varepsilon}^2)] = \frac{1}{T^2} C_{-1}^V(\varepsilon) + C_0^V(\varepsilon) + \mathcal{O}_\varepsilon(T^2)$$

and $\mathcal{O}_\varepsilon(T^2)$ is uniform in $\varepsilon \in [0, 1]$. Moreover by [14, Definition 2.25],

$$(14.36) \quad \begin{aligned} C_{-1}^V(\varepsilon) &= \int_X \frac{\omega^V}{2\pi} \operatorname{Td}(TX, g^{TX}) \Phi \operatorname{Tr}_s [\exp(-C_{\varepsilon^2}^2)] , \\ C_0^V(\varepsilon) &= \int_X (\dim X \operatorname{Td}(TX) - \operatorname{Td}'(TX)) \operatorname{ch}(\xi) \text{ in } P^S/P^{S,0}. \end{aligned}$$

In particular the classes of $C_{-1}^V(\varepsilon)$, $C_0^V(\varepsilon)$ in $P^S/P^{S,0}$ do not depend on ε .

Also by proceeding as in (14.13), one can prove that for $\varepsilon \in [0, 1]$, as $T \rightarrow +\infty$, the integrand in (14.34) is uniformly bounded by $\mathcal{O}(\frac{1}{T^3})$. Using (14.35), we find that as $\varepsilon \rightarrow 0$

$$(14.37) \quad \begin{aligned} I_4'^2 - \frac{1}{2} C_{-1}^V(\varepsilon) \frac{1}{\varepsilon^2} + C_0^V(\varepsilon) \log(\varepsilon) &\rightarrow I_4'^3 = \\ &\int_0^1 \Phi \left(\operatorname{Tr}_s [N_{T^2}^V \exp(-A_{T,0}^2)] - \frac{C_{-1}^V(0)}{T^2} - C_0^V(0) \right) \frac{dT}{T} \\ &\quad + \int_1^{+\infty} \Phi \operatorname{Tr}_s [N_{T^2}^V \exp(-A_{T,0}^2)] \frac{dT}{T} - \frac{1}{2} C_{-1}^V(0). \end{aligned}$$

δ) Evaluation of $I_4'^3$

Theorem 14.3 — *The following identity holds*

$$(14.38) \quad I_4'^3 = \frac{1}{2} \left\{ - \sum_{k=0}^m (-1)^k T(\omega^V, g^{\xi_k}) + \Gamma'(1) C_0^V(0) \right\} \text{ in } P^S/P^{S,0}.$$

Proof. The identity (14.38) follows from (2.50) and (14.37). □

The right-hand side of (14.6)

As in Sections 6.7 and 6.8, one establishes the equality

$$(14.39) \quad \sum_1^4 I_k'^4 = \Phi(\bar{\partial}\gamma_4' + \partial\delta_4').$$

Of course, one needs to study in detail the right-hand side of (14.6). The situation being much simpler than in Chapter 6, we leave the details to the reader.

14.3 Matching the divergences

We will only check that the divergences of the I_k^0 's vanish in $P^S/P^{S,0}$. When $A \rightarrow +\infty$ there are no divergences (including in (6.54)), because $H(X, \xi|_X)$ is concentrated in degree 0. When $T_0 \rightarrow +\infty$, no divergence appears. When $\varepsilon \rightarrow 0$, we get the diverging terms in (14.17), (6.55), (14.37) which refer to I_1^2 , I_3^2 and I_4^2

$$(14.40) \quad (-\text{ch}'(\mathcal{H}, g^{\mathcal{H}}) + C_0^V(\varepsilon) - D_0^V) \log(\varepsilon) + \frac{1}{2}(D_{-1}^V - C_{-1}^V(\varepsilon)) \frac{1}{\varepsilon^2}.$$

□

By (2.51), (6.14), (14.36), using the fact that ω^V is closed, (14.40) vanishes in $P^S/P^{S,0}$.

14.4 Proof of Theorem 0.2

By (6.56), (14.20), (14.29), (14.38), the identity (14.39) can be written in the form

$$(14.41) \quad -\frac{1}{2} \tilde{\text{ch}} \left((\mathcal{H}, g^{\mathcal{H}}), \left(H(\mathcal{H}, v), g^{H(\mathcal{H}, v)} \right) \right) + \\ \frac{1}{2} \tilde{\text{ch}} \left(H(X, \xi|_X), g^{H(X, \xi|_X)}, g^{H(\mathcal{H}, v)} \right) + \\ \frac{1}{2} T(\omega^V, g^\xi) - \frac{1}{2} \sum_{k=0}^m (-1)^k T(\omega^V, g^{\xi^k}) + \frac{1}{2} \Gamma'(1) (-\text{ch}'(\mathcal{H}, g^{\mathcal{H}}) \\ + C_0^V(0) - D_0^V) = 0 \text{ in } P^S/P^{S,0}.$$

As we saw in (14.40), the term after $\Gamma'(1)$ in (14.41) vanishes in $P^S/P^{S,0}$. Also by the universality of Bott-Chern classes [13, Section 1f)], using the notation in (0.11), one has the identity

$$(14.42) \quad \tilde{\text{ch}} \left((\mathcal{H}, g^{\mathcal{H}}), \left(H(\mathcal{H}, v), g^{H(\mathcal{H}, v)} \right) \right) - \tilde{\text{ch}} \left(H(X, \xi|_X), g^{H(X, \xi|_X)}, g^{H(\mathcal{H}, v)} \right) \\ = \tilde{\text{ch}} \left(\mathcal{H}, g^{\mathcal{H}} \right) \text{ in } P^S/P^{S,0}.$$

From (14.41), (14.42), we get (0.13).

The proof of Theorem 0.2 is completed. □

15. A new derivation of the asymptotics of the generalized supertraces associated to a short exact sequence

In [6], to a short exact sequence $0 \rightarrow L \rightarrow M \rightarrow N \rightarrow 0$ of holomorphic Hermitian vector bundles, we associated a superconnection \mathfrak{B}_T , whose curvature \mathfrak{B}_T^2 was calculated in [6, Theorem 3.10] and in Theorem 5.6. Also in [6, Theorem 7.7], we established (5.22) in Theorem 5.11, by calculating explicitly the generalized supertraces as infinite determinants.

In [19, Section 14], we briefly sketched another derivation of Theorem 5.11 by showing that as $T \rightarrow +\infty$, the operator $\mathfrak{D}_{T^2}^2$ defined in (5.16) can be written as a $(2, 2)$ matrix whose asymptotic structure is closely related to the matrix structure of $\mathcal{L}_{u,T}^{3,y_0}$ described in Theorem 13.14 (with $\xi^+ = 0$). Still in [19, Section 14], we did not use the fact that $\mathfrak{D}_{T^2}^2$ is itself the square of the superconnection \mathfrak{D}_T introduced in (5.15). Moreover the proof of [19, Section 14] was purely computational.

In this Chapter, we come back again to the problem considered in [6] and in [19, Section 14]. More precisely, we show that if V and W are the total spaces of M and L , and if $i: W \rightarrow V$ is the corresponding embedding, then the superconnection \mathfrak{B}_T is just a special case of $A_{1,\sqrt{T}}$. The superconnection \mathfrak{C}_T is just the analogue of $\tilde{A}_{1,\sqrt{T}}$, and \mathfrak{D}_T is the superconnection $\tilde{A}_{1,\sqrt{T}}$ in the trivialization of Section 13.9. Then we show that the asymptotics of $\mathfrak{D}_{T^2}^2$ obtained in [19, Section 14] is a consequence of Theorems 13.16 and 13.17.

In other words, it should now be clear that the main result of [19, Section 14] should be thought of as the prototype of some of the results we proved in the context of a general family of immersions, for the simplest such family, which is the embedding of L in M .

This Chapter is organized as follows. In Section 15.1, we introduce the family of immersions $i = L \rightarrow M$. In Section 15.2, we construct the superconnections \mathfrak{B}_T , and we relate the conjugate superconnections \mathfrak{C}_T and \mathfrak{D}_T to $\tilde{A}_{1,\sqrt{T}}$.

We use the assumptions and notation of Chapter 5.

15.1 A family of immersions

Let V, W be the total spaces of M, L and let $\pi_V : V \rightarrow B, \pi_W : W \rightarrow B$ be the obvious projections. Then we have the diagram

$$(15.1) \quad \begin{array}{ccc} L & \longrightarrow & W \\ \downarrow & & \downarrow \searrow \pi_W \\ M & \longrightarrow & V \xrightarrow{\pi_V} B \end{array}$$

which is the obvious analogue of (3.1). Moreover, with the notation of Section 3.2,

$$(15.2) \quad N_{W/V} = N|_W .$$

Let z be the generic point of M . Then the Koszul complex $(\pi_V^* \Lambda N^*, \sqrt{-1}i_{j(z)})$ provides a resolution of the sheaf $i_* \mathcal{O}_W$, and restricts fibrewise to a resolution of $i_* \mathcal{O}_L$.

Now we use the notation of Chapter 3, with $\xi = \pi_V^* \Lambda N^*, v = \sqrt{-1}i_{j(z)}$. In particular, if $b \in B, E_b$ denotes the vector space of smooth sections of $\pi_V^*(\Lambda(\overline{M}^*) \widehat{\otimes} \Lambda(N^*))$ along the fibre $M_{\mathbf{R},b}$, and F_b denotes the vector space of smooth sections of $\pi_W^* \Lambda(\overline{L}^*)$ on $L_{\mathbf{R},b}$.

Let $T^H V$ be the horizontal subbundle of TV associated to the connection ∇^M . Using the splitting $TV = T^H V \oplus \pi_V^* M$, we get the identification

$$(15.3) \quad \Lambda(T_{\mathbf{R}}^* V) = \pi_V^* (\Lambda(T_{\mathbf{R}}^* B) \widehat{\otimes} \Lambda(M_{\mathbf{R}}^*)) .$$

Put

$$(15.4) \quad \omega^V = i\bar{\partial}\partial |z|_M^2 .$$

Let ω^M the Kähler form along the fibres of $M_{\mathbf{R}}$. Using (15.3), we see that ω^M can be identified to a real (1, 1) form on V . Then a simple computation shows that

$$(15.5) \quad \omega^V = \omega^M + \frac{i \langle R^M z, \bar{z} \rangle_M}{2} .$$

From (15.5), we see that ω^V restricts to the Kähler form ω^M along the fibres M , and moreover $T^H V$ is exactly the orthogonal bundle to TV with respect to ω^V .

Put

$$(15.6) \quad \omega^W = i^* \omega^V .$$

Then by (15.4),

$$(15.7) \quad \omega^W = i\bar{\partial}\partial |z|_L^2 .$$

Let $T^H W$ be the horizontal subbundle of TW associated to ∇^L . Using the splitting $TW = T^H W \oplus \pi_W^* L$, we get the identification

$$(15.8) \quad \Lambda(T_{\mathbf{R}}^* W) = \pi_W^* (\Lambda(T_{\mathbf{R}}^* B) \widehat{\otimes} \Lambda(L_{\mathbf{R}}^*)) .$$

Then we have the analogue of (15.5), i.e.

$$(15.9) \quad \omega^W = \omega^L + \frac{i \langle R^L z, \bar{z} \rangle_N}{2} .$$

Now to the previous datas on V or W , we can construct the objects which we considered in Chapter 3. In particular if $A, A' \in T_{\mathbf{R}} B, Z \in M_{\mathbf{R}}$,

$$(15.10) \quad T^V(A^{H,V}, A'^{H,V}) = R^M(A, A')Z ,$$

the other components of T^V vanishing identically. Also $\xi = \pi_V^* \Lambda N^*$ is naturally equipped with a Hermitian metric, and the adjoint v^* of $v = \sqrt{-1}i_{j(z)}$ is given by

$$(15.11) \quad v^* = -\sqrt{-1}j(\bar{z})^* \wedge .$$

If $V = v + v^*$, if $Z = z + \bar{z}$, then, with the notation of Section 2.2,

$$(15.12) \quad V = \frac{i\widehat{c}(Z)}{\sqrt{2}} .$$

15.2 The superconnection \mathcal{B}_T

Let $D^M = \bar{\partial}^M + \bar{\partial}^{M*}$ be the obvious Dirac operator acting on E along the fibres of B . In view of (2.31), (4.1), (15.10), the analogue of $A_{1, \sqrt{T}}$, which we note by \mathcal{B}_T , is given by

$$(15.13) \quad \mathcal{B}_T = D^M + \sqrt{T}V + \nabla^E - \frac{c(R^M Z)}{2\sqrt{2}} ,$$

which fits with (5.7).

If $U \in T_{\mathbf{R}} B$, let $U^{H, N_{L/M}}$ be defined as in Definition 1.8. Then one finds easily that on W ,

$$(15.14) \quad U^{H, N_{L/M}} = A(U)Z .$$

If we extend $U^{H, N_{Y/X}}$ to the whole V by formula (7.30), where γ is taken to be 1, we get

$$(15.15) \quad U^{H, N_{L/M}} = A(U)P^L Z .$$

Let ∇ be the trivial connection along the fibres of M . Using (11.32), (15.10), we see that along the fibres of M , we have the identity of connections

$$(15.16) \quad {}^1\nabla\pi_{\check{V}}^*(\Lambda(T_{\mathbb{R}}^*B)\hat{\otimes}\Lambda(\overline{M}^*)) = \nabla + \frac{1}{2} \langle R^M Z, \cdot \rangle .$$

By (15.16), we find that the parallel transport operator τ from $P^L Z$ to Z along $t \in [0, 1] \rightarrow P^L Z + tP^N Z$ with respect to ${}^1\nabla\pi_{\check{V}}^*(\Lambda(T_{\mathbb{R}}^*B)\hat{\otimes}\Lambda(\overline{M}^*))$ is given by

$$(15.17) \quad \tau = \exp \left(\frac{1}{2} \langle R^M P^N Z, P^L Z \rangle \right) .$$

By (11.33), (13.18), (15.15), formula (15.17) also gives the parallel transport operator with respect to ${}^2\nabla\pi_{\check{V}}^*(\Lambda(T_{\mathbb{R}}^*B)\hat{\otimes}\Lambda(\overline{M}^*))$ and ${}^3\nabla\pi_{\check{V}}^*(\Lambda(T_{\mathbb{R}}^*B)\hat{\otimes}\Lambda(\overline{M}^*))$.

By (7.35), (15.15), the analogue of $\tilde{A}_{1,\sqrt{T}}$ is given by

$$(15.18) \quad \mathcal{C}_T = \exp \left(\frac{c(AP^L Z)}{\sqrt{2}} \right) \mathcal{B}_T \exp \left(\frac{-c(AP^L Z)}{\sqrt{2}} \right) .$$

Now in view of (15.17), we see that when trivializing $\pi_{\check{V}}^*\Lambda(\overline{M}^*)$ by parallel transport with respect to ${}^3\nabla\pi_{\check{V}}^*(\Lambda(T_{\mathbb{R}}^*S)\hat{\otimes}\Lambda(\overline{M}^*))$ in the directions of N (which are normal to L), \mathcal{C}_T is replaced by \mathcal{D}_T given by

$$(15.19) \quad \mathcal{D}_T = \exp \left(-\frac{1}{2} \langle R^M P^N Z, P^L Z \rangle \right) \mathcal{C}_T \exp \left(\frac{1}{2} \langle R^M P^N Z, P^L Z \rangle \right) .$$

Equivalently,

$$(15.20) \quad \mathcal{D}_T = \exp \left(\frac{c(AP^L Z)}{\sqrt{2}} - \frac{1}{2} \langle R^M P^N Z, P^L Z \rangle \right) \mathcal{B}_T \exp \left(-\frac{c(AP^L Z)}{\sqrt{2}} + \frac{1}{2} \langle R^M P^N Z, P^L Z \rangle \right) .$$

As the notation indicates, formulas (15.18), (15.20) are compatible with (5.15).

From (15.20), we see that when defining F_T as in (8.8), the expansion as $T \rightarrow +\infty$ of $F_T \mathcal{D}_T F_T^{-1}$ is given by the right-hand side of (13.81).

The analogue of B_1^W is the superconnection on F

$$(15.21) \quad \mathcal{B}_1^W = D^N + \nabla^F - \frac{c(R^N Z)}{2\sqrt{2}} .$$

Then if \mathfrak{C} is given by the analogue of (13.80), by Theorem 13.16,

$$(15.22) \quad \psi^{-1} p \mathfrak{C} p \psi = \mathcal{B}_1^W .$$

Note that in [19, Theorem 14.6], we calculated directly the expansion of \mathcal{D}_T^2 as $T \rightarrow +\infty$, by using (5.16).

In retrospect, formula (5.16) for \mathcal{D}_T^2 and the asymptotic result of [19, Section 14] appear just as special cases of results we proved in full generality for families of immersions.

Remark 15.1. By (15.4), the form ω^V is $\bar{\partial}\partial$ exact. If we use the notation in (7.23), we thus find that even though in general, $T^H W \neq T^H V|_W$,

$$(15.23) \quad \rho([\omega^V]) = 0.$$

This gives a (sophisticate) confirmation to the possibility (exploited in [6]) of deforming the complex (5.1) over \mathbf{P}^1 to a split situation, where $T^H W = T^H V|_W$.

Bibliography

- [1] Atiyah M. F., Bott R., Patodi V. K., On the heat equation and the Index Theorem, *Invent. Math.*, 19 (1973), 279-330.
- [2] Baum P., Fulton W., MacPherson R., Riemann-Roch for singular varieties, *Publ. Math. IHES*, 45 (1975), 101-146.
- [3] Berline N., Getzler E., Vergne M., Heat kernels and Dirac operators, Grundle Math. Wiss. Band 298. Berlin-Heidelberg-New-York, Springer 1992.
- [4] Bismut J.-M., The index Theorem for families of Dirac operators: two heat equation proofs, *Invent. Math.*, 83 (1986), 91-151.
- [5] —————, Superconnection currents and complex immersions, *Invent. Math.*, 99 (1990), 59-113.
- [6] —————, Koszul complexes, harmonic oscillators and the Todd class, *J.A.M.S.*, 3 (1990), 159-256.
- [7] —————, Formules de Lichnerowicz et théorème de l'indice, Proceedings of the Conference in honour of A. Lichnerowicz, D. Bernard, Y. Choquet-Bruhat eds., Vol. Géom. Diff. pp 11-31. Travaux en cours, Paris: Hermann 1988.
- [8] —————, Equivariant short exact sequences of vector bundles and their analytic torsion forms. *Comp. Math.*, 93 (1994), 291-354.
- [9] —————, The infinitesimal Lefschetz formulas: a heat equation proof, *J. Funct. Anal.*, 62 (1985), 435-457.
- [10] —————, Familles d'immersions et formes de torsion analytique en degré supérieur. C.R. Acad. Sci. Paris, 320, série I (1995), 969-974.
- [11] Bismut J.-M., Berthomieu A., Quillen metrics and higher analytic torsion forms, *J. reine angew. Math.*, 457 (1994), 85-184
- [12] Bismut J.-M., Cheeger J., η -invariants and their adiabatic limits, *J.A.M.S.*, 2 (1989), 33-70.
- [13] Bismut J.-M., Gillet H., Soulé C., Analytic torsion and holomorphic determinants bundles, I, *Comm. Math. Phys.*, 115 (1988), 49-78.

- [14] —————, Analytic torsion and holomorphic determinants bundles, II, *Comm. Math. Phys.*, 115 (1988), 79-126.
- [15] —————, Analytic torsion and holomorphic determinants bundles, III, *Comm. Math. Phys.*, 115 (1988), 301-351.
- [16] —————, Bott-Chern currents and complex immersions. *Duke Math. Journal*, 60 (1990), 255-284.
- [17] —————, Complex immersions and Arakelov geometry, *The Grothendieck Festschrift*, P. Cartier and al. eds, pp. 249-331. Prog. Math. n° 86. Boston-Basel-Berlin, Birkhäuser, 1990.
- [18] Bismut J.-M., Köhler K., Higher analytic torsion forms and anomaly formulas, *J. of Alg. Geom.*, 1 (1992), 647-684.
- [19] Bismut J.-M., Lebeau G., Complex immersions and Quillen metrics, *Publ. Math. IHES*, 74 (1991), 1-297.
- [20] Bott R., Chern S. S., Hermitian vector bundles and the equidistribution of the zeros of their holomorphic sections, *Acta Math.*, 114 (1968), 71-112.
- [21] Chazarain J., Piriou A., *Introduction à la théorie des équations aux dérivées partielles linéaires*, Paris, Gauthier-Villars, 1981.
- [22] Faltings G., *Lectures on the arithmetic Riemann-Roch theorem*, Ann. Math. Studies, Princeton University Press, Princeton 1992
- [23] Getzler E., A short proof of the Atiyah-Singer Index Theorem, *Topology*, 25 (1986), 111-117.
- [24] Gillet H., Soulé C., Arithmetic Intersection Theory, *Publ. Math. IHES*, 72 (1990), 93-174.
- [25] —————, Characteristic classes of algebraic vector bundles with Hermitian metric, *Ann. of Math.*, I, 131 (1990), 163-203, II, 131 (1990), 205-238.
- [26] —————, Analytic torsion and the arithmetic Todd genus, *Topology*, 30 (1991), 21-54.
- [27] —————, An arithmetic Riemann-Roch Theorem, *Invent. Math.*, 110 (1992), 473-543.
- [28] Griffiths P., Harris J., *Principles of algebraic geometry*, New-York, Wiley, 1978.
- [29] Hitchin N.: Harmonic spinors, *Adv. Math.*, 14 (1974), 1-55
- [30] Hörmander L., *The analysis of linear partial differential operators*, I, Grundle Math. Wiss. Band 256, Berlin-Heidelberg-New-York, Springer, 1983.
- [31] Kobayashi S., *Differential geometry of complex vector bundles*. Iwanami Shoten and Princeton University Press, 1987.

- [32] Quillen D., Superconnections and the Chern character, *Topology*, 24 (1985), 89-95.
- [33] —————, Determinants of Cauchy-Riemann operators over a Riemann surface, *Funct. Anal. Appl.*, 14 (1985), 31-34.
- [34] Ray D. B., Singer I., Analytic torsion for complex manifolds, *Ann. of Math.*, 98 (1973), 154-177.
- [35] Taylor M., *Pseudodifferential operators*, Princeton, Princeton Univ. Paris, 1981.

Jean-Michel Bismut
Département de Mathématique,
Université Paris-Sud
Bâtiment 425, 91405 Orsay Cedex, France
bismut@topo.math.u-psud.fr