

# ANNALES DE L'I. H. P., SECTION A

A. BASSETTO

M. TOLLER

## **Harmonic analysis on the one-sheet hyperboloid and multiperipheral inclusive distributions**

*Annales de l'I. H. P., section A*, tome 18, n° 1 (1973), p. 1-38

[http://www.numdam.org/item?id=AIHPA\\_1973\\_\\_18\\_1\\_1\\_0](http://www.numdam.org/item?id=AIHPA_1973__18_1_1_0)

© Gauthier-Villars, 1973, tous droits réservés.

L'accès aux archives de la revue « Annales de l'I. H. P., section A » implique l'accord avec les conditions générales d'utilisation (<http://www.numdam.org/conditions>). Toute utilisation commerciale ou impression systématique est constitutive d'une infraction pénale. Toute copie ou impression de ce fichier doit contenir la présente mention de copyright.

NUMDAM

Article numérisé dans le cadre du programme  
Numérisation de documents anciens mathématiques

<http://www.numdam.org/>

## Harmonic analysis on the one-sheet hyperboloid and multiperipheral inclusive distributions

by

A. BASSETTO and M. TOLLER

C. E. R. N., Geneva

---

**ABSTRACT.** — The harmonic analysis of the  $n$  particle inclusive distributions and the partial diagonalization of the ABFST multiperipheral integral equation at vanishing momentum transfer are treated rigorously on the basis of the harmonic analysis of distributions defined on the one-sheet hyperboloid in four dimensions. A complete and consistent treatment is given of the Radon and Fourier transforms on the hyperboloid and of the diagonalization of invariant kernels. The final result is a special form of the  $O(3, 1)$  expansion of the inclusive distributions, which exhibits peculiar dynamical features, in particular fixed poles at the nonsense points, which are essential in order to get the experimentally observed behaviour.

**RÉSUMÉ.** — Nous traitons rigoureusement la diagonalisation partielle de l'équation intégrale multipériphérique de ABFST à valeur nulle de l'impulsion transférée et l'analyse harmonique des distributions inclusives à  $n$  particules, faisant recours à des résultats mathématiques concernant l'analyse harmonique sur un hyperboloïde à une nappe en quatre dimensions. Nous donnons un traitement complet des transformations de Radon et de Fourier sur l'hyperboloïde et de la diagonalisation des noyaux invariants. Le résultat final est une forme particulière de développement selon  $O(3, 1)$  des distributions inclusives, qui met en évidence des caractéristiques dynamiques particulières, notamment des pôles fixes aux points de « non sens », qui sont nécessaires pour obtenir un accord avec des propriétés bien établies par l'expérience.

### 1. Introduction

In the present paper we develop and clarify some mathematical procedures which are useful for the treatment of multiperipheral models of the ABFST type ([1]-[3]). These models provide a definite approxi-

mate expression for the  $N$  particle production amplitudes. By integrating over all the final states, one gets the total cross-sections; if one keeps some of the final momenta fixed, integrating over all the other momenta and summing over the multiplicity  $N$ , one obtains the inclusive distributions ([1], [4]-[7]). It is just in dealing with this last aspect of the model that the powerful mathematical concepts described in the following are most useful.

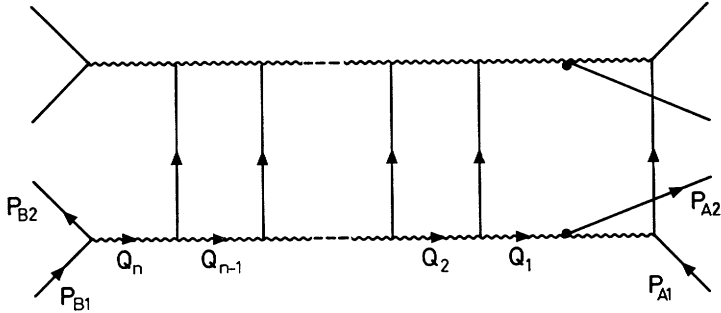

Fig. 1. — A multiperipheral contribution to the two-particle inclusive distribution. Wavy lines represent off-shell spinless particles and solid lines represent on-shell particles. On-shell integration is understood for internal solid lines. The upper part of the graph represents just the complex conjugate of the production amplitude represented by the lower part.

In the simplest version of the model, the production amplitudes are given by the multiperipheral graphs of a  $\varphi^3$  field theory. In this case in computing a two-particle inclusive distribution we find, for instance, an integral of the kind described by the graph in figure 1. It has the general form

$$(1.1) \quad \mathcal{J}_n(P_B, P_A) = \int \dots \int f_B(P_B, Q_n) K(Q_n, Q_{n-1}) \dots \\ \times K(Q_2, Q_1) f_A(P_A, Q_1) d^4 Q_1 \dots d^4 Q_n,$$

where  $P_A$  stands for  $P_{A1}, P_{A2}, \dots$  and  $P_B$  has a similar meaning.

For instance, in the example of figure 1, we have

$$(1.2) \quad \left\{ \begin{array}{l} f_B(P_B, Q_n) = (2\pi)^{-1} g^2 \delta^4(Q_n - P_{B1} + P_{B2}) (Q_n^2 - m^2)^{-2}, \\ K(Q_{i+1}, Q_i) = (2\pi)^{-3} g^2 \delta((Q_{i+1} - Q_i)^2 - m^2) \\ \quad \times \theta(Q_{i+1,0} - Q_{i0}) (Q_i^2 - m^2)^{-2}, \\ f_A(P_A, Q_1) = (2\pi)^4 g^4 \delta((Q_1 - P_{A2} + P_{A1})^2 - m^2) \\ \quad \times \theta(Q_{1,0} - P_{A2,0} + P_{A1,0}) ((Q_1 - P_{A2})^2 - m^2)^{-2}. \end{array} \right.$$

One can easily realize that also other contributions to the inclusive distribution in the  $\varphi^3$  model have the form (1.1) with more complicated forms for the functions  $f_A$  and  $f_B$  when the observed particles are "internal" in the multiperipheral chain.

Also more general multiperipheral models give rise to contributions of the form (1.1). For instance, every term  $K$  could describe the production of a cluster of final particles ([1], [8], [9]). The only limitation of the present treatment is that the wavy lines in figure 2 must represent

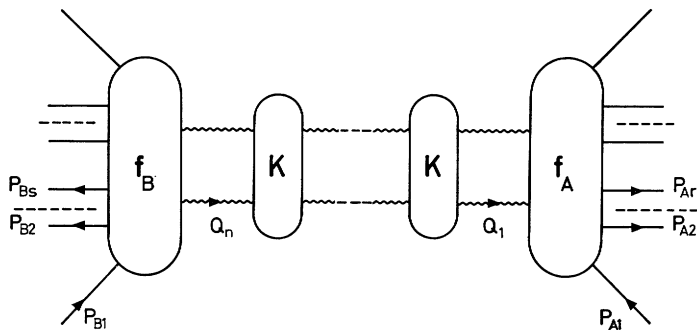

Fig. 2. — A multiperipheral contribution to the  $r + s - 2$  particle inclusive distribution.

spinless off-shell particles. A further generalization leads to the Reggeized multiperipheral models ([10]-[13]), which require more powerful mathematics. Nevertheless, most interesting features appear already in the simpler class of models we are considering.

Our treatment uses only some very general assumptions on the quantities  $K$ ,  $f_A$  and  $f_B$ . From the example (1.2), we see that in general they are Lorentz invariant positive distributions, i. e., Lorentz invariant measures. The integral (1.1) is not necessarily meaningful for every choice of these measures. We shall discuss later how and under which conditions we can give a meaning to this expression.

An essential use will be made of the support properties of these distributions. As  $Q_{i+1} - Q_i$  is just the total four-momentum of a cluster of produced particles, the support of  $K(Q_{i+1}, Q_i)$  is necessarily contained in the region

$$(1.3) \quad (Q_{i+1} - Q_i)^2 \geq M^2, \quad Q_{i+1,0} - Q_{i,0} \geq M,$$

where  $M$  is the sum of the masses of the particles produced in the cluster.

In a similar way we see that the support of  $f_A(P_A, Q_1)$  is contained in

$$(1.4) \quad (P_{A1} + Q_1)^2 \geq M_A^2, \quad Q_{1,0} \geq M_A - P_{A1,0}$$

and the support of  $f_B(P_B, Q_n)$  is contained in

$$(1.5) \quad (-Q_n + P_{B1})^2 \geq M_B^2, \quad -Q_{n0} \geq M_B - P_{B1,0},$$

where  $M_A$  is the sum of the masses of the observed and the unobserved produced particles taken into account by the term  $f_A$ , and  $M_B$  is defined in a similar way. All these inequalities restrict the region of integration in equation (1.1) to a compact set  $\mathcal{K}$ .

We call  $m_{A1}$  and  $m_{B1}$  the masses of the incoming particles and we make the assumption, valid in the most interesting cases,

$$(1.6) \quad M_A \geq m_{A1}, \quad M_B \geq m_{B1} \quad (n \geq 1).$$

Excluding the case in which all the three relations are equalities, a simple reasoning shows that in the set  $\mathcal{K}$  we have

$$(1.7) \quad Q_i^2 < 0 \quad (i = 1, 2, \dots, n)$$

and we can introduce the variables

$$(1.8) \quad u_i = -Q_i^2 > 0, \quad x_i = u_i^{-1/2} Q_i.$$

The four-vectors  $x_i$  span the one sheet hyperboloid  $\Gamma$  defined by

$$(1.9) \quad (x, x) = x^2 = -1.$$

If we introduce the Lorentz invariant measure on  $\Gamma$ :

$$(1.10) \quad d\Gamma = 2 \delta(x^2 + 1) d^4x,$$

equation (1.1) takes the form

$$(1.11) \quad \mathcal{J}_n(P_B, P_A) = \int f_B(P_B, u_n, x_n) K(u_n, x_n, u_{n-1}, x_{n-1}) \dots \\ \times K(u_2, x_2, u_1, x_1) f_A(P_A, u_1, x_1) \\ \times \frac{1}{2} u_1 du_1 d\Gamma_1 \dots \frac{1}{2} u_n du_n d\Gamma_n.$$

We remark that perhaps the most important application of multiperipheral models is the study of Regge-like limits. In our case this means ([14]-[16]) to study the dependence of the quantity

$$(1.12) \quad \sum_{n=1}^{\infty} \mathcal{J}_n(L(a)P_B, P_A) = \sum_{n=1}^{\infty} \mathcal{J}_n(a) = \mathcal{J}(a),$$

on the element  $a$  of the Lorentz group acting on all the four-momenta  $P_{Bi}$ , while the four-momenta  $P_{Ai}$  are kept fixed. It is just in the limit of large  $a$  that the separation of the observed particles into two sets A and B becomes natural and unambiguous.

Therefore we are led to consider integrals of the kind

$$(1.13) \quad \mathcal{J}_n(a) = \int f_B(L(a^{-1})x_n) K(x_n, x_{n-1}) \dots \\ \times K(x_2, x_1) f_A(x_1) d\Gamma_1 \dots d\Gamma_n,$$

where the dependence on the variables  $u_i$  is understood and the corresponding integrations are supposed to be performed later. We are assuming that the kernel  $K$  is defined as a Lorentz invariant distribution in  $x_{i+1}, x_i$  for any positive values of  $u_{i+1}$  and  $u_i$ . From now on, the variables  $u_i$  are considered as fixed and we concentrate our attention on the "angular" variables  $x_i$ .

From equation (1.3), one can see that the support of the kernel  $K(x_{i+1}, x_i)$  is contained in the set

$$(1.14) \quad \left\{ \begin{array}{l} - (x_{i+1}, x_i) \geq \frac{1}{2} (u_{i+1} u_i)^{-1/2} (M^2 + u_{i+1} + u_i) > 1, \\ x_{i+1,0} - x_{i0} > 0; \end{array} \right.$$

while from equations (1.4) and (1.5) we see that the supports of  $f_A(x_i)$  and  $f_B(x_n)$  are contained in the sets

$$(1.15) \quad x_{1,0} \geq u_1^{-1/2} (M_A - P_{A1,0})$$

and

$$(1.16) \quad -x_{n0} \geq u_n^{-1/2} (M_B - P_{B1,0})$$

respectively.

These are the support properties on which we rely in the following. Though only positive measures appear in the physical problem, from a mathematical point of view it is natural to deal with arbitrary distributions with some limitation on their rate of increase. This is the point of view we shall adopt.

We shall show in Section 9 that if  $K, f_A$  and  $f_B$  have the support properties mentioned above, the integral (1.13) can be interpreted as a distribution on the Lorentz group. Assuming some limitation on the rate of growth of these distributions, we shall give an expansion of the quantity (1.13) in terms of matrix elements of irreducible, not necessarily unitary, representations of the Lorentz group. This expansion has not exactly the form proposed in [17] and it exhibits some peculiarities hitherto unexplored, as the existence of fixed poles at the "Lorentz nonsense" points. The existence of these poles is essential for a correct approach to the transverse momentum dependence of the inclusive distributions [7].

We shall get these results following the classical procedure of distribution theory [18]. First we perform the harmonic analysis of a function belonging to the space  $\omega(\Gamma)$  of the infinitely differentiable functions of compact support on the hyperboloid  $\Gamma$ . This can be done by means of the elegant method developed by Gel'fand and collaborators [19]. Unfortunately in [19] only functions with the symmetry property

$$(1.17) \quad f(-x) = f(x),$$

are treated and the extension to the general case is not trivial. The general treatment of the Fourier transform is given in Sections 2 and 3, where we introduce also the usual basis labelled by the angular momentum indices  $j, m$ . Some useful properties of the "hyperbolic harmonics" in this basis are given in Section 4. The inverse formula for functions in  $\omega(\Gamma)$  is given in Section 5.

In Section 6, we introduce some new spaces of test functions and of distributions on the hyperboloid  $\Gamma$  and we define the Laplace transform for a large class of distributions on  $\Gamma$ , in perfect analogy with the Laplace transform of a distribution on the real line [18]. In Section 7 we consider invariant distribution kernels, which have the property of mapping into themselves some spaces of test functions and of distributions on  $\Gamma$ . We show also that when one of these kernels operates on a distribution on  $\Gamma$ , its Laplace transform is changed by a scalar factor; this is just the diagonalization of the kernel. In Section 8 we study the regularization of a distribution on  $\Gamma$  by means of the convolution with a smooth function on the Lorentz group and the corresponding change in its Laplace transform. All these results are applied in Section 9 to derive an  $O(3, 1)$  representation for the inclusive distributions.

In our effort towards a systematic treatment, we partially overlap with previous work. The "hyperbolic harmonics" in a somewhat different form are discussed in [20]. The diagonalization of invariant kernels is treated in ([21], [22]); an extension to spinning particles is given in [23]. These treatments are not based on the harmonic analysis of functions on the hyperboloid, which in our opinion is the most natural and clarifying starting point.

It is also interesting to compare the diagonalization procedure for the multiperipheral equation (giving the absorptive part of the amplitude) with the analogous treatment of the Bethe-Salpeter equation at fixed four-momentum transfer (which gives the whole amplitude). For spacelike four-momentum transfer, the  $O(2, 1)$  projection of the Bethe-Salpeter equation was performed in [24] (see also [25], [26]). Of course, in this case one has no support conditions of the kind (1.3)-(1.5). Instead one has a symmetry with respect to time reversal, which is incompatible with the mentioned support conditions. In this situation, it is una-

voidable to obtain a Laplace transform which has a symmetry property in the  $l$  plane which prevents this transform from being analytic in a half plane. This feature complicates somehow the discussion of the inverse formula, which is nevertheless perfectly justified, at least when only poles are present in the  $l$  plane. If one tries to extend this formalism to the Bethe-Salpeter equation at vanishing four-momentum, one runs into difficulties whose origin will be clear in Section 7.

## 2. The Radon transform

Our first task is to define the Fourier transform of a function  $f(x)$  belonging to the space  $\mathcal{O}(\Gamma)$  of the  $C^\infty$  functions with compact support on the hyperboloid  $\Gamma$  defined by equation (1.9). We follow the method of [19], where this problem is solved for functions which satisfy the symmetry condition (1.17). For some details and for geometrical motivations, [19] should be consulted.

The first step is to define the Radon transforms

$$(2.1) \quad h(\xi) = 2 \int f(x) \delta((x, \xi) + 1) d\Gamma,$$

where the four-vector  $\xi$  belongs to the half cone

$$(2.2) \quad \xi^2 = 0, \quad \xi_0 > 0,$$

and

$$(2.3) \quad \varphi(b, \xi) = \int_{-\infty}^{+\infty} f(b + t\xi) dt,$$

where

$$(2.4) \quad b^2 = -1 \quad (b, \xi) = 0, \quad \xi^2 = 0, \quad \xi_0 > 0.$$

The invariant measure  $d\Gamma$  is defined by equation (1.10).

The function (2.3) has the property

$$(2.5) \quad \varphi(b + \alpha\xi, \beta\xi) = \beta^{-1} \varphi(b, \xi).$$

The Radon transforms  $h(\xi)$  and  $\varphi(b, \xi)$  are infinitely differentiable.  $h(\xi)$  vanishes in a neighbourhood of the origin and  $h(t\xi)$  has at infinity an asymptotic expansion in terms of negative integral powers of  $t$  [19].

Now we want to reconstruct the function  $f(x)$  starting from its Radon transforms. We consider the integral [19] :

$$(2.6) \quad J_+(x, b, \mu) = \int [(b, \xi)]_+^\mu \delta((x, \xi) - 1) \xi_0^{-1} d^3 \xi \quad (\Re \mu < -1),$$



where the distribution  $[f]_{\pm}^{\mu}$  is defined by

$$(2.7) \quad [f]_{\pm}^{\mu} = \lim_{\varepsilon \rightarrow 0} (2i \sin \pi \mu)^{-1} [\exp(i \pi \mu) (t - i \varepsilon)^{\mu} - \exp(-i \pi \mu) (t + i \varepsilon)^{\mu}].$$

Then from equation (2.1) we have <sup>(1)</sup> :

$$(2.8) \quad 2 \int \left[ J_{+}(-x, x - x', \mu) - \frac{1}{2}(\mu + 2) J_{+}(-x, x - x', \mu + 1) \right] f(x) d\Gamma \\ = \int \left( [- (x', \xi) - 1]_{\pm}^{\mu} - \frac{1}{2}(\mu + 2) [- (x', \xi) - 1]_{\pm}^{\mu+1} \right) h(\xi) \xi_0^{-1} d^3 \xi.$$

The function (2.6) has been computed in [19], and, if we put

$$(2.9) \quad k = - (x, x'),$$

we have

$$(2.10) \quad \left\{ \begin{aligned} & J_{+}(-x, x - x', \mu) - \frac{1}{2}(\mu + 2) J_{+}(-x, x - x', \mu + 1) \\ & = -2\pi (k^2 - 1)^{-1/2} \theta(x_0 - x'_0) \\ & \quad \times \left[ (\mu + 1)^{-1} (\sqrt{k^2 - 1} + k - 1)^{\mu+1} \right. \\ & \quad \left. - \frac{1}{2} (\sqrt{k^2 - 1} + k - 1)^{\mu+2} \right] \\ & \quad (k > 1), \end{aligned} \right.$$

$$(2.11) \quad \left\{ \begin{aligned} & J_{+}(-x, x - x', \mu) - \frac{1}{2}(\mu + 2) J_{+}(-x, x - x', \mu + 1) \\ & = \pi (\sin \pi \mu)^{-1} (1 - k^2)^{-1/2} \\ & \quad \times \left[ (\mu + 1)^{-1} (1 - k + i\sqrt{1 - k^2})^{\mu+1} \right. \\ & \quad + (\mu + 1)^{-1} (1 - k - i\sqrt{1 - k^2})^{\mu+1} \\ & \quad \left. + \frac{1}{2} (1 - k + i\sqrt{1 - k^2})^{\mu+2} + \frac{1}{2} (1 - k - i\sqrt{1 - k^2})^{\mu+2} \right] \\ & \quad (|k| < 1), \end{aligned} \right.$$

$$(2.12) \quad \left\{ \begin{aligned} & J_{+}(-x, x - x', \mu) - \frac{1}{2}(\mu + 2) J_{+}(-x, x - x', \mu + 1) = 0 \\ & \quad (k < -1). \end{aligned} \right.$$

<sup>(1)</sup> The integral (2.6) and the integral in the right-hand side of equation (2.8) are not absolutely convergent for large  $\xi$ . They have to be regularized by analytic continuation from the region where  $b$  and  $x'$  respectively are timelike [19].

Both sides of equation (2.8) have a pole at  $\mu = -3$ . Using the equations [18] :

$$(2.13) \quad \begin{cases} \operatorname{res}_{\mu=-3} [t]_{+}^{\mu} = \frac{1}{2} \delta''(t), \\ \operatorname{res}_{\mu=-2} [t]_{+}^{\mu} = -\delta'(t); \end{cases}$$

we see that the residue of the right-hand side is

$$(2.14) \quad \frac{1}{2} \int \left[ \delta''((x', \xi) + 1) + \delta'((x', \xi) + 1) \right] h(\xi) \xi_0^{-1} d^3 \xi.$$

In order to compute the residue of the left-hand side of equation (2.8), we treat separately the regions of integration where equations (2.10) and (2.11) respectively hold. In the first region the singularity comes from a divergence of the integrand at  $k = 1$ . From equation (2.10) we have

$$(2.15) \quad J_{+}(-x, x - x', \mu) - \frac{1}{2}(\mu + 2) J_{+}(-x, x - x', \mu + 1) \\ = -2\pi(\mu + 1)^{-1} \theta(x_0 - x'_0)(k^2 - 1)^{(1/2)\mu} + O[(k^2 - 1)^{(1/2)\mu+1}].$$

We remark that the second term in the left-hand side of this equation is essential in order to cancel a term of the order  $(k^2 - 1)^{\frac{\mu+1}{2}}$  which would also be divergent in the limit  $\mu \rightarrow -3$ .

We choose a frame of reference in which

$$(2.16) \quad \begin{cases} x' = (0, 0, 0, 1), \\ k = x_3, \\ k^2 - 1 = x_0^2 - x_1^2 - x_2^2 \end{cases}$$

and using the formula [18] :

$$(2.17) \quad \operatorname{res}_{\mu=-3} [x_0^2 - x_1^2 - x_2^2]_{+}^{(1/2)\mu} \theta(x_0) = -2\pi \delta(x_0) \delta(x_1) \delta(x_2),$$

we can write the contribution of the region  $k > 1$  to the residue in the form

$$(2.18) \quad \operatorname{res}_{\mu=-3} 2\pi \int \theta(x_0) [x_0^2 - x_1^2 - x_2^2]_{+}^{(1/2)\mu} f(x) dx_0 dx_1 dx_2 = -4\pi^2 f(x').$$

The contribution to the residue of the region  $|k| < 1$  is

$$(2.19) \quad - \int (1 - x_3^2)^{-1/2} (1 - x_3)^{-1} \theta(1 - x_3^2) f(x) d\Gamma.$$

Remark that this integral has to be regularized. We perform the change of variables

$$(2.20) \quad \begin{cases} x_0 = t, \\ x_1 = \sin \theta \sin \alpha + t \cos \alpha, \\ x_2 = -\sin \theta \cos \alpha + t \sin \alpha, \\ x_3 = \cos \theta; \end{cases}$$

$$(2.21) \quad d\Gamma = dt d \cos \theta dx,$$

and the integral (2.19) takes the form

$$(2.22) \quad \begin{aligned} & - \int_{-1}^{+1} d \cos \theta \int_0^{2\pi} dx \int_{-\infty}^{+\infty} dt (\sin \theta)^{-1} (1 - \cos \theta)^{-1} f(b + t \xi) \\ & = - \int_{-1}^{+1} d \cos \theta \int_0^{2\pi} dx (\sin \theta)^{-1} (1 - \cos \theta)^{-1} \varphi(b, \xi). \end{aligned}$$

We have used equation (2.3) and we have put

$$(2.23) \quad \begin{cases} b = (0, \sin \theta \sin \alpha, -\sin \theta \cos \alpha, \cos \theta), \\ \xi = (1, \cos \alpha, \sin \alpha, 0). \end{cases}$$

In order to write equation (2.22) in invariant form, we remark that the argument  $b$  depends only on  $\xi$  and  $\cos \theta$ . If we introduce the differential form on the cone

$$(2.24) \quad \omega = |\xi_0|^{-1} (\xi_1 d\xi_2 d\xi_3 - \xi_2 d\xi_1 d\xi_3 + \xi_3 d\xi_1 d\xi_2),$$

the integral (2.22) can be written in the form

$$(2.25) \quad - \int_{-1}^{+1} (\sin \theta)^{-1} (1 - \cos \theta)^{-1} d \cos \theta \int_{\gamma} \omega_{\delta}((x', \xi)) \varphi(b, \xi).$$

This can easily be shown if  $\gamma$  is the intersection of the cone with the plane  $\xi_0 = 1$ . On the other hand, using equation (2.5) one can show that the integral does not change if  $\gamma$  is deformed in such a way that it still cuts all the generators of the cone.

In conclusion, equating the residues at  $\mu = -3$  of the two sides of equation (2.8), which have been computed in equations (2.14), (2.18)

and (2.25), we get the result

PROPOSITION 1. — *If  $f(x) \in \mathcal{O}(\Gamma)$ , its Radon transforms (2.1) and (2.3) can be inverted by means of the formula*

$$(2.26) \quad f(x') = - (8 \pi^2)^{-1} \int [\delta''((x', \xi) + 1) + \delta'((x', \xi) + 1)] h(\xi) \xi_0^{-1} d^3 \xi \\ - (2 \pi)^{-2} \int_{-1}^{+1} (\sin \theta)^{-1} (1 - \cos \theta)^{-1} d \cos \theta \\ \times \int_{\Upsilon} \omega \delta((x', \xi)) \varphi(b, \xi),$$

where the four-vector  $b$  is determined up to the addition of an irrelevant four-vector proportional to  $\xi$  by the conditions

$$(2.27) \quad b^2 = -1, \quad (b, \xi) = 0, \quad (b, x') = -\cos \theta.$$

A further ambiguity is due to the fact that the condition (2.27) is quadratic. It has to be eliminated by means of an arbitrary but continuous choice.

Of course, as these formulae are written in a Lorentz invariant form, they hold also if  $x'$  has not the special form (2.16).

### 3. The Fourier transform

We assume that the element  $a$  of  $SL(2, C)$  acts on the function  $f$  in the following way <sup>(2)</sup> :

$$(3.1) \quad f(x) \rightarrow [U(a)f](x) = f(L(a^{-1})x).$$

The matrix  $L(a)$  is defined in such a way that the relation

$$(3.2) \quad x' = L(a)x$$

is equivalent to

$$(3.3) \quad \begin{pmatrix} x'_0 + x'_3 & x'_1 - ix'_2 \\ x'_1 + ix'_2 & x'_0 - x'_3 \end{pmatrix} = a \begin{pmatrix} x_0 + x_3 & x_1 - ix_2 \\ x_1 + ix_2 & x_0 - x_3 \end{pmatrix} a^+.$$

It follows that the functions defined in equations (2.1) and (2.3) transform in the following way

$$(3.4) \quad h(\xi) \rightarrow [U(a)h](\xi) = h(L(a^{-1})\xi),$$

$$(3.5) \quad \varphi(b, \xi) \rightarrow [U(a)\varphi](b, \xi) = \varphi(L(a^{-1})b, L(a^{-1})\xi).$$

---

<sup>(2)</sup> For simplicity of notation we indicate by the same symbol  $U(a)$  the representation operators which act on all the function spaces we shall define.

If we put

$$(3.6) \quad h(\xi) = \tilde{h}(z_1, z_2),$$

where

$$(3.7) \quad \begin{pmatrix} \xi_0 + \xi_3 & \xi_1 - i\xi_2 \\ \xi_1 + i\xi_2 & \xi_0 - \xi_3 \end{pmatrix} = 2 \begin{pmatrix} z_2 \\ -z_1 \end{pmatrix} (\bar{z}_2 - \bar{z}_1),$$

the transformation property (3.4) becomes

$$(3.8) \quad [U(a) \tilde{h}](z_1, z_2) = \tilde{h}(z'_1, z'_2),$$

where

$$(3.9) \quad \begin{cases} z'_1 = z_1 a_{11} + z_2 a_{21}, \\ z'_2 = z_1 a_{12} + z_2 a_{22}. \end{cases}$$

The function (3.6) has the symmetry property

$$(3.10) \quad \tilde{h}(e^{i\varphi} z_1, e^{i\varphi} z_2) = \tilde{h}(z_1, z_2).$$

We introduce the new functions

$$(3.11) \quad \tilde{H}^\lambda(z_1, z_2) = (2\pi)^{-1} \int_0^\infty \tilde{h}(tz_1, tz_2) t^{1-2\lambda} dt,$$

which have the homogeneity property

$$(3.12) \quad \tilde{H}^\lambda(\alpha z_1, \alpha z_2) = |\alpha|^{2\lambda-2} \tilde{H}^\lambda(z_1, z_2)$$

for arbitrary complex  $\alpha$ . The integral (3.11) converges for  $\operatorname{Re} \lambda > 0$  and, using the asymptotic expansion of  $h(\xi)$ , it can be analytically continued in the whole complex  $\lambda$  plane apart from poles at  $\lambda = 0, -1, -2, \dots$

In ([19], [27]), the irreducible representations  $T^{n_1, n_2}$  of  $SL(2, \mathbb{C})$  are defined as operators acting on a space of homogeneous functions of  $z_1, z_2$ . We shall use the slightly different notation  $\mathcal{O}^{\mathbb{M}, \lambda}$  where

$$(3.13) \quad n_1 = \lambda - M, \quad n_2 = \lambda + M.$$

Comparing the formulae given above with the definition of ([19], [27]), we see immediately that if  $f(x)$  undergoes the transformation (3.1), the function  $\tilde{H}^\lambda(z_1, z_2)$  transforms according to the representation  $\mathcal{O}^{\mathbb{M}, \lambda}$ .

It is also useful to consider these representations as operators acting on a space of functions on the group  $SU(2)$ . We put

$$(3.14) \quad H^\lambda(u) = \tilde{H}^\lambda(u_{21}, u_{22}) \quad [u \in SU(2)].$$

From equations (3.6), (3.7) and (3.11), we get

$$(3.15) \quad H^\lambda(u) = (2\pi)^{-1} \int_0^\infty h(t^2 L(u^{-1}) \tilde{\xi}) t^{1-2\lambda} dt,$$

where

$$(3.16) \quad \tilde{\xi} = (1, 0, 0, 1).$$

Introducing equation (2.1) we obtain

$$(3.17) \quad H^\lambda(u) = (2\pi)^{-1} \int f(x) [- (x, L(u^{-1}) \tilde{\xi}) ]_+^{\lambda-1} d\Gamma.$$

The transformation property of the function (3.14) is just the one described in ([27]-[29]). As in these references, we introduce in the space of the functions on SU(2) the basis

$$(3.18) \quad (2j + 1)^{1/2} R_{Mm}^j(u),$$

where  $R_{Mm}^j(u)$  are the rotation matrices as defined in [30]. We define the projections

$$(3.19) \quad H_{jm}^\lambda = (2j + 1)^{1/2} \int_{\text{SU}(2)} \overline{R_{0m}^j(u)} H^\lambda(u) d^3 u.$$

Remark that only basis functions with  $M = 0$  appear. Taking into account equation (3.17) we get

$$(3.20) \quad H_{jm}^\lambda = (-1)^m \int B_{j,-m}^{-\lambda}(x) f(x) d\Gamma,$$

where

$$(3.21) \quad B_{jm}^\lambda(x) = (2\pi)^{-1} (2j + 1)^{1/2} \times \int_{\text{SU}(2)} [- (x, L(u^{-1}) \tilde{\xi}) ]_+^{-\lambda-1} R_{0m}^j(u) d^3 u.$$

Remark that if  $\lambda$  is pure imaginary, we have

$$(3.22) \quad (-1)^m B_{j,-m}^{-\lambda}(x) = \overline{B_{jm}^\lambda(x)}.$$

In order to compute the “ hyperbolic harmonics ” (3.21), we introduce angular variables putting

$$(3.23) \quad x = L(u_z(\varphi) u_y(\theta)) \tilde{x}, \quad \tilde{x} = (\text{sh } \alpha, 0, 0, \text{ch } \alpha).$$

Using the invariance of the measure  $d^3 u$  and the definition [30] :

$$(3.24) \quad Y_{jm}(\theta, \varphi) = (4\pi)^{-1/2} (2j + 1)^{1/2} R_{0m}^j(u_y(-\theta) u_z(-\varphi))$$

of spherical harmonics, we get

$$(3.25) \quad B_{jm}^\lambda(x) = Y_{jm}(\theta, \varphi) b_j^\lambda(\alpha),$$

where

$$(3.26) \quad b_j^\lambda(\alpha) = (4\pi)^{-1/2} \int_{-1}^{+1} [- \text{sh } \alpha + \text{ch } \alpha \cos \gamma ]_+^{-\lambda-1} P_j(\cos \gamma) d \cos \gamma.$$

This integral can be performed by means of equation (3.7.30) of [31] (hereafter called HTF) obtaining

$$(3.27) \quad b_j^\lambda(\alpha) = (4\pi)^{-1/2} \Gamma(-\lambda) (\operatorname{ch} \alpha)^{-1} \mathbf{P}_j^\lambda(\operatorname{th} \alpha).$$

In order to Fourier analyze the function (2.3), we consider the function

$$(3.28) \quad \hat{\varphi}(a) = \varphi(L(a^{-1})\tilde{b}, L(a^{-1})\tilde{\xi}) \quad [a \in \operatorname{SL}(2, \mathbb{C})],$$

where

$$(3.29) \quad \tilde{\xi} = (1, 0, 0, 1), \quad \tilde{b} = (0, 1, 0, 0).$$

If we put

$$(3.30) \quad k = \begin{pmatrix} p^{-1} & q \\ 0 & p \end{pmatrix} \quad (\operatorname{Im} p = 0),$$

using the property (2.5), we see that

$$(3.31) \quad \hat{\varphi}(ka) = p^{-2} \hat{\varphi}(a).$$

In particular, we see that  $\hat{\varphi}(a)$  depends only on

$$(3.32) \quad z_1 = a_{21}, \quad z_2 = a_{22},$$

and if we define

$$(3.33) \quad \tilde{\varphi}(z_1, z_2) = \hat{\varphi}(a),$$

we have

$$(3.34) \quad \tilde{\varphi}(\alpha z_1, \alpha z_2) = \alpha^{-2} \tilde{\varphi}(z_1, z_2) \quad (\operatorname{Im} \alpha = 0).$$

Clearly the transformation property is

$$(3.35) \quad [U(a)\tilde{\varphi}](z_1, z_2) = \tilde{\varphi}(z'_1, z'_2),$$

where  $z'_1$  and  $z'_2$  are given by equation (3.9).

If we introduce the functions

$$(3.36) \quad \left\{ \begin{array}{l} \tilde{\Phi}^M(z_1, z_2) = (2\pi)^{-1} \int_0^{2\pi} \tilde{\varphi}(e^{i\psi} z_1, e^{i\psi} z_2) e^{2iM\psi} d\psi, \\ (M = 0, \pm 1, \pm 2, \dots) \end{array} \right.$$

they satisfy the covariance property

$$(3.37) \quad \tilde{\Phi}^M(\alpha z_1, \alpha z_2) = \alpha^{-1-M} \bar{\alpha}^{-1+M} \tilde{\Phi}^M(z_1, z_2),$$

and therefore they transform according to the representation  $\mathcal{O}^{M,0}$ .

Also in this case we introduce the functions defined on  $SU(2)$  :

$$(3.38) \quad \begin{aligned} \Phi^M(u) &= \tilde{\Phi}^M(u_{21}, u_{22}) \\ &= (2\pi)^{-1} \int_0^{2\pi} \hat{\varphi}(u_x(2\psi)u) e^{2iM\psi} d\psi. \end{aligned}$$

Using equations (2.3) and (3.28) we obtain

$$(3.39) \quad \begin{aligned} \Phi^M(u) &= (2\pi)^{-1} \int_0^{2\pi} d\psi e^{2iM\psi} \\ &\quad \times \int_{-\infty}^{+\infty} f(L(u^{-1}u_x(-2\psi))(\tilde{b} + t\tilde{\xi})) dt. \end{aligned}$$

Also in this case the transformation properties of this function are just those given in ([27]-[29]). Projecting it on the basis (3.18) we get

$$(3.40) \quad \Phi_{jm}^M = (2j+1)^{1/2} \int_{SU(2)} \overline{R_{Mm}^j(u)} \Phi^M(u) d^3u.$$

We remark that we must have  $j \geq |M|$ .

It is useful to write

$$(3.41) \quad \begin{cases} \tilde{b} + t\tilde{\xi} = L(u_y(\beta))\tilde{x}, \\ \tilde{x} = (\text{sh } \alpha, 0, 0, \text{ch } \alpha); \end{cases} \quad \begin{cases} \text{sh } \alpha = t, \\ \text{tg } \beta = t^{-1}, \\ 0 < \beta < \pi. \end{cases}$$

Using Equations (3.29) we have

$$(3.42) \quad \begin{aligned} \Phi_{jm}^M &= (2j+1)^{1/2} \int_{-\infty}^{+\infty} dt \int_{SU(2)} \overline{R_{Mm}^j(u)} f(L(u^{-1}u_y(\beta))\tilde{x}) d^3u \\ &= (2j+1)^{1/2} \int_{-\infty}^{+\infty} d \text{sh } \alpha \int_{SU(2)} \overline{R_{Mm}^j(u_y(\beta)u)} f(L(u^{-1})\tilde{x}) d^3u. \end{aligned}$$

Introducing the polar variables (3.23) and using the representation property of the rotation matrices, we get after some calculation

$$(3.43) \quad \Phi_{jm}^M = \int f(x) \overline{C_{jm}^M(x)} d\Gamma,$$

where

$$(3.44) \quad C_{jm}^M(x) = Y_{jm}(\theta, \varphi) c_j^M(\alpha),$$

$$(3.45) \quad c_j^M(\alpha) = (4\pi)^{-1/2} R_{M0}^j(u_y(\beta)) (\text{ch } \alpha)^{-1},$$

that is

$$(3.46) \quad c_j^M(\alpha) = (4\pi)^{-1/2} \left( \frac{(j-M)!}{(j+M)!} \right)^{1/2} \mathbf{P}_j^M(\text{th } \alpha) (\text{ch } \alpha)^{-1}.$$



In conclusion we have

PROPOSITION 2. — *If the function  $f(x)$  belongs to  $\mathcal{O}(\Gamma)$ , we can define its Fourier transforms*

$$(3.47) \quad H_{jm}^\lambda = \int f(x) (-1)^m B_{j,-m}^{-\lambda}(x) d\Gamma,$$

$$(3.48) \quad \Phi_{jm}^M = \int f(x) \overline{C_{jm}^M(x)} d\Gamma.$$

*If the function  $f(x)$  undergoes the Lorentz transformation (3.1), these quantities transform as follows*

$$(3.49) \quad H_{jm}^\lambda \rightarrow \sum_{j'm'} \omega_{jmj'm'}^{0\lambda}(a) H_{j'm'}^\lambda,$$

$$(3.50) \quad \Phi_{jm}^M \rightarrow \sum_{j'm'} \omega_{jmj'm'}^{M0}(a) \Phi_{j'm'}^M,$$

where  $\omega_{jmj'm'}^{M\lambda}(a)$  are the matrix elements of the irreducible representations of  $SL(2, C)$  in the basis (3.18). Explicit expressions for these quantities are given for instance in [29]. The equations (3.47) and (3.49) hold for arbitrary complex  $\lambda$  with the exception of the non-positive integers. When  $\Re \lambda = 0$ , equation (3.47) can be written as

$$(3.51) \quad H_{jm}^\lambda = \int f(x) \overline{B_{jm}^\lambda(x)} d\Gamma.$$

#### 4. Properties of the functions $B_{jm}^\lambda(x)$ and $C_{jm}^M(x)$

In this Section we exhibit some properties of the functions defined by equations (3.25), (3.27), (3.44) and (3.46). From equations (3.27) and (3.46), using the formulae (3.4.14) and (3.4.17) of HTF [31], we get

$$(4.1) \quad b_j^{-\lambda}(-\alpha) = \frac{\Gamma(\lambda) \Gamma(1 - \lambda + j)}{\Gamma(-\lambda) \Gamma(1 + \lambda + j)} (-1)^j b_j^\lambda(\alpha),$$

$$(4.2) \quad c_j^M(-\alpha) = (-1)^{M+j} c_j^M(\alpha),$$

$$(4.3) \quad c_j^{-M}(\alpha) = (-1)^M c_j^M(\alpha).$$

Using the formulae (3.9.8) and (3.9.9) of HTF, we get the asymptotic behaviours

$$(4.4) \quad b_j^\lambda(x) \underset{\alpha \rightarrow +\infty}{\simeq} -\lambda^{-1} \pi^{-1/2} \exp[\alpha(\lambda - 1)],$$

$$(4.5) \quad \left\{ \begin{array}{l} c_j^M(\alpha) \underset{\alpha \rightarrow +\infty}{\simeq} (-1)^M \pi^{-1/2} (M!)^{-1} \left( \frac{(j+M)!}{(j-M)!} \right)^{1/2} \exp[-\alpha(M+1)] \\ (M = 0, 1, 2, \dots). \end{array} \right.$$

The function  $b_j^\lambda(\alpha)$  is analytic in the whole  $\lambda$  plane apart from poles at the integral points  $\lambda = 0, 1, 2, \dots, j$ . We call them the "Lorentz nonsense points". The residues are

$$(4.6) \quad \operatorname{res}_{\lambda=M} b_j^\lambda(\alpha) = (-1)^{M+1} (M!)^{-1} \left( \frac{(j+M)!}{(j-M)!} \right)^{1/2} c_j^M(\alpha) \quad (j \geq M \geq 0).$$

Besides we have the identity

$$(4.7) \quad b_j^{-M}(\alpha) = (-1)^M (M-1)! \left( \frac{(j-M)!}{(j+M)!} \right)^{1/2} c_j^M(\alpha) \quad (j \geq M > 0).$$

Comparing these identities with the definitions (3.47) and (3.48), we see that

PROPOSITION 3. — *If  $f(x) \in \mathcal{O}(\Gamma)$ , the function  $H_{j,m}^\lambda$  is analytic in the whole complex  $\lambda$  plane apart from simple poles at the points  $\lambda = 0, -1, -2, \dots, -j$  with residues given by*

$$(4.8) \quad \operatorname{res}_{\lambda=-M} H_{j,m}^\lambda = (-1)^M (M!)^{-1} \left( \frac{(j+M)!}{(j-M)!} \right)^{1/2} \Phi_{j,m}^M \quad (M = 0, 1, \dots, j).$$

Moreover, we have the identities

$$(4.9) \quad H_{j,m}^M = (-1)^M (M-1)! \left( \frac{(j-M)!}{(j+M)!} \right)^{1/2} \Phi_{j,m}^M \quad (M = 1, 2, \dots, j),$$

$$(4.10) \quad \Phi_{j,m}^{-M} = (-1)^M \Phi_{j,m}^M.$$

We shall also use the majorizations

$$(4.11) \quad |\lambda b_j^\lambda(\alpha)| \leq (4\pi)^{-1/2} (\operatorname{ch} \alpha)^{-1} (j^2 + j + 1) \exp(\alpha \operatorname{Re} \lambda) \quad (\operatorname{Re} \lambda \leq 0),$$

$$(4.12) \quad |\lambda b_j^\lambda(\alpha)| \leq (4\pi)^{-1/2} (\operatorname{ch} \alpha)^{-1} (j^2 + j + 1) \times \left| \frac{\Gamma(-\lambda) \Gamma(1 + \lambda + j)}{\Gamma(\lambda) \Gamma(1 - \lambda + j)} \right| \exp(\alpha \operatorname{Re} \lambda) \quad (\operatorname{Re} \lambda \geq 0),$$

$$(4.13) \quad \left\{ \begin{array}{l} |c_j^M(\alpha)| \leq (4\pi)^{-1/2} (\operatorname{ch} \alpha)^{-1} \\ \times \left[ \frac{1}{|M|!} \left( \frac{(j+|M|)!}{(j-|M|)!} \right)^{1/2} \right]^{\hat{M}} \exp(-|\hat{M}\alpha|) \\ \leq (4\pi)^{-1/2} (\operatorname{ch} \alpha)^{-1} \left( \frac{e}{|M|} \left( j + \frac{1}{2} \right) \right)^{\hat{M}} \exp(-|\hat{M}\alpha|), \\ (0 \leq \hat{M} \leq |M|). \end{array} \right.$$

Equation (4.11) can be obtained from the integral representation (3.26) after an integration by parts. Equation (4.12) follows using equation (4.1). Equation (4.13) is a consequence of the definition (3.46) and of equation (3.7.30) of HTF [31].

Now we want to study the behaviour of our functions under infinitesimal Lorentz transformations. We introduce the differential operators (generators) :

$$(4.14) \quad \mathbf{M}_z f(x) = \left[ \frac{\partial}{\partial \mu} f(\mathbf{L}(u_z(-\mu))x) \right]_{\mu=0} = \left[ x_2 \frac{\partial}{\partial x_1} - x_1 \frac{\partial}{\partial x_2} \right] f(x),$$

$$(4.15) \quad \mathbf{L}_z f(x) = \left[ \frac{\partial}{\partial \zeta} f(\mathbf{L}(a_z(-\zeta))x) \right]_{\zeta=0} = \left[ -x_3 \frac{\partial}{\partial x_0} - x_0 \frac{\partial}{\partial x_3} \right] f(x),$$

where  $a_z(\zeta)$  means a boost along the  $z$  axis with rapidity  $\zeta$ . The other four generators can be obtained by rotation of the indices. In the last expressions in equations (4.14) and (4.15) we have to consider an arbitrary  $C^\infty$  extension of  $f(x)$  outside the hyperboloid.

The action of the infinitesimal rotations can be obtained from well-known properties of the spherical harmonics [30] and is

$$(4.16) \quad \begin{cases} (\mathbf{M}_x \pm i \mathbf{M}_y) B_{jm}^\lambda(x) = -i[(j \mp m)(j \pm m + 1)]^{1/2} B_{j, m \pm 1}^\lambda(x), \\ \mathbf{M}_z B_{jm}^\lambda(x) = -im B_{jm}^\lambda(x); \end{cases}$$

$$(4.17) \quad (\mathbf{M}_x^2 + \mathbf{M}_y^2 + \mathbf{M}_z^2) B_{jm}^\lambda(x) = -j(j+1) B_{jm}^\lambda(x).$$

Exactly similar formulae hold for  $C_{jm}^M(x)$ .

The action of  $\mathbf{L}_z$  can be found by direct calculation using the formulae (3.8.19) and (3.8.12) of HTF and we get

$$(4.18) \quad \mathbf{L}_z B_{jm}^\lambda(x) = (j - \lambda + 1) \left[ \frac{(j+1+m)(j+1-m)}{(2j+1)(2j+3)} \right]^{1/2} B_{j+1, m}^\lambda(x) \\ - (j + \lambda) \left[ \frac{(j+m)(j-m)}{(2j+1)(2j-1)} \right]^{1/2} B_{j-1, m}^\lambda(x);$$

$$(4.19) \quad \mathbf{L}_z C_{jm}^M(x) \\ = \left[ \frac{(j+1+M)(j+1-M)(j+1+m)(j+1-m)}{(2j+1)(2j+3)} \right]^{1/2} C_{j+1, m}^M(x) \\ - \left[ \frac{(j+M)(j-M)(j+m)(j-m)}{(2j+1)(2j-1)} \right]^{1/2} C_{j-1, m}^M(x).$$

The generators  $\mathbf{L}_x$  and  $\mathbf{L}_y$  can be obtained from the commutation relations

$$(4.20) \quad \mathbf{L}_x = \mathbf{M}_y \mathbf{L}_z - \mathbf{L}_z \mathbf{M}_y, \quad \mathbf{L}_y = \mathbf{L}_z \mathbf{M}_x - \mathbf{M}_x \mathbf{L}_z.$$

By repeated use of these relations one gets

$$(4.21) \quad (\mathbf{L}_x^2 + \mathbf{L}_y^2 + \mathbf{L}_z^2 - \mathbf{M}_x^2 - \mathbf{M}_y^2 - \mathbf{M}_z^2) B_{jm}^\lambda(x) = (\lambda^2 - 1) B_{jm}^\lambda(x),$$

$$(4.22) \quad (\mathbf{L}_x^2 + \mathbf{L}_y^2 + \mathbf{L}_z^2 - \mathbf{M}_x^2 - \mathbf{M}_y^2 - \mathbf{M}_z^2) C_{jm}^M(x) = (M^2 - 1) C_{jm}^M(x).$$

Now we consider the equations (3.47) and (3.48) and we apply several times to their integrand the equations (4.17), (4.21) and (4.22). As  $f(x)$  is  $C^\infty$  and has compact support we can integrate by parts and using the bounds (4.11)-(4.13) we get the following result

PROPOSITION 4. — *If  $f(x)$  is  $C^\infty$  and has compact support, the quantities defined in equations (3.47) and (3.48) satisfy the bounds*

$$(4.23) \quad |\lambda H_{jm}^\lambda| \leq (1 + |\mathfrak{J}m \lambda|)^{-p} (1 + j)^{-q} k(p, q, \mathfrak{Re} \lambda) \quad (\mathfrak{Re} \lambda \geq 0),$$

$$(4.24) \quad |\lambda H_{jm}^\lambda| \leq \left| \frac{\Gamma(\lambda) \Gamma(1 - \lambda + j)}{\Gamma(-\lambda) \Gamma(1 + \lambda + j)} \right| (1 + |\mathfrak{J}m \lambda|)^{-p} \\ \times (1 + j)^{-q} k(p, q, \mathfrak{Re} \lambda) \quad (\mathfrak{Re} \lambda \leq 0),$$

$$(4.25) \quad |\Phi_{jm}^M| \leq (j + 1)^{-q} k(q),$$

where  $p$  and  $q$  are arbitrary integers and the function  $k(p, q, \mathfrak{Re} \lambda)$  is continuous in  $\mathfrak{Re} \lambda$ . Of course the functions  $k$  depend on  $f(x)$ .

Another useful result can be obtained by remarking that a generator applied to a function  $B_{jm}^\lambda(x)$  [respectively  $C_{jm}^M(x)$ ] gives rise to a finite sum of functions of the same kind with different values of  $j$  and  $m$  multiplied by coefficients which can be majorized by a polynomial in  $j$  and  $|\lambda|$  (respectively by a polynomial in  $j$ ). From this remark, from the bounds (4.11), (4.13) and from equation (4.1), we get

PROPOSITION 5. — *If  $P$  is a polynomial in the generators, we have*

$$(4.26) \quad |\lambda PB_{jm}^\lambda(x)| \leq (\text{ch } \alpha)^{-1} \exp(\alpha \mathfrak{Re} \lambda) Q(j, |\lambda|) \quad (\mathfrak{Re} \lambda \leq 0),$$

$$(4.27) \quad |\lambda PB_{jm}^\lambda(x)| \leq \left| \frac{\Gamma(-\lambda) \Gamma(1 + \lambda + j)}{\Gamma(\lambda) \Gamma(1 - \lambda + j)} \right| (\text{ch } \alpha)^{-1} \\ \times \exp(\alpha \mathfrak{Re} \lambda) Q(j, |\lambda|), \quad (\mathfrak{Re} \lambda \geq 0),$$

$$(4.28) \quad |PC_{jm}^M(x)| \leq (\text{ch } \alpha)^{-1} \exp(-\hat{M}|\alpha|) Q(j) \quad (0 \leq \hat{M} \leq |M|),$$

where  $Q(j, |\lambda|)$  and  $Q(j)$  are polynomials which depend only on the polynomial  $P$  and in the last case on  $\hat{M}$ .

## 5. The inverse formula

In order to reconstruct the function  $f(x)$  starting from its Fourier transforms (3.47), (3.48), we start from the inverse Radon transform (2.26). The first term of this formula can be written in the form

$$(5.1) \quad - (2\pi)^{-1} \int_{\text{SU}(2)} d^3 u \int_0^\infty \xi_0 d\xi_0 \\ \times [\partial''((x', L(u^{-1})\tilde{\xi})\xi_0 + 1) + \partial'((x', L(u^{-1})\tilde{\xi})\xi_0 + 1)] \\ \times h(\xi_0 L(u^{-1})\tilde{\xi}),$$

where  $\tilde{\xi}$  is defined in equation (3.16). Inverting the Mellin transform (3.15) we get

$$(5.2) \quad h(\xi_0 L(u^{-1}) \tilde{\xi}) = -2i \int_{\varepsilon-i\infty}^{\varepsilon+i\infty} \xi_0^{\lambda-1} H^\lambda(u) d\lambda \quad (\varepsilon > 0),$$

and substituting into equation (5.1) we get

$$(5.3) \quad i \pi^{-1} \int_{-i\infty}^{+i\infty} \lambda^2 d\lambda \int_{\text{SU}(2)} d^3 u [- (x', L(u^{-1}) \tilde{\xi})]_+^{-\lambda-1} H^\lambda(u).$$

In order to treat the second term of equation (2.26), we consider the equation

$$(5.4) \quad \varphi(L(u^{-1}) \tilde{b}, L(u^{-1}) \tilde{\xi}) = \sum_{M=-\infty}^{+\infty} \Phi^M(u),$$

which follows from equations (3.28) and (3.38).

If we parametrize the rotation  $u$  as

$$(5.5) \quad u = u_z(-\nu) u_y(-\eta) u_z(-\mu),$$

the angles  $\eta$  and  $\mu$  are just polar co-ordinates for the vector  $\tilde{\xi}$ . The angle  $\nu$  is determined by the condition (2.27) which takes the form

$$(5.6) \quad (L(u^{-1}) \tilde{b}, x') = -\cos \theta.$$

If we put

$$(5.7) \quad \hat{x} = L(u_y(-\eta) u_z(-\mu)) x',$$

equation (5.6) takes the form

$$(5.8) \quad \hat{x}_1 \cos \nu + \hat{x}_2 \sin \nu = \cos \theta.$$

Due to the  $\delta$  function which appears in the second integral of equation (2.26), we must require

$$(5.9) \quad (x', \xi) = (\hat{x}, \tilde{\xi}) = \hat{x}_0 - \hat{x}_3 = 0$$

and therefore

$$(5.10) \quad \hat{x}_1^2 + \hat{x}_2^2 = 1.$$

As a consequence, equation (5.8) takes the general form

$$(5.11) \quad \nu = \theta + \tilde{\nu}$$

and we can write

$$5.12) \quad u = u_z(-\theta) \tilde{u},$$

$$(5.13) \quad \tilde{u} = u_z(-\tilde{\nu}) u_y(-\eta) u_z(-\mu).$$

Remark that  $\tilde{u}$  depends only on the parameters  $\eta$  and  $\mu$ , as  $\tilde{v}$  is determined by the condition

$$(5.14) \quad (\mathbf{L}(\tilde{u}^{-1}) \tilde{b}, x') = -1.$$

Using equation (5.4) and the covariance condition

$$(5.15) \quad \Phi^{\mathbf{M}}(u_{\varepsilon}(-\theta) \tilde{u}) = \exp(i \mathbf{M} \theta) \Phi^{\mathbf{M}}(\tilde{u}),$$

which follows from the definition (3.38), we can write the second term in equation (2.26) in the form

$$(5.16) \quad (4 \pi)^{-1} \sum_{\mathbf{M}} \gamma_{\mathbf{M}} \int_{-1}^{+1} d \cos \eta \int_0^{2 \pi} d \mu \delta((x', \mathbf{L}(\tilde{u}^{-1}) \tilde{\xi})) \Phi^{\mathbf{M}}(\tilde{u}),$$

where

$$(5.17) \quad \gamma_{\mathbf{M}} = -\pi^{-1} \int_0^{\pi} \exp(i \mathbf{M} \theta) (1 - \cos \theta)^{-1} d \theta.$$

In order to compute this integral, which is singular, we have to remember how equation (2.19) was derived starting from equation (2.11). We see in this way that it has to be interpreted as the analytic continuation in  $\mu = -3$  of the integral

$$(5.18) \quad (2 \pi)^{-1} \int_0^{2 \pi} \left[ (1 - e^{-i \theta})^{\mu+1} + (1 - e^{i \theta})^{\mu+1} + \frac{1}{2}(\mu + 1) (1 - e^{-i \theta})^{\mu+2} + \frac{1}{2}(\mu + 1) (1 - e^{i \theta})^{\mu+2} \right] e^{i \mathbf{M} \theta} d \theta.$$

After some calculation we get

$$(5.19) \quad \gamma_{\mathbf{M}} = |\mathbf{M}|.$$

In conclusion, we have

PROPOSITION 6. — *If  $f \in \mathcal{O}(\Gamma)$ , the Fourier transforms (3.17) and (3.39) can be inverted by means of the formula*

$$(5.20) \quad f(x') = i \pi^{-1} \int_{-i \infty}^{+i \infty} \lambda^2 d \lambda \int_{\text{SU}(2)} d^3 u [-\langle x', \mathbf{L}(u^{-1}) \tilde{\xi} \rangle]_{+}^{-\lambda-1} \mathbf{H}^{\lambda}(u) + \sum_{\mathbf{M}=-\infty}^{+\infty} |\mathbf{M}| \int_{\text{SU}(2)} d^3 u \delta(\langle x', \mathbf{L}(u^{-1}) \tilde{\xi} \rangle) \Phi^{\mathbf{M}}(\tilde{u}),$$

where the rotation  $\tilde{u}$  is defined in terms of the rotation  $u$  by means of equations (5.12) and (5.14).

If we introduce the basis (3.18), from equations (3.19) and (3.40) we get

$$(5.21) \quad H^\lambda(u) = \sum_{jm} \sqrt{2j+1} R_{0m}^j(u) H_{jm}^\lambda$$

$$(5.22) \quad \Phi^M(u) = \sum_{im} \sqrt{2j+1} R_{Mm}^j(u) \Phi_{jm}^M$$

Using equation (5.21) and the definition (3.21), the first integral in equation (5.20) takes the form

$$(5.23) \quad 2i \int_{-i\infty}^{+i\infty} \lambda^2 d\lambda \sum_{jm} B_{jm}^\lambda(x') H_{jm}^\lambda$$

In order to treat the second term in equation (5.20), we introduce the polar co-ordinates

$$(5.24) \quad x' = L(u_z(\varphi') u_y(\theta')) \tilde{x}'$$

$$(5.25) \quad \tilde{x}' = (\text{sh } \alpha', 0, 0, \text{ch } \alpha'),$$

and the new rotations

$$(5.26) \quad v = u_z(\sigma) u_y(\chi) u_z(\tau) = u u_z(\varphi') u_y(\theta')$$

$$(5.27) \quad \tilde{v} = u_z(\tilde{\sigma}) u_y(\chi) u_z(\tau) = \tilde{u} u_z(\varphi') u_y(\theta')$$

Then the second integral in equation (5.20) takes the form

$$(5.28) \quad \sum_{\mathbf{M}} |\mathbf{M}| \sum_{jm} (2j+1)^{1/2} \int_{\text{SU}(2)} d^3v \delta(\text{sh } \alpha' - \text{ch } \alpha' \cos \chi) \\ \times \sum_{m'} R_{Mm'}^j(\tilde{v}) R_{m'm}^j(u_y(-\theta') u_z(-\varphi')) \Phi_{jm}^M$$

and the condition (5.14) becomes

$$(5.29) \quad \text{ch } \alpha' \sin \chi \cos \tilde{\sigma} = 1.$$

We can perform the integral (5.28) using the  $\delta$  function. We have, also from equation (5.29),

$$(5.30) \quad \text{th } \alpha' = \cos \chi, \quad \cos \tilde{\sigma} = 1,$$

and equation (5.28) takes the form

$$(5.31) \quad \pi^{1/2} \sum_{\mathbf{M}} |\mathbf{M}| \sum_{jm} (\text{ch } \alpha')^{-1} R_{M0}^j(u_y(\chi)) Y_{jm}(\theta', \varphi') \Phi_{jm}^M \\ = 2\pi \sum_{\mathbf{M}} |\mathbf{M}| \sum_{jm} C_{jm}^M(x') \Phi_{jm}^M$$

Using the symmetry properties (4.3) and (4.10), we can restrict the sum over  $M$  to positive values and we get the final result

PROPOSITION 7. — *If  $f \in \mathcal{O}(\Gamma)$ , the Fourier transforms (3.47) and (3.48) can be inverted by means of the formula*

$$(5.32) \quad f(x') = 2i \int_{-i\infty}^{+i\infty} \lambda^2 d\lambda \sum_{jm} B_{jm}^\lambda(x') H_{jm}^\lambda + 4\pi \sum_{M=1}^{\infty} M \sum_{jm} C_{jm}^M(x') \Phi_{jm}^M.$$

Here and throughout this paper the sums over  $j$  and  $m$  are always extended to all the integral values of these indices such that  $j \geq |M|$  and  $|m| \leq j$ .

If we multiply equation (5.32) by a function  $f_c(x')$  belonging to  $\mathcal{O}(\Gamma)$  and we use equations (3.47) and (3.48), we get the Plancherel formula

$$(5.33) \quad \int f_c(x) f(x) d\Gamma = 2i \int_{-i\infty}^{+i\infty} \lambda^2 d\lambda \sum_{jm} (-1)^m H_{Cjm}^\lambda H_{j,-m}^{-\lambda} + 4\pi \sum_{M=1}^{\infty} M \sum_{im} (-1)^m \Phi_{Cjm}^M \Phi_{j,-m}^M.$$

### 6. The Laplace transform on the hyperboloid

In the preceding sections we have studied the Fourier transformation of functions on the hyperboloid belonging to the space  $\mathcal{O}(\Gamma)$ . We have seen that only pure imaginary values of  $\lambda$ , corresponding to unitary representations, are involved in the inverse and in the Plancherel formulae. These results can be generalized to arbitrary  $L^2$  functions on the hyperboloid. However, in order to expand functions of a more general kind, we have to consider values of  $\lambda$  which are not purely imaginary. The situation is very similar to the one we find in the two-sided Laplace transform of a function defined on the real line.

We start from equation (5.33), in which  $f$  and  $f_c$  belong to  $\mathcal{O}(\Gamma)$ . Using the bounds (4.23) and (4.24), we see that it is possible to shift the integration path on the line  $\text{Re } \lambda = L$ , where  $L$  is an arbitrary real non integral number. In doing this, we cross some poles and, using equations (4.8) and (4.9), we see that their contribution cancels exactly some terms of the series in equation (5.33). We get in this way

$$(6.1) \quad \int f_c(x) f(x) d\Gamma = 2i \int_{L-i\infty}^{L+i\infty} \lambda^2 d\lambda \sum_{jm} (-1)^m H_{Cjm}^\lambda H_{j,-m}^{-\lambda} + \sum_{M > |L|} 4\pi M \sum_{jm} (-1)^m \Phi_{Cjm}^M \Phi_{j,-m}^M.$$



Now we want to extend this formula to the case in which  $f_c$  is a distribution with suitable properties. It is convenient to define a space  $\mathcal{S}(\Gamma)$  of test functions which are infinitely differentiable and have the following fast decrease property: for any polynomial  $P$  in the generators  $\mathbf{M}_x, \dots, \mathbf{L}_x$  with constant coefficients and for any integer  $q$  we have

$$(6.2) \quad \sup [\text{ch } \alpha (1 + |\alpha|)^q | P f(x) |] < \infty \quad (\text{sh } \alpha = x_0).$$

The semi-norms (6.2) define, as usual, the topology of  $\mathcal{S}(\Gamma)$ . This is a natural generalization of the space  $\mathcal{S}(\mathbb{R}^n)$  of test functions in  $\mathbb{R}^n$ . Also in this case we can introduce a corresponding space  $\mathcal{S}'(\Gamma)$  of "tempered" distributions [18].

We consider first a distribution  $f_c(x)$  with support in the part of the hyperboloid defined by  $\alpha > \alpha_1$  and such that

$$(6.3) \quad e^{-L_1 \alpha} f_c(x) \in \mathcal{S}'(\Gamma).$$

This means that the distribution  $f_c$  can be applied to the  $C^\infty$  function  $f(x)$  if

$$(6.4) \quad \theta_\varepsilon(\alpha - \alpha_1) e^{L_1 \alpha} f(x) \in \mathcal{S}(\Gamma),$$

where  $\theta_\varepsilon(t)$  is a regularized step function equal to one for  $t \geq 0$  and to zero for  $t \leq -\varepsilon$ .

Using the Lemma of Appendix A, and the bounds (4.26)-(4.28), we see that the functions  $B_{j_m}^{-\lambda}(x)$  satisfy the condition (6.4) for

$$(6.5) \quad L_1 < \alpha e \lambda \quad (\lambda \neq 0, -1, -2, \dots, -j),$$

while the functions  $C_{j_m}^M(x)$  have this property for

$$(6.6) \quad L_1 < |M|.$$

If the conditions (6.5) and (6.6) are satisfied, the integrals (3.47) and (3.48), in which the distribution  $f_c$  takes the place of the function  $f$ , have a meaning in the sense of distributions. Moreover, due to the continuity property of distributions, the integral (3.47) is majorized by a finite sum of semi-norms of the kind

$$(6.7) \quad \sup [\text{ch } \alpha (1 + |\alpha|)^q | P \theta_\varepsilon(\alpha - \alpha_1) e^{L_1 \alpha} B_{j, -m}^{-\lambda}(x) |],$$

while the integral (3.48) is majorized by a finite sum of semi-norms of the kind

$$(6.8) \quad \sup [\text{ch } \alpha (1 + |\alpha|)^q | P \theta_\varepsilon(\alpha - \alpha_1) e^{L_1 \alpha} C_{j_m}^M(x) |].$$

Then, using the Lemma of Appendix A and the inequalities (4.26)-(4.28), we get the bounds

$$(6.9) \quad \begin{cases} |H_{cjm}^\lambda| \leq k(1+j)^p(1+|\mathcal{J}m\lambda|)^q, \\ |\alpha e^\lambda = L > L_1 \quad (L \neq 0, -1, \dots, -j), \end{cases}$$

$$(6.10) \quad |\Phi_{cjm}^M| \leq k'(j+1)^{p'} \quad (|M| > L_1),$$

where  $k, p$  and  $q$  depend on  $L$ , but not on  $j, m$  and  $\mathcal{J}m\lambda$ , while  $k'$  and  $p'$  do not depend on  $M, j$  and  $m$ .

Now we can show that equation (6.1) can be extended to the case in which  $f \in \mathcal{O}(\Gamma)$  and  $f_c$  is a distribution of the kind we are considering. First of all, we remark that the bounds (6.9), (6.10) and (4.23)-(4.25) ensure the convergence of the sums and the integrals which appear in the right-hand side of equation (6.1). Then we consider a sequence  $\{f_{c_i}\}$  of functions belonging to  $\mathcal{O}(\Gamma)$  such that

$$(6.11) \quad e^{-L\alpha} f_{c_i}(x) \xrightarrow{i \rightarrow \infty} e^{-L\alpha} f_c(x)$$

in the topology of  $\mathcal{S}'(\Gamma)$ . From a general property of distribution spaces [18] we have that the distributions which appear in equation (6.11) are equicontinuous functionals in  $\mathcal{S}(\Gamma)$ . It follows that the Laplace transforms of the functions  $f_{c_i}$  satisfy bounds similar to equations (6.9) and (6.10) with the right-hand side independent of  $i$ . We write equation (6.1) for the functions  $f$  and  $f_{c_i}$  and the result we need is obtained by performing the limit  $i \rightarrow \infty$ . This procedure is justified by the bounds derived above.

A similar treatment can be given for distributions which have support in the part of the hyperboloid defined by

$$(6.12) \quad \alpha < \alpha_2$$

and such that

$$(6.13) \quad e^{-L_1\alpha} f_c(x) \in \mathcal{S}'(\Gamma).$$

Then equation (6.1) holds for  $L < L_2$ .

In conclusion we see that equation (6.1) holds whenever the distribution  $f_c$  satisfies both the conditions (6.3) and (6.13), provided that

$$(6.14) \quad L_1 < L < L_2 \quad (L \neq \pm 1, \pm 2, \dots).$$

In fact in this case the distribution  $f_c$  can be decomposed into the sum of two distributions of the kind considered above.

Now we want to get a further extension of equation (6.1) in the case in which

$$(6.15) \quad f(x) e^{L\alpha} \in \mathcal{S}(\Gamma).$$

It is easy to show that under this conditions  $H_{jm}^\lambda$  is defined for  $\Re \lambda = -L$  and  $\Phi_{jm}^M$  is defined for  $M \geq |L|$ . Moreover, these functions satisfy inequalities similar to equations (4.23)-(4.25). These inequalities ensure the existence of the right-hand side of equation (6.1), which can again be extended by means of the procedure used above.

In conclusion we have

PROPOSITION 8. — *If the distribution  $f_c(x)$  satisfies the conditions*

$$(6.16) \quad \begin{cases} e^{-L_1 x} f_c(x) \in \mathcal{S}'(\Gamma), \\ e^{-L_2 x} f_c(x) \in \mathcal{S}'(\Gamma) \end{cases} \quad (L_1 < L_2),$$

*its Laplace transforms, given by formulae similar to equations (3.47) and (3.48), are defined for*

$$(6.17) \quad L_1 < \Re \lambda < L_2, \quad M > \max [L_1, -L_2],$$

*and under these conditions satisfy the bounds (6.9) and (6.10). If the function  $f(x)$  satisfies the condition (6.15), its Laplace transforms are defined for*

$$(6.18) \quad \Re \lambda = -L, \quad M \geq |L|$$

*and satisfy the bounds (4.23)-(4.25).*

*Under these conditions, and if equation (6.14) is satisfied, the formula (6.1) holds.*

## 7. Invariant kernels

By invariant kernel we mean a function or a distribution  $K(x, x')$  with the property

$$(7.1) \quad K(L(a)x, L(a)x') = K(x, x'),$$

where  $x$  and  $x'$  are points of the hyperboloid and  $a$  is an element of  $SL(2, C)$ .

The action of a kernel on a function  $f(x)$  can be written formally as

$$(7.2) \quad [Kf](x) = \int K(x, x') f(x') d\Gamma'.$$

This definition is meaningful only if the kernel and the function satisfy some conditions. We are interested in studying some class of kernels which transform some well-defined function space into itself.

We consider first kernels which are continuous functions and we impose that the integral (7.2) is absolutely convergent. Then if  $K$  transforms

a function space into itself, the iterated kernel

$$(7.3) \quad K_2(x, x'') = \int K(x, x') K(x', x'') d\Gamma'.$$

must exist.

It is easy to show that  $K$  can depend only on the quantities

$$(7.4) \quad z = -(x, x'), \quad \varepsilon_{\pm} = \text{sign}(x_0 \pm x'_0),$$

and that it can depend on  $\varepsilon_-$  only when  $z \geq 1$  and on  $\varepsilon_+$  only when  $z \leq -1$ .

One can easily realize that if the kernel  $K$  depends only on  $z$  but not on  $\varepsilon_{\pm}$ , the integral in equation (7.3) cannot be absolutely convergent. This is the origin of the difficulties one finds in the group-theoretical treatment of the Bethe-Salpeter equation at vanishing four-momentum. Therefore, we restrict our investigation to kernels of the form

$$(7.5) \quad K(x, x') = \theta(x_0 - x'_0) \hat{k}(z),$$

where

$$(7.6) \quad \hat{k}(z) = 0 \quad \text{for } z \leq 1,$$

which are just of the kind which appears in the multiperipheral models. Three other classes of kernels can be obtained just changing the sign of  $x$  or  $x'$  and can be treated in a similar way.

We consider the space  $\omega_+(\Gamma)$  of the infinitely differentiable functions on  $\Gamma$  which vanish for  $x_0$  smaller than some constant (which depends on the function). One can develop a mathematical treatment of this space in close analogy with the treatment given in [18] of the space  $\omega_+$  of the  $C^\infty$  functions of the real line which vanish for sufficiently small values of their argument. In particular, one can introduce a suitable topology on  $\omega_+(\Gamma)$  and show that the dual of  $\omega_+(\Gamma)$  is the space  $\omega'_-(\Gamma)$  of the distributions vanishing for sufficiently large  $x_0$ . In a similar way we introduce the space  $\omega_-(\Gamma)$  of the  $C^\infty$  functions vanishing for sufficiently large  $x_0$  and the corresponding dual space  $\omega'_+(\Gamma)$  of the distributions vanishing for sufficiently small  $x_0$ .

Now we assume that

$$(7.7) \quad \hat{k}(z) = (\text{sh } \beta)^{-1} k(\beta) \quad (z = \text{ch } \beta),$$

where  $k(\beta)$  is a distribution with support in the half line  $\beta \geq \beta_0 > 0$ . Under this condition, it is easy to show by means of suitable changes of variables, that  $K(x, x')$  is a distribution in the two variables  $x, x'$ . Moreover, for fixed  $x'$  it is a distribution in  $x$  belonging to  $\omega'_+(\Gamma)$  and for fixed  $x$  it is a distribution in  $x'$  belonging to  $\omega'_-(\Gamma)$ .

To be more specific, if  $f \in \omega_-(\Gamma)$  and we put

$$(7.8) \quad \psi(x', \beta) = \int f(x) \delta((x, x') + \text{ch } \beta) \theta(x_0 - x'_0) d\Gamma,$$

we have

$$(7.9) \quad [K^T f](x') = \int K(x, x') f(x) d\Gamma = \int k(\beta) \psi(x', \beta) d\beta.$$

It is easy to show that the function  $[K^T f](x')$  defined in equation (7.9) belongs to  $\omega_-(\Gamma)$ . In a similar way one can show that if  $f \in \omega_+(\Gamma)$ , the function  $[K f](x)$  defined in equation (7.2) belongs to  $\omega_+(\Gamma)$ . In this way we have defined two linear mappings  $K^T$  and  $K$ , respectively in  $\omega_-(\Gamma)$  and in  $\omega_+(\Gamma)$ , which can be shown to be continuous.

If  $f \in \omega_-(\Gamma)$  and  $f_c \in \omega_+(\Gamma)$ , we have

$$(7.10) \quad \int f(x) [K f_c](x) d\Gamma = \int [K^T f](x') f_c(x') d\Gamma'.$$

We remark that the right-hand side of this equation is meaningful also when  $f_c \in \omega'_+(\Gamma)$ . Therefore equation (7.10) can be used to define  $[K f_c](x)$  as a distribution of  $\omega'_+(\Gamma)$ .

In conclusion, we have

PROPOSITION 9. — *A kernel of the form*

$$(7.11) \quad K(x, x') = \theta(x_0 - x'_0) k(\beta) (\text{sh } \beta)^{-1} \quad [\text{ch } \beta = -(x, x')],$$

where  $k(\beta)$  is a distribution with support in the open half line  $\beta > 0$ , transforms the spaces  $\omega_+(\Gamma)$  and  $\omega'_+(\Gamma)$  continuously into themselves. The transposed kernel  $K^T$  transforms the spaces  $\omega_-(\Gamma)$  and  $\omega'_-(\Gamma)$  continuously into themselves.

In order to introduce the Laplace transforms, we have to restrict the space of distributions on the hyperboloid imposing the condition (6.3) and to impose also some conditions on the kernel in such a way that it maps this more restricted space into itself.

First we consider equations (7.8) and (7.9) assuming that

$$(7.12) \quad f(x) = 0 \quad \text{for } x_0 \leq 0$$

and

$$(7.13) \quad e^{L_1 \alpha} f(x) \in \mathcal{S}(\Gamma) \quad (L_1 > 0, x_0 = \text{sh } \alpha).$$

Then from the majorization (B 11), we see that the function (7.8) has the property

$$(7.14) \quad \theta_\varepsilon(\beta - \beta_0) \psi(x', \beta) e^{L_1 \beta} \in \mathcal{S}(\mathbb{R}) \quad (\beta_0 > \varepsilon > 0).$$

Therefore the right-hand side of equation (7.9) is meaningful if the distribution  $k(\beta)$ , besides having its support in  $\beta \geq \beta_0$ , satisfies the condition

$$(7.15) \quad e^{-L_1 \beta} k(\beta) \in \mathcal{S}'(\mathbb{R}).$$

Moreover from equation (B 11) and the continuity property of the distribution (7.15), we get the inequality

$$(7.16) \quad |[K^T f](x')| \leq c'_\rho (\operatorname{ch} \alpha')^{-1} e^{-L_1 \alpha'} (1 + |\alpha'|)^{-\rho} \quad (\alpha' > 0),$$

where  $c'_\rho$  is a semi-norm continuous in  $\mathcal{S}(\Gamma)$  of the function (7.13).

From the Lorentz invariance of the kernel  $K$  we get

$$(7.17) \quad [PK^T f](x') = \int K(x, x') [P f](x) d\Gamma,$$

where  $P$  is an arbitrary polynomial (with constant coefficients) in the generators of the Lorentz transformations. It follows that  $[PK^T f](x')$  satisfies a bound similar to equation (7.16). In conclusion, we have shown that the function

$$(7.18) \quad \theta_\varepsilon(x'_0 + \varepsilon) e^{L_1 \alpha'} [K^T f](x')$$

belongs to  $\mathcal{S}(\Gamma)$  and depends continuously on the function (7.13).

Introducing this result in equation (7.10), we see that if the distribution  $f_c(x')$  has its support in  $x'_0 > \varepsilon$  and

$$(7.19) \quad e^{-L_1 \alpha'} f_c(x') \in \mathcal{S}'(\Gamma) \quad (L_1 > 0),$$

we have

$$(7.20) \quad e^{-L_1 \alpha} [K f_c](x) \in \mathcal{S}'(\Gamma).$$

In conclusion, Proposition 9 can be precised as follows

**PROPOSITION 10.** — *Under the conditions of Proposition 9, if  $k(\beta)$  satisfies the condition (7.15) with  $L_1 > 0$ , the kernel  $K$  transforms into itself the space of the distributions of  $\mathcal{O}'_+(\Gamma)$  which have the property (7.19).*

We remember that the functions  $B_{j_m}^{-\lambda}(x)$  and  $C_{j_m}^M(x)$  satisfy the condition (6.4) if the parameters  $\lambda$  and  $M$  satisfy the conditions (6.5) and (6.6). Then these functions can be decomposed into the sum of a function belonging to  $\mathcal{O}'_-(\Gamma)$  and a function satisfying the conditions (7.12) and (7.13). Therefore, if equation (7.15) is satisfied, we can apply to them the kernel  $K^T$ .

It is a simple calculation to show that, if we put in equations (7.8) and (7.9)  $f(x) = B_{0_0}^{-\lambda}(x)$ , we have

$$(7.21) \quad \begin{aligned} \psi(x', \beta) &= \int B_{0_0}^{-\lambda}(x) \delta((x, x') + \operatorname{ch} \beta) \theta(x_0 - x'_0) d\Gamma \\ &= 2 \pi \lambda^{-1} e^{-\lambda \beta} B_{0_0}^{-\lambda}(x') \quad (\operatorname{Re} \lambda > 0), \end{aligned}$$

and therefore

$$(7.22) \quad \int K(x, x') B_{00}^{-\lambda}(x) d\Gamma = \tilde{k}(\lambda) B_{00}^{-\lambda}(x'),$$

where

$$(7.23) \quad \tilde{k}(\lambda) = 2\pi\lambda^{-1} \int_0^{\infty} k(\beta) e^{-\lambda\beta} d\beta \quad (\Re \lambda > L_1 > 0).$$

Using equations (4.16), (4.18) and (7.17), we see that this equation is also valid for a general function of the kind  $B_{jm}^{-\lambda}(x)$ . From equation (4.7) we get

$$(7.24) \quad \int K(x, x') C_{jm}^M(x) d\Gamma = \tilde{k}(M) C_{jm}^M(x') \quad (M > L_1 > 0).$$

Introducing these results into equation (7.10), we get

PROPOSITION 11. — *If  $f_c$  is a distribution of  $\mathcal{O}_+(\Gamma)$  which satisfies the condition (7.19) and the kernel  $K$  is given by equation (7.11) where  $k(\beta)$  is a distribution with support in the open half line  $\beta > 0$  which satisfies the condition (7.15) with  $L_1 > 0$ , we have the following connection between the Laplace transforms of  $f_c$  and of  $K f_c$ :*

$$(7.25) \quad \int B_{j,-m}^{-\lambda}(x) [K f_c](x) d\Gamma = \tilde{k}(\lambda) \int B_{j,-m}^{-\lambda}(x) f_c(x) d\Gamma,$$

$$(7.26) \quad \int \overline{C_{jm}^M(x)} [K f_c](x) d\Gamma = \tilde{k}(M) \int \overline{C_{jm}^M(x)} f_c(x) d\Gamma,$$

where  $\tilde{k}(\lambda)$  is defined in equation (7.23).

## 8. Regularization of a distribution on $\Gamma$

Now we consider a function  $g(a)$  defined on the group  $SL(2, \mathbb{C})$ , infinitely differentiable and with compact support, that is an element of the test function space  $\mathcal{O}(SL(2, \mathbb{C}))$ . Its Laplace transform is given by

$$(8.1) \quad G_{jmj'm'}^{M\lambda} = \int_{SL(2, \mathbb{C})} \mathcal{O}_{jmj'm'}^{M\lambda}(a) g(a) d^6 a,$$

where  $d^6 a$  is the invariant measure. One can show that it satisfies inequalities of the kind

$$(8.2) \quad |G_{jmj'm'}^{M\lambda}| \leq C_{pq q'} (\Re \lambda) (1 + |\Im \lambda|)^{-p} (1 + j)^{-q} (1 + j')^{-q'},$$

where  $p, q, q'$  are arbitrary non-negative integers.

If  $f(x)$  belongs to  $\mathcal{O}(\Gamma)$ , we can consider the new function

$$(8.3) \quad f_D(x) = \int_{\text{SL}(2, \mathbb{C})} g(a) f(L(a^{-1})x) d^6 a,$$

which also belongs to  $\mathcal{O}(\Gamma)$ .

Using the results of Proposition 2, we see that the Laplace transforms of the function  $f_D$  are given by

$$(8.4) \quad H_{Djm}^\lambda = \sum_{j' m'} G_{jm j' m'}^{\lambda_0} H_{j' m'}^\lambda,$$

$$(8.5) \quad \Phi_{Djm}^M = \sum_{j' m'} G_{jm j' m'}^{M_0} \Phi_{j' m'}^M.$$

Equation (8.3) can be extended to the case in which  $f(x)$  is a distribution. We have in this case the following results which can be proved by means of standard procedures.

PROPOSITION 12. — *If in equation (8.3)  $f \in \mathcal{O}'(\Gamma)$ ,  $f_D(x)$  is an infinitely differentiable function, i. e., it belongs to  $\mathcal{E}(\Gamma)$ . In particular, the transformation (8.3) maps  $\mathcal{O}'_+(\Gamma)$  into  $\mathcal{O}_+(\Gamma)$ , and  $\mathcal{O}'_-(\Gamma)$  into  $\mathcal{O}_-(\Gamma)$ . If  $f(x)$  satisfies the conditions (6.16), the function  $f_D(x)$  satisfies the conditions*

$$(8.6) \quad e^{-L_1 x} f_D(x) \in \mathcal{S}(\Gamma), \quad \text{for } L_1 < L < L_2$$

and its Laplace transforms are given by equations (8.4) and (8.5).

### 9. The Laplace transform of inclusive distributions

In order to define the expression (1.13) as a distribution, we consider a test function  $g \in \mathcal{O}(\text{SL}(2, \mathbb{C}))$  and we write

$$(9.1) \quad \int g(a) \mathcal{J}_n(a) d^6 a = \int g(a) f_D(L(a^{-1})x_n) K(x_n, x_{n-1}) \dots \\ \times K(x_2, x_1) f_A(x_1) d^6 a d\Gamma_1 \dots d\Gamma_n.$$

If  $f_A \in \mathcal{O}'_+(\Gamma)$ ,  $f_D \in \mathcal{O}'_-(\Gamma)$  and the kernel  $K$  has the form (7.11), from Propositions 9 and 12 we see that the right-hand side of this equation is meaningful. If moreover we assume

$$(9.2) \quad \begin{cases} e^{-L_1 x} f_A(x) \in \mathcal{S}'(\Gamma), \\ e^{L_1 x} f_D(x) \in \mathcal{S}'(\Gamma), \\ e^{-L_1 \beta} k(\beta) \in \mathcal{S}'(\mathbb{R}) \end{cases} \quad (L_1 > 0),$$

the Laplace transforms  $H_{Ajm}^\lambda$ ,  $H_{Bjm}^{-\lambda}$  and  $k(\lambda)$  are defined for  $\text{Re } \lambda > L_1$ , while the Laplace transforms  $\Phi_{Ajm}^M$  and  $\Phi_{Bjm}^M$  are defined for  $M > L_1$ .



Using the Propositions 8, 11 and 12, we can write the expression (9.1) in the form

$$(9.3) \quad \left\{ \begin{aligned} \int g(a) \mathcal{J}_n(a) d^6 a &= 2i \int_{L-i\infty}^{L+i\infty} \lambda^2 d\lambda \sum_{jmj'm'} G_{jmj'm'}^{0,-\lambda} I_{jmj'm'}^{0\lambda n} \\ &+ 4\pi \sum_{M>L} M \sum_{jmj'm'} G_{jmj'm'}^{M0} I_{jmj'm'}^{M0n}, \\ &(\mathbf{L} > \mathbf{L}_1), \end{aligned} \right.$$

where

$$(9.4) \quad I_{jmj'm'}^{0\lambda n} = (-1)^n H_{A_j, -m}^\lambda [\tilde{k}(\lambda)]^{n-1} H_{B_j, m'}^{-\lambda},$$

$$(9.5) \quad I_{jmj'm'}^{M0n} = (-1)^n \Phi_{A_j, -m}^M [\tilde{k}(M)]^{n-1} \Phi_{B_j, m'}^M.$$

We remember that in the right-hand sides of equations (9.4) and (9.5) one should take into account the variables  $u_i$  and the corresponding integrations, which were understood in equation (1.13). In particular, the expression  $(\tilde{k}(\lambda))^{n-1}$  has to be interpreted as a kernel iterated  $n - 1$  times.

In order to sum over  $n$  to get the inclusive distribution (1.12), we assume that, as it happens in the physically interesting cases, the series

$$(9.6) \quad I_{jmj'm'}^{0\lambda} = \sum_{n=1}^{\infty} I_{jmj'm'}^{0\lambda n}, \quad I_{jmj'm'}^{M0} = \sum_{n=1}^{\infty} I_{jmj'm'}^{M0n},$$

converge for  $\text{Re } \lambda > \hat{L} \geq L_1$  and  $M > \hat{L}$  in such a way that the sum under the integration sign can be performed in equation (9.3). We obtain in this way

$$(9.7) \quad \left\{ \begin{aligned} \int g(a) \mathcal{J}(a) d^6 a &= 2i \int_{L-i\infty}^{L+i\infty} \lambda^2 d\lambda \sum_{jmj'm'} G_{jmj'm'}^{0,-\lambda} I_{jmj'm'}^{0\lambda} \\ &+ 4\pi \sum_{M>L} M \sum_{jmj'm'} G_{jmj'm'}^{M0} I_{jmj'm'}^{M0}, \\ &(\mathbf{L} > \hat{\mathbf{L}}). \end{aligned} \right.$$

If  $\mathcal{J}(a)$  is a sufficiently regular function, equation (9.7) is equivalent to the simpler formula

$$(9.8) \quad \mathcal{J}(a) = 2i \int_{L-i\infty}^{L+i\infty} \lambda^2 d\lambda \sum_{jmj'm'} \mathcal{O}_{jmj'm'}^{0,-\lambda}(a) I_{jmj'm'}^{0\lambda} + 4\pi \sum_{M>L} M \sum_{jmj'm'} \mathcal{O}_{jmj'm'}^{M0}(a) I_{jmj'm'}^{M0}, \quad (\mathbf{L} > \hat{\mathbf{L}})$$

If the function  $\Gamma_{jmj'm'}^{0\lambda}$  can be continued analytically for  $\Re e \lambda \leq \hat{L}$ , one can get in the usual way the asymptotic behaviour of  $\mathcal{J}(a)$  from the singularities of this function. The standard way to obtain this analytic continuation is to write

$$(9.9) \quad \Gamma_{jmj'm'}^{0\lambda} = (-1)^m \int H_{A_j, -m}^\lambda(u) \tilde{h}(\lambda, u, u') \\ \times H_{B_j, m'}^{-\lambda}(u') \frac{1}{2} u' du' \frac{1}{2} u du,$$

where  $\tilde{h}$  is the solution of the multiperipheral integral equation

$$(9.10) \quad \tilde{h}(\lambda, u, u') = 2 u^{-1} \delta(u - u') \\ + \int \tilde{k}(\lambda, u, u'') \tilde{h}(\lambda, u'', u') \frac{1}{2} u'' du''.$$

If the kernel  $\tilde{k}$  is Fredholm, the kernel  $\tilde{h}$  is meromorphic in the half plane  $\Re e \lambda > L_1$  and its poles are just the Lorentz poles.

We remark that equations (9.7) or (9.8) can be interpreted as an harmonic analysis of the distribution  $\mathcal{J}(a)$  on  $SL(2, C)$ . From a general point of view, if  $\mathcal{J}(a)$  is an arbitrary distribution one can only write [17]:

$$(9.11) \quad \int \mathcal{J}(a) g(a) d^6 a = F(G),$$

where  $F$  is a linear functional on the space of the analytic functions  $G_{jmj'm'}^{M\lambda}$ . Equation (9.7) gives a particular explicit expression for the functional  $F$ , which is valid for functions of the form (1.13) and therefore contains some dynamical information that follows from the model we are considering. Remark that this functional is not written in the same form as the one assumed in [17].

At this point, we analyze briefly the dynamical information contained in equations (9.7) and (9.8). We remember that the square of the centre-of-mass energy is given by

$$(9.12) \quad s = (P_{A1} + L(a) P_{B1})^2$$

and therefore the limit of large  $a$  is equivalent to the limit of large  $s$ . In this limit the series in the right-hand side of equation (9.8) is of the order  $s^{-1}$  and therefore can be lumped in the "background integral". The contribution of a Lorentz pole at  $\lambda = \tilde{\lambda} > 0$  behaves asymptotically as  $s^{\tilde{\lambda}-1}$ . Remark that in this class of models only Lorentz poles with  $M = 0$  can appear.

From Proposition 3, we see that  $H_{B_j, m'}^{-\lambda}$  can have poles for  $\lambda = 0, 1, 2, \dots, j'$ , which in general appear also in the expression (9.9). These

are fixed poles at the nonsense points in the Lorentz plane. The matrix elements  $\mathcal{O}_{jmj'm'}^{0,-\lambda}(a)$  have simple zeros for  $\lambda = j + 1, j + 2, \dots, j'$  (if  $j' > j$ ). Therefore the integrand in equation (9.8) has poles at the "nonsense nonsense" points  $\lambda = 1, 2, \dots, \min(j, j')$ . The contributions of these poles have the same nature as the terms of the series in equation (9.8), due to the identity

$$(9.13) \quad \left\{ \begin{aligned} \mathcal{O}_{jmj'm'}^{0,-M}(a) &= \left[ \frac{(j+M)! (j'-M)!}{(j-M)! (j'+M)!} \right]^{1/2} \mathcal{O}_{jmj'm'}^{M0}(a), \\ &(|M| \leq j, |M| \leq j'), \end{aligned} \right.$$

and therefore can be asymptotically included in the background integral.

A more interesting situation occurs when a Lorentz pole is present for integral  $\lambda$ . Then the function  $\mathbb{1}_{jmj'm'}^{0,\lambda}$  has a double pole if  $j' \geq \lambda$ . We remember that the coefficient of the leading term of  $\mathcal{O}_{jmj'm'}^{0,-\lambda}(a)$  has a simple zero for  $\lambda = 0, 1, 2, \dots, j'$ , so that, for any fixed  $j, j'$ , the integrand in equation (9.8) has, in general, a simple pole, as far as the leading term is concerned. In conclusion, we see that the fixed poles have the effect of compensating the nonsense zeros.

This mechanism is physically very important if one assumes that the Pomeron is a Lorentz pole at  $\lambda = 2$ . In fact, if we consider the one-particle inclusive distribution for the process  $A + B \rightarrow \alpha + \text{anything}$ , and we call  $q$  and  $\theta$  the momentum and the production angle of the observed particle in the rest system of the particle B, the inclusive distribution is given by ([7], [32]) :

$$(9.14) \quad \begin{aligned} F(s, q, \theta) &= \frac{1}{2} [s(s - 4m^2)]^{-1/2} \mathcal{J}(a_z(\zeta) u_Y(\theta), q) \\ &\simeq \frac{1}{2} [s(s - 4m^2)]^{-1/2} (-4\pi) \tilde{\lambda}^2 \sum_{j'} \beta_{j'}(q) \mathcal{O}_{00j'0}^{0,-\tilde{\lambda}}(a_z(\zeta) u_Y(\theta)), \end{aligned}$$

where  $\tilde{\lambda}$  is the position of the leading pole. Using the asymptotic properties of the representation matrix elements, we get [29] :

$$(9.15) \quad \begin{aligned} F(s, q, \theta) &\simeq -2\pi s^{-1} (\Gamma(\tilde{\lambda} + 1))^2 \exp[(\tilde{\lambda} - 1)\zeta] \\ &\quad \times \sum_{j'} \beta_{j'}(q) \sqrt{2j' + 1} (\Gamma(\tilde{\lambda} - j') \Gamma(\tilde{\lambda} + j' + 1))^{-1} P_{j'}(\cos \theta). \end{aligned}$$

If  $\tilde{\lambda} = 2$ , the sum over  $j'$  has only the first two terms giving rise to a linear behaviour in  $\cos \theta$ , which is incompatible with the observed

damping in the transverse momentum

$$(9.16) \quad p = q \sin \theta.$$

It is easy to realize that the presence of the fixed pole at  $\lambda = 2$  permits to avoid this unwanted conclusion.

### APPENDIX A

We prove the following result :

LEMMA. — *If  $f(x)$  is a  $C^\infty$  function on  $\Gamma$ , the two sets of semi-norms*

$$(A 1) \quad \sup [\text{ch } \alpha (1 + |\alpha|)^q | P e^{L\alpha} f(x) |]$$

and

$$(A 2) \quad \sup [\text{ch } \alpha (1 + |\alpha|)^q e^{L\alpha} | P f(x) |] \quad (q = 0, 1, 2, \dots),$$

where  $P$  indicates an arbitrary polynomial in the generators (with constant coefficients), are equivalent in the sense that each semi-norm of the kind (A 1) is majorized by a finite sum of semi-norms of the kind (A 2) and vice-versa.

*Proof.* — First we show that, if  $P$  is a polynomial in the generators

$$(A 3) \quad | P e^{L\alpha} | \leq C e^{L\alpha}.$$

This inequality follows from the fact that if  $P$  is of degree  $n$ , we can write

$$(A 4) \quad P e^{L\alpha} = e^{L\alpha} \sum_{p=0}^{2n} (\alpha_0^2 + 1)^{-(1/2)p} \sum_{i_1 i_2 \dots i_p} A_{i_1 i_2 \dots i_p} x_{i_1} x_{i_2} \dots x_{i_p}.$$

This formula holds clearly for  $n = 0$  and can be proved by induction starting from the definitions (4.14) and (4.15) of the generators.

It follows that

$$(A 5) \quad | P e^{L\alpha} f(x) | = \left| \sum_{i=1}^N (P'_i e^{L\alpha})(P_i f(x)) \right| \leq e^{L\alpha} \sum_{i=1}^N C_i | P_i f(x) |.$$

By means of the substitutions  $\exp(L\alpha) f(x) \rightarrow f(x)$ ,  $L \rightarrow -L$ , we get also

$$(A 6) \quad e^{L\alpha} | P f(x) | \leq \sum_{i=1}^N C_i | P_i e^{L\alpha} f(x) |$$

and the Lemma follows immediately.

## APPENDIX B

In this Appendix we study some properties of the function  $\psi(x', \beta)$  defined by equation (7.8). By means of a rotation, we can choose a system of co-ordinates in which

$$(B\ 1) \quad x' = (\text{sh } \alpha', 0, 0, \text{ch } \alpha')$$

and equation (7.8) takes the form

$$(B\ 2) \quad \psi(x', \beta) = \int f(x) R^{-1} dx_1 dx_2,$$

where

$$(B\ 3) \quad \begin{cases} x_0 = \text{ch } \beta \text{ sh } \alpha' + R \text{ ch } \alpha', \\ x_3 = \text{ch } \beta \text{ ch } \alpha' + R \text{ sh } \alpha'; \end{cases}$$

$$(B\ 4) \quad R = [(\text{sh } \beta)^2 + x_1^2 + x_2^2]^{1/2}.$$

If we keep  $x_1, x_2$ , and  $\alpha'$  fixed, from equation (B 3) we get

$$(B\ 5) \quad \frac{\partial}{\partial \beta} f(x) = -R^{-1} \text{sh } \beta \mathbf{L}_z f(x),$$

where  $\mathbf{L}_z$  is the generator of the boosts along the  $x_3$  axis. From a repeated use of this equation, we obtain

$$(B\ 6) \quad \frac{\partial^n}{\partial \beta^n} (R^{-1} f(x)) = R^{-1} \sum_{i=0}^n A_{ni} (R^{-1} \text{ch } \beta, R^{-1} \text{sh } \beta) (\mathbf{L}_z)^i f(x),$$

where  $A_{ni}$  is a polynomial of maximum degree  $n$  in each of its two variables and therefore satisfies an inequality of the kind

$$(B\ 7) \quad |A_{ni}| \leq a_n (\text{th } \beta)^{-n}.$$

Therefore from equations (B 2) and (B 6) we have the inequality

$$(B\ 8) \quad \left| \frac{\partial^n}{\partial \beta^n} \psi(x', \beta) \right| \leq a_n (\text{th } \beta)^{-n} \sum_{i=0}^n \int |(\mathbf{L}_z)^i f(x)| R^{-1} dx_1 dx_2.$$

Now we assume that  $f$  has the properties (7.12) and (7.13). Then, from the Lemma of Appendix A, we have

$$(B\ 9) \quad \left\{ \sum_{i=0}^n |(\mathbf{L}_z)^i f(x)| \leq C_{nq} e^{-L_1 \alpha} (\text{ch } \alpha)^{-1} (1 + |\alpha|)^{-q} \right. \\ \left. (q = 0, 1, 2 \dots), \right.$$

where  $C_{nq}$  is a semi-norm continuous in  $\mathfrak{S}(\Gamma)$  of the function (7.13). Introducing this inequality into equation (B 8), we get the majorization

$$(B\ 10) \left\{ \begin{array}{l} \left| \frac{\partial^n}{\partial \beta^n} \psi(x', \beta) \right| \\ \leq a_n C_{nq} (\text{th } \beta)^{-n} 2\pi (L_1 \text{ ch } x')^{-1} e^{-L_1(x'+\beta)} (1 + x' + \beta)^{-q} \\ (\alpha' + \beta > 0, L_1 > 0), \end{array} \right.$$

and therefore

$$(B\ 11) \left\{ \begin{array}{l} \left| \frac{\partial^n}{\partial \beta^n} \psi(x', \beta) \right| \leq a_n C_{n,p+q} (\text{th } \beta)^{-n} 2\pi \\ \times (L_1 \text{ ch } x')^{-1} e^{-L_1(x'+\beta)} (1 + x')^{-p} (1 + \beta)^{-q} \\ (\alpha' \geq 0, p, q = 0, 1, 2 \dots, L_1 > 0). \end{array} \right.$$

## REFERENCES

- [1] D. AMATI, S. FUBINI and A. STANGHELLINI, *Nuovo Cimento*, vol. 26, 1962, p. 896.
- [2] L. BERTOCCHI, S. FUBINI and M. TONIN, *Nuovo Cimento*, vol. 25, 1962, p. 626.
- [3] C. CEOLIN, F. DUIMIO, S. FUBINI and R. STROFFOLINI, *Nuovo Cimento*, vol. 26, 1962, p. 247.
- [4] R. P. FEYNMAN, *High Energy Collisions*, C. N. Yang *et al.* Ed., New York, 1969, p. 237.
- [5] C. E. DE TAR, *Phys. Rev.*, vol. D 3, 1971, p. 128.
- [6] D. SILVERMAN and C. I. TAN, *Nuovo Cimento*, vol. 2 A, 1971, p. 489; *Phys. Rev.*, vol. D 3, 1971, p. 991.
- [7] A. BASSETTO, L. SERTORIO and M. TOLLER, *Nuclear Phys.*, vol. B 34, 1971, p. 1.
- [8] G. F. CHEW, T. ROGERS and D. S. SNIDER, *Phys. Rev.*, vol. D 2, 1970, p. 765.
- [9] A. BASSETTO and F. PACCANONI, *Nuovo Cimento*, vol. 2 A, 1971, p. 306.
- [10] G. F. CHEW, M. L. GOLDBERGER and F. E. LOW, *Phys. Rev. Lett.*, vol. 22, 1969, p. 208.
- [11] G. F. CHEW and C. DE TAR, *Phys. Rev.*, vol. 180, 1969, p. 1577.
- [12] A. H. MUELLER and I. J. MUZINICH, *Ann. Phys.* (N. Y.), vol. 57, 1970, p. 20.
- [13] M. CIAFALONI and C. DE TAR, *Phys. Rev.*, vol. D 1, 1970, p. 2917.
- [14] M. TOLLER, *Nuovo Cimento*, vol. 37, 1965, p. 631.
- [15] A. H. MUELLER, *Phys. Rev.*, vol. D 2, 1970, p. 2963.
- [16] H. D. I. ABARBANEL, *Phys. Rev.*, vol. D 3, 1971, p. 2227.
- [17] M. TOLLER, *Nuovo Cimento*, vol. 53 A, 1968, p. 671.
- [18] L. SCHWARTZ, *Théorie des Distributions*, Paris, 1966.
- [19] I. M. GEL'FAND, M. I. GRAEV and N. YA. VILENKIN, *Generalized Functions*, vol. 5, New York and London, 1966.
- [20] J. S. ZMUIDZINAS, *J. Math. Phys.*, vol. 7, 1966, p. 764.
- [21] S. NUSSINOV and J. ROSNER, *J. Math. Phys.*, vol. 7, 1966, p. 1670.

- [22] H. D. I. ABARBANEL and L. M. SAUNDERS, *Phys. Rev.*, vol. D 2, 1970, p. 711.
- [23] H. D. I. ABARBANEL and L. M. SAUNDERS, *Ann. Phys. (N. Y.)*, vol. 69, 1972, p. 583.
- [24] L. SERTORIO and M. TOLLER, *Nuovo Cimento*, vol. 33, 1964, p. 413.
- [25] S. FERRARA and G. MATTIOLI, *Ann. Phys. (N. Y.)*, vol. 59, 1970, p. 444.
- [26] S. FERRARA and G. MATTIOLI, *Nuovo Cimento*, vol. 65 A, 1970, p. 25.
- [27] W. RÜHL, *The Lorentz Group and Harmonic Analysis*, New York, 1970.
- [28] M. A. NAIMARK, *Linear Representations of the Lorentz Group*, London, 1964.
- [29] A. SCIARRINO and M. TOLLER, *J. Math. Phys.*, vol. 8, 1967, p. 1252.
- [30] M. E. ROSE, *Elementary Theory of Angular Momentum*, New York, 1957.
- [31] A. ERDELYI, W. MAGNUS, F. OBERHETTINGER and F. G. TRICOMI, *Higher Transcendental Functions*, vol. 1, New York, 1953.
- [32] A. BASSETTO and M. TOLLER, *Nuovo Cimento Letters*, vol. 2, 1971, p. 409, Eq. (10).

(Manuscrit reçu le 5 juin 1972.)