

ANNALES MATHÉMATIQUES



BLAISE PASCAL

OLIVIER GENESTE, JEAN-YVES HÉE & LUIS PARIS

Root systems, symmetries and linear representations of Artin groups

Volume 26, n° 1 (2019), p. 25-54.

http://ambp.centre-mersenne.org/item?id=AMBP_2019__26_1_25_0

© Université Clermont Auvergne, Laboratoire de mathématiques Blaise Pascal, 2019,
Certains droits réservés.



Cet article est mis à disposition selon les termes de la licence

CREATIVE COMMONS ATTRIBUTION – PAS DE MODIFICATION 4.0 FRANCE.

<http://creativecommons.org/licenses/by-nd/4.0/fr/>

L'accès aux articles de la revue « Annales mathématiques Blaise Pascal » (<http://ambp.centre-mersenne.org/>), implique l'accord avec les conditions générales d'utilisation (<http://ambp.centre-mersenne.org/legal/>).

*Publication éditée par le laboratoire de mathématiques Blaise Pascal
de l'université Clermont Auvergne, UMR 6620 du CNRS
Clermont-Ferrand — France*



Article mis en ligne dans le cadre du
Centre de diffusion des revues académiques de mathématiques
<http://www.centre-mersenne.org/>

Root systems, symmetries and linear representations of Artin groups

OLIVIER GENESTE
JEAN-YVES HÉE
LUIS PARIS

Abstract

Let Γ be a Coxeter graph, let W be its associated Coxeter group, and let G be a group of symmetries of Γ . Recall that, by a theorem of Hée and Mühlherr, W^G is a Coxeter group associated to some Coxeter graph $\widehat{\Gamma}$. We denote by Φ^+ the set of positive roots of Γ and by $\widehat{\Phi}^+$ the set of positive roots of $\widehat{\Gamma}$. Let E be a vector space over a field \mathbb{K} having a basis in one-to-one correspondence with Φ^+ . The action of G on Γ induces an action of G on Φ^+ , and therefore on E . We show that E^G contains a linearly independent family of vectors naturally in one-to-one correspondence with $\widehat{\Phi}^+$ and we determine exactly when this family is a basis of E^G . This question is motivated by the construction of Krammer's style linear representations for non simply laced Artin groups.

Systèmes de racines, symétries et représentations linéaires des groupes d'Artin

Résumé

Soient Γ un graphe de Coxeter, W son groupe de Coxeter associé et G un groupe de symétries de Γ . Rappelons que, par un théorème de Hée et Mühlherr, W^G est un groupe de Coxeter associé à un certain graphe de Coxeter $\widehat{\Gamma}$. On note Φ^+ l'ensemble des racines positives de Γ et $\widehat{\Phi}^+$ l'ensemble des racines positives de $\widehat{\Gamma}$. Soit E un espace vectoriel sur un corps \mathbb{K} ayant une base en bijection avec Φ^+ . L'action de G sur Γ induit une action de G sur Φ^+ , et donc sur E . Nous montrons que E^G contient une famille libre de vecteurs naturellement en bijection avec $\widehat{\Phi}^+$ et nous déterminons exactement quand cette famille est une base de E^G . Cette question est motivée par la construction de représentations linéaires à la Krammer de groupes d'Artin non simplement lacés.

1. Introduction

1.1. Motivation

Bigelow [1] and Krammer [20] proved that the braid groups are linear answering a historical question in the subject. More precisely, they proved that some linear representation $\psi : \mathcal{B}_n \rightarrow \text{GL}(E)$ of the braid group \mathcal{B}_n previously introduced by Lawrence [22] is faithful. A useful information for us is that E is a vector space over the field $\mathbb{K} = \mathbb{Q}(q, z)$ of rational functions in two variables q, z over \mathbb{Q} , and has a natural basis of the form $\{e_{i,j} \mid 1 \leq i < j \leq n\}$.

Keywords: Artin group, linear representation, Coxeter group, root system.

2010 Mathematics Subject Classification: 20F36.

Let Γ be a Coxeter graph, let W_Γ be its associated Coxeter group, let A_Γ be its associated Artin group, and let A_Γ^+ be its associated Artin monoid. The Coxeter graph Γ is called of *spherical type* if W_Γ is finite, it is called *simply laced* if none of its edges is labelled, and it is called *triangle free* if there are no three vertices in Γ two by two connected by edges. Shortly after the release of the papers by Bigelow [1] and Krammer [20], Digne [12] and independently Cohen–Wales [6] extended Krammer’s [20] constructions and proofs to the Artin groups associated with simply laced Coxeter graphs of spherical type, and, afterwards, Paris [25] extended them to all the Artin groups associated to simply laced triangle free Coxeter graphs (see also Hée [16] for a simplified proof of the faithfulness of the representation). More precisely, for a finite simply laced triangle free Coxeter graph Γ , they constructed a linear representation $\psi : A_\Gamma \rightarrow \text{GL}(E)$, they showed that this representation is always faithful on the Artin monoid A_Γ^+ , and they showed that it is faithful on the whole group A_Γ if Γ is of spherical type. What is important to know here is that E is still a vector space over $\mathbb{K} = \mathbb{Q}(q, z)$ and that E has a natural basis $\mathcal{B} = \{e_\beta \mid \beta \in \Phi^+\}$ in one-to-one correspondence with the set Φ^+ of positive roots of Γ .

The question that motivated the beginning of the present study is to find a way to extend the construction of this linear representation to other Artin groups, or, at least, to some Artin groups whose Coxeter graphs are not simply laced and triangle free. A first approach would be to extend Paris’ [25] construction to other Coxeter graphs that are not simply laced and triangle free. Unfortunately, explicit calculations on simple examples convinced us that this approach does not work.

However, an idea for constructing such linear representations for some Artin groups associated to non simply laced Coxeter graphs can be found in Digne [12]. In that paper Digne takes a Coxeter graph Γ of type A_{2n+1} , D_n , or E_6 and consider some specific symmetry g of Γ . By Hée [14] and Mühlherr [24] the subgroup W_Γ^g of fixed elements by g is itself a Coxeter group associated with a precise Coxeter graph $\widehat{\Gamma}$. By Michel [23], Crisp [7, 8] and Dehornoy–Paris [10], the subgroup A_Γ^g of A_Γ of fixed elements by g is an Artin group associated with $\widehat{\Gamma}$. On the other hand the symmetry g acts on the basis \mathcal{B} of E and the linear representation $\psi : A_\Gamma \rightarrow \text{GL}(E)$ is equivariant in the sense that $\psi(g(a)) = g\psi(a)g^{-1}$ for all $a \in A_\Gamma$. It follows that ψ induces a linear representation $\psi^g : A_{\widehat{\Gamma}} \rightarrow \text{GL}(E^g)$, where E^g denotes the subspace of fixed vectors of E under the action of g . Then Digne [12] proves that ψ^g is faithful and that E^g has a “natural” basis in one-to-one correspondence with the set $\widehat{\Phi}^+$ of positive roots of $\widehat{\Gamma}$. This defines a linear representation for the Artin groups associated with the Coxeter graphs B_n ($n \geq 2$), G_2 and F_4 .

Let Γ be a finite simply laced triangle free Coxeter graph and let G be a non-trivial group of symmetries of Γ . Then G acts on the groups W_Γ and A_Γ and on the monoid A_Γ^+ .

We know by Hée [14] and Mühlherr [24] (see also Crisp [7, 8], Geneste–Paris [13] and Theorem 2.5) that W_Γ^G is the Coxeter group associated with some precise Coxeter graph $\widehat{\Gamma}$. Moreover, by Crisp [7, 8], the monoid A_Γ^{+G} is an Artin monoid associated with $\widehat{\Gamma}$ and in many cases the group A_Γ^G is an Artin group associated with $\widehat{\Gamma}$. On the other hand, G acts on the basis \mathcal{B} of E , and the linear representation $\psi : A_\Gamma \rightarrow \text{GL}(E)$ is equivariant in the sense that $\psi(g(a)) = g\psi(a)g^{-1}$ for all $a \in A_\Gamma$ and all $g \in G$. Thus, ψ induces a linear representation $\psi^G : A_{\widehat{\Gamma}} \rightarrow \text{GL}(E^G)$, where $E^G = \{x \in E \mid g(x) = x \text{ for all } g \in G\}$. We also know by Castella [3, 5] that the induced representation $\psi^G : A_{\widehat{\Gamma}} \rightarrow \text{GL}(E^G)$ is faithful on the monoid $A_{\widehat{\Gamma}}^+$. So, it remains to determine when E^G has a “natural” basis in one-to-one correspondence with the set $\widehat{\Phi}^+$ of positive roots of $\widehat{\Gamma}$. The purpose of this paper is to answer this question.

1.2. Statements

The simply laced triangle free Artin groups and the linear representations $\psi : A_\Gamma \rightarrow \text{GL}(E)$ form the framework of our motivation, but they are not needed for the rest of the paper. We will also work with any Coxeter graph, which may have labels and infinitely many vertices. So, let Γ be a Coxeter graph associated with a Coxeter matrix $M = (m_{s,t})_{s,t \in S}$, let \mathbb{K} be a field, and let E be a vector space over \mathbb{K} having a basis $\mathcal{B} = \{e_\beta \mid \beta \in \Phi^+\}$ in one-to-one correspondence with the set Φ^+ of positive roots of Γ .

A *symmetry* of Γ is defined to be a permutation g of S satisfying $m_{g(s),g(t)} = m_{s,t}$ for all $s, t \in S$. The group of symmetries of Γ will be denoted by $\text{Sym}(\Gamma)$. Let G be a subgroup of $\text{Sym}(\Gamma)$. Again, we know by Hée [14] and Mühlherr [24] that W_Γ^G is the Coxeter group associated with some Coxeter graph $\widehat{\Gamma}$. On the other hand, G acts on the set Φ^+ of positive roots of Γ and therefore on E . Let $\widehat{\Phi}^+$ be the set of positive roots of $\widehat{\Gamma}$. In this paper we show that E^G contains a “natural” linearly independent set $\widehat{\mathcal{B}} = \{\widehat{e}_{\widehat{\beta}} \mid \widehat{\beta} \in \widehat{\Phi}^+\}$ in one-to-one correspondence with the set $\widehat{\Phi}^+$ and we determine when $\widehat{\mathcal{B}}$ is a basis of E^G .

From now on we will say that the pair (Γ, G) has the $\widehat{\Phi}^+$ -*basis property* if the above mentioned subset $\widehat{\mathcal{B}}$ is a basis of E^G .

We proceed in three steps to determine the pairs (Γ, G) that have the $\widehat{\Phi}^+$ -basis property. In a first step (see Subsection 4.1) we show that it suffices to consider the case where all the orbits of S under the action of G are finite. Let S_{fin} denote the union of the finite orbits of S under the action of G , and let Γ_{fin} denote the full subgraph of Γ spanned by S_{fin} . Each symmetry $g \in G$ stabilizes S_{fin} , hence induces a symmetry of Γ_{fin} . We denote by G_{fin} the subgroup of $\text{Sym}(\Gamma_{\text{fin}})$ of all these symmetries. In Subsection 4.1 we will prove the following.

Theorem 1.1. *The pair (Γ, G) has the $\widehat{\Phi}^+$ -basis property if and only if the pair $(\Gamma_{\text{fin}}, G_{\text{fin}})$ has the $\widehat{\Phi}^+$ -basis property.*

By Theorem 1.1 we can assume that all the orbits of S under the action of G are finite. In a second step (see Subsection 4.2) we show that it suffices to consider the case where Γ is connected. Let $\Gamma_i, i \in I$, be the connected components of Γ . For each $i \in I$ we denote by $\text{Stab}_G(\Gamma_i)$ the stabilizer of Γ_i in G . Each symmetry $g \in \text{Stab}_G(\Gamma_i)$ induces a symmetry of Γ_i . We denote by G_i the subgroup of $\text{Sym}(\Gamma_i)$ of all these symmetries. In Subsection 4.2 we will prove the following.

Theorem 1.2. *Suppose that all the orbits of S under the action of G are finite. Then the pair (Γ, G) has the $\widehat{\Phi}^+$ -basis property if and only if for each $i \in I$ the pair (Γ_i, G_i) has the $\widehat{\Phi}^+$ -basis property.*

By Theorem 1.2 we can also assume that Γ is connected. In a third step (see Subsection 4.3 and Subsection 4.4) we determine all the pairs (Γ, G) that have the $\widehat{\Phi}^+$ -basis property with Γ connected and all the orbits of S under the action of G being finite.

One can associate with Γ a real vector space $V = \bigoplus_{s \in S} \mathbb{R}\alpha_s$ whose basis is in one-to-one correspondence with S and a *canonical bilinear form* $\langle \cdot, \cdot \rangle : V \times V \rightarrow \mathbb{R}$. These objects will be defined in Subsection 2.1. We say that Γ is of *spherical type* if S is finite and $\langle \cdot, \cdot \rangle$ is positive definite, and we say that Γ is of *affine type* if S is finite and $\langle \cdot, \cdot \rangle$ is positive but not positive definite. A classification of the connected spherical and affine type Coxeter graphs can be found in Bourbaki [2]. In this paper we use the notations A_m ($m \geq 1$), \dots , $I_2(p)$ ($p = 5$ or $p \geq 7$) of Bourbaki [2, Chap. VI, §4, No 1, Thm. 1] for the connected Coxeter graphs of spherical type, and the notations $\widetilde{A}_1, \widetilde{A}_m$ ($m \geq 2$), \dots , \widetilde{G}_2 of Bourbaki [2, Chap. VI, §4, No 2, Thm. 4] for the connected Coxeter graphs of affine type. Moreover, we use the same numbering of the vertices of these Coxeter graphs as the one in Bourbaki [2, Planches] with the convention that the unnumbered vertex in Bourbaki [2, Planches] is here labelled with 0.

To the Coxeter graphs of spherical type and affine type we must add the two infinite Coxeter graphs ${}_{\infty}A_{\infty}$ and D_{∞} drawn in Figure 1.1. The Coxeter graph A_{∞} of the figure does not appear in the statement of Theorem 1.3 but it will appear in its proof. These Coxeter graphs are part of the family of so-called *locally spherical Coxeter graphs* studied by Hée [15, Texte 10].

Now, the conclusion of the third step which is in some sense the main result of the paper is the following theorem, proved in Subsection 4.4.

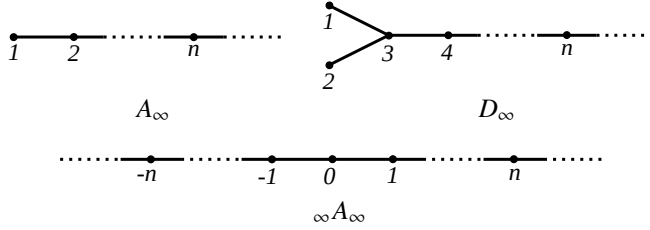

FIGURE 1.1. Locally spherical Coxeter graphs

Theorem 1.3. *Suppose that Γ is connected, G is non-trivial and all the orbits of S under the action of G are finite. Then (Γ, G) has the $\widehat{\Phi}^+$ -basis property if and only if (Γ, G) is up to isomorphism one of the following pairs (see Figure 1.2, Figure 1.3 and Figure 1.4).*

- (i) $\Gamma = A_{2m+1}$ ($m \geq 1$) and $G = \langle g \rangle$ where

$$g(s_i) = s_{2m+2-i} \quad (1 \leq i \leq 2m+1).$$

- (ii) $\Gamma = D_m$ ($m \geq 4$) and $G = \langle g \rangle$ where

$$g(s_i) = s_i \quad (1 \leq i \leq m-2), \quad g(s_{m-1}) = s_m, \quad g(s_m) = s_{m-1}.$$

- (iii) $\Gamma = D_4$ and $\langle g_1 \rangle \subset G \subset \langle g_1, g_2 \rangle$ where

$$\begin{aligned} g_1(s_1) &= s_3, & g_1(s_2) &= s_2, & g_1(s_3) &= s_4, & g_1(s_4) &= s_1, \\ g_2(s_1) &= s_1, & g_2(s_2) &= s_2, & g_2(s_3) &= s_4, & g_2(s_4) &= s_3. \end{aligned}$$

- (iv) $\Gamma = E_6$ and $G = \langle g \rangle$ where

$$g(s_1) = s_6, \quad g(s_2) = s_2, \quad g(s_3) = s_5, \quad g(s_4) = s_4, \quad g(s_5) = s_3, \quad g(s_6) = s_1.$$

- (v) $\Gamma = \widetilde{A}_{2m+1}$ ($m \geq 1$) and $G = \langle g \rangle$ where

$$g(s_0) = s_0, \quad g(s_i) = s_{2m+2-i} \quad (1 \leq i \leq 2m+1).$$

- (vi) $\Gamma = \widetilde{D}_m$ ($m \geq 4$) and $G = \langle g \rangle$ where

$$g(s_i) = s_i \quad (0 \leq i \leq m-2), \quad g(s_{m-1}) = s_m, \quad g(s_m) = s_{m-1}.$$

- (vii) $\Gamma = \widetilde{D}_4$ and $\langle g_1 \rangle \subset G \subset \langle g_1, g_2 \rangle$ where

$$\begin{aligned} g_1(s_0) &= s_0, & g_1(s_1) &= s_3, & g_1(s_2) &= s_2, & g_1(s_3) &= s_4, & g_1(s_4) &= s_1, \\ g_2(s_0) &= s_0, & g_2(s_1) &= s_1, & g_2(s_2) &= s_2, & g_2(s_3) &= s_4, & g_2(s_4) &= s_3. \end{aligned}$$

(viii) $\Gamma = \widetilde{E}_6$ and $G = \langle g \rangle$ where

$$g(s_0) = s_0, g(s_1) = s_6, g(s_2) = s_2, g(s_3) = s_5, g(s_4) = s_4, g(s_5) = s_3, g(s_6) = s_1.$$

(ix) $\Gamma = {}_\infty A_\infty$ and $G = \langle g \rangle$ where

$$g(s_i) = s_{-i} \quad (i \in \mathbb{Z}).$$

(x) $\Gamma = D_\infty$ and $G = \langle g \rangle$ where

$$g(s_1) = s_2, \quad g(s_2) = s_1, \quad g(s_i) = s_i \quad (i \geq 3).$$

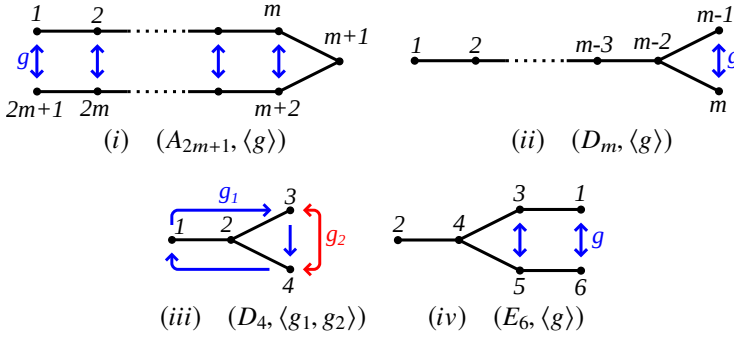

FIGURE 1.2. Pairs with the $\widehat{\Phi}^+$ -basis property: spherical type cases

1.3. Linear representations

We return to our initial motivation before starting the proofs. Recall that a Coxeter graph Γ is called *simply laced* if $m_{s,t} \in \{2, 3\}$ for all $s, t \in S, s \neq t$, and that Γ is called *triangle free* if there are no three distinct vertices $s, t, r \in S$ such that $m_{s,t}, m_{t,r}, m_{r,s} \geq 3$. Suppose that Γ is a finite, simply laced and triangle free Coxeter graph. Let A_Γ be the Artin group and A_Γ^+ be the Artin monoid associated with Γ . Suppose that $\mathbb{K} = \mathbb{Q}(q, z)$ and E is a vector space over \mathbb{K} having a basis $\mathcal{B} = \{e_\alpha \mid \alpha \in \Phi^+\}$ in one-to-one correspondence with the set Φ^+ of positive roots of Γ . By Krammer [20], Cohen–Wales [6], Digne [12] and Paris [25], there is a linear representation $\psi : A_\Gamma \rightarrow \text{GL}(E)$ which is faithful if Γ is of spherical type and which is always faithful on the monoid A_Γ^+ . Let G be a group of symmetries of Γ . Recall from Subsection 1.1 that W_Γ^G is a Coxeter group associated with a precise Coxeter graph $\widehat{\Gamma}$ and by Crisp [7, 8] we have $(A_\Gamma^+)^G = A_{\widehat{\Gamma}}^+$. Then G acts

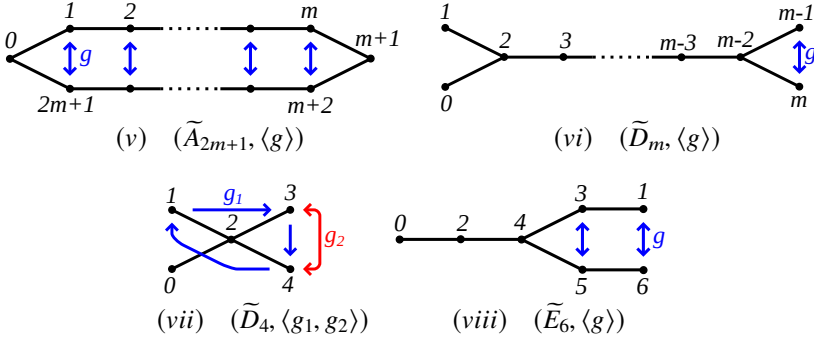

FIGURE 1.3. Pairs with the $\widehat{\Phi}^+$ -basis property: affine type cases

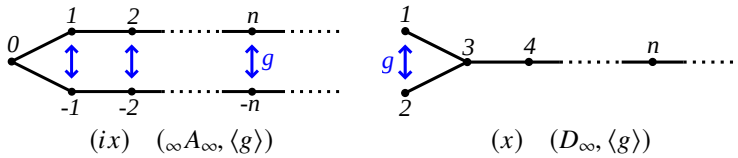

FIGURE 1.4. Pairs with the $\widehat{\Phi}^+$ -basis property: locally spherical type cases

on E , the linear representation ψ is equivariant, and it induces a linear representation $\psi^G : A_{\widehat{\Gamma}} \rightarrow GL(E^G)$. By Castella [3, 5] this representation is always faithful on $A_{\widehat{\Gamma}}^+$ and is faithful on the whole $A_{\widehat{\Gamma}}$ if Γ is of spherical type.

One can find an explicit description of $\widehat{\Gamma}$ in Crisp [7, 8] and in Geneste–Paris [13]. In particular, we have $\widehat{\Gamma} = B_{m+1}$ in Case (i) of Theorem 1.3, we have $\widehat{\Gamma} = B_{m-1}$ in Case (ii), $\widehat{\Gamma} = G_2$ in Case (iii), $\widehat{\Gamma} = F_4$ in Case (iv), $\widehat{\Gamma} = \widetilde{C}_{m+1}$ if $m \geq 2$ and $\widehat{\Gamma} = \widetilde{B}_2$ if $m = 1$ in Case (v), $\widehat{\Gamma} = \widetilde{B}_{m-1}$ in Case (vi), $\widehat{\Gamma} = \widetilde{G}_2$ in Case (vii), and $\widehat{\Gamma} = \widetilde{F}_4$ in Case (viii).

So, concerning a description of a linear representation $\psi : A_{\Gamma} \rightarrow GL(E)$ as above, where E has a given basis $\mathcal{B} = \{e_{\alpha} \mid \alpha \in \Phi^+\}$ in one-to-one correspondence with the set Φ^+ of positive roots of Γ , for Γ of spherical or affine type, the situation is as follows. For the following Coxeter graphs of spherical type the construction is done and the representation is faithful on the whole group A_{Γ} .

- A_m , ($m \geq 1$): original work of Krammer [20].

- D_m ($m \geq 4$), E_6 , E_7 , E_8 : due to Digne [12] and independently to Cohen–Wales [6].
- B_m ($m \geq 2$), F_4 , G_2 : due to Digne [12].

Such representations for the Coxeter graphs H_3 , H_4 and $I_2(p)$ ($p = 5$ or $p \geq 7$) are unknown. For the following Coxeter graphs of affine type the construction is done and the representation is faithful on the Artin monoid A_Γ^+ .

- \tilde{A}_m ($m \geq 3$), \tilde{D}_m ($m \geq 4$), \tilde{E}_6 , \tilde{E}_7 , \tilde{E}_8 : due to Paris [25].
- \tilde{A}_2 : due to Castella [4].
- \tilde{B}_m ($m \geq 2$), \tilde{C}_m ($m \geq 3$), \tilde{F}_4 , \tilde{G}_2 : due Castella [3, 5] for the construction of the representation $\psi : A_\Gamma \rightarrow \text{GL}(E)$ and for the proof of the faithfulness of ψ on A_Γ^+ , and due to the present work for an explicit construction of a basis in one-to-one correspondence with Φ^+ .

Curiously a construction for the remaining Coxeter graph of affine type, \tilde{A}_1 , is unknown.

1.4. Organization of the paper

The paper is organized as follows. In Subsection 2.1 and Subsection 2.2 we give preliminaries on root systems and symmetries. In Section 3 we define the subset $\tilde{\mathcal{B}} = \{\tilde{\rho}_{\tilde{\beta}} \mid \tilde{\beta} \in \tilde{\Phi}^+\}$ of E^G . Section 4 is dedicated to the proofs. Theorem 1.1 is proved in Subsection 4.1 and Theorem 1.2 is proved in Subsection 4.2. The proof of Theorem 1.3 is divided into two parts. In a first part (see Subsection 4.3) we show that, under the assumptions “finite orbits and Γ connected”, the $\tilde{\Phi}^+$ -basis property is quite restrictive. More precisely we prove the following.

Proposition 1.4. *Suppose that Γ is a connected Coxeter graph, G is a non-trivial group of symmetries of Γ , and all the orbits of S under the action of G are finite. If (Γ, G) has the $\tilde{\Phi}^+$ -basis property, then Γ is one of the following Coxeter graphs: A_{2m+1} ($m \geq 1$), D_m ($m \geq 4$), E_6 , \tilde{A}_{2m+1} ($m \geq 1$), \tilde{D}_m ($m \geq 4$), \tilde{E}_6 , \tilde{E}_7 , ${}_\infty A_\infty$, D_∞ .*

In a second part (see Subsection 4.4) we study all the possible pairs (Γ, G) with Γ in the list of Proposition 1.4 and G non-trivial to prove Theorem 1.3.

2. Preliminaries

2.1. Root systems

Let S be a (finite or infinite) set. A *Coxeter matrix* on S is a square matrix $M = (m_{s,t})_{s,t \in S}$ indexed by the elements of S with coefficients in $\mathbb{N} \cup \{\infty\}$, such that $m_{s,s} = 1$ for all $s \in S$, and $m_{s,t} = m_{t,s} \geq 2$ for all $s, t \in S$, $s \neq t$. This matrix is represented by its *Coxeter graph*, Γ , defined as follows. The set of vertices of Γ is S , two vertices s, t are connected by an edge if $m_{s,t} \geq 3$, and this edge is labelled with $m_{s,t}$ if $m_{s,t} \geq 4$.

The *Coxeter group* associated with Γ is the group $W = W_\Gamma$ defined by the presentation

$$W = \langle S \mid s^2 = 1 \text{ for all } s \in S, (st)^{m_{s,t}} = 1 \text{ for all } s, t \in S, s \neq t \text{ and } m_{s,t} \neq \infty \rangle.$$

The pair (W, S) is called the *Coxeter system* associated with Γ .

There are several notions of “root systems” attached to all Coxeter groups. The most commonly used is that defined by Deodhar [11] and taken up by Humphreys [17]. As Geneste–Paris [13] pointed out, this definition is not suitable for studying symmetries of Coxeter graphs. In that case it is better to take the more general definition given by Krammer [19, 21] and taken up by Davis [9], or the even more general one given by Hée [14]. We will use the latter in this paper.

We call *root prebasis* a quadruple $\mathbb{B} = (S, V, \Pi, \mathcal{R})$, where S is a (finite or infinite) set, $\Pi = \{\alpha_s \mid s \in S\}$ is a set in one-to-one correspondence with S , $V = \bigoplus_{s \in S} \mathbb{R}\alpha_s$ is a real vector space with Π as a basis, and $\mathcal{R} = \{\sigma_s \mid s \in S\}$ is a collection of linear reflections of V such that $\sigma_s(\alpha_s) = -\alpha_s$ for all $s \in S$. For all $s, t \in S$ we denote by $m_{s,t}$ the order of $\sigma_s \sigma_t$. Then $M = (m_{s,t})_{s,t \in S}$ is a Coxeter matrix. The Coxeter group of this matrix is denoted by $W(\mathbb{B})$. We have a linear representation $f : W(\mathbb{B}) \rightarrow \text{GL}(V)$ which sends s to σ_s for all $s \in S$. Since we do not need to specify the map f in general, for $w \in W$ and $x \in V$, the vector $f(w)(x)$ will be simply written $w(x)$. We set $\Phi(\mathbb{B}) = \{w(\alpha_s) \mid s \in S \text{ and } w \in W\}$ and we denote by $\Phi(\mathbb{B})^+$ (resp. $\Phi(\mathbb{B})^-$) the set of elements $\beta \in \Phi(\mathbb{B})$ that are written $\beta = \sum_{s \in S} \lambda_s \alpha_s$ with $\lambda_s \geq 0$ (resp. $\lambda_s \leq 0$) for all $s \in S$. We say that \mathbb{B} is a *root basis* if we have the disjoint union $\Phi(\mathbb{B}) = \Phi(\mathbb{B})^+ \sqcup \Phi(\mathbb{B})^-$. In that case $\Phi(\mathbb{B})$ is called a *root system* and the elements of $\Phi(\mathbb{B})^+$ (resp. $\Phi(\mathbb{B})^-$) are called *positive roots* (resp. *negative roots*). Finally, we say that \mathbb{B} is a *reduced root basis* and that $\Phi(\mathbb{B})$ is a *reduced root system* if, in addition, we have $\mathbb{R}\alpha_s \cap \Phi(\mathbb{B}) = \{\alpha_s, -\alpha_s\}$ for all $s \in S$.

Example. Let Γ be a Coxeter graph associated with a Coxeter matrix $M = (m_{s,t})_{s,t \in S}$. As before, we set $\Pi = \{\alpha_s \mid s \in S\}$ and $V = \bigoplus_{s \in S} \mathbb{R}\alpha_s$. We define a symmetric bilinear form $\langle \cdot, \cdot \rangle : V \times V \rightarrow \mathbb{R}$ by

$$\langle \alpha_s, \alpha_t \rangle = \begin{cases} -2 \cos(\pi/m_{s,t}) & \text{if } m_{s,t} \neq \infty, \\ -2 & \text{if } m_{s,t} = \infty. \end{cases}$$

For each $s \in S$ we define a reflection $\sigma_s : V \rightarrow V$ by $\sigma_s(x) = x - \langle \alpha_s, x \rangle \alpha_s$ and we set $\mathcal{R} = \{\sigma_s \mid s \in S\}$. By Deodhar [11], $\mathbb{B} = (S, V, \Pi, \mathcal{R})$ is a root basis and, by Bourbaki [2], $W_\Gamma = W(\mathbb{B})$ and the representation $f : W_\Gamma \rightarrow \text{GL}(V)$ is faithful. This root basis is reduced since we have $\langle \beta, \beta \rangle = 2$ for all $\beta \in \Phi(\mathbb{B})$. It is called the *canonical root basis* of Γ and the bilinear form $\langle \cdot, \cdot \rangle$ is called the *canonical bilinear form* of Γ .

In this subsection we give the results on root systems that we will need, and we refer to Hée [14] for the proofs and more results.

Theorem 2.1 (Hée [14]). *Let $\mathbb{B} = (S, V, \Pi, \mathcal{R})$ be a root basis. Then the induced linear representation $f : W(\mathbb{B}) \rightarrow \text{GL}(V)$ is faithful.*

Let (W, S) be a Coxeter system. The word length of an element $w \in W$ with respect to S will be denoted by $\text{lg}(w) = \text{lg}_S(w)$. The set of *reflections* of (W, S) is defined to be $R = \{wsw^{-1} \mid w \in W \text{ and } s \in S\}$. The following explains why the basis $\mathcal{B} = \{e_\beta \mid \beta \in \Phi^+\}$ of our vector space E will depend only on the Coxeter graph (or on the Coxeter system) and not on the root system.

Theorem 2.2 (Hée [14]). *Let $\mathbb{B} = (S, V, \Pi, \mathcal{R})$ be a reduced root basis, let $W = W(\mathbb{B})$, and let $\Phi = \Phi(\mathbb{B})$. Let R be the set of reflections of (W, S) . Let $\beta \in \Phi$. Let $w \in W$ and $s \in S$ such that $w(\alpha_s) = \beta$. We have $\beta \in \Phi^+$ if and only if $\text{lg}(ws) > \text{lg}(w)$. In that case the element $\varpi(\beta) = wsw^{-1} \in R$ does not depend on the choice of w and s . Moreover, the map $\varpi : \Phi^+ \rightarrow R$ defined in this way is a one-to-one correspondence.*

Let Γ be a Coxeter graph and let (W, S) be its associated Coxeter system. For $X \subset S$ we denote by Γ_X the full subgraph of Γ spanned by X and by W_X the subgroup of W generated by X . By Bourbaki [2], (W_X, X) is the Coxeter system of Γ_X . If $\mathbb{B} = (S, V, \Pi, \mathcal{R})$ is a reduced root basis, then we denote by V_X the vector subspace of V spanned by $\Pi_X = \{\alpha_s \mid s \in X\}$ and we set $\mathcal{R}_X = \{\sigma_s|_{V_X} \mid s \in X\}$.

Proposition 2.3 (Hée [14]). *Let $\mathbb{B} = (S, V, \Pi, \mathcal{R})$ be a reduced root basis and let $X \subset S$. Let $W = W(\mathbb{B})$. Then $\sigma_s(V_X) = V_X$ for all $s \in X$, the quadruple $\mathbb{B}_X = (X, V_X, \Pi_X, \mathcal{R}_X)$ is a reduced root basis, $\Phi(\mathbb{B}_X) = \Phi(\mathbb{B}) \cap V_X$, and $W_X = W(\mathbb{B}_X)$.*

The following is proved in Bourbaki [2] and is crucial in many works on Coxeter groups. It is important to us as well.

Proposition 2.4 (Bourbaki [2]). *The following conditions on an element $w_0 \in W$ are equivalent.*

- (i) *For all $u \in W$ we have $\text{lg}(w_0) = \text{lg}(u) + \text{lg}(u^{-1}w_0)$.*
- (ii) *For all $s \in S$ we have $\text{lg}(sw_0) < \text{lg}(w_0)$.*

Moreover, such an element w_0 exists if and only if W is finite. If w_0 satisfies (i) and/or (ii) then w_0 is unique, w_0 is involutive (i.e. $w_0^2 = 1$), and $w_0 S w_0 = S$.

When W is finite the element w_0 in Proposition 2.4 is called *the longest element* of W .

2.2. Symmetries

Recall that a *symmetry* of a Coxeter graph Γ associated with a Coxeter matrix $M = (m_{s,t})_{s,t \in S}$ is a permutation g of S satisfying $m_{g(s),g(t)} = m_{s,t}$ for all $s, t \in S$. Recall also that $\text{Sym}(\Gamma)$ denotes the group of all symmetries of Γ . Let G be a subgroup of $\text{Sym}(\Gamma)$. We denote by \mathcal{O} the set of orbits of S under the action of G . Two subsets of \mathcal{O} will play a special role. First, the set \mathcal{O}_{fin} consisting of finite orbits. Then, the subset $\mathcal{S} \subset \mathcal{O}_{\text{fin}}$ formed by the orbits $X \in \mathcal{O}_{\text{fin}}$ such that W_X is finite. For $X \in \mathcal{S}$ we denote by u_X the longest element of W_X (see Proposition 2.4) and, for $X, Y \in \mathcal{S}$, we denote by $\widehat{m}_{X,Y}$ the order of $u_X u_Y$. Note that $\widehat{M} = (\widehat{m}_{X,Y})_{X,Y \in \mathcal{S}}$ is a Coxeter matrix. Its Coxeter graph is denoted by $\widehat{\Gamma} = \widehat{\Gamma}^G$. Finally, we denote by W^G the subgroup of W of fixed elements under the action of G .

Theorem 2.5 (Hée [14], Mühlherr [24]). *Let Γ be a Coxeter graph, let G be a group of symmetries of Γ , and let (W, S) be the Coxeter system associated with Γ . Then W^G is generated by $S_W = \{u_X \mid X \in \mathcal{S}\}$ and (W^G, S_W) is a Coxeter system associated with $\widehat{\Gamma}$.*

Take a root basis $\mathbb{B} = (S, V, \Pi, \mathcal{R})$ such that $W = W(\mathbb{B})$. The action of G on S induces an action of G on V defined by $g(\alpha_s) = \alpha_{g(s)}$ for all $s \in S$ and $g \in G$. We say that \mathbb{B} is *symmetric* with respect to G if $\sigma_{g(s)} = g \sigma_s g^{-1}$ for all $s \in S$ and $g \in G$. Note that the canonical root basis is symmetric whatever is G . Suppose that \mathbb{B} is symmetric with respect to G . Then the linear representation $f : W \rightarrow \text{GL}(V)$ associated with \mathbb{B} is equivariant in the sense that $f(g(w)) = g f(w) g^{-1}$ for all $w \in W$ and $g \in G$. So, it induces a linear representation $f^G : W^G \rightarrow \text{GL}(V^G)$, where $V^G = \{x \in V \mid g(x) = x \text{ for all } g \in G\}$.

For each $X \in \mathcal{S}$ we set $\widehat{\alpha}_X = \sum_{s \in X} \alpha_s$ and we denote by \widehat{V} the vector subspace of V spanned by $\widehat{\Pi} = \{\widehat{\alpha}_X \mid X \in \mathcal{S}\}$. We have $\widehat{V} \subset V^G$ but we have no equality in general. However, we have $f^G(w)(\widehat{V}) = \widehat{V}$ for all $w \in W^G$. We set $\widehat{\sigma}_X = f^G(u_X)|_{\widehat{V}}$ for all $X \in \mathcal{S}$ and $\widehat{\mathcal{R}} = \{\widehat{\sigma}_X \mid X \in \mathcal{S}\}$.

Theorem 2.6 (Hée [14]). *The quadruple $\widehat{\mathbb{B}} = (S, \widehat{V}, \widehat{\Pi}, \widehat{\mathcal{R}})$ is a root basis which is reduced if \mathbb{B} is reduced. Moreover, we have $W(\widehat{\mathbb{B}}) = W^G$.*

The root basis $\widehat{\mathbb{B}}$ of Theorem 2.6 will be called the *equivariant root basis* of \mathbb{B}/G .

3. Definition of $\widehat{\mathcal{B}}$

From now on Γ denotes a given Coxeter graph, $M = (m_{s,t})_{s,t \in S}$ denotes its Coxeter matrix, and (W, S) denotes its Coxeter system. We take a group G of symmetries of Γ and a reduced root basis $\mathbb{B} = (S, V, \Pi, \mathcal{R})$ such that $W = W(\mathbb{B})$. We assume that \mathbb{B} is symmetric with respect to G and we use again the notations of Subsection 2.2 ($\widehat{\Gamma}, \widehat{M} = (\widehat{m}_{X,Y})_{X,Y \in S}, W^G, \widehat{\mathbb{B}} = (S, \widehat{V}, \widehat{\Pi}, \widehat{\mathcal{R}})$, and so on). We set $\Phi = \Phi(\mathbb{B})$ and $\widehat{\Phi} = \Phi(\widehat{\mathbb{B}})$.

Let \mathbb{K} be a field. We denote by E the vector space over \mathbb{K} having a basis $\mathcal{B} = \{e_\alpha \mid \alpha \in \Phi^+\}$ in one-to-one correspondence with the set Φ^+ of positive roots. The group G acts on E via its action on Φ^+ and we denote by E^G the vector subspace of E of fixed vectors under this action. We denote by Ω the set of orbits and by Ω_{fin} the set of finite orbits of Φ^+ under the action of G . For each $\omega \in \Omega_{\text{fin}}$ we set $\widehat{e}_\omega = \sum_{\alpha \in \omega} e_\alpha$. It is easily shown that $\mathcal{B}_0 = \{\widehat{e}_\omega \mid \omega \in \Omega_{\text{fin}}\}$ is a basis of E^G .

The definition of $\widehat{\mathcal{B}}$ requires the following two lemmas. The proof of the first one is left to the reader.

Lemma 3.1. *Set $V^+ = \sum_{s \in S} \mathbb{R}_+ \alpha_s$. Let $x, y \in V^+$ and $s \in S$. If $x + y \in \mathbb{R}_+ \alpha_s$, then $x, y \in \mathbb{R}_+ \alpha_s$.*

For $X \in \mathcal{S}$ we set $\omega_X = \{\alpha_s \mid s \in X\}$. Note that $\omega_X \in \Omega_{\text{fin}}$ for all $X \in \mathcal{S}$. More generally, we have $w(\omega_X) \in \Omega_{\text{fin}}$ for all $X \in \mathcal{S}$ and all $w \in W^G$.

Lemma 3.2. *Let $X, X' \in \mathcal{S}$ and $w, w' \in W^G$. If $w(\widehat{\alpha}_X) = w'(\widehat{\alpha}_{X'})$, then $w(\omega_X) = w'(\omega_{X'})$.*

Proof. Up to replacing the pair (w, w') by $(w'^{-1}w, 1)$ we can assume that $w' = 1$. Then we have $w(\widehat{\alpha}_X) = \widehat{\alpha}_{X'}$ and we must show that $w(\omega_X) = \omega_{X'}$. For that it suffices to show that the intersection of the two orbits $w(\omega_X)$ and $\omega_{X'}$ is non-empty. Either all the roots $w(\alpha_s)$, $s \in X$, lie in Φ^+ , or all of them lie in Φ^- . Moreover, their sum $w(\widehat{\alpha}_X) = \widehat{\alpha}_{X'}$ lies in $V_{X'}^+$. So, they all lie in $\Phi_{X'}^+$. Similarly, since $w^{-1}(\widehat{\alpha}_{X'}) = \widehat{\alpha}_X$, all the roots $w^{-1}(\alpha_t)$, $t \in X'$, lie in Φ_X^+ . Let $s \in X$. We have $w(\alpha_s) = \sum_{t \in X'} \lambda_t \alpha_t$ with $\lambda_t \geq 0$ for all $t \in X'$. Hence, we have $\alpha_s = \sum_{t \in X'} \lambda_t w^{-1}(\alpha_t)$ and all the vectors $\lambda_t w^{-1}(\alpha_t)$, $t \in X'$, lie in V^+ . By Lemma 3.1 it follows that all these vectors lie in $\mathbb{R}_+ \alpha_s$. But the family $\{w^{-1}(\alpha_t) \mid t \in X'\}$ is linearly independent, hence only one λ_t is nonzero. Thus, there exists $t \in X'$ such that $\lambda_t > 0$ and $w(\alpha_s) = \lambda_t \alpha_t$. Since the root basis \mathbb{B} is reduced, we have $\lambda_t = 1$, hence $w(\alpha_s) = \alpha_t \in w(\omega_X) \cap \omega_{X'}$, which completes the proof. \square

Now we can define a map $F = F_{\mathbb{B}, G} : \widehat{\Phi}^+ \rightarrow \Omega_{\text{fin}}$ as follows. Let $\widehat{\alpha} \in \widehat{\Phi}^+$. Let $X \in \mathcal{S}$ and $w \in W^G$ such that $\widehat{\alpha} = w(\widehat{\alpha}_X)$. Then we set $F(\widehat{\alpha}) = w(\omega_X)$. By Lemma 3.2 the definition of this map does not depend on the choices of w and X . Moreover, it is easily shown that it is injective. Now, we set

$$\widehat{\mathcal{B}} = \{\widehat{e}_{F(\widehat{\alpha})} \mid \widehat{\alpha} \in \widehat{\Phi}^+\},$$

and we say that the pair (Γ, G) has the $\widehat{\Phi}^+$ -basis property if $\widehat{\mathcal{B}}$ is a basis of E^G . Note that (Γ, G) has the $\widehat{\Phi}^+$ -basis property if and only if $\widehat{\mathcal{B}} = \mathcal{B}_0$. Equivalently, (Γ, G) has the $\widehat{\Phi}^+$ -basis property if and only if F is a bijection (or a surjection).

4. Proofs

4.1. Proof of Theorem 1.1

In this subsection we denote by S_{fin} the union of the finite orbits of S under the action of G , and we set $\Gamma_{\text{fin}} = \Gamma_{S_{\text{fin}}}$, $V_{\text{fin}} = V_{S_{\text{fin}}}$, $\Pi_{\text{fin}} = \Pi_{S_{\text{fin}}}$ and $\mathcal{R}_{\text{fin}} = \mathcal{R}_{S_{\text{fin}}}$. We consider the root basis $\mathbb{B}_{\text{fin}} = \mathbb{B}_{S_{\text{fin}}} = (S_{\text{fin}}, V_{\text{fin}}, \Pi_{\text{fin}}, \mathcal{R}_{\text{fin}})$ and its root system $\Phi_{\text{fin}} = \Phi_{S_{\text{fin}}} = \Phi(\mathbb{B}_{\text{fin}})$. Each symmetry $g \in G$ induces a symmetry of Γ_{fin} . We denote by G_{fin} the subgroup of $\text{Sym}(\Gamma_{\text{fin}})$ of all these symmetries.

Lemma 4.1. *Let $\alpha \in \Phi$. The following assertions are equivalent.*

- (1) *The orbit $\omega(\alpha)$ of α under the action of G is finite.*
- (2) *The root α lies in Φ_{fin} .*

Proof. Suppose that the orbit $\omega(\alpha)$ is finite. The *support* of a vector $x = \sum_{s \in S} \lambda_s \alpha_s \in V$ is defined to be $\text{Supp}(x) = \{s \in S \mid \lambda_s \neq 0\}$. The union X_α of the supports of the roots $\beta \in \omega(\alpha)$ is a finite set and is stable under the action of G , hence X_α is a union of finite orbits. This implies that $X_\alpha \subset S_{\text{fin}}$, hence $\alpha \in \Phi \cap V_{\text{fin}}$, and therefore, by Proposition 2.3, $\alpha \in \Phi_{\text{fin}}$.

Suppose $\alpha \in \Phi_{\text{fin}}$. There exist $t_1, t_2, \dots, t_n, s \in S_{\text{fin}}$ such that $\alpha = (t_1 t_2 \cdots t_n)(\alpha_s)$. For each $g \in G$ we have $g(\alpha) = (g(t_1) g(t_2) \cdots g(t_n))(\alpha_{g(s)})$. The respective orbits of t_1, t_2, \dots, t_n and s are finite, hence the orbit $\omega(\alpha) = \{g(\alpha) \mid g \in G\}$ is finite. \square

Proof of Theorem 1.1. We denote by Ω' the set of orbits of Φ_{fin}^+ under the action of G_{fin} . On the other hand we denote by $\widehat{\mathbb{B}}_{\text{fin}}$ the equivariant root basis of $\mathbb{B}_{\text{fin}}/G_{\text{fin}}$. By Lemma 4.1 each orbit of Φ_{fin}^+ under the action of G_{fin} is finite and each finite orbit in Φ^+ is contained in Φ_{fin}^+ , hence $\Omega' = \Omega_{\text{fin}}$. Moreover, since each element $X \in \mathcal{S}$ is contained in S_{fin} and W^G is generated by $\mathcal{S}_W = \{u_X \mid X \in \mathcal{S}\}$ (see Theorem 2.5), we have $(W_{S_{\text{fin}}})^{G_{\text{fin}}} = W^G$ and $\widehat{\mathbb{B}}_{\text{fin}} = \widehat{\mathbb{B}}$. So, we have $\Phi(\widehat{\mathbb{B}}_{\text{fin}})^+ = \Phi(\widehat{\mathbb{B}})^+$ and $F_{\mathbb{B}, G} = F_{\widehat{\mathbb{B}}_{\text{fin}}, G_{\text{fin}}} : \Phi(\widehat{\mathbb{B}})^+ \rightarrow \Omega_{\text{fin}}$. Since we know that (Γ, G) has the $\widehat{\Phi}^+$ -basis property if and only if $F_{\mathbb{B}, G}$ is a bijection, (Γ, G) has the $\widehat{\Phi}^+$ -basis property if and only if $(\Gamma_{\text{fin}}, G_{\text{fin}})$ has the $\widehat{\Phi}^+$ -basis property. \square

4.2. Proof of Theorem 1.2

From now on we assume that all the orbits of S under the action of G are finite. Then, by Lemma 4.1, the orbits of Φ under the action of G are also finite.

Lemma 4.2. *We assume that for each root $\alpha \in \Phi^+$ there exist $s \in S$ and $w \in W^G$ such that $\alpha = w(\alpha_s)$. Let $s, t \in S$ and $g \in G$ such that $t = g(s) \neq s$. Then $m_{s,t} = 2$.*

Proof. Suppose instead that $m_{s,t} \geq 3$. Set $\alpha = s(\alpha_t)$. We have $\alpha = \alpha_t + \lambda\alpha_s$ where $\lambda > 0$. In particular $\alpha \in \Phi^+$. So, there exist $w \in W^G$ and $r \in S$ such that $w(\alpha) = \alpha_r$. Since $t = g(s)$, we have $\alpha_t = g(\alpha_s)$, hence $w(\alpha_t) = w(g(\alpha_s)) = g(w(\alpha_s))$. This shows that either both roots $w(\alpha_s)$ and $w(\alpha_t)$ lie in Φ^+ , or they both lie in Φ^- . Moreover, $w(\alpha) = w(\alpha_t) + \lambda w(\alpha_s) = \alpha_r$, hence the two roots $w(\alpha_s)$ and $w(\alpha_t)$ lie in Φ^+ . Thus, by Lemma 3.1, the two vectors $w(\alpha_t)$ and $\lambda w(\alpha_s)$ lie in $\mathbb{R}_+\alpha_r$, which is a contradiction since, t being different from s , these two vectors are linearly independent. \square

Proposition 4.3. *The following conditions are equivalent.*

- (1) *The pair (Γ, G) has the $\widehat{\Phi}^+$ -basis property.*
- (2) *For each root $\alpha \in \Phi^+$ there exist $w \in W^G$ and $s \in S$ such that $\alpha = w(\alpha_s)$.*
- (3) *For each root $\alpha \in \Phi$ there exist $w \in W^G$ and $s \in S$ such that $\alpha = w(\alpha_s)$.*

Proof. Suppose that (Γ, G) has the $\widehat{\Phi}^+$ -basis property. Let $\alpha \in \Phi^+$. The orbit $\omega(\alpha)$ lies in $\Omega_{\text{fin}} = \Omega$ and the map $F : \widehat{\Phi}^+ \rightarrow \Omega_{\text{fin}}$ is a bijection, hence there exist $w \in W^G$ and $X \in \mathcal{S}$ such that $w(\omega_X) = \omega(\alpha)$. In particular, there exists an element $s \in X \subset S$ such that $w(\alpha_s) = \alpha$.

Suppose that for each $\alpha \in \Phi^+$ there exist $w \in W^G$ and $s \in S$ such that $\alpha = w(\alpha_s)$. Let $\omega \in \Omega_{\text{fin}} = \Omega$. Let $\alpha \in \omega$. By assumption there exist $w \in W^G$ and $s \in S$ such that $\alpha = w(\alpha_s)$. Let X be the orbit of s under the action of G . The set X is finite since it is an orbit and, by Lemma 4.2, W_X is the direct product of $|X|$ copies of $\mathbb{Z}/2\mathbb{Z}$. So, W_X is finite and $X \in \mathcal{S}$. Set $\widehat{\beta} = w(\widehat{\alpha}_X)$. We have $\widehat{\beta} \in \widehat{\Phi}^+$ and the orbit $F(\widehat{\beta}) = w(\omega_X)$ contains the root $\alpha = w(\alpha_s)$, hence it is equal to ω . So, the map F is a surjection, hence (Γ, G) has the $\widehat{\Phi}^+$ -basis property.

Suppose that for each $\alpha \in \Phi^+$ there exist $w \in W^G$ and $s \in S$ such that $\alpha = w(\alpha_s)$. In order to show that for each $\alpha \in \Phi$ there exist $w \in W^G$ and $s \in S$ such that $\alpha = w(\alpha_s)$, it suffices to consider a root $\alpha \in \Phi^-$. By assumption, since $-\alpha \in \Phi^+$, there exist $w' \in W^G$ and $s \in S$ such that $-\alpha = w'(\alpha_s)$. Let X be the orbit of s . By Lemma 4.2 the Coxeter graph Γ_X is a finite union of isolated vertices, hence W_X is finite, $u_X = \prod_{t \in X} t$, and $u_X(\alpha_t) = -\alpha_t$ for all $t \in X$. Set $w = w'u_X$. Then $w \in W^G$ and $w(\alpha_s) = w'u_X(\alpha_s) = w'(-\alpha_s) = \alpha$.

The implication (3) \Rightarrow (2) is obvious. \square

By combining Lemma 4.2 and Proposition 4.3 we get the following.

Lemma 4.4. *Suppose that (Γ, G) has the $\widehat{\Phi}^+$ -basis property. Let X be an orbit of S under the action of G . Then Γ_X is a finite union of isolated vertices. In particular, $X \in \mathcal{S}$, $u_X = \prod_{t \in X} t$, and $u_X(\alpha_t) = -\alpha_t$ for all $t \in X$.*

Proof of Theorem 1.2. Let $\Gamma_i, i \in I$, be the connected components of Γ . For $i \in I$ we denote by S_i the set of vertices of Γ_i , and we set $V_i = V_{S_i}$, $\Pi_i = \Pi_{S_i}$, and $\mathcal{R}_i = \mathcal{R}_{S_i}$. Consider the root basis $\mathbb{B}_i = \mathbb{B}_{S_i} = (S_i, V_i, \Pi_i, \mathcal{R}_i)$ and its root system $\Phi_i = \Phi_{S_i} = \Phi(\mathbb{B}_i)$. Note that Φ is the disjoint union of the Φ_i 's and W is the direct sum of the W_{S_i} 's. Recall that each symmetry $g \in \text{Stab}_G(\Gamma_i)$ induces a symmetry of Γ_i and that G_i denotes the subgroup of $\text{Sym}(\Gamma_i)$ of these symmetries.

Suppose that (Γ, G) has the $\widehat{\Phi}^+$ -basis property. Let $i \in I$. Let $\alpha \in \Phi_i$. By Proposition 4.3 there exist $s \in S$ and $w \in W^G$ such that $\alpha = w(\alpha_s)$. Since W is the direct sum of the W_{S_j} 's, w is uniquely written $w = \prod_{j \in I} w_j$, where $w_j \in W_{S_j}$ for all $j \in I$, and there are only finitely many $j \in I$ such that $w_j \neq 1$. Let $j \in I$ such that $s \in S_j$. We have $\alpha = w(\alpha_s) = w_j(\alpha_s) \in \Phi_j$, hence $i = j$ and $s \in S_i$. On the other hand, if $g \in \text{Stab}_G(\Gamma_i)$, then $g(w) = w$ and $g(W_{S_i}) = W_{S_i}$, hence $g(w_i) = w_i$. So, $w_i \in W_{S_i}^{G_i}$ and $\alpha = w_i(\alpha_s)$. By Proposition 4.3 we conclude that (Γ_i, G_i) has the $\widehat{\Phi}^+$ -basis property.

Suppose that (Γ_i, G_i) has the $\widehat{\Phi}^+$ -basis property for all $i \in I$. Let $\alpha \in \Phi$. Let $i \in I$ such that $\alpha \in \Phi_i$. By Proposition 4.3 there exist $w_i \in W_{S_i}^{G_i}$ and $s \in S_i$ such that $\alpha = w_i(\alpha_s)$. The action of G on S induces an action of G on I defined by $g(\Gamma_i) = \Gamma_{g(i)}$, for $g \in G$ and $i \in I$. Since the orbits of S under the action of G are finite, the orbits of I under the action of G are also finite. Let $J \subset I$ be the orbit of i . For each $j \in J$ we choose $g \in G$ such that $g(i) = j$ and we set $w_j = g(w_i) \in W_{S_j}$. The fact that $w_i \in W_{S_i}^{G_i}$ implies that the definition of w_j does not depend on the choice of g . Let $w = \prod_{j \in J} w_j$. Then $w \in W^G$ and $w(\alpha_s) = w_i(\alpha_s) = \alpha$. By Proposition 4.3 we conclude that (Γ, G) has the $\widehat{\Phi}^+$ -basis property. \square

4.3. Proof of Proposition 1.4

From now on we assume that Γ is connected, that G is nontrivial, and that all the orbits of S under the action of G are finite. We also assume that \mathbb{B} is the canonical root basis, $\langle \cdot, \cdot \rangle : V \times V \rightarrow \mathbb{R}$ is the canonical bilinear form of Γ , as they are defined in Subsection 2.1, and that $\Phi = \Phi(\mathbb{B})$ is the so-called *canonical root system*.

Recall that for all $s, t \in S$ we have $\langle \alpha_s, \alpha_t \rangle = -2 \cos(\pi/m_{s,t})$. In particular $\langle \alpha_s, \alpha_t \rangle = 2$ if $s = t$, $\langle \alpha_s, \alpha_t \rangle = 0$ if $m_{s,t} = 2$, $\langle \alpha_s, \alpha_t \rangle = -1$ if $m_{s,t} = 3$, and $-2 \leq \langle \alpha_s, \alpha_t \rangle < -1$ if $4 \leq m_{s,t} \leq \infty$. Let \equiv denote the equivalence relation on Φ generated by the relation \equiv_1

defined by: $\alpha \equiv_1 \beta \Leftrightarrow \langle \alpha, \beta \rangle \notin \{0, 1, -1\}$. Note that the relation \equiv_1 is reflexive (since $\langle \alpha, \alpha \rangle = 2$ for all $\alpha \in \Phi$) and symmetric.

The proof of Proposition 1.4 is divided into two parts. In a first part (see Corollary 4.13) we prove that, if \equiv has at least two equivalence classes, then Γ is one of the Coxeter graphs A_m ($m \geq 1$), D_m ($m \geq 4$), E_m ($6 \leq m \leq 8$), \tilde{A}_m ($m \geq 2$), \tilde{D}_m ($m \geq 4$), \tilde{E}_m ($6 \leq m \leq 8$), A_∞ , ${}_\infty A_\infty$, D_∞ . In a second part (see Proposition 4.17) we prove that, if (Γ, G) has the $\tilde{\Phi}^+$ -basis property, then \equiv has at least two equivalence classes.

For $\alpha \in \Phi$ we denote by $r_\alpha : V \rightarrow V$ the linear reflection defined by $r_\alpha(x) = x - \langle \alpha, x \rangle \alpha$. Note that, if $s \in S$ and $w \in W$ are such that $\alpha = w(\alpha_s)$, then $r_\alpha = w s w^{-1}$. In particular $r_\alpha \in W$ for all $\alpha \in \Phi$ and $r_{\alpha_s} = s$ for all $s \in S$.

Lemma 4.5.

- (1) We have $\alpha \equiv_1 -\alpha$ for all $\alpha \in \Phi$.
- (2) Let $\alpha, \beta \in \Phi$ such that $\alpha \equiv \beta$. Then $w(\alpha) \equiv w(\beta)$ for all $w \in W$.
- (3) Let $\alpha, \beta \in \Phi$ such that $\alpha \equiv \beta$. Then $\alpha \equiv r_\alpha(\beta)$ and $\beta \equiv r_\alpha(\beta)$.

Proof. Part (1) is true since $\langle \alpha, -\alpha \rangle = -2 \notin \{0, 1, -1\}$. Part (2) follows from the fact that each $w \in W$ preserves the bilinear form $\langle \cdot, \cdot \rangle$. Let $\alpha, \beta \in \Phi$ such that $\alpha \equiv \beta$. By Part (2) we have $r_\alpha(\alpha) \equiv r_\alpha(\beta)$. But $r_\alpha(\alpha) = -\alpha$ hence, by Part (1), $\alpha \equiv r_\alpha(\beta)$. We also have $\beta \equiv r_\alpha(\beta)$ since $\alpha \equiv \beta$. □

Lemma 4.6. Assume that $\alpha_s \equiv \alpha_t$ for all $s, t \in S$. Then all the elements of Φ are equivalent modulo the relation \equiv .

Proof. It suffices to prove that for each $\alpha \in \Phi$ there exists $s \in S$ such that $\alpha \equiv \alpha_s$. Let $\alpha \in \Phi$. There exist $t \in S$ and $w \in W$ such that $\alpha = w(\alpha_t)$. We argue by induction on the length of w . We can assume that $w \neq 1$. Then we have $w = s w'$ with $s \in S$, $w' \in W$ and $\text{lg}(w') < \text{lg}(w)$. Set $\beta = w'(\alpha_t)$. By induction there exists $u \in S$ such that $\beta \equiv \alpha_u$. We have $\alpha = w(\alpha_t) = (s w')(\alpha_t) = s(\beta)$ hence, by Lemma 4.5(2), $\alpha \equiv s(\alpha_u)$. But, by assumption, $\alpha_u \equiv \alpha_s$, hence, by Lemma 4.5(3), $\alpha_s \equiv s(\alpha_u) \equiv \alpha$. □

Recall that the *support* of a vector $x = \sum_{s \in S} \lambda_s \alpha_s \in V$ is $\text{Supp}(x) = \{s \in S \mid \lambda_s \neq 0\}$. Let $s, t \in S$. A *path* from s to t of *length* ℓ is a sequence s_0, s_1, \dots, s_ℓ in S of length $\ell + 1$ such that $s_0 = s$, $s_\ell = t$ and $m_{s_{i-1}, s_i} \geq 3$ for all $i \in \{1, \dots, \ell\}$. The *distance* between s and t , denoted by $d(s, t)$, is the shortest length of a path from s to t . Then the *distance* between an element $s \in S$ and a subset $X \subset S$ is $d(s, X) = \min\{d(s, t) \mid t \in X\}$.

Lemma 4.7. Let $\alpha = \sum_{s \in S} \lambda_s \alpha_s \in \Phi^+$, $t \in S \setminus \text{Supp}(\alpha)$ and $t_0 \in \text{Supp}(\alpha)$. Assume that $d(t, \text{Supp}(\alpha)) = d(t, t_0)$ and $\lambda_{t_0} > 1$. Then $\alpha \equiv \alpha_t$.

Proof. We argue by induction on $d = d(t, \text{Supp}(\alpha))$. There exists a path t_0, t_1, \dots, t_d of length d from t_0 to t . We first show that $\alpha \equiv_1 \alpha_{t_1}$. We have $\langle \alpha, \alpha_{t_1} \rangle = \sum_{s \in S} \lambda_s \langle \alpha_s, \alpha_{t_1} \rangle$. For each $s \in \text{Supp}(\alpha)$ we have $\lambda_s > 0$ and $\langle \alpha_s, \alpha_{t_1} \rangle \leq 0$ (since $s \neq t_1$), hence $\langle \alpha, \alpha_{t_1} \rangle \leq \lambda_{t_0} \langle \alpha_{t_0}, \alpha_{t_1} \rangle$. Moreover, we have $\lambda_{t_0} > 1$ and $\langle \alpha_{t_0}, \alpha_{t_1} \rangle \leq -1$ (since $m_{t_0, t_1} \geq 3$), hence $\langle \alpha, \alpha_{t_1} \rangle < -1$, and therefore $\alpha \equiv_1 \alpha_{t_1}$. By Lemma 4.5(3) we also have $\alpha \equiv \alpha'$, where $\alpha' = t_1(\alpha)$.

Now we can assume that $d \geq 2$. We write $\alpha' = \sum_{s \in S} \lambda'_s \alpha_s$. We have $\alpha' = \alpha - \langle \alpha, \alpha_{t_1} \rangle \alpha_{t_1}$, hence $\text{Supp}(\alpha') = \text{Supp}(\alpha) \cup \{t_1\}$, $\lambda'_{t_1} = -\langle \alpha, \alpha_{t_1} \rangle > 1$, and $d(t, \text{Supp}(\alpha')) = d(t, t_1) = d - 1$, therefore, by induction, $\alpha' \equiv \alpha_t$. Finally, we have $\alpha \equiv \alpha'$ and $\alpha' \equiv \alpha_t$, hence $\alpha \equiv \alpha_t$. \square

Lemma 4.8. *Assume that there are $s, t \in S$ such that $m_{s,t} \geq 4$. Then the relation \equiv has only one equivalence class.*

Proof. We have $\langle \alpha_s, \alpha_t \rangle = -2 \cos(\pi/m_{s,t}) \leq -2 \cos(\pi/4) = -\sqrt{2} < -1$, hence $\alpha_s \equiv \alpha_t$. By Lemma 4.5(3) we also have $\alpha_s \equiv \alpha$ where $\alpha = s(\alpha_t)$. Let $u \in S \setminus \{s, t\}$. By Lemma 4.6 it suffices to show that either $\alpha_u \equiv \alpha_s$ or $\alpha_u \equiv \alpha_t$. We can and do assume that $d(u, s) \leq d(u, t)$ and we show that $\alpha_u \equiv \alpha_s$. Set $\alpha = \lambda_s \alpha_s + \alpha_t$. We have $\text{Supp}(\alpha) = \{s, t\}$, $d(u, \text{Supp}(\alpha)) = d(u, s)$, and $\lambda_s = -\langle \alpha_s, \alpha_t \rangle > 1$, hence, by Lemma 4.7, $\alpha_u \equiv \alpha$. So, since $\alpha_s \equiv \alpha$, we have $\alpha_u \equiv \alpha_s$. \square

Lemma 4.9. *If S contains a subset Y such that*

- (1) $\emptyset \neq Y \neq S$, and
- (2) *for all $s \in Y$ there exists $\alpha = \sum_{r \in Y} \lambda_r \alpha_r \in \Phi_Y^+$ such that $\alpha \equiv \alpha_s$ and $\lambda_r > 1$ for all $r \in \text{Supp}(\alpha)$,*

then \equiv has only one equivalence class.

Proof. Let $s \in Y$ and $t \in S \setminus Y$. There exists a root $\alpha = \sum_{r \in Y} \lambda_r \alpha_r \in \Phi_Y^+$ such that $\alpha \equiv \alpha_s$ and $\lambda_r > 1$ for all $r \in \text{Supp}(\alpha)$. Then, by Lemma 4.7, $\alpha \equiv \alpha_t$. So, since $\alpha \equiv \alpha_s$, we have $\alpha_s \equiv \alpha_t$. Let $s, s' \in Y$. Since $Y \neq S$, we can take $t \in S \setminus Y$. By the above, $\alpha_s \equiv \alpha_t$ and $\alpha_{s'} \equiv \alpha_t$, hence $\alpha_s \equiv \alpha_{s'}$. Let $t, t' \in S \setminus Y$. Since $Y \neq \emptyset$, we can take $s \in Y$. By the above, $\alpha_s \equiv \alpha_t$ and $\alpha_s \equiv \alpha_{t'}$, hence $\alpha_t \equiv \alpha_{t'}$. We conclude by applying Lemma 4.6. \square

Lemma 4.10. *Suppose that Γ is one of the following Coxeter graphs of affine type: \tilde{A}_m ($m \geq 2$), \tilde{D}_m ($m \geq 4$), \tilde{E}_6 , \tilde{E}_7 , \tilde{E}_8 . For each $s \in S$ there exists a root $\alpha = \sum_{r \in S} \lambda_r \alpha_r \in \Phi^+$ such that $\langle \alpha_s, \alpha \rangle = -2$ and $\lambda_r \geq 2$ for all $r \in S$.*

Proof. We number the elements of S as in Bourbaki [2, Planches] with the convention that the unnumbered vertex in Bourbaki [2, Planches] is here labelled with 0. Let β denote the greatest root of $\Phi_{S \setminus \{0\}}$. Here is the value of β according to Γ .

- If $\Gamma = \widetilde{A}_m$ ($m \geq 2$), then $\beta = \alpha_1 + \alpha_2 + \cdots + \alpha_m$.
- If $\Gamma = \widetilde{D}_m$ ($m \geq 4$), then $\beta = \alpha_1 + 2\alpha_2 + \cdots + 2\alpha_{m-2} + \alpha_{m-1} + \alpha_m$.
- If $\Gamma = \widetilde{E}_6$, then $\beta = \alpha_1 + 2\alpha_2 + 2\alpha_3 + 3\alpha_4 + 2\alpha_5 + \alpha_6$.
- If $\Gamma = \widetilde{E}_7$, then $\beta = 2\alpha_1 + 2\alpha_2 + 3\alpha_3 + 4\alpha_4 + 3\alpha_5 + 2\alpha_6 + \alpha_7$.
- If $\Gamma = \widetilde{E}_8$, then $\beta = 2\alpha_1 + 3\alpha_2 + 4\alpha_3 + 6\alpha_4 + 5\alpha_5 + 4\alpha_6 + 3\alpha_7 + 2\alpha_8$.

We observe in each case that $\langle \alpha_0, \beta \rangle = -2$. In particular, we have $s_0(\beta) = 2\alpha_0 + \beta$. Set $\delta = \alpha_0 + \beta$. Then $\alpha_0 + \delta = s_0(\beta) \in \Phi$.

Observe that all the coordinates of δ in the basis Π are ≥ 1 . On the other hand, for each root $\alpha \in \Phi$ we have $(\alpha + \delta) \in \Phi$ and $\langle \alpha, \delta \rangle = 0$. Indeed, we see case by case that, for each $s \in S$, $\langle \alpha_s, \delta \rangle = 0$. Subsequently $\langle \alpha, \delta \rangle = 0$ for all $\alpha \in \Phi$ and $w(\delta) = \delta$ for all $w \in W$. Now, Γ is connected and simply laced, hence for each $\alpha \in \Phi$ there exists $w \in W$ such that $\alpha = w(\alpha_0)$. So, $\alpha + \delta = w(\alpha_0 + \delta) = (ws_0)(\beta) \in \Phi$.

Let $s \in S$. Since Γ is simply laced and connected there exists $w \in W$ such that $\alpha_s = w(\alpha_0)$. We set $\alpha' = w(\beta)$ and we choose $k \geq 1$ so that all the coordinates of $\alpha = \alpha' + k\delta$ in the basis Π are ≥ 2 . Then, by the above, $\alpha \in \Phi$ and $\langle \alpha_s, \alpha \rangle = \langle \alpha_s, \alpha' \rangle = \langle w(\alpha_0), w(\beta) \rangle = \langle \alpha_0, \beta \rangle = -2$. \square

Corollary 4.11. *Suppose that there is a proper subset Y of S such that Γ_Y is one of the following Coxeter graphs of affine type: \widetilde{A}_m ($m \geq 2$), \widetilde{D}_m ($m \geq 4$), \widetilde{E}_6 , \widetilde{E}_7 , \widetilde{E}_8 . Then the relation \equiv has only one equivalence class.*

Proof. This follows from Lemma 4.9 and Lemma 4.10. \square

Lemma 4.12. *Suppose that Γ is simply laced. Then one of the following three assertions is satisfied.*

- (1) Γ is one of the following Coxeter graphs of spherical type: A_m ($m \geq 1$), D_m ($m \geq 4$), E_6 , E_7 , E_8 .
- (2) Γ is one of the following locally spherical Coxeter graphs: A_∞ , ${}_\infty A_\infty$, D_∞ .
- (3) There exists a subset Y of S such that Γ_Y is one of the following Coxeter graphs of affine type: \widetilde{A}_m ($m \geq 2$), \widetilde{D}_m ($m \geq 4$), \widetilde{E}_6 , \widetilde{E}_7 , \widetilde{E}_8 .

Proof. If Γ contains a circuit, then there is a subset Y of S such that $\Gamma_Y = \widetilde{A}_m$ ($m \geq 2$). So, we can assume that Γ is a tree. If all the vertices of Γ are of valence ≤ 2 , then $\Gamma \in \{A_m \mid m \geq 1\} \cup \{A_\infty, {}_\infty A_\infty\}$. So, we can assume that Γ has at least one vertex of

valence ≥ 3 . If Γ has at least two vertices of valence ≥ 3 , then there exists a subset Y of S such that $\Gamma_Y = \widetilde{D}_m$ ($m \geq 5$). So, we can assume that Γ has a unique vertex s_0 of valence ≥ 3 . If the valence of s_0 is ≥ 4 , then there is a subset Y of S such that $\Gamma_Y = \widetilde{D}_4$. So, we can assume that the valence of s_0 is 3. We denote by ℓ_1, ℓ_2, ℓ_3 the (finite or infinite) lengths of the branches from s_0 and we assume that $1 \leq \ell_1 \leq \ell_2 \leq \ell_3 \leq \infty$. If $\ell_1 \geq 2$, then there is a subset Y of S such that $\Gamma_Y = \widetilde{E}_6$. So, we can assume that $\ell_1 = 1$. If $\ell_2 \geq 3$, then there is a subset Y of S such that $\Gamma_Y = \widetilde{E}_7$. If $\ell_2 = 1$ and $\ell_3 < \infty$, then $\Gamma = D_m$ where $m = \ell_3 + 3$. If $\ell_2 = 1$ and $\ell_3 = \infty$, then $\Gamma = D_\infty$. So, we can assume that $\ell_2 = 2$. If $\ell_3 = 2, 3, 4$, then $\Gamma = E_6, E_7, E_8$, respectively. If $\ell_3 \geq 5$, then there is a subset Y of S such that $\Gamma_Y = \widetilde{E}_8$. \square

Corollary 4.13. *If the relation \equiv has at least two equivalence classes, then Γ is one of the following Coxeter graphs: A_m ($m \geq 1$), D_m ($m \geq 4$), E_m ($6 \leq m \leq 8$), \widetilde{A}_m ($m \geq 2$), \widetilde{D}_m ($m \geq 4$), \widetilde{E}_m ($6 \leq m \leq 8$), $A_\infty, {}_\infty A_\infty, D_\infty$.*

Proof. This follows from Lemma 4.8, Corollary 4.11 and Lemma 4.12. \square

Now we start the second part of the proof of Proposition 1.4.

Lemma 4.14. *Assume that (Γ, G) has the $\widehat{\Phi}^+$ -basis property. Let $\alpha, \beta \in \Phi$ and $g \in G$ such that $\beta = g(\alpha) \neq \alpha$. Then $\langle \alpha, \beta \rangle = 0$.*

Proof. By Proposition 4.3 there exist $w \in W^G$ and $s \in S$ such that $\alpha = w(\alpha_s)$. Set $t = g(s)$. We have $\alpha_t = g(\alpha_s)$, hence $\beta = g(\alpha) = g(w(\alpha_s)) = w(g(\alpha_s)) = w(\alpha_t)$. Since $\beta \neq \alpha$, we have $\alpha_t \neq \alpha_s$, thus $t \neq s$. By Lemma 4.4 we have $m_{s,t} = 2$, hence $\langle \alpha_s, \alpha_t \rangle = 0$, and therefore $\langle \alpha, \beta \rangle = \langle w(\alpha_s), w(\alpha_t) \rangle = \langle \alpha_s, \alpha_t \rangle = 0$. \square

Lemma 4.15. *Suppose that (Γ, G) has the $\widehat{\Phi}^+$ -basis property. Let $\alpha, \beta \in \Phi$ and $g \in G$ such that $g(\alpha) = \alpha$ and $\langle \alpha, \beta \rangle \notin \{0, 1, -1\}$. Then $g(\beta) = \beta$.*

Proof. Set $\gamma = r_\beta(\alpha)$. We have $\gamma = \alpha - \langle \alpha, \beta \rangle \beta$, hence $g(\gamma) = g(\alpha) - \langle \alpha, \beta \rangle g(\beta) = \alpha - \langle \alpha, \beta \rangle g(\beta)$, and therefore

$$\begin{aligned} \langle \gamma, g(\gamma) \rangle &= \langle \alpha - \langle \alpha, \beta \rangle \beta, \alpha - \langle \alpha, \beta \rangle g(\beta) \rangle \\ &= \langle \alpha, \alpha \rangle - \langle \alpha, \beta \rangle \langle \beta, \alpha \rangle - \langle \alpha, \beta \rangle \langle \alpha, g(\beta) \rangle + \langle \alpha, \beta \rangle^2 \langle \beta, g(\beta) \rangle \\ &= 2 - 2\langle \alpha, \beta \rangle^2 + \langle \alpha, \beta \rangle^2 \langle \beta, g(\beta) \rangle, \end{aligned}$$

since $\langle \alpha, \alpha \rangle = 2$ and $\langle \alpha, g(\beta) \rangle = \langle g(\alpha), g(\beta) \rangle = \langle \alpha, \beta \rangle$. Suppose that $g(\beta) \neq \beta$. Then, since $\langle \alpha, \beta \rangle \neq 0$, we also have $g(\gamma) \neq \gamma$. Then, by Lemma 4.14, we get $\langle \beta, g(\beta) \rangle = 0$ and $\langle \gamma, g(\gamma) \rangle = 0$. It follows that $2 - 2\langle \alpha, \beta \rangle^2 = 0$, hence $\langle \alpha, \beta \rangle^2 = 1$, which is a contradiction as $\langle \alpha, \beta \rangle \notin \{1, -1\}$. So, $g(\beta) = \beta$. \square

Lemma 4.16. *Suppose that (Γ, G) has the $\widehat{\Phi}^+$ -basis property. Let $g \in G$. Then there exists $s \in S$ such that $g(s) = s$.*

Proof. Suppose instead that $g(s) \neq s$ for all $s \in S$. Take an element s in S such that the distance $\ell = d(s, g(s))$ is minimal. By Lemma 4.4 we have $\ell \geq 2$. Let $s = s_0, s_1, \dots, s_\ell = g(s)$ be a path of length ℓ from s to $g(s)$. The minimality of ℓ implies that the sets $\{s_0, s_1, \dots, s_{\ell-1}\}$ and $\{s_\ell = g(s_0), g(s_1), \dots, g(s_{\ell-1})\}$ are disjoint. Set $\alpha = (s_0 s_1 \cdots s_{\ell-2})(\alpha_{s_{\ell-1}})$ and $\beta = g(\alpha)$. We have $\alpha = \lambda_0 \alpha_{s_0} + \lambda_1 \alpha_{s_1} + \cdots + \lambda_{\ell-2} \alpha_{s_{\ell-2}} + \alpha_{s_{\ell-1}}$ where $\lambda_i > 0$ for all $i \in \{1, \dots, \ell-2\}$. Thus $\beta = g(\alpha) = \lambda_0 \alpha_{g(s_0)} + \lambda_1 \alpha_{g(s_1)} + \cdots + \lambda_{\ell-2} \alpha_{g(s_{\ell-2})} + \alpha_{g(s_{\ell-1})}$. In particular, $\beta \neq \alpha$. However, since $\text{Supp}(\alpha) \cap \text{Supp}(\beta) = \emptyset$, $s_{\ell-1} \in \text{Supp}(\alpha)$, $s_\ell = g(s_0) \in \text{Supp}(\beta)$, and $m_{s_{\ell-1}, s_\ell} \geq 3$, we have $\langle \alpha, \beta \rangle < 0$. This contradicts Lemma 4.14. \square

Proposition 4.17. *Suppose that (Γ, G) has the $\widehat{\Phi}^+$ -basis property. Then the relation \equiv has at least two equivalence classes.*

Proof. Suppose instead that \equiv has a unique equivalence class. Let $g \in G$. Set $U = \{x \in V \mid g(x) = x\}$. By Lemma 4.16 there exists $s \in S$ such that $g(s) = s$. Then $g(\alpha_s) = \alpha_s$. Let $\beta \in \Phi$. By assumption we have $\alpha_s \equiv \beta$. It follows from Lemma 4.15 that $g(\beta) = \beta$. Thus, U contains Φ , hence $U = V$. So, $G = \{\text{id}\}$ which is a contradiction since we are under the assumption $G \neq \{\text{id}\}$. So, \equiv has at least two equivalence classes. \square

Proof of Proposition 1.4. Suppose that (Γ, G) has the $\widehat{\Phi}^+$ -basis property. By Proposition 4.17 the relation \equiv has at least two equivalence classes, hence, by Corollary 4.13, Γ is one of the following Coxeter graphs: A_m ($m \geq 1$), D_m ($m \geq 4$), E_m ($6 \leq m \leq 8$), \widetilde{A}_m ($m \geq 2$), \widetilde{D}_m ($m \geq 4$), \widetilde{E}_m ($6 \leq m \leq 8$), $A_\infty, {}_\infty A_\infty, D_\infty$. The Coxeter graphs $A_1, E_7, E_8, \widetilde{E}_8$ and A_∞ have no nontrivial symmetry, hence Γ is not one of these graphs. The Coxeter graph A_{2m} has no nontrivial symmetry fixing an element of S and we know by Lemma 4.16 that each element of G fixes at least one element of S , hence neither Γ is A_{2m} . If g is a nontrivial symmetry of the Coxeter graph \widetilde{A}_{2m} that fixes an element of S , then there exist $s, t \in S$ such that $m_{s,t} = 3$ and $g(s) = t$, hence, by Lemma 4.2, such an element cannot lie in G . Thus, Γ is also different from \widetilde{A}_{2m} . So, Γ is one of the following Coxeter graphs: A_{2m+1} ($m \geq 1$), D_m ($m \geq 4$), $E_6, \widetilde{A}_{2m+1}$ ($m \geq 1$), \widetilde{D}_m ($m \geq 4$), $\widetilde{E}_6, \widetilde{E}_7, {}_\infty A_\infty, D_\infty$. \square

4.4. Proof of Theorem 1.3

We assume again that Γ is connected, that G is non-trivial, and that the orbits of S under the action of G are finite. We also assume that Φ is the canonical root system of Γ and that $\langle \cdot, \cdot \rangle : V \times V \rightarrow \mathbb{R}$ is its canonical bilinear form.

Lemma 4.18. *Assume that (Γ, G) has the $\widehat{\Phi}^+$ -basis property. Then (Γ, G) is up to isomorphism one of the pairs given in the statement of Theorem 1.3.*

Proof. By Proposition 1.4 we know that Γ is one of the following Coxeter graphs: A_{2m+1} ($m \geq 1$), D_m ($m \geq 4$), E_6 , \tilde{A}_{2m+1} ($m \geq 1$), \tilde{D}_m ($m \geq 4$), \tilde{E}_6 , \tilde{E}_7 , ${}_{\infty}A_{\infty}$, D_{∞} . By Lemma 4.16 we also know that for each $g \in G$ there exists $s \in S$ such that $g(s) = s$. If $\Gamma = \tilde{A}_{2m+1}$ and g_1, g_2 are two distinct symmetries of Γ conjugated to the symmetry described in Case (v) of Theorem 1.3, then $g = g_1 g_2$ does not fix any element of S . By Lemma 4.16 such an element cannot lie in G . Similarly, if g_1, g_2 are two distinct symmetries of ${}_{\infty}A_{\infty}$ conjugated to the symmetry described in Case (ix) of Theorem 1.3, then $g = g_1 g_2$ does not fix any element of S , hence such an element cannot lie in G . Observe that, if H is a subgroup of the symmetric group \mathfrak{S}_4 which contains no cycle of length 4 and no product of two disjoint transpositions, then H fixes an element of $\{1, 2, 3, 4\}$. Using this observation it is easily seen that, when $\Gamma = \tilde{D}_4$, we are either in Case (vi) or Case (vii) of Theorem 1.3, or in the following Case (a) or Case (c). So, it remains to prove that (Γ, G) is not one of the following pairs (see Figure 4.1).

(a) $\Gamma = \tilde{D}_m$ ($m \geq 4$) and G contains an element g of order 2 such that

$$g(s_0) = s_1, g(s_1) = s_0, g(s_i) = s_i \ (2 \leq i \leq m-2), g(s_{m-1}) = s_m, g(s_m) = s_{m-1}.$$

(b) $\Gamma = \tilde{D}_{2m}$ ($m \geq 3$) and G contains an element g of order 2 such that

$$g(s_i) = s_{2m-i} \ (0 \leq i \leq 2m).$$

(c) $\Gamma = \tilde{D}_4$ and G contains an element g of order 4 such that

$$g(s_0) = s_4, g(s_1) = s_0, g(s_2) = s_2, g(s_3) = s_1, g(s_4) = s_3.$$

(d) $\Gamma = \tilde{E}_6$ and G contains an element g of order 3 such that

$$g(s_0) = s_6, g(s_1) = s_0, g(s_2) = s_5, g(s_3) = s_2, g(s_4) = s_4, g(s_5) = s_3, g(s_6) = s_1.$$

(e) $\Gamma = \tilde{E}_7$ and G contains an element g of order 2 such that

$$\begin{aligned} g(s_0) &= s_7, g(s_1) = s_6, g(s_2) = s_2, g(s_3) = s_5, \\ g(s_4) &= s_4, g(s_5) = s_3, g(s_6) = s_1, g(s_7) = s_0. \end{aligned}$$

In each of the five cases we show a root $\alpha \in \Phi$ such that $g(\alpha) \neq \alpha$ and $\langle \alpha, g(\alpha) \rangle \neq 0$. By Lemma 4.14 this implies that (Γ, G) does not have the $\widehat{\Phi}^+$ -basis property.

(a) We take $\alpha = \alpha_1 + \alpha_2 + \cdots + \alpha_{m-2} + \alpha_{m-1}$. Then $g(\alpha) = \alpha_0 + \alpha_2 + \cdots + \alpha_{m-2} + \alpha_m \neq \alpha$ and $\langle \alpha, g(\alpha) \rangle = -2 \neq 0$.

(b) We take $\alpha = \alpha_0 + \alpha_1 + 2\alpha_2 + \cdots + 2\alpha_{m-1} + \alpha_m$. Then $g(\alpha) = \alpha_m + 2\alpha_{m+1} + \cdots + 2\alpha_{2m-2} + \alpha_{2m-1} + \alpha_{2m} \neq \alpha$ and $\langle \alpha, g(\alpha) \rangle = -2 \neq 0$.

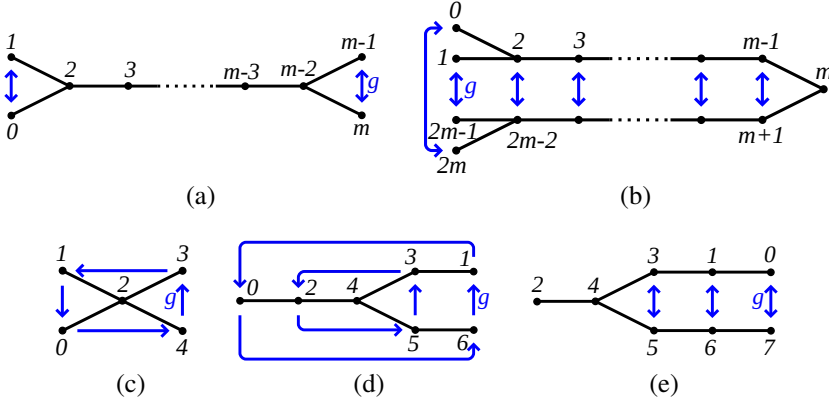

FIGURE 4.1. Pairs that do not have the $\widehat{\Phi}^+$ -basis property

- (c) We take $\alpha = \alpha_0 + \alpha_2 + \alpha_3$. Then $g(\alpha) = \alpha_1 + \alpha_2 + \alpha_4 \neq \alpha$ and $\langle \alpha, g(\alpha) \rangle = -2 \neq 0$.
- (d) We take $\alpha = \alpha_0 + \alpha_2 + \alpha_4 + \alpha_5$. Then $g(\alpha) = \alpha_3 + \alpha_4 + \alpha_5 + \alpha_6 \neq \alpha$ and $\langle \alpha, g(\alpha) \rangle = -1 \neq 0$.
- (e) We take $\alpha = \alpha_1 + \alpha_2 + \alpha_3 + 2\alpha_4 + 2\alpha_5 + \alpha_6 + \alpha_7$. Then $g(\alpha) = \alpha_0 + \alpha_1 + \alpha_2 + 2\alpha_3 + 2\alpha_4 + \alpha_5 + \alpha_6 + \alpha_7 \neq \alpha$ and $\langle \alpha, g(\alpha) \rangle = -2 \neq 0$. □

It remains to show that the pairs of Theorem 1.3 have the $\widehat{\Phi}^+$ -basis property. We start with the pairs with a Coxeter graph of spherical type, that is, the first four cases. For $\alpha \in \Phi$ we denote by $W^G \alpha$ the orbit of α under the action of W^G .

Lemma 4.19. *Suppose that (Γ, G) is one of the pairs of Theorem 1.3. Let $\alpha \in \Phi$.*

- (1) *We have $W^G(-\alpha) = -(W^G \alpha)$.*
- (2) *For each $g \in G$ we have $g(W^G \alpha) = W^G g(\alpha)$.*
- (3) *For each $s \in S$ the orbit $W^G \alpha_s$ contains $-\alpha_s$ so that $W^G \alpha_s = W^G(-\alpha_s)$.*

Proof. Let $\alpha \in \Phi$ and $w \in W^G$. Then $w(-\alpha) = -w(\alpha)$ and $g(w(\alpha)) = w(g(\alpha))$ for all $g \in G$. This shows Part (1) and Part (2). Let $s \in S$ and let X be the orbit of s under the action of G . Recall that (Γ, G) is one of the pairs of Theorem 1.3. Observe that, in each case, the Coxeter graph Γ_X is a union of isolated vertices. Thus, $u_X = \prod_{t \in X} t$ and $u_X(\alpha_t) = -\alpha_t$ for all $t \in X$. So, $u_X \in W^G$ and $u_X(\alpha_s) = -\alpha_s$, hence $W^G \alpha_s = W^G(-\alpha_s)$. □

Lemma 4.20. *If (Γ, G) is one of the pairs given in Case (i), Case (ii), Case (iii) and Case (iv) of Theorem 1.3, then (Γ, G) has the $\widehat{\Phi}^+$ -basis property.*

Proof. Note that Γ is of spherical type in all the four cases. We number again the vertices of Γ as in Bourbaki [2, Planches] (see also Figure 1.2) and we use the description of Φ^+ given in that reference. By Proposition 4.3 it suffices to show that there exists a subset $X \subset S$ such that $\Phi = \cup_{s \in X} W^G \alpha_s$. We argue case by case.

Case (i). We show that $\Phi = W^G \alpha_m \cup W^G \alpha_{m+1}$. The orbits of S under the action of G are $X_1 = \{1, 2m+1\}$, $X_2 = \{2, 2m\}$, \dots , $X_m = \{m, m+2\}$ and $\{m+1\}$. Thus, by Theorem 2.5, $W^G = \langle u_{X_1}, \dots, u_{X_m}, s_{m+1} \rangle$. By Lemma 4.19 it suffices to show that $W^G \alpha_m \cup W^G \alpha_{m+1}$ contains Φ^+ . First, we show that the orbit $W^G \alpha_{m+1}$ contains all the roots $\alpha \in \Phi^+$ such that $g(\alpha) = \alpha$. Indeed, such a root either is equal to α_{m+1} , or is of the form $\alpha = \sum_{i=k}^{2m+2-k} \alpha_i$ with $1 \leq k \leq m$. In the second case we have $\alpha = (u_{X_k} \cdots u_{X_m})(\alpha_{m+1})$. Now, we show that $W^G \alpha_m$ contains all the roots $\alpha \in \Phi^+$ such that $g(\alpha) \neq \alpha$, that is, the set of roots $\alpha = \sum_{i=1}^{2m+1} \lambda_i \alpha_i \in \Phi^+$ such that $\sum_{i=1}^m \lambda_i \neq \sum_{i=m+2}^{2m+1} \lambda_i$. For $2 \leq k \leq m$ we have $\alpha_{k-1} = (u_{X_k} u_{X_{k-1}})(\alpha_k)$. Hence $W^G \alpha_m$ contains the set $\{\alpha_k \mid 1 \leq k \leq m\}$. Now, let $1 \leq k < \ell \leq m$. Then $\alpha_m + \alpha_{m+1} = s_{m+1}(\alpha_m) \in W^G \alpha_m$,

$$\begin{aligned} \sum_{i=k}^{\ell} \alpha_i &= (u_{X_\ell} \cdots u_{X_{k+1}})(\alpha_k) \in W^G \alpha_m, \\ \sum_{i=k}^{m+1} \alpha_i &= (s_{m+1} u_{X_m} \cdots u_{X_{k+1}})(\alpha_k) \in W^G \alpha_m, \\ \sum_{i=k}^{2m+2-\ell} \alpha_i &= (u_{X_\ell} \cdots u_{X_m} s_{m+1} u_{X_m} \cdots u_{X_{k+1}})(\alpha_k) \in W^G \alpha_m. \end{aligned}$$

So, the orbit $W^G \alpha_m$ contains the set Ψ of roots $\alpha = \sum_{i=1}^{2m+1} \lambda_i \alpha_i \in \Phi^+$ such that $\sum_{i=1}^m \lambda_i > \sum_{i=m+2}^{2m+1} \lambda_i$. On the other hand, the orbit $W^G \alpha_m$ also contains the root $(s_{m+1} u_{X_m} s_{m+1})(\alpha_m) = \alpha_{m+2}$. Thus, this orbit contains α_m and $g(\alpha_m) = \alpha_{m+2}$. By Lemma 4.19(2), $W^G \alpha_m$ is stable by g , hence it contains the set $g(\Psi)$ of roots $\alpha = \sum_{i=1}^{2m+1} \lambda_i \alpha_i \in \Phi^+$ such that $\sum_{i=1}^m \lambda_i < \sum_{i=m+2}^{2m+1} \lambda_i$. This ends the proof of Case (i).

Case (ii). We show that $\Phi = W^G \alpha_{m-2} \cup W^G \alpha_m$. The orbits of S under the action of G are $\{1\}$, $\{2\}$, \dots , $\{m-2\}$ and $X = \{m-1, m\}$. Thus, by Theorem 2.5, $W^G = \langle s_1, \dots, s_{m-2}, u_X \rangle$. By Lemma 4.19 it suffices to show that $W^G \alpha_{m-2} \cup W^G \alpha_m$ contains Φ^+ . The orbit $W^G \alpha_m$ contains α_m . For $1 \leq k \leq m-2$ it contains $(s_k \cdots s_{m-2})(\alpha_m) = \sum_{i=k}^{m-2} \alpha_i + \alpha_m$. It also contains $(s_{m-2} u_X s_{m-2})(\alpha_m) = \alpha_{m-1}$ and, for each $1 \leq k \leq m-2$, the root $(s_k \cdots s_{m-2})(\alpha_{m-1}) = \sum_{i=k}^{m-2} \alpha_i + \alpha_{m-1}$. So, the orbit $W^G \alpha_m$ contains all the roots $\alpha \in \Phi^+$ such that $g(\alpha) \neq \alpha$. Now, we show that $W^G \alpha_{m-2}$ contains all the roots $\alpha \in \Phi^+$ such that

$g(\alpha) = \alpha$. For $1 \leq k \leq m-3$ we have $\alpha_k = (s_{k+1}s_k)(\alpha_{k+1})$. Thus, the orbit $W^G\alpha_{m-2}$ contains the set $\{\alpha_k \mid 1 \leq k \leq m-2\}$. It follows that it contains for each $1 \leq \ell < k \leq m-2$ the root $\sum_{i=\ell}^k \alpha_i = (s_\ell \cdots s_{k-1})(\alpha_k)$. On the other hand, $W^G\alpha_{m-2}$ contains $\alpha_{m-2} + \alpha_{m-1} + \alpha_m = u_X(\alpha_{m-2})$. So, it contains $\sum_{i=k}^m \alpha_i = (s_k \cdots s_{m-3})(\alpha_{m-2} + \alpha_{m-1} + \alpha_m)$ for each $1 \leq k \leq m-3$. It also contains for each $1 \leq k < \ell \leq m-2$ the root

$$\sum_{i=k}^{\ell-1} \alpha_i + \sum_{i=\ell}^{m-2} 2\alpha_i + \alpha_{m-1} + \alpha_m = (s_\ell \cdots s_{m-2}) \left(\sum_{i=k}^m \alpha_i \right).$$

This completes the proof of Case (ii).

Case (iii). The orbits of S under the action of G are $X = \{1, 2, 3\}$ and $\{2\}$ hence, by Theorem 2.5, $W^G = \langle u_X, s_2 \rangle$. We show that $\Phi = \cup_{i=1}^4 W^G\alpha_i$. By Lemma 4.19 it suffices to show that $\cup_{i=1}^4 W^G\alpha_i$ contains the 12 positive roots of Φ . The orbit $W^G\alpha_1$ contains $\alpha_1, s_2(\alpha_1) = \alpha_1 + \alpha_2$ and $(u_X s_2)(\alpha_1) = \alpha_2 + \alpha_3 + \alpha_4$. Similarly, the orbit $W^G\alpha_3$ contains $\alpha_3, \alpha_2 + \alpha_3$ and $\alpha_1 + \alpha_2 + \alpha_4$, and the orbit $W^G\alpha_4$ contains $\alpha_4, \alpha_2 + \alpha_4$ and $\alpha_1 + \alpha_2 + \alpha_3$. Finally, the orbit $W^G\alpha_2$ contains the roots $\alpha_2, u_X(\alpha_2) = \alpha_1 + \alpha_2 + \alpha_3 + \alpha_4$ and $(s_2 u_X)(\alpha_2) = \alpha_1 + 2\alpha_2 + \alpha_3 + \alpha_4$.

Case (iv). We show that $\Phi = W^G\alpha_3 \cup W^G\alpha_4$. The orbits of S under the action of G are $X = \{1, 6\}, Y = \{3, 5\}, \{4\}, \{2\}$. Thus, by Theorem 2.5, $W^G = \langle u_X, u_Y, s_4, s_2 \rangle$. By Lemma 4.19 it suffices to show that $W^G\alpha_3 \cup W^G\alpha_4$ contains the 36 positive roots of Φ . The orbit $W^G\alpha_4$ contains the 12 roots $\alpha \in \Phi^+$ such that $g(\alpha) = \alpha$, namely:

$$\begin{aligned} \gamma_1 &= \alpha_4, \gamma_2 = s_2(\alpha_4) = \alpha_2 + \alpha_4, \gamma_3 = s_4(\gamma_2) = \alpha_2, \gamma_4 = u_Y(\alpha_4) = \alpha_3 + \alpha_4 + \alpha_5, \\ \gamma_5 &= s_2(\gamma_4) = \alpha_2 + \alpha_3 + \alpha_4 + \alpha_5, \gamma_6 = u_X(\gamma_4) = \alpha_1 + \alpha_3 + \alpha_4 + \alpha_5 + \alpha_6, \\ \gamma_7 &= s_2(\gamma_6) = \alpha_1 + \alpha_2 + \alpha_3 + \alpha_4 + \alpha_5 + \alpha_6, \gamma_8 = s_4(\gamma_5) = \alpha_2 + \alpha_3 + 2\alpha_4 + \alpha_5, \\ \gamma_9 &= s_4(\gamma_7) = \alpha_1 + \alpha_2 + \alpha_3 + 2\alpha_4 + \alpha_5 + \alpha_6, \\ \gamma_{10} &= u_Y(\gamma_9) = \alpha_1 + \alpha_2 + 2\alpha_3 + 2\alpha_4 + 2\alpha_5 + \alpha_6, \\ \gamma_{11} &= s_4(\gamma_{10}) = \alpha_1 + \alpha_2 + 2\alpha_3 + 3\alpha_4 + 2\alpha_5 + \alpha_6, \\ \gamma_{12} &= s_2(\gamma_{11}) = \alpha_1 + 2\alpha_2 + 2\alpha_3 + 3\alpha_4 + 2\alpha_5 + \alpha_6. \end{aligned}$$

Now, we show that the orbit $W^G\alpha_3$ contains the 24 roots $\alpha \in \Phi^+$ such that $g(\alpha) \neq \alpha$. First, it contains the following 12 roots, that are the positive roots $\alpha = \sum_{i=1}^6 \lambda_i \alpha_i$ such

that $\lambda_1 + \lambda_3 > \lambda_5 + \lambda_6$.

$$\begin{aligned}\delta_1 &= \alpha_3, \delta_2 = u_X(\delta_1) = \alpha_1 + \alpha_3, \delta_3 = u_Y(\delta_2) = \alpha_1, \delta_4 = s_4(\delta_1) = \alpha_3 + \alpha_4, \\ \delta_5 &= s_4(\delta_2) = \alpha_1 + \alpha_3 + \alpha_4, \delta_6 = s_2(\delta_4) = \alpha_2 + \alpha_3 + \alpha_4, \\ \delta_7 &= s_2(\delta_5) = \alpha_1 + \alpha_2 + \alpha_3 + \alpha_4, \delta_8 = u_Y(\delta_5) = \alpha_1 + \alpha_3 + \alpha_4 + \alpha_5, \\ \delta_9 &= s_2(\delta_8) = \alpha_1 + \alpha_2 + \alpha_3 + \alpha_4 + \alpha_5, \delta_{10} = s_4(\delta_9) = \alpha_1 + \alpha_2 + \alpha_3 + 2\alpha_4 + \alpha_5, \\ \delta_{11} &= u_Y(\delta_{10}) = \alpha_1 + \alpha_2 + 2\alpha_3 + 2\alpha_4 + \alpha_5, \\ \delta_{12} &= u_X(\delta_{11}) = \alpha_1 + \alpha_2 + 2\alpha_3 + 2\alpha_4 + \alpha_5 + \alpha_6.\end{aligned}$$

On the other hand, the orbit $W^G \alpha_3$ contains the root $u_Y(\delta_4) = \alpha_4 + \alpha_5 = g(\delta_4)$. So, this orbit contains δ_4 and $g(\delta_4)$. By Lemma 4.19(2) it is stable by g , hence it contains the images by g of the 12 above enumerated roots, that is, the positive roots $\alpha = \sum_{i=1}^6 \lambda_i \alpha_i$ such that $\lambda_1 + \lambda_3 < \lambda_5 + \lambda_6$. This completes the proof of Case (iv). \square

We turn now to study the pairs (Γ, G) of Theorem 1.3 where Γ is of affine type, that is, the pairs of Case (v), Case (vi), Case (vii) and Case (viii). The proof of the following is left to the reader.

Lemma 4.21.

- (1) Let $x, y \in V$ and $w \in \text{GL}(V)$ such that $w(x) = x + y$ and $w(y) = y$. Then $w^k(x) = x + ky$ for all $k \in \mathbb{Z}$.
- (2) Let $x, x', y \in V$ and $w, w' \in \text{GL}(V)$ such that $w(x) = x' + y$, $w'(x') = x + y$ and $w(y) = w'(y) = y$. Then $(w'w)^k(x) = x + 2ky$, $w(w'w)^k(x) = x' + (2k + 1)y$, $(ww')^k(x') = x' + 2ky$, and $w'(ww')^k(x') = x + (2k + 1)y$, for all $k \in \mathbb{Z}$.

Lemma 4.22. *If (Γ, G) is one of the pairs of Case (v), Case (vi), Case (vii) and Case (viii) of Theorem 1.3, then (Γ, G) has the $\widetilde{\Phi}^+$ -basis property.*

Proof. We set $S_1 = S \setminus \{0\}$, $\Gamma_1 = \Gamma_{S_1}$, $\mathbb{B}_1 = \mathbb{B}_{S_1}$, $W_1 = W_{S_1} = W(\mathbb{B}_1)$ and $\Phi_1 = \Phi_{S_1} = \Phi(\mathbb{B}_1)$. Note that the elements of G fix 0 and leave invariant S_1 . We denote by G_1 the subgroup of $\text{Sym}(\Gamma_1)$ induced by G .

Let β be the greatest root of Φ_1 and let $\delta = \alpha_0 + \beta$. Recall that $\langle \alpha, \delta \rangle = 0$ for all $\alpha \in \Phi$ and $w(\delta) = \delta$ for all $w \in W$ (see the proof of Lemma 4.10). Here are the values of δ according to Γ .

- If $\Gamma = \widetilde{A}_{2m+1}$ ($m \geq 1$), then $\delta = \alpha_0 + \alpha_1 + \alpha_2 + \cdots + \alpha_{2m+1}$.
- If $\Gamma = \widetilde{D}_m$ ($m \geq 4$), then $\delta = \alpha_0 + \alpha_1 + 2\alpha_2 + \cdots + 2\alpha_{m-2} + \alpha_{m-1} + \alpha_m$.

- If $\Gamma = \widetilde{E}_6$, then $\delta = \alpha_0 + \alpha_1 + 2\alpha_2 + 2\alpha_3 + 3\alpha_4 + 2\alpha_5 + \alpha_6$.

The following claim is proved in Kac [18, Prop. 6.3(a)].

Claim 4.23. *We have $\Phi = \{\alpha + k\delta \mid \alpha \in \Phi_1 \text{ and } k \in \mathbb{Z}\}$.*

As in the proof of Lemma 4.20 it suffices to show that there exists a subset $X \subset S$ such that $\Phi = \cup_{s \in X} W^G \alpha_s$. For that we will use the following.

Claim 4.24. *Let Y be a subset of S_1 such that $\Phi_1 = \cup_{s \in Y} W_1^{G_1} \alpha_s$.*

- (1) *Suppose that $\alpha_s + \delta \in W^G \alpha_s$ for all $s \in Y$. Then $\Phi = \cup_{s \in Y} W^G \alpha_s$.*
- (2) *Suppose that there exists $t \in Y$ such that $\alpha_s + \delta \in W^G \alpha_s$ for all $s \in Y \setminus \{t\}$, $\alpha_t + \delta \in W^G \alpha_0$ and $\alpha_0 + \delta \in W^G \alpha_t$. Then $\Phi = \cup_{s \in Y \cup \{0\}} W^G \alpha_s$.*

Proof of Claim 4.24. By Claim 4.23 each element of Φ is written $\alpha + k\delta$ with $\alpha \in \Phi_1$ and $k \in \mathbb{Z}$. By assumption there exist $s \in Y$ and $w_1 \in W_1^{G_1}$ such that $\alpha = w_1(\alpha_s)$. Since δ is fixed by the elements of W we have $\alpha + k\delta = w_1(\alpha_s) + k\delta = w_1(\alpha_s + k\delta)$. Under the assumptions of Part (1) there exists $w \in W^G$ such that $\alpha_s + \delta = w(\alpha_s)$. It follows from Lemma 4.21 (1) that $\alpha_s + k\delta = w^k(\alpha_s)$, hence $\alpha + k\delta = w_1(\alpha_s + k\delta) = (w_1 w^k)(\alpha_s) \in W^G \alpha_s$. Now we assume the hypothesis of Part (2). If $s \neq t$, then we show as in the proof of Part (1) that $\alpha + k\delta \in W^G \alpha_s$. Suppose that $s = t$. Then there exist $w, w' \in W^G$ such that $\alpha_t + \delta = w(\alpha_0)$ and $\alpha_0 + \delta = w'(\alpha_t)$. It follows from Lemma 4.21 (2) that $\alpha_t + k\delta$ lies in $W^G \alpha_t$ if k is even and $\alpha_t + k\delta$ lies in $W^G \alpha_0$ if k is odd. Now, $\alpha + k\delta = w_1(\alpha_t + k\delta)$, hence $\alpha + k\delta \in W^G \alpha_t \cup W^G \alpha_0$. This ends the proof of Claim 4.24. \square

The rest of the proof of Lemma 4.22 is case by case.

Case (v). We show that $\Phi = W^G \alpha_0 \cup W^G \alpha_m \cup W^G \alpha_{m+1}$. The orbits of S under the action of G are $\{0\}, X_1 = \{1, 2m+1\}, \dots, X_m = \{m, m+2\}, \{m+1\}$. Thus $W^G = \langle s_0, u_{X_1}, \dots, u_{X_m}, s_{m+1} \rangle$. We also know that $\Phi_1 = W_1^{G_1} \alpha_m \cup W_1^{G_1} \alpha_{m+1}$ (see the proof of Lemma 4.20). So, by Claim 4.24 it suffices to show that $\alpha_0 + \delta \in W^G \alpha_{m+1}$, $\alpha_{m+1} + \delta \in W^G \alpha_0$ and $\alpha_m + \delta \in W^G \alpha_m$. This follows from the following formulas.

$$\begin{aligned} \alpha_0 + \delta &= (s_0 u_{X_1} \cdots u_{X_m})(\alpha_{m+1}), \quad \alpha_{m+1} + \delta = (s_{m+1} u_{X_m} \cdots u_{X_1})(\alpha_0), \\ \alpha_m + \delta &= (u_{X_m} \cdots u_{X_1} s_0 u_{X_1} \cdots u_{X_m} s_{m+1})(\alpha_m). \end{aligned}$$

Case (vi). We show that $\Phi = W^G \alpha_{m-2} \cup W^G \alpha_m$. The orbits of S under the action of G are $\{0\}, \{1\}, \{2\}, \dots, \{m-2\}, X = \{m-1, m\}$. Thus $W^G = \langle s_0, s_1, s_2, \dots, s_{m-2}, u_X \rangle$. On the other hand, we know that $\Phi_1 = W_1^{G_1} \alpha_{m-2} \cup W_1^{G_1} \alpha_m$ (see the proof of Lemma 4.20).

So, by Claim 4.24 it suffices to show that $\alpha_{m-2} + \delta \in W^G \alpha_{m-2}$ and $\alpha_m + \delta \in W^G \alpha_m$. This follows from the following formulas.

$$\begin{aligned}\alpha_{m-2} + \delta &= (s_{m-2}s_{m-3} \cdots s_2s_0u_Xs_1s_2 \cdots s_{m-3})(\alpha_{m-2}), \\ \alpha_m + \delta &= (u_Xs_{m-2} \cdots s_2s_0u_Xs_1s_2 \cdots s_{m-2})(\alpha_m).\end{aligned}$$

Case (vii). The orbits of S under the action of G are $X = \{1, 3, 4\}, \{2\}, \{0\}$, hence $W^G = \langle u_X, s_2, s_0 \rangle$. We show that $\Phi = \cup_{i=1}^4 W^G \alpha_i$. We know that $\Phi_1 = \cup_{i=1}^4 W_1^{G_1} \alpha_i$ (see the proof of Lemma 4.20). So, by Claim 4.24 it suffices to show that $\alpha_i + \delta \in W^G \alpha_i$ for all $i \in \{1, 2, 3, 4\}$. We have $\alpha_1 + \delta = (u_Xs_2s_0u_Xs_2)(\alpha_1) \in W^G \alpha_1$. Similarly, $\alpha_3 + \delta \in W^G \alpha_3$ and $\alpha_4 + \delta \in W^G \alpha_4$. Finally, $\alpha_2 + \delta = (s_2s_0u_X)(\alpha_2) \in W^G \alpha_2$.

Case (viii). We show that $\Phi = W^G \alpha_3 \cup W^G \alpha_4$. The orbits of S under the action of G are $X = \{1, 6\}, Y = \{3, 5\}, \{0\}, \{2\}, \{4\}$. Thus $W^G = \langle u_X, u_Y, s_0, s_2, s_4 \rangle$. On the other hand $\Phi_1 = W_1^{G_1} \alpha_3 \cup W_1^{G_1} \alpha_4$ (see the proof of Lemma 4.20). So, by Claim 4.24 it suffices to show that $\alpha_3 + \delta \in W^G \alpha_3$ and $\alpha_4 + \delta \in W^G \alpha_4$. We use the notations of the proof of Case (iv) of Lemma 4.20. We check that $\alpha_3 + \delta = (u_Ys_4s_2s_0)(g(\delta_{12}))$. Thus, since $g(\delta_{12}) \in W_1^{G_1} \alpha_3$, we have $\alpha_3 + \delta \in W^G \alpha_3$. Similarly, we check that $\alpha_4 + \delta = (s_4s_2s_0)(\gamma_{10})$. Thus, since $\gamma_{10} \in W_1^{G_1} \alpha_4$, we have $\alpha_4 + \delta \in W^G \alpha_4$. \square

The last two cases of Theorem 1.3, those with locally spherical Coxeter graphs (Case (ix) and Case (x)), are easily deduced from Case (i) and Case (ii) as we will see next.

Lemma 4.25. *If (Γ, G) is one of the pairs of Case (ix) and Case (x) of Theorem 1.3, then (Γ, G) has the $\widehat{\Phi}^+$ -basis property.*

Proof. As ever, it suffices to show that for each $\alpha \in \Phi$ there exist $s \in S$ and $w \in W^G$ such that $\alpha = w(\alpha_s)$.

Case (ix). Let $n \geq 1$. We set $S_n = \{-n, \dots, -1, 0, 1, \dots, n\}$, $\Gamma_n = \Gamma_{S_n}$, $\mathbb{B}_n = \mathbb{B}_{S_n}$, $W_n = W_{S_n} = W(\mathbb{B}_n)$, $\Phi_n = \Phi_{S_n} = \Phi(\mathbb{B}_n)$ and $\Pi_n = \{\alpha_s \mid s \in S_n\}$. We denote by V_n the vector subspace of V spanned by Π_n . Recall that $\Phi_n = V_n \cap \Phi$ (see Proposition 2.3). Note that the elements of G leave invariant the set S_n . We denote by G_n the subgroup of $\text{Sym}(\Gamma_n)$ induced by G . Let $\alpha \in \Phi$. Since α has finite support, there exists $n \geq 1$ such that $\alpha \in V_n \cap \Phi = \Phi_n$. Then by Lemma 4.20 there exist $s \in S_n \subset S$ and $w \in W_n^{G_n} \subset W^G$ such that $\alpha = w(\alpha_s)$.

Case (x). We argue as in Case (ix). Let $n \geq 4$. We set $S_n = \{1, 2, \dots, n\}$, $\Gamma_n = \Gamma_{S_n}$, $\mathbb{B}_n = \mathbb{B}_{S_n}$, $W_n = W_{S_n} = W(\mathbb{B}_n)$, $\Phi_n = \Phi_{S_n} = \Phi(\mathbb{B}_n)$ and $\Pi_n = \{\alpha_s \mid s \in S_n\}$, and we denote by V_n the vector subspace of V spanned by Π_n . The elements of G leave invariant the set S_n , and we denote by G_n the subgroup of $\text{Sym}(\Gamma_n)$ induced by G . Let $\alpha \in \Phi$. Since

α has finite support, there exists $n \geq 4$ such that $\alpha \in V_n \cap \Phi = \Phi_n$. Then by Lemma 4.20 there exist $s \in S_n \subset S$ and $w \in W_n^{G_n} \subset W^G$ such that $\alpha = w(\alpha_s)$. \square

Proof of Theorem 1.3. It directly follows from Lemma 4.18, Lemma 4.20, Lemma 4.22 and Lemma 4.25. \square

References

- [1] Stephen J. Bigelow. Braid groups are linear. *J. Am. Math. Soc.*, 14(2):471–486, 2001.
- [2] Nicolas Bourbaki. *Éléments de mathématique. Fasc. XXXIV. Groupes et algèbres de Lie. Chapitre IV: Groupes de Coxeter et systèmes de Tits. Chapitre V: Groupes engendrés par des réflexions. Chapitre VI: systèmes de racines*, volume 1337 of *Actualités Scientifiques et Industrielles*. Hermann, 1968.
- [3] Anatole Castella. *Automorphismes et admissibilité dans les groupes de Coxeter et les monoïdes d’Artin-Tits*. PhD thesis, Université de Paris-Sud (France), 2006.
- [4] Anatole Castella. On Lawrence-Krammer representations. *J. Algebra*, 322(10):3614–3639, 2009.
- [5] Anatole Castella. Twisted Lawrence-Krammer representations. <https://arxiv.org/abs/1711.09860>, 2017.
- [6] Arjeh M. Cohen and David B. Wales. Linearity of Artin groups of finite type. *Isr. J. Math.*, 131:101–123, 2002.
- [7] John Crisp. Symmetrical subgroups of Artin groups. *Adv. Math.*, 152(1):159–177, 2000.
- [8] John Crisp. Erratum to: “Symmetrical subgroups of Artin groups”. *Adv. Math.*, 179(2):318–320, 2003.
- [9] Michael W. Davis. *The geometry and topology of Coxeter groups*, volume 32 of *London Mathematical Society Monographs*. Princeton University Press, 2008.
- [10] Patrick Dehornoy and Luis Paris. Gaussian groups and Garside groups, two generalisations of Artin groups. *Proc. Lond. Math. Soc.*, 79(3):569–604, 1999.
- [11] Vinay V. Deodhar. On the root system of a Coxeter group. *Commun. Algebra*, 10(6):611–630, 1982.
- [12] François Digne. On the linearity of Artin braid groups. *J. Algebra*, 268(1):39–57, 2003.

- [13] Olivier Geneste and Luis Paris. Coxeter groups, symmetries, and rooted representations. *Commun. Algebra*, 46(5):1996–2002, 2018.
- [14] Jean-Yves Hée. Système de racines sur un anneau commutatif totalement ordonné. *Geom. Dedicata*, 37(1):65–102, 1991.
- [15] Jean-Yves Hée. Sur la torsion de Steinberg-Ree des groupes de Chevalley et des groupes de Kac-Moody. Thèse de Doctorat d'État, Université de Paris-Sud (France), 1993.
- [16] Jean-Yves Hée. Une démonstration simple de la fidélité de la représentation de Lawrence-Krammer-Paris. *J. Algebra*, 321(3):1039–1048, 2009.
- [17] James E. Humphreys. *Reflection groups and Coxeter groups*, volume 29 of *Cambridge Studies in Advanced Mathematics*. Cambridge University Press, 1990.
- [18] Victor G. Kac. *Infinite-dimensional Lie algebras*. Cambridge University Press, third edition, 1990.
- [19] Daan Krammer. *The conjugacy problem for Coxeter groups*. PhD thesis, Universiteit Utrecht (Netherlands), 1994.
- [20] Daan Krammer. Braid groups are linear. *Ann. Math.*, 155(1):131–156, 2002.
- [21] Daan Krammer. The conjugacy problem for Coxeter groups. *Groups Geom. Dyn.*, 3(1):71–171, 2009.
- [22] Ruth J. Lawrence. Homological representations of the Hecke algebra. *Commun. Math. Phys.*, 135(1):141–191, 1990.
- [23] Jean Michel. A note on words in braid monoids. *J. Algebra*, 215(1):366–377, 1999.
- [24] B. Mühlherr. Coxeter groups in Coxeter groups. In *Finite geometry and combinatorics (Deinze, 1992)*, volume 191 of *London Mathematical Society Lecture Note Series*, pages 277–287. Cambridge University Press, 1993.
- [25] Luis Paris. Artin monoids inject in their groups. *Comment. Math. Helv.*, 77(3):609–637, 2002.

O. Geneste & J.-Y. Hée & L. Paris

OLIVIER GENESTE
IMB, UMR 5584, CNRS
Université Bourgogne Franche-Comté
21000 Dijon
FRANCE
o.geneste@gmail.com

JEAN-YVES HÉE
LAMFA, UMR 7352, CNRS
Université de Picardie Jules Verne
80039 Amiens
FRANCE
jean-yves.hee@u-picardie.fr

LUIS PARIS
IMB, UMR 5584, CNRS
Université Bourgogne Franche-Comté
21000 Dijon
FRANCE
lparis@u-bourgogne.fr