

ULRICH HUCKENBECK

**On geometric automata which can nondeterministically  
choose auxiliary points**

*RAIRO. Informatique théorique et applications*, tome 24, n° 5 (1990),  
p. 471-487

[http://www.numdam.org/item?id=ITA\\_1990\\_\\_24\\_5\\_471\\_0](http://www.numdam.org/item?id=ITA_1990__24_5_471_0)

© AFCET, 1990, tous droits réservés.

L'accès aux archives de la revue « RAIRO. Informatique théorique et applications » implique l'accord avec les conditions générales d'utilisation (<http://www.numdam.org/conditions>). Toute utilisation commerciale ou impression systématique est constitutive d'une infraction pénale. Toute copie ou impression de ce fichier doit contenir la présente mention de copyright.

NUMDAM

Article numérisé dans le cadre du programme  
Numérisation de documents anciens mathématiques

<http://www.numdam.org/>

## ON GEOMETRIC AUTOMATA WHICH CAN NONDETERMINISTICALLY CHOOSE AUXILIARY POINTS (\*)

by Ulrich HUCKENBECK <sup>(1)</sup>

Communicated by J. BERSTEL

---

*Abstract.* – In this article we present and investigate abstract geometrical automata which can simulate the use of compass and ruler; moreover they have the following capability: If a point  $Q$  is given they can nondeterministically choose some (auxiliary) point  $Q' \in f(Q)$  where  $f$  is an element of a fixed set  $\mathcal{F}$  of functions; this machine will be called by  $\mathcal{F}$ -GCM<sub>0</sub>.

We shall mainly compare the powers of these machines: For a "large" class of pairs  $(\mathcal{F}, \mathcal{F}')$  we shall show that the concept of the  $\mathcal{F}$ -GCM<sub>0</sub> and that of the  $\mathcal{F}'$ -CGM<sub>0</sub> have the same capabilities. On the other hand we shall prove some general results about the different power of  $\mathcal{F}$ -GCM<sub>0</sub>'s and  $\mathcal{F}'$ -GCM<sub>0</sub>'s; these results are obtained by topological and fixed point theoretical means.

*Résumé.* – Dans cet article, nous présentons et étudions des automates abstraits géométriques qui peuvent imiter l'emploi du compas et de la règle; en outre, ces machines ont la capacité suivante: Si un point  $Q$  est donné, ils peuvent faire un choix non-déterministe d'un point (auxiliaire)  $Q' \in f(Q)$ , où  $f$  est un élément d'un ensemble fixe  $\mathcal{F}$  de fonctions.

Avant tout, nous voulons comparer les capacités de ces machines: Pour une grande classe de paires  $(\mathcal{F}, \mathcal{F}')$  nous démontrons que les modèles  $\mathcal{F}$ -GCM<sub>0</sub> et  $\mathcal{F}'$ -GCM<sub>0</sub> sont équivalents. D'autre part, nous prouvons quelques théorèmes généraux qui affirment que les capacités de certaines  $\mathcal{F}$ -GCM<sub>0</sub>'s et  $\mathcal{F}'$ -GCM<sub>0</sub>'s sont différentes; à cet effet, nous appliquons des méthodes topologiques et la théorie des points fixes.

### INTRODUCTION

One of the fundamental problems of Computational Geometry is the design of appropriate abstract geometric automata. The most well-known of them is the modified RAM described in [6], p. 28. This machine can apply

---

(\*) Received November 1988, revised March 1989.

(<sup>1</sup>) University at Würzburg, Department of Computer Science, Am Hubland, D-8700 Würzburg, F.R.G.

$+$ ,  $-$ ,  $*$ ,  $/$  and comparisons to reals. But all of these operations are arithmetic; therefore they are not very adequate to *geometric* problems.

This shortcoming is avoided e. g. in [7], p. 260 where P. Schreiber presents his geometric Turing machine; this automaton can modify tiles with small drawings in them; it is clear that this is a geometric operation. In opposite to this, the works [2], [3] and [4] do not deal with Turing machines but with geometrical register machines whose primitives correspond to the use of the most important drawing tools: compass and ruler; in particular, the thesis [2] was influenced by the overview given in [8], p. 232-233.

In this paper we want to extend these register machines: in addition to the normal operations with compass and ruler, our machines can nondeterministically choose auxiliary points within particular sets of points; e. g. the machine in Example 1.4 will be able to take a point  $Q'$  on the  $x$ -axis which is unequal to a given point  $Q$ . Obviously this kind of operations enable our automata to simulate the behaviour of a human drawer very realistically.

Consequently our investigations are not only relevant for Computational Geometry; they are also very interesting for Euclidian Geometry, and in the proofs to our last three theorems there even occur some surprising aspects of topology and of fixed point theory.

The structure of this paper is the following: In Chapter 1, we present the automaton ' $GCM_0$ ' and its extended version ' $\mathcal{F}$ - $GCM_0$ '; we investigate some basic properties of them. In Chapter 2, we shall compare the powers of our machines. We first shall see that a large class of  $GCM_0$ -extensions are equivalent; in the last part of Chapter 2, however, we prove some general theorems about *different* powers of different  $GCM_0$ -extensions. By the way, a similar result can be found in the last part of [5].

Let us finish our introduction with the definition of some basic terms:

For every set  $A$ , the set  $\Pi(A)$  contains all *subsets of  $A$  which are not empty*.

For every relation  $R \subseteq A \times B$  and  $a \in A$  we define  $R \langle a \rangle := \{b \in B \mid (a, b) \in R\}$ . Moreover the *domain of definition* is given as follows:  $\text{def}(R) := \{a \in A \mid R \langle a \rangle \neq \emptyset\}$ .

Let  $\mathbb{P}$  be the *Euclidian plane*,  $\mathbb{G}$  the set of the *straight lines* and  $\mathbb{K}$  the set of the *circular lines* in  $\mathbb{P}$ .  $G_x$  is the  $x$ -axis and  $G_y$  is the  $y$ -axis of the cartesian coordinate system.

Let  $Q_1, Q_2, \tilde{Q} \in \mathbb{P}$ ; then  $\overline{Q_1, Q_2}$  is the (*closed*) *line segment* between  $Q_1$  and  $Q_2$ ; in the degenerate case of  $Q_1 = Q_2$ , this line segment collapses to the point  $Q_1$ . If  $Q_1 \neq Q_2$ , we additionally define  $(Q_1, Q_2)$  as the *straight line* through

$Q_1, Q_2$  and  $(\bar{Q}; Q_1, Q_2)$  as the *circular line* centered in  $\bar{Q}$  with radius = length of  $Q_1, Q_2$ .

For every  $r > 0$  we define  $B(0, r)$  as the *open circular disk* around  $(0|0)$  with radius  $r$ ; its *closure* is  $\bar{B}(0, r)$ , and  $S(0, r)$  is the *corresponding circular line*.

A partial function  $F: \mathbb{P} \rightarrow \mathbb{P}$  is called *rational integer* (r.i.) if there exist polynomials  $\alpha, \beta, \gamma, \delta: \mathbb{R}^2 \rightarrow \mathbb{R}$  with integer coefficients such that for every  $Q = (x|y) \in \text{def}(F)$  the following is true:

$$F(Q) = \left( \frac{\alpha(x, y)}{\beta(x, y)} \middle| \frac{\gamma(x, y)}{\delta(x, y)} \right).$$

## 1. THE DEFINITION OF OUR GEOMETRICAL AUTOMATA AND THEIR BASIC PROPERTIES

We begin this paragraph with the definition of the  $CGM_0$ . This is an abstract automaton which can simulate the use of compass and ruler. (The subscript '0' is to make it possible to modify this definition, i.e. to create a  $GCM_1$  or a  $GCM_2$  etc. basing on other drawing tools. E.g. this is done in [3], Def. 2.2.)

DEFINITION 1.1: (See [3], Def. 2.1, [4], Definitions 2.1, 2.2).

A *Geometric Construction Machine of type 0* ( $GCM_0$ ) is an automaton with the following properties:

The machine has three types of *memory registers*, namely

$p_0, p_1, p_2, \dots$  for *points*,

$g_0, g_1, g_2, \dots$  for *straight lines* and

$k_0, k_1, k_2, \dots$  for *circles*.

Note that we distinguish between the *registers* and their *contents*. Therefore we denote the current contents of a register by the corresponding capital letter with a subscript; e.g.  $P_{17}$  is the point stored in  $p_{17}$ , and the current circle in  $k_{39}$  is  $K_{39}$ .

The  $GCM_0$  has the following capabilities:

(1) intersecting two lines, e.g.  $pi: \in ki' \cap gi''$ ; (If these two lines have exactly two points of intersection, then  $P_i$  is chosen nondeterministically; this situation can arise if one of the lines is a circle.)

(2) finding the second of two points of intersection if one of them ( $= P_j$ ) is already given; i.e.  $pi: \in gi' \cap ki'' \setminus \{pj\}$ ;  $pi: \in ki' \cap gi'' \setminus \{pj\}$ ;  $pi: \in ki' \cap ki'' \setminus \{pj\}$ ;

(3) creating the straight line with two given points on it, i.e.  $gi: = (pi', pi'')$ ;

(4) generating the circle  $K_j = (P_i; P_i', P_i'')$ ; this is effected by the instruction  $kj := (pi; pi', pi'')$ ;

(5) copying registers (e. g.  $g\ 12 := g\ 3$ );, output of data (e. g. write ( $k\ 47$ );), executing dummy statements (nop;).

The *program* of such a  $GCM_0$  is a finite sequence  $(\varphi_1 \dots \varphi_n)$  where the statements  $\varphi_1, \dots, \varphi_{n-1}$  are according to (1)-(5); the last instruction  $\varphi_n$  is 'end'.

Before executing its program, the registers are *initialized* such that all important geometric objects of the cartesian coordinate system are available. In particular,

$p\ 0, p\ 3, p\ 6, p\ 9, \dots$  are initialized with  $(0|0)$ ,  
 $p\ 1, p\ 4, p\ 7, p\ 10, \dots$  are initialized with  $(1|0)$ ,  
 $p\ 2, p\ 5, p\ 8, p\ 11, \dots$  are initialized with  $(0|1)$ ,  
 $g\ 0, g\ 2, g\ 4, g\ 8, \dots$  are initialized with  $G_x$ ,  
 $g\ 1, g\ 3, g\ 5, g\ 9, \dots$  are initialized with  $G_y$ ,

$k\ 0, k\ 1, k\ 2, k\ 3, \dots$  are initialized with the unit circle around  $(0|0)$ .

After this, the  $GCM_0$  loads the input *points*  $P_1, \dots, P_n$  into the registers  $p\ 1, \dots, p\ n$  resp.; the input *straight lines*  $G_1, \dots, G_n$  and the input *circles*  $K_1, \dots, K_n$  are loaded into  $g\ 1, \dots, g\ n'$ ,  $k\ 1, \dots, k\ n''$  resp. The remaining registers keep the contents effected by the initialization.

Then the *program* of the  $GCM_0$  is executed. ■

*Remark 1.2:* From the definition of the  $GCM_0$  the following problem arises: How does the automaton behave if some instruction cannot be executed correctly (e. g. finding the point of intersection of two disjoint circles)? This problem is treated with the help of the three states  $N$  (=normal),  $E$  (=error) and  $F$  (=final). During its work the  $GCM'_0$  is in the state  $N$ . If it has to execute a "forbidden" instruction, then it falls into the state  $E$ ; the state  $F$ , however, occurs if the machine arrives at the 'end'-statement without any incident.

A complete list of the forbidden instructions can be found in [3], Def. 2.1. ■

We next introduce that extension of the  $GCM_0$ 's which is the main subject of this paper:

DEFINITION 1.3: (a) Let  $\mathcal{F}$  be a set of functions  $f: \mathbb{P} \rightarrow \Pi(\mathbb{P})$ . Then an  $\mathcal{F}$ -GCM<sub>0</sub> is a GCM<sub>0</sub> with the following additional type of instructions:

$$p_i := f(p_j); \quad (\text{where } f \in \mathcal{F}). \quad (*)$$

This means that the machine nondeterministically chooses the (auxiliary) point  $P_i$  within the set  $f(P_j) \neq \emptyset$ .

(b) It should be mentioned that this definitions can easily be generalized by considering sets  $\mathcal{F}$  of functions  $f: U \rightarrow \Pi(V)$  where  $U = \mathbb{P}^n \times \mathbb{G}^{n'} \times \mathbb{K}^{n''}$  and  $V = \mathbb{P}^m \times \mathbb{G}^{m'} \times \mathbb{K}^{m''}$ . These machines can choose a tuple  $v$  within  $f(u) \subseteq V$ ; this tuple  $v$  consists of  $m$  points,  $m'$  lines and  $m''$  circles.

(c) In this paper we only deal with those sets  $\mathcal{F}$  which are defined in (a), and we very often consider the case that  $\mathcal{F}$  only has one element  $f$ . Then we write  $f$ -GCM<sub>0</sub> instead of  $\{f\}$ -GCM<sub>0</sub>. ■

In reality, even the class of machines given in 1.3. (c) is too general for us; therefore we shall concentrate ourselves on the following special case:  $\mathcal{F} = \{f\}$ , and  $f: \mathbb{P} \rightarrow \Pi(\mathbb{P})$  has the very simple structure  $f(Q) = A \setminus \{Q\}$ ; this means that  $f$  helps to find a point  $Q'$  which lies in a fixed set  $A$  and is different from the given point  $Q$ . Note that the additional condition  $Q \neq Q'$  is very useful since it allows to construct the line  $(Q, Q')$  and circles  $(\tilde{Q}; Q, Q')$  without entering the ERROR-state  $E$ ; e.g. the correctness of the second program line in the next example is based on the fact that  $P_1 \neq P_2$ .

Let us now consider this example of an  $\mathcal{F}$ -GCM<sub>0</sub>  $M$ . It will make the previous definitions more transparent; furthermore, the machine  $M$  will simulate a human drawer very realistically:

Example 1.4: Let  $f: \mathbb{P} \rightarrow \Pi(\mathbb{P}), Q \mapsto G_x \setminus \{Q\}$ . Then we consider a machine  $M$  which constructs the perpendicular projection of any point  $(x|y) = P_1 \in \mathbb{P}$  onto  $G_x$ , i.e.,  $M$  outputs  $(x|0)$ . The program of  $M$  is the following:

```
p2 := f(p1);
g1 := (p1, p2);
k1 := (p2; p1, p2);
p3 := e k1 n g1 \ {p1};
k2 := (p1; p1, p3);
```

(Note that  $K_2$  is large enough to intersect  $G_x = G_0$  twice.)

```
p4 := e g0 n k2;
p5 := e g0 n k2 \ {p4};
```

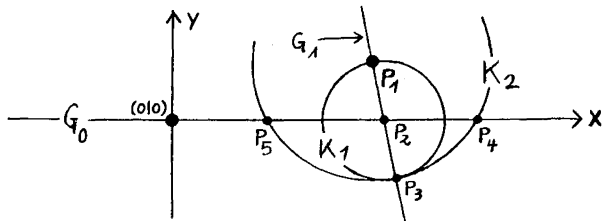

Figure 1a.

(The next step is constructing the mid-perpendicular of  $P_4$  and  $P_5$ .)

```

k4 := (p4;p4,p5);
k5 := (p5;p4,p5);
p6 := k4 n k5;
p7 := k4 n k5 \ {p6};
g7 := (p7,p6);
p9 := g7 n g0;
write(p9);
end.
    
```

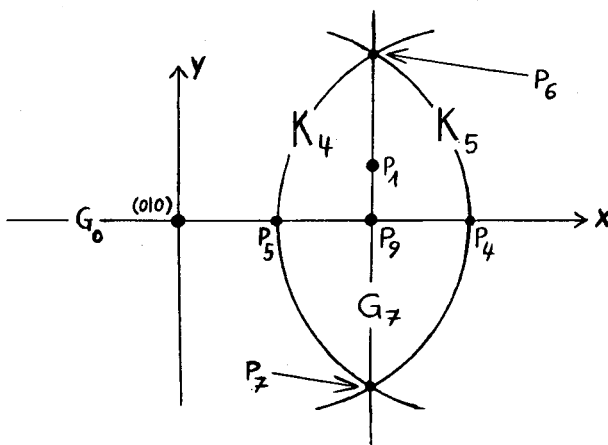

Figure 1b.

We now describe the *outputs* of a  $\mathcal{F}$ -GCM<sub>0</sub>. For this end we make the following definition:

DEFINITION 1.5: Let  $n, n', n'', m, m', m'' \in \mathbb{N}$  and let  $U := \mathbb{P}^n \times \mathbb{G}^{n'} \times \mathbb{K}^{n''}$  and  $V := \mathbb{P}^m \times \mathbb{G}^{m'} \times \mathbb{K}^{m''}$ . Given the relation  $R \subseteq U \times V$ .

Then we say that a  $\mathcal{F}$ -GCM<sub>0</sub>  $M$  constructs the relation  $R$  iff the following conditions are satisfied:

- (i) For every  $u \in \text{def}(R)$  and every sequence of nondeterministic decisions, the machine  $M$  arrives at the state  $F$ ; this means that never a forbidden operation occurs if  $u \in \text{def}(R)$  is input.
- (ii)  $R \langle u \rangle$  is *exactly* the set of those outputs which are effected by a sequence of nondeterministic decisions.

This means that  $R = \left\{ (u, v) \left| \begin{array}{l} \text{After input of } u, \text{ the machine } M \\ \text{cannot enter the state } E, \text{ and } v \text{ is a} \\ \text{possible output of } M. \end{array} \right. \right\}$  ■

Remark 1.6:

(a) Let  $R$  be a partial function, i.e.  $R: U \dashrightarrow V$ . Then condition (ii) of Def. 1.5 means that  $R(u)$  has to be output for *every* possible sequence of nondeterministic decisions; this definition is different from the usual ones where only one of these sequences has to effect the desired output  $R(u)$ . But although this point of view is unusual in Automata Theory, it very often occurs in Euclidean Geometry where the result of a construction must indeed

be the same for every (nondeterministic) choice of auxiliary points. A typical example is the machine in 1.4, which constructs the projection function  $F: \mathbb{P} \rightarrow \mathbb{P}, P_1 = (x|y) \mapsto (x|0)$ . By the way, this point of view was also treated in [9].

(b) The machine  $M$  in Remark 2.2(c) constructs a relation  $R$  which is not a function; it is  $R = \{(P_1, P_3) \mid P_3 \in S(0, 1) \setminus \{P_1\}\}$ .

A further example can be found in [4, Example 2.4] where a  $CGM_0$  constructs the relation  $\{((P_1, P_2), P_3) \mid P_1 \neq P_2 \text{ and } P_3 \text{ is the third point of the equilateral triangle } (P_1, P_2, P_3)\}$ .

At the end of this paragraph, we deal with a basic theorem about the power of  $f-GCM_0$ 's. We want to show that a particular class of  $f-GCM_0$ 's is able to construct every rational integer function  $F: \mathbb{P} \rightarrow \mathbb{P}$ . At the first sight, this problem seems to be solvable easily even by a normal  $CGM_0$ . But in reality it is very difficult to avoid the error-state  $E$ ; this means that not all of these functions  $F$  are  $GCM_0$ -constructible (see the results (2.3.2) in [2] and 4.4 in [4]); therefore it is necessary to extend the  $GCM_0$  and to study its constructions carefully:

**THEOREM 1.7:** *Let  $A \subseteq \mathbb{P}$  such that there is a point  $Q_1$  with rational coordinates which is not situated in  $A$ . Let  $f: \mathbb{P} \rightarrow \Pi(\mathbb{P}), Q \mapsto A \setminus \{Q\}$ .*

*Then every rational integer function  $F: \mathbb{P} \rightarrow \mathbb{P}$  can be constructed with the help of an  $f-GCM_0$ .*

*Proof:* We do not want to prove this result in detail, but the reader will be able to do so with the help of the given references.

We first observe that  $M$  can create the following points if  $P_1 = (x|y)$  is input:  $Q_0 := (0|0)$ , the point  $Q_1$  with  $Q_1 \notin A, Q_2 \in f(P_1), Q_3 := P_1$  (see Fig. 2).

Then it is obvious that  $Q_1 \neq Q_2 \neq Q_3 = P_1$ .

According to Theorem 3.2 in [4] the machine  $M$  can construct the line  $PAR(Q, Q', G)$ , which is the parallel to the line  $G$  through the point  $Q \in \mathbb{P}$  where the auxiliary point  $Q' \in G \setminus \{Q\}$  is given. Consequently,  $M$  can generate parallels  $G_x^{(1)}$  and  $G_y^{(1)}$  to  $G_x$  and  $G_y$  resp. which pass  $Q_1$ . (If  $Q_1 = (0|0)$  then nothing must be done, otherwise  $M$  constructs  $PAR(Q_1, Q_0, G_x)$  and  $PAR(Q_1, Q_0, G_y)$ ). After this the following operations are executed recursively for  $i = 1, 2: \sqcup G_x^{(i+1)} := PAR(Q_{i+1}, Q_i, G_x^{(i)})$  and  $G_y^{(i+1)} := PAR(Q_{i+1}, Q_i, G_y^{(i)})$ . These constructions yield the horizontal line  $G_x^{(3)}$  and the vertical line  $G_y^{(3)}$ , and each of them passes  $Q_3 = P_1$ .

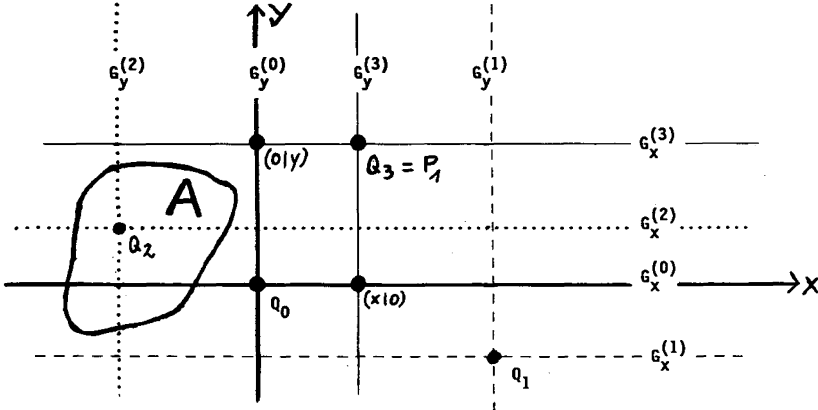

Figure 2.

Hence the points  $(x|0) \in G_x \cap G_y^{(3)}$  and  $(0|y) \in G_y \cap G_x^{(3)}$  are available. Then the results (2.3.11)–(2.3.14) in [2] and the theorems 3.5–3.7 in [4] imply that  $F$  is indeed constructible with the help of a  $f$ - $GCM_0$ .

2. COMPARING THE POWER OF  $\mathcal{F}$ - $GCM_0$ 'S

2.1. Basic terms and simple examples

In this chapter we compare the power of  $\mathcal{F}$ - $GCM_0$ 's with that of  $\mathcal{F}'$ - $GCM_0$ 's where  $\mathcal{F}$  and  $\mathcal{F}'$  are different. For this end we first precisely define what it means that “ $\mathcal{F}$  is as least as powerful as  $\mathcal{F}'$ ”.

DEFINITION 2.1: Let  $\mathcal{F}$  and  $\mathcal{F}'$  be two sets of functions from  $\mathbb{P}$  to  $\Pi(\mathbb{P})$ ; let  $f' \in \mathcal{F}'$ .

Moreover, let  $M$  be an  $\mathcal{F}$ - $GCM_0$ .

(a) We say that  $M$  simulates  $f'$  iff every input point  $P_1 \in \mathbb{P}$  effects an output  $\in f'(P_1)$ , and this is true for arbitrary nondeterministic decisions of  $M$ . (I. e.  $M$  constructs a relation  $R \subseteq \{(P_1, Q) | P_1 \in \mathbb{P} \text{ and } Q \in f'(P_1)\}$  with  $\text{def}(R) = \mathbb{P}$ . – Consequently the nondeterministic choice of a point  $Q \in f'(\tilde{Q})$  can be done by  $M$ .)

(b) We say that  $\mathcal{F}$  is at least as powerful as  $\mathcal{F}'$  ( $\mathcal{F}' \leq \mathcal{F}$ ) if every  $f' \in \mathcal{F}'$  can be simulated according to (a). (This means that for every  $f' \in \mathcal{F}'$ , the statement ‘ $pi \in f'(p)$ ’ can be replaced by instructions of  $\mathcal{F}$ - $GCM_0$ 's.)

(c) If we have two functions  $f, f'$  such that  $\{f\} \leq \{f'\}$  and  $\{f'\} \leq \{f\}$ , then we say that  $f$  and  $f'$  are equivalent ( $f \sim f'$ ). ■

*Remark 2.2:* (a). Let  $f(Q) \subseteq f'(Q)$  for every  $Q$ . Then  $\{f\}$  is indeed at least as powerful as  $\{f'\}$ , since the following  $\{f\}$ -GCM<sub>0</sub>  $M$  simulates  $f'$ :

$p2: \in f(p1)$ ; write ( $p2$ ); end.

(b) Part (a) of Definition 2.1 implies the following: If  $P_1$  is input, then the machine  $M$  simulating  $f'$  can only output points  $Q \in f'(P_1)$ . This trivial observation will be very useful in the proofs by contradiction in the last part of this article.

(c) The next two examples show that the following case can arise [cf. Part (a)]:  $(\forall Q \in \mathbb{P}) f(Q)$  is a proper subset of  $f'(Q)$ , but  $\{f'\}$  is at least as powerful as  $\{f\}$ . Our first example is  $f_1: Q \mapsto B(0, 1) \setminus \{Q\}$ ,  $f'_1: Q \mapsto \bar{B}(0, 1) \setminus \{Q\}$ , which can immediately be treated with the help of the next theorem. The second example is  $f_2: Q \mapsto S(0, 1) \setminus \{Q\}$  and  $f'_2 := f'_1$ . Then the following

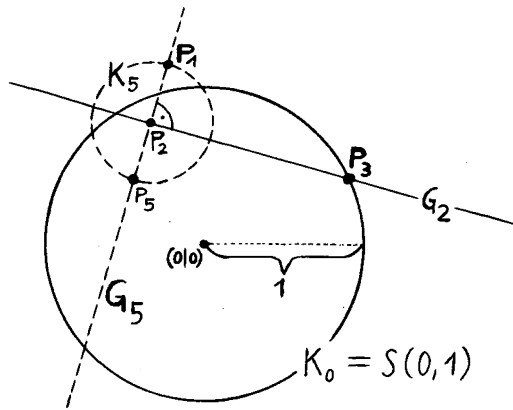

Figure 3.

$f'_2$ -GCM<sub>0</sub>  $M$  simulates  $\{f_2\}$  (Fig. 3): As just mentioned,  $M$  can simulate  $f'_1$ ; thus it can obtain a point  $P_2 \in B(0, 1)$  which is unequal to the input point  $P_1$ . After this  $M$  draws the circle  $K_5 := (P_2; P_2, P_1)$  and the line  $G_5 := (P_1, P_2)$ . The next steps are the constructions of  $P_5 \in K_5 \cap G_5 \setminus \{P_1\}$  and the mid-perpendicular  $G_2$  of  $P_1$  and  $P_5$ , which is also the perpendicular to  $G_5$  through  $P_2$ . Since  $P_2 \in B(0, 1)$ , the intersection  $G_5 \cap S(0, 1)$  consists of two points; then  $M$  finishes its work by constructing one of these points  $P_3 \in G_5 \cap K_0 = G_5 \cap S(0, 1)$ . Note now that  $P_3 \neq P_1$  because otherwise  $P_3 = P_1 \in G_5$  and  $P_1 = P_3 \in G_2$  so that  $P_1 \in G_2 \cap G_5$ ; but this would imply the wrong equation  $P_1 = P_2$ . Hence actually  $P_3 \in f_2(P_1)$ , i.e.,  $M$  works correctly. ■

We now finish our basic considerations and deal with the first substantial result of this paragraph:

**2.2. A “large” equivalence class with respect to ‘ $\sim$ ’**

**THEOREM 2.3:** *Let  $A_1, A_2 \subseteq \mathbb{P}$  be two bounded sets with nonempty open kernels. Let  $f_i: \mathbb{P} \rightarrow \Pi(\mathbb{P}), f_i(Q) := A_i \setminus \{Q\}$  ( $i=1,2$ ). Then  $f_1$  and  $f_2$  are equivalent.*

*Proof:* The assumption is symmetric with respect to  $f_1$  and  $f_2$ . Therefore it is sufficient to prove that  $\{f_1\} \leq \{f_2\}$ .

For this end we observe that there are closed circular disks  $D_1, D_2$  such that  $D_1 \subseteq A_1$  and  $A_2 \subseteq D_2$ .

It is clear that we can find a bijective affine mapping  $\tau: \mathbb{P} \rightarrow \mathbb{P}$  with the following properties:

- (1)  $\tau(D_2) \subseteq D_1$ ,
- (2)  $\tau$  is rational, i. e. for every  $(x|y)$  we have

$$\tau(x|y) = (\alpha x + \beta y + \gamma | \tilde{\alpha} x + \tilde{\beta} y + \tilde{\gamma}) \quad \text{where } \alpha, \beta, \gamma, \tilde{\alpha}, \tilde{\beta}, \tilde{\gamma} \in \mathbb{Q}.$$

Then the following is true:

- (3) Also  $\tau^{-1}$  is rational.

Obviously,  $\tau$  and  $\tau^{-1}$  are constructible with the help of  $f_2$ -GCM<sub>0</sub>'s; this follows from (2) and (3) and Theorem 1.7. So we can simulate  $f_1$  by the following  $f_2$ -GCM<sub>0</sub>  $M$  (see Fig. 4): If  $P_1$  is input then  $M$  first constructs  $Q := \tau^{-1}(P_1)$ . After this  $M$  chooses a point  $Q' \in f_2(Q)$ ; then  $Q' \in A_2 \subseteq D_2$  and

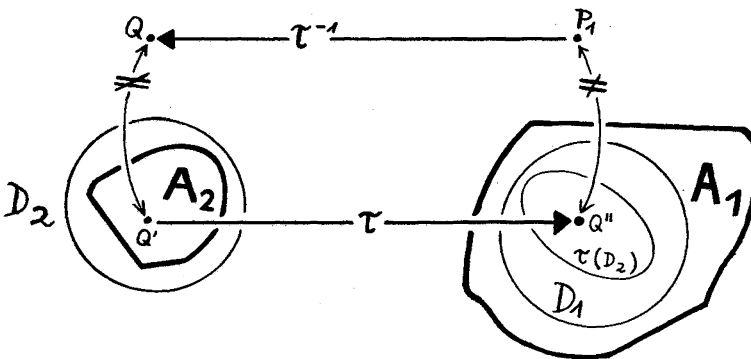

Figure 4.

$Q' \neq Q = \tau^{-1}(P_1)$ . Finally  $M$  constructs  $Q'' := \tau(Q')$ . Then  $Q'' \in A_1$  because of (1), and  $Q'' \neq P_1$  because  $\tau$  is injective. This means that indeed  $Q'' \in f_1(P_1)$ .

**2.3. Some results saying that not  $\{f'\} \leq \{f\}$**

In this part of Chapter 2 we show that particular functions  $f'$  cannot be simulated with the help of a  $f$ -GCM<sub>0</sub>  $M$ . For this end we shall replace the machine  $M$  by a ‘specialization’; this is a machine  $\tilde{M}$  which can nondeterministically choose among fewer objects than  $M$ . This shall enable us to control the behaviour of  $\tilde{M}$  better than that of  $M$ . Thus we shall see that  $\tilde{M}$  does not simulate  $f$ , and we shall conclude that nor does  $M$ .

Let us now begin with the definition of the term ‘specialization’:

DEFINITION 2.4: Given the sets  $\mathcal{F}$  and  $\tilde{\mathcal{F}}$  of functions from  $\mathbb{P}$  to  $\Pi(\mathbb{P})$ . Let  $M$  be an  $\mathcal{F}$ -GCM<sub>0</sub> and let  $\tilde{M}$  be a  $\tilde{\mathcal{F}}$ -GCM<sub>0</sub>. We assume that the programs of  $M$  and  $\tilde{M}$  are the same up to the following exception:

Any statement  $\varphi_v = 'pi: \in g_v(pj);'$  occurring in  $M$  is replaced by  $\tilde{\varphi}_v = 'pi: \in \tilde{g}_v(pj);'$  in  $\tilde{M}$ , where  $g_v \in \mathcal{F}$  and  $\tilde{g}_v \in \tilde{\mathcal{F}}$  have the following property:  $(\forall Q \in \mathbb{P}) \tilde{g}_v(Q) \subseteq g_v(Q)$ . (I. e.,  $M$  takes its nondeterministic decisions within  $\tilde{g}_v(Q)$  instead of  $g_v(Q)$ ; hence  $\tilde{M}$  can choose among “fewer” points  $P_j$  than  $M$ .)

Then  $\tilde{M}$  is called a *specialization* of  $M$ . ■

In the next Lemma we want to realize that specializations indeed have something to do with the problem of simulation:

LEMMA 2.5: Let  $M$  be an  $\mathcal{F}$ -GCM<sub>0</sub> and  $\tilde{M}$  an  $\tilde{\mathcal{F}}$ -GCM<sub>0</sub>. We assume that  $\tilde{M}$  is a specialization of  $M$ . Then the following statements are true:

- (a) If  $M$  constructs a relation  $R \subseteq \mathbb{P} \times \mathbb{P}$  then there exists a relation  $\tilde{R} \subseteq R$  such that  $\text{def}(\tilde{R}) = \text{def}(R)$  and  $\tilde{R}$  is constructed by  $\tilde{M}$ .
- (b) If  $R$  is even a partial function, then  $R$  itself is constructed by  $\tilde{M}$ .
- (c) If  $M$  simulates a function  $f: \mathbb{P} \rightarrow \Pi(\mathbb{P})$  then also  $\tilde{M}$  does so.

*Proof:* Part (i) is proven as follows: According to Definition 1.5 we know that  $\tilde{M}$  constructs the relation  $\tilde{R} := \{ (P_1, Q) \mid \text{After input of } P_1, \tilde{M} \text{ cannot enter the state } E, \text{ and } Q \text{ can be output by } \tilde{M} \}$ . We now have to realize that  $\text{def}(\tilde{R}) = \text{def}(R)$  and that  $\tilde{R} \subseteq R$ . But both statements immediately follow from the fact that every nondeterministic decision of  $\tilde{M}$  can also be taken by  $M$ .

Part (ii) and Part (iii) are consequences of (i) and the Definitions 1.5 and 2.1. ■

With the help of this lemma we now prove our results about the impossibility to simulate a function  $f_2$  by an  $f_1$ -GCM<sub>0</sub>. The next two theorems deal

with the case that  $f_i(Q) = A_i \setminus \{Q\}$  where  $A_2$  is bounded and  $A_1$  is not. Note that our results are according to the common sense: It is not possible to find a point within the “small” bounded set  $A_2 \setminus \{Q\}$  if only the “large” unbounded set  $A_1 \setminus \{Q\}$  is available.

The next Theorem 2.6 is a special case of 2.7. Both proofs are based on the same ideas but that of 2.6 is simpler. Therefore, studying the special case helps to understand the more general proof.

**THEOREM 2.6:** *Given the following functions  $f_1, f_2: \mathbb{P} \rightarrow \Pi(\mathbb{P})$ :*

$$(\forall Q \in \mathbb{P}) f_1(Q) := G_x \setminus \{Q\} \text{ and } f_2(Q) := \bar{B}(0, 1) \setminus \{Q\}.$$

Then  $f_2$  cannot be simulated by any  $f_1$ -GCM<sub>0</sub>  $M$ .

*Proof:* Otherwise we construct the following specialization  $\tilde{M}$  of  $M$ : Let  $\tilde{f}_1: \mathbb{P} \rightarrow \Pi(\mathbb{P})$  be defined as  $Q = (x|y) \mapsto \{(x^2 + 1 | 0)\}$ . Then  $\tilde{f}_1(Q) \subseteq G_x \setminus \{Q\} = f_1(Q)$  for every  $Q \in \mathbb{P}$ . Therefore we indeed obtain a specialization  $\tilde{M}$  of  $M$  if we replaced every instruction ‘ $pi: \in f_1(pj)$ ,’ by ‘ $pi: \in \tilde{f}_1(pj)$ ,’.

Let us now study the behaviour of  $\tilde{M}$ . We can easily see that all of its steps can be described with the help of continuous functions. In particular, the nondeterministic operations of type (1) can be expressed with the help of root functions, and the instructions of type (\*) can only effect the computation of the continuous function  $(u|v) \mapsto (u^2 + 1 | 0)$ .

Consequently, we can find a continuous nested root function  $F: \mathbb{P} \rightarrow \mathbb{P}$  such that the following is true: For every input  $P_1$ ,  $\tilde{M}$  can output  $F(P_1)$  if taking appropriate nondeterministic decisions.

Note now that also  $\tilde{M}$  simulates  $f_2$  because of Lemma 2.5.(c). Then 2.2.(b) implies that

- (1) For every  $Q \in \mathbb{P}$ ,  $F(Q)$  must be in  $f_2(Q)$ .

Let us now apply our main trick. From (1) it follows that  $F(Q) \in \bar{B}(0, 1)$  for every  $Q$ . Hence  $F(\bar{B}(0, 1)) \subseteq \bar{B}(0, 1)$ . Since  $F$  is continuous, *Brouwer’s fixed point theorem* yields a fixed point  $Q^*$  of  $F$ . Consequently,

$$F(Q^*) = Q^* \notin \bar{B}(0, 1) \setminus \{Q^*\} = f_2(Q^*).$$

This is a contradiction to (1). Hence an  $f_1$ -GCM<sub>0</sub>  $M$  simulating  $f_2$  cannot exist. ■

We next treat the more general version of 2.6:

**THEOREM 2.7:** *Let  $A_1, A_2 \subseteq \mathbb{P}$  where  $A_2$  is bounded and  $A_1$  is not. Moreover, for  $i=1, 2$  let  $f_i: \mathbb{P} \rightarrow \Pi(\mathbb{P})$ ,  $Q \mapsto A_i \setminus \{Q\}$ . Then  $f_2$  cannot be simulated by any  $f_1$ -GCM<sub>0</sub>  $M$ .*

(Example:  $A_1 = \{(x|0) \mid x \in \mathbb{N}\}$ ,  $A_2 = \bar{B}(0, 1)$ .)

*Proof:* Obviously there exists a closed circular disk  $D_2 \supseteq A_2$ . Let now  $M$  be an  $f_1$ -GCM<sub>0</sub> simulating  $f_2$ .

We now shall apply almost the same ideas as in the previous proof. We shall create a particular specialization  $\tilde{M}$ ; if  $P_1 \in D_2$  is input, then  $\tilde{M}$  will be able to output  $F(P_1) \in A_2 \subseteq D_2$  where  $F$  is continuous. Finally we shall apply Brouwer's fixed point theorem.

Let us now start with the details of the proof. Let  $(\varphi_1 \dots \varphi_n)$  be the program of  $M$ ; let  $1 \leq v_1 < \dots < v_r < n$  be the indices of the type-(\*)-instructions of  $M$ .

We next create  $\tilde{M}$ . For this end we recursively modify the statements  $\varphi_{v_\rho} = 'p i_\rho : \in f_1(p j_\rho)'$ :

Let us first treat  $\rho=1$ . We define  $U^{(1)} \subseteq \mathbb{P}$  as the set of those points  $P_{j_1}$  which can be generated as follows: An arbitrary  $P_1 \in D_2$  is input, and  $\tilde{M}$  executes its first  $(v_1 - 1)$  steps. We next note that all previous nondeterministic statements are of type (1); each of them only allows a decision between two possibilities. Hence we can find *finitely* many nested root functions  $F_1, \dots, F_q: D_2 \rightarrow \mathbb{P}$  such that for every input  $P_1 \in D_2$ ,  $M$  can only create one of the points  $P_{j_1} = F_1(P_1), \dots, P_{j_1} = F_q(P_1)$ . Consequently,

$$(1) U^{(1)} = F_1(D_2) \cup \dots \cup F_q(D_2).$$

Since  $F_1, \dots, F_q$  are continuous and  $D_2$  is a compact set, we have

$$(2) U^{(1)} \text{ is bounded.}$$

Consequently there exists a point  $Q^{(1)} \in A_1 \setminus U^{(1)}$ . Then we define  $f^{(1)}: \mathbb{P} \rightarrow \Pi(\mathbb{P})$  as

$$Q \mapsto \left\{ \begin{array}{l} \{Q^{(1)}\} \text{ if } Q \in U^{(1)} \\ A_1 \setminus \{Q\} \text{ if } Q \notin U^{(1)} \end{array} \right\}.$$

Furthermore we replace  $\varphi_{v_1}$  by  $'p i_1 : \in f^{(1)}(p j_1)'$ .

Then it is obvious that for  $\rho' = 1$  the following statements are true:

(3) If  $P_1 \in D_2$  is input then the modified statement  $\varphi_{v_{\rho'}}$  is deterministic; only  $Q^{(\rho')}$  can be loaded into  $p i_{\rho'}$ .

(4)  $f^{(\rho')}(Q) \subseteq f_1(Q)$  for every  $Q \in \mathbb{P}$ . (This follows from  $Q^{(\rho')} \in A_1 \setminus U^{(\rho')}$ .)

We next have to modify  $\varphi_{v_\rho}$  ( $\rho > 1$ ). Let  $\varphi_{v_1}, \dots, \varphi_{v_{\rho-1}}$  be already altered with the help of the points  $Q^{(\rho')}$  and the functions  $f^{(\rho')}$  where  $\rho' = 1, \dots, \rho - 1$ ; we assume that for every  $\rho' < \rho$  the facts (3) and (4) are true.

We now define  $U^{(\rho)} \subseteq \mathbb{P}$  analogically to  $U^{(1)}$ : Let  $P_1 \in D_2$  be an arbitrary input of  $\tilde{M}$  and let  $\tilde{M}$  execute its first  $(v_\rho - 1)$  steps; then  $U^{(\rho)}$  is the set of all points  $P_j$  which can be generated in this way. It follows from (3) that the operations of type (1) are the only nondeterministic ones which have an influence on  $U^{(\rho)}$ . This implies that

(5)  $U^{(\rho)}$  has the structure described in (1) so that  $U^{(\rho)}$  is bounded.

Consequently we can find  $Q^{(\rho)} \in A_1 \setminus U^{(\rho)}$ ; thus we can define  $f^{(\rho)}$  in the same way as  $f^{(1)}$ , and the facts (3), (4) are true for  $\rho' = \rho$ , too.

Now the modification of the statements  $\varphi_{v_1}, \dots, \varphi_{v_r}$  is finished. We have obtained a  $\{f^{(1)}, \dots, f^{(r)}\}$ -GCM<sub>0</sub>  $\tilde{M}$  which is indeed a specialization of  $M$  because of (4).

According to Definition 2.1,  $M$  constructs a relation and must have an output statement  $\varphi_m = \text{'write}(pi)$ ;'. This statement was not modified and also occurs in the program of  $\tilde{M}$ . We now again apply the argumentation basing on (3). Thus we obtain finitely many nested root functions  $G_1, \dots, G_q: D_2 \rightarrow \mathbb{P}$  such that for every input  $Q \in D_2$ ,  $\tilde{M}$  can output the points  $G_1(Q), \dots, G_q(Q)$ .

Let us now consider  $G_1$ . It follows from Lemma 2.5.(c) that also  $\tilde{M}$  simulates  $f_2$ ; then Remark 2.2.(b) implies that

(6)  $G_1(Q)$  must be in  $f_2(Q)$  for every  $Q \in D_2$ .

Consequently,  $G_1(D_2) \subseteq A_2 \subseteq D_2$  where  $G_1$  is continuous. But then Brouwer's fixed point theorem yields a fixed point  $Q^* \in D_2$ . Hence,  $G_1(Q^*) = Q^* \notin A_2 \setminus \{Q^*\} = f_2(Q^*)$ . This is a contradiction to (6). Therefore an  $f_1$ -GCM<sub>0</sub> simulating  $f_2$  does not exist. ■

In the next theorem we want to disprove the relation ' $\{f_2\} \leq \{f_1\}$ ' in the following case:  $(\forall Q) f_i(Q) = A_i \setminus \{Q\}$ , where the open kernel of  $A_2$  is empty and that of  $A_1$  is not. At the first sight this result is obvious: It is difficult to find a point in a "thin" set  $A_2$  if only the "thick" set  $A_1$  is available. But in reality we have to make additional assumptions; they are commented on in Remark 2.9.

**THEOREM 2.8:** *Given  $A_1, A_2 \subseteq \mathbb{P}$  such that the open kernel of  $A_1$  is not empty. Moreover we assume that  $A_2$  is the disjoint union of countably many closed line-segments. (I.e. there are a countable set  $L$  and points  $U_l, V_l$  such that  $U_l, V_l \cap U_{\hat{l}}, V_{\hat{l}} = \emptyset$  for  $l \neq \hat{l}$  and  $A_2 = \bigcup_{l \in L} \overline{U_l, V_l}$ . It is possible that*

$\overline{U_i}, \overline{V_i} = \{U_i\} = \{V_i\}$  for some  $l$ .) Moreover, let  $f_i: \mathbb{P} \rightarrow \Pi(\mathbb{P})$ ,  $Q \mapsto A_i \setminus \{Q\}$  ( $i=1, 2$ ). Then  $f_2$  cannot be simulated with the help of any  $f_1$ -GCM<sub>0</sub>  $M$ .

(Example: We modify the example given immediately before the proof to 2.7: Let  $A_1 := \overline{B}(0, 1)$  and  $A_2 := \{(x|0) \mid x \in \mathbb{N}\}$ . Then  $A_2$  indeed consists of countably many (degenerate) closed line segments so that we can apply our theorem. Consequently,  $\{(x|0) \mid x \in \mathbb{N}\} \setminus \{Q\}$  is so “thin” that it cannot be replaced by the “thick” set  $\overline{B}(0, 1) \setminus \{Q\}$ , and vice versa,  $\overline{B}(0, 1) \setminus \{Q\}$  is so “small” that it cannot be simulated by the “large” set  $\{(x|0) \mid x \in \mathbb{N}\} \setminus \{Q\}$ .)

*Proof:* We start with the following definitions: For every  $l, l' \in L$  let  $S_{l, l'}$  be the closed line segment between  $U_l$  and  $V_{l'}$ . Let  $D_2 := \bigcup_{l, l' \in L} S_{l, l'}$ . Then  $D_2$  is the union of countably many line segments, and  $D_2$  is obviously connected. Moreover,  $D_2 \supseteq A_2 = \bigcup_{l \in L} S_{l, l}$ . We now assume again that there exists an  $f_1$ -GCM<sub>0</sub>  $M$  simulating  $f_2$ . Then we construct a particular specialization  $\tilde{M}$ .

For this end we do almost the same as in the proof to Theorem 2.7. We define the sets  $U^{(p)}$ , the points  $Q^{(p)}$  and the functions  $f^{(p)}$  in the same way as above. The only difficulty is the following: In the proof to Theorem 2.7, the points  $Q^{(p)}$  were chosen within  $A_1 \setminus U^{(p)}$ ; if we do the same here, we have to show that also in the present situation  $A_1 \setminus U^{(p)}$  is not empty. This can be seen as follows: We again apply the argumentation yielding (1) and (5) in the proof to 2.7; thus we may conclude that

$$U^{(p)} = F_1(D_2) \cup \dots \cup F_q(D_2), \tag{1}$$

where  $F_1, \dots, F_q: D_2 \rightarrow \mathbb{P}$  are nested root functions. Note now that  $D_2$  is the union of countably many line segments  $S_{l, l'}$ ; then  $U^{(p)}$  is the union of countably many images  $F_\sigma(S_{l, l'})$  ( $\sigma = 1, \dots, q, l, l' \in L$ ). Since every  $F_\sigma$  is a nested root function and every  $S_{l, l'}$  is a line segment, we may conclude that the open kernel of  $F_\sigma(S_{l, l'})$  is empty.

But then Baire’s category theorem says that the open kernel of the countable union  $U^{(p)}$  must also be empty. Since  $A_1$  has a non-empty open kernel, we can actually conclude the existence of a point  $Q^{(p)} \in A_1 \setminus U^{(p)}$ .

Now the construction of  $\tilde{M}$  is finished. In the same way as in the proof to Theorem 2.7 we obtain continuous functions  $G_1, \dots, G_q: D_2 \rightarrow A_2$  such that for every input  $P_1 \in D_2$ ,  $\tilde{M}$  can output the points  $G_1(P_1), \dots, G_q(P_1)$ . But the line segments  $S_{l, l}$  of  $A_2$  are pairwise disjoint, and  $D_2$  is connected. Consequently, there must be an  $l^*$  such that  $G_1(D_2) \subseteq S_{l^*, l^*}$ .

In particular, we have  $G_1(S_{I^*, I^*}) \subseteq S_{I^*, I^*}$ . But then the fixed point theorem of Brouwer yields a  $Q^* \in S_{I^*, I^*}$  such that  $G_1(Q^*) = Q^* \notin f_2(Q^*)$ ; this means that  $\tilde{M}$  does not in any case construct a point  $\in f_2(P_1)$  if  $P_1 = Q^*$  is input. Then Remark 2.2. (b) and Lemma 2.5. (c) imply that  $M$  does not simulate  $f_2$ . This is a contradiction to the assumption that  $M$  does simulate  $f_2$ . ■

*Remark 2.9:* Obviously we can weaken the assumption about the structure of  $A_2$  as follows:  $A_2$  is the disjoint union countably many sets which are *homeomorphic* to closed line segments. On the other hand, it is not possible to drop this condition: Let  $A_1 = \bar{B}(0, 1)$  and  $A_2 = S(0, 1)$  or  $A_2 = G_x$ ; in the first case,  $f_2$  can be simulated by the  $f_1$ - $GCM_0$  described in Remark 2.2. (c), and in the second case  $f_2$  is simulated by an  $f_1$ - $GCM_0$  constructing the function  $Q = (x | y) \rightarrow (x^2 + 1 | 0) \in G_x \setminus \{Q\}$ . ■

### CONCLUDING REMARKS

In this paper we presented and investigated the  $\mathcal{F}$ - $GCM_0$ . This is a geometrical register machine which can simulate the use of compass and ruler and nondeterministically choose auxiliary points within particular regions.

Our investigations were on the power of these machines: Theorem 1.7 was on the constructible functions. The result 2.3 dealt with a large class of equivalent extensions of the  $GCM_0$ . In the Theorems 2.6–2.8 we presented some general classes of pairs  $(f_1, f_2)$  such that  $f_2$  could not be simulated by any  $f_1$ - $GCM_0$ . These proofs were based on topological and fixed point theoretical facts.

It is obvious that a lot of similar problems arises from the plenty of further modifications of the  $GCM_0$ 's. E. g., we can

- treat generalized  $\mathcal{F}$ - $GCM_0$ 's according to Definition 1.3. (b).
- equip the  $\mathcal{F}$ - $GCM_0$ 's with the capability of conditional jumps,
- modify the drawing tools, e. g. define  $\mathcal{F}$ - $GCM_1$ 's basing on a rectangular ruler instead of compass and ruler.

### REFERENCES

1. D. HILBERT, *Grundlagen der Geometrie*. Teubner Studienbücher, 11th edition, 1972.
2. U. HUCKENBECK, *Geometrische Maschinenmodelle*. Ph. D. thesis, University at Würzburg, 1986.

3. U. HUCKENBECK, Geometrical Abstract Automata. *Proc. Workshop on Computational Geometry and its Applications (CG 88, Würzburg, March 1988)*, *Lect. Notes in Comp. Sci.* 333, p. 217-231.
4. U. HUCKENBECK, Euclidian Geometry in Terms of Automata Theory, *Theoretical Computer Science*, vol. 68, 1989, p. 71-87.
5. U. HUCKENBECK, On Fixed Points of Rational Functions with Values on a Circle. *Bolletino U.M.I., Sez. A*, to appear.
6. F. P. PREPARATA and M.I. SHAMOS, *Computational Geometry, an Introduction*, Springer, 1985.
7. P. SCHREIBER, *Grundlagen der konstruktiven Geometrie*, VEB Verlag der Wissenschaften, Berlin, 1984.
8. M. I. SHAMOS, Geometric Complexity. *Proc. 7th ACM Symp. on the Theory of Computing*, May 1975, p. 224-233.
9. H. TIETZE, Über die Konstruierbarkeit mit Lineal und Zirkel, *Sitzungsbericht der kaiserlichen Akademie der Wissenschaften, mathemat.-naturwissenschaftl. Klasse 118, Abteilung II a*, 1909, p. 735-757.