

ANNALI DELLA  
SCUOLA NORMALE SUPERIORE DI PISA  
*Classe di Scienze*

KOK SENG CHUA

**Absolute gradient bound for surfaces of constant mean curvature**

*Annali della Scuola Normale Superiore di Pisa, Classe di Scienze 4<sup>e</sup> série*, tome 21,  
n° 1 (1994), p. 1-9

[http://www.numdam.org/item?id=ASNSP\\_1994\\_4\\_21\\_1\\_1\\_0](http://www.numdam.org/item?id=ASNSP_1994_4_21_1_1_0)

© Scuola Normale Superiore, Pisa, 1994, tous droits réservés.

L'accès aux archives de la revue « *Annali della Scuola Normale Superiore di Pisa, Classe di Scienze* » (<http://www.sns.it/it/edizioni/riviste/annaliscienze/>) implique l'accord avec les conditions générales d'utilisation (<http://www.numdam.org/conditions>). Toute utilisation commerciale ou impression systématique est constitutive d'une infraction pénale. Toute copie ou impression de ce fichier doit contenir la présente mention de copyright.

NUMDAM

Article numérisé dans le cadre du programme  
Numérisation de documents anciens mathématiques  
<http://www.numdam.org/>

# Absolute Gradient Bound for Surfaces of Constant Mean Curvature

KOK SENG CHUA

In 1977, Finn and Giusti proved in [5] the following theorem:

*There exists an absolute constant  $R_0 = 0.565406\dots$  and a nondecreasing function  $A(R)$  for  $R_0 < R \leq 1$  with  $A(1) = 0$ , such that if  $u(x, y)$  is a solution of*

$$\operatorname{div} Tu = 2, \quad Tu = \frac{Du}{\sqrt{1 + |Du|^2}}, \quad Du = (u_x, u_y)$$

*in a disc of radius  $R$  centered at 0, then  $|Du(0)| \leq A(R)$ .*

The main idea in [5] is a comparison principle, and the  $A(R)$  occurring in the above theorem is the gradient at certain points of one of a family of universal comparison surfaces: the moon surfaces whose existence has been established in [4]. The  $A(R)$ 's are however not explicitly known. In this paper we employ similar ideas of comparison as in [5] together with a family of explicitly known comparison surfaces: a family of surfaces discovered by Delaunay in [2] with the aim of giving an upper bound for  $A(R)$ . This gives us an explicit gradient bound in the Finn-Giusti theorem above.

In section 1 we introduce the moon surfaces and study the geometry of a particular moon domain which is essential later. In section 2 we consider the Delaunay surfaces: a family of explicitly known comparison surfaces of constant mean curvature. We are particularly interested in their gradients, which can be computed explicitly. In section 3 we obtain our main result: a form of the Finn-Giusti theorem with explicit gradient bound.

## 1. - Moon Surfaces and the Finn-Giusti Theorem

In this section we consider the moon surface introduced in [5], we study

Pervenuto alla Redazione il 15 Novembre 1990 e in forma definitiva il 21 Luglio 1992.

the geometry of a particular moon domain and we fix the notations. We will also recall the main result in [5] in a more explicit way.

For  $1/2 < R < 1$  the moon domain  $D_R$  is the domain shown in Fig. 1, where  $\Sigma^+$  and  $\Sigma^-$  are circular arcs of radius  $R$  and  $1/2$  respectively. The moon surface  $M_R$  is a formal solution over  $D_R$  of

$$\operatorname{div} Tu = 2, \quad Tu = \frac{Du}{\sqrt{1 + |Du|^2}}$$

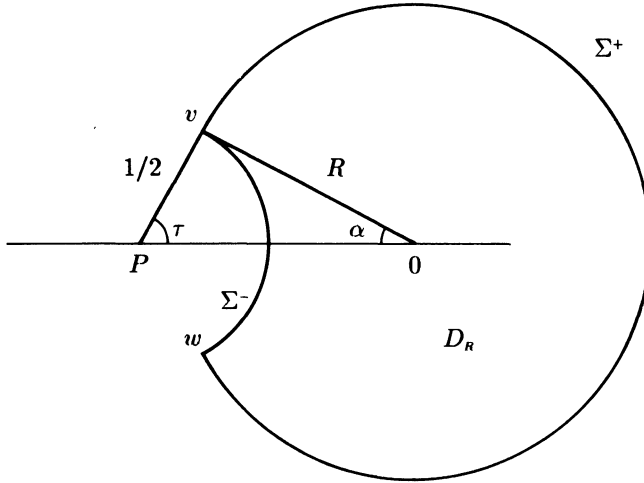

Figure 1: The moon domain  $D_R$

such that

$$\nu \cdot Tu = +1 \text{ on } \Sigma^+, \quad \nu \cdot Tu = -1 \text{ on } \Sigma^-$$

where  $\nu$  is the unit exterior normal.

Integrating the above, we obtain

$$(1.1) \quad \Phi[D, R] = |\Sigma^-| - |\Sigma^+| + 2|D_R| = 0$$

and this determines the center of  $\Sigma^-$  uniquely on the center line.

We remark that the moon surfaces are all symmetric about the symmetry line, as follows from uniqueness (see [3]). We refer the reader to [4] for existence and construction of the moon surfaces.

We will be mainly concerned with a particular moon surface corresponding to  $R = R_0 = 0.565406\dots$  when  $\Sigma^-$  passes through the center 0 of  $\Sigma^+$ . We refer

the reader to [5] for the determination of the value of  $R_0$ . We will denote this particular moon surface by  $M$  and the corresponding moon domain by  $D$ . We will also denote by  $x$  a point at distance  $x$  to the right of 0 on the symmetry line of  $D$  (see Fig. 2). We define

$$\lambda(x) = \min_{0 < y \leq x} |DM(y)|.$$

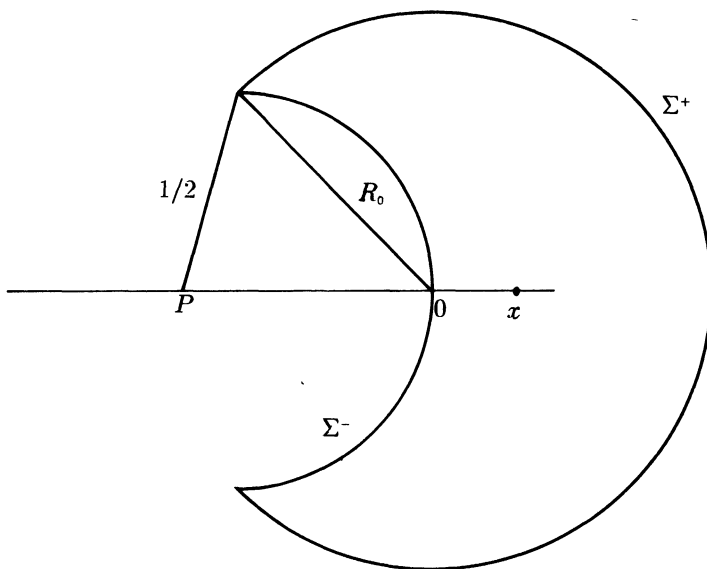

Figure 2: The moon domain  $D = D_{R_0}$

With these notations, the arguments in [5] give:

**THEOREM 1.1** (Finn-Giusti). *Let  $R > R_0 = 0.564606\dots$  and  $u(x, y)$  be a  $C^2$  solution of*

$$\operatorname{div} Tu = 2, \quad Tu = \frac{Du}{\sqrt{1 + |Du|^2}}$$

*in the disc  $B_R$  of radius  $R$  centered at 0; then*

$$|Du(0)| \leq \lambda(R - R_0).$$

We strongly urge the reader to read [5] for a proof of the above theorem as it also contains the main idea of this paper in a different context.

The main purpose of this paper is to give an explicit upper bound for the above function  $\lambda$ , thus giving an explicit gradient bound in the Finn-Giusti theorem.

Now we discuss some geometric properties of the moon domain  $D$  (see Fig. 3) which we will require later.

LEMMA 1.2. *Let  $R \in PO$  be such that  $\angle VRP = \angle VPR = \tau$  (see Fig. 3); then*

$$d = |PR| = 1 - 2R_0^2 = 0.36063158\dots$$

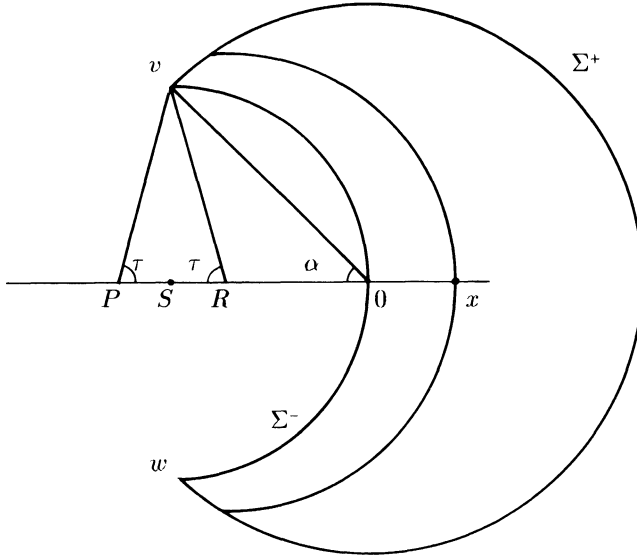

Figure 3: Illustration of Lemmas 1.2 and 1.3

PROOF. We first note that  $\tau > \alpha$  since  $R_0 > 1/2$ , so that the point  $R$  exists between  $P$  and  $O$ . Clearly  $d = |PR| = \cos \tau = 1 - 2R_0^2$  by the cosine rule applied to the isosceles triangle  $VRP$ . ■

LEMMA 1.3. *If  $0 < x < d$  the circle of radius  $1/2$  centered at the point  $S$  at distance  $x$  to the right of  $P$  intersects the boundary of  $D$  in  $\Sigma^+$  (see Fig. 3).*

PROOF. This is clear for small positive  $x$ . As  $x$  increases, the circle intersects  $\Sigma^-$  when it passes through the points  $V$  and  $w$ . This occurs when the center is at  $R$  with  $VR = 1/2$  and  $PR = d$ . ■

For  $0 < c \leq 1/2$  we will denote by  $A_c$  the annulus  $1/2 - c < r < 1/2 + c$ .

The key fact on which our method is based is the following:

LEMMA 1.4. *Let  $0 < x < d$  and  $c = 1/2 - \sqrt{1/4 - x(d-x)}$ . The annulus  $A_c$  placed over  $D$  so that its center  $S$  is at distance  $x$  to the right of  $P$  intersects the boundary of  $D$  entirely in  $\Sigma^+$  (see Fig. 4).*

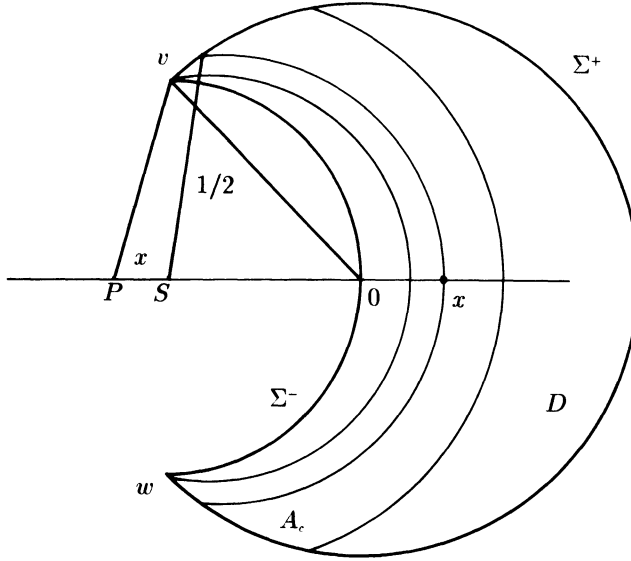

Figure 4: Illustration of Lemma 1.4

PROOF. By Lemma 1.3 the circle of radius  $1/2$  does not intersect  $\Sigma^-$  so that the configuration is possible for some  $A_c$ . The largest possible such  $A_c$  must have inner boundary passing through  $V$  and  $W$ . The inner radius is therefore determined from the triangle  $PSV$  by the cosine rule, and it is  $\sqrt{1/4 + x^2 - xd}$ . ■

## 2. - Delaunay Surfaces: the Unduloids

In this section we construct an explicitly known family of surfaces of constant mean curvature which will serve as comparison surfaces to give us

explicit upper bounds for  $\lambda$ . These surfaces were discovered by Delaunay in 1841.

Delaunay in [2] showed that if one rolls an ellipse along a line  $L$ , then each focus generates a curve which when rotated about  $L$  gives a rotationally symmetric surface of constant mean curvature  $H$ . If the center of the ellipse is at distance  $1/2$  from  $L$  then  $H = 1$ . We consider a single period as shown in Fig. 5.

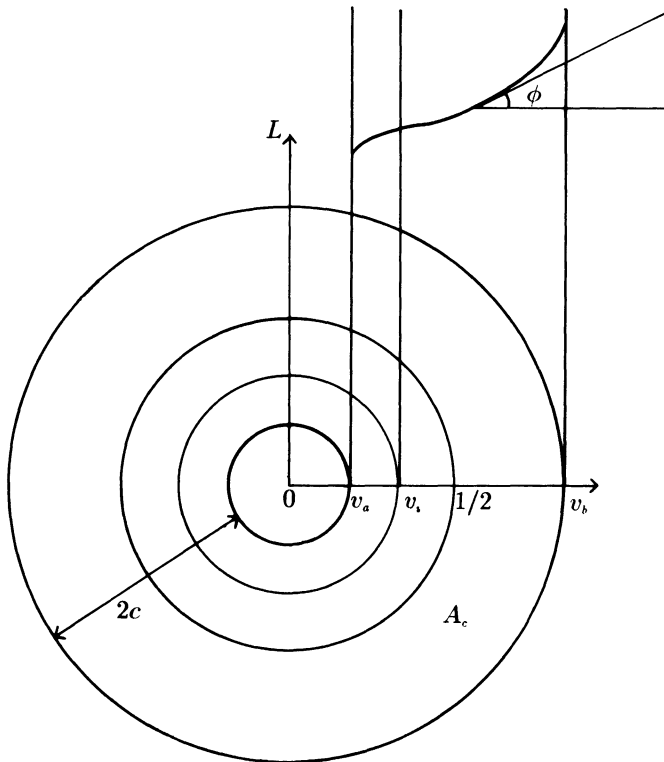

Figure 5: Delaunay surfaces

The defining height function then satisfies:

$$\operatorname{div} T\mathbf{u} = 2$$

on a circular annulus  $A_c : 1/2 - c < r < 1/2 + c$  and it points vertically upwards on the outer curve  $r = r_b = 1/2 + c$  and vertically downwards on the inner curve  $r = r_a = 1/2 - c$  ( $0 \leq c \leq 1/2$ ). As  $c$  tends to 0 this surface tends to a finite piece of a vertical cylinder, while as  $c$  tends to  $1/2$  it approaches a lower unit hemisphere.

If  $\phi$  is the angle of inclination, we have analytically

$$\frac{\sin \phi}{r} + (\sin \phi)_r = 2$$

which gives

$$(r \sin \phi)_r = 2r.$$

This equation admits a first integral

$$r^2 - r \sin \phi + (1/4 - c^2) = 0.$$

Thus  $r_a = 1/2 - c$ ,  $r_b = 1/2 + c$  and

$$r = \frac{1}{2} (\sin \phi \pm \sqrt{4c^2 - \cos^2 \phi});$$

the positive sign holds when  $r$  exceeds the inflexion  $(r_i, \phi_i)$ , where

$$r_i = \frac{1}{2} \sqrt{1 - 4c^2} = \sqrt{r_a r_b} < 1/2, \quad \cos \phi_i = 2c.$$

If  $r < r_i$  the negative sign holds. The inclination achieves a minimum at  $r_i$ . We have

$$m_c = \tan \phi_i = \frac{\sqrt{1 - 4c^2}}{2c}.$$

We have thus shown:

**LEMMA 2.1.** *For each  $c$  with  $0 < c < 1/2$  there exists a rotationally symmetric surface  $U_c$  of constant mean curvature 1 defined over an annular region  $A_c : 1/2 - c < r < 1/2 + c$  with outward-pointing gradient. The minimum of this gradient is attained at  $r_i < 1/2$  from the center, and it is*

$$m_c = |DU_c(r_i)| = \frac{\sqrt{1 - 4c^2}}{2c}.$$

We note that  $m_c$  decreases monotonically from infinity to 0 as  $c$  increases from 0 to  $1/2$ .



### 3. - An Explicit Gradient Bound

In this section we obtain an explicit form of the Finn-Giusti theorem. The main idea is that we are able to give an explicit upper bound for the function  $\lambda$  in Theorem 1.1 by comparing the moon surface  $M$  with the Delaunay surface  $U_c$  for a suitable value of  $c$  and then applying essentially the same arguments as in Lemma I.1 of [5]. More precisely, we have the following:

**THEOREM 3.1.** *Let  $0 < x < d = 0.3606\dots$ ,  $c = 1/2 - \sqrt{1/4 - x(d-x)}$ . Then*

$$\lambda(x) \leq m_c = \frac{\sqrt{(1-4c^2)}}{2c}.$$

**PROOF.** By Lemma 1.4, for the given values of  $x$  and  $c$ , one can place  $A_c$  over  $D$  symmetrically in such a way that the intersection of  $A_c$  and  $D$  does not meet  $\Sigma^-$  (see Fig. 4). If  $\lambda(x) = 0$  there is nothing to prove. Otherwise, the symmetry of  $M$  and the fact that it points vertically downwards as it approaches  $\Sigma^-$  implies that the gradient  $DM(y)$  must point to the right (in the same direction as  $DU_c$ ) for  $0 < y \leq x$ . Let  $T$  be the point of  $D$  corresponding to the point  $r_i$  of  $A_c$ . It suffices to prove that  $|DM(T)| \leq m_c$  since  $T$  comes before  $x$  along the symmetry line (recall the definition of  $\lambda$ ).

If, by contradiction,  $|DM(T)| > m_c$ , the intermediate value theorem implies that there exists a point  $z$  on the symmetry line such that  $DM(z) = DU_c(z)$  (recall that  $|DU_c|$  is infinite on the inner radius). Now we apply the same argument as in Lemma I.1 of [5] to obtain a contradiction. We note that  $M$  approaches a finite limit for any approach to  $\Sigma^+$  (see [4]) so that the function  $\eta$  used in the proof of Lemma I.1 of [5] can be defined. It is not difficult to show that the arguments of [5] can be carried out, and we have a contradiction. ■

**COROLLARY 3.2.** *Let  $x \geq \frac{d}{2} = 0.1803\dots$ ,  $c_0 = \frac{1 - \sqrt{1-d^2}}{2}$ . Then:*

$$\lambda(x) \leq m_{c_0} = 14.8297\dots$$

**PROOF.** Since  $m_c$  is decreasing in  $c$ , we maximise  $c$  and it is easily seen that this occurs at  $c = c_0$  corresponding to  $x = d/2$ . Since  $\lambda$  is decreasing we have, for  $x \geq d/2$ ,

$$\lambda(x) \leq \lambda\left(\frac{d}{2}\right) = m_{c_0} = 14.8297\dots \quad \blacksquare$$

We now combine Theorem 3.1, Corollary 3.2 and Theorem 1.1 to obtain our main result:

**THEOREM 3.3.** *Let  $R > R_0 = 0.565406\dots$  and  $u(x, y)$  be a  $C^2$  solution of  $\operatorname{div} Tu = 2$  in a disc of radius  $R$  centered at 0.*

If  $R \geq R_0 + d/2 = 0.7457\dots$ , then  $|Du(0)| \leq 14.8297\dots$   
 Otherwise let  $x = R - R_0$  ( $0 < x < d/2$ ) and set  $c = 1/2 - \sqrt{1/4 - x(d-x)}$ ;  
 then:

$$|Du(0)| \leq \frac{\sqrt{1-4c^2}}{2c}.$$

REMARKS. It is possible to obtain a slightly better result than that stated above since we know exactly the point of minimum gradient of the Delaunay surfaces. However, even in the improved form, we are not able to obtain the sharp bound which would imply that  $Du(0)$  vanishes as  $R$  tends to 1. We have thus preferred the above theorem which is simpler to state. The sharp bound would be obtained if one could prove that  $DM(x)$  vanishes at some point; but unfortunately we have not been able to do this. Our main contribution is that an explicit gradient bound in the Finn-Giusti theorem as given above is possible.

## REFERENCES

- [1] R. COURANT - D. HILBERT, *Methods of Mathematical Physics*, Vol. II. Interscience Publishers, New York, 1962.
- [2] C.E. DELAUNAY, *Sur la surface de revolution dont la courbure moyenne est constante*. J. Math. Pures Appl. **6** (1841), 409-415.
- [3] R. FINN, *Equilibrium Capillary Surface*. Springer-Verlag, New York, 1986.
- [4] R. FINN, *Moon surfaces and boundary behaviour of Capillary surfaces for perfect wetting and non wetting*. Proc. London Math. Soc. **57** (1988), 542-576.
- [5] R. FINN - E. GIUSTI, *On nonparametric surfaces of constant mean curvature*. Ann. Scuola Norm. Sup. Pisa **4** (1977), 13-31.

§:

German Singapore Institute  
 10 Science Center Road  
 Jurong  
 Singapore 2260