



ANNALES

DE

L'INSTITUT FOURIER

Philippe DI FRANCESCO, Paul ZINN-JUSTIN & Jean-Bernard ZUBER

Determinant formulae for some tiling problems and application to fully packed loops

Tome 55, n° 6 (2005), p. 2025-2050.

http://aif.cedram.org/item?id=AIF_2005__55_6_2025_0

© Association des Annales de l'institut Fourier, 2005, tous droits réservés.

L'accès aux articles de la revue « Annales de l'institut Fourier » (<http://aif.cedram.org/>), implique l'accord avec les conditions générales d'utilisation (<http://aif.cedram.org/legal/>). Toute reproduction en tout ou partie cet article sous quelque forme que ce soit pour tout usage autre que l'utilisation à fin strictement personnelle du copiste est constitutive d'une infraction pénale. Toute copie ou impression de ce fichier doit contenir la présente mention de copyright.

cedram

Article mis en ligne dans le cadre du
Centre de diffusion des revues académiques de mathématiques
<http://www.cedram.org/>

DETERMINANT FORMULAE FOR SOME TILING PROBLEMS AND APPLICATION TO FULLY PACKED LOOPS

by Philippe Di FRANCESCO, Paul ZINN-JUSTIN
& Jean-Bernard ZUBER

1. Introduction.

Determinants appear naturally in physics when one studies systems of free fermions: their wave functions (Slater wave function), as well as their grand canonical partition function, can be expressed as determinants. These statements have exact discrete counterparts. In particular, discrete dynamics can be formulated in terms of transfer matrices (instead of a Hamiltonian): these are familiar objects of statistical mechanics, which from a combinatorial point of view simply count the number of ways to go from a given initial configuration to a given final configuration. Here we are more specifically interested in models on two-dimensional lattices, in which the role of free fermions is played by non-intersecting paths; the analogous determinantal expressions can then be derived from the so-called Lindström-Gessel-Viennot (LGV) formula [12]. In this paper we intend to show how these determinantal techniques can be applied to some combinatorial problems, which all amount to the enumeration of certain types of rhombus tilings.

The methods we present here are fairly general and make use of various standard combinatorial objects. Young diagrams appear as a way to encode locations of paths crossing a given straight line; furthermore, the determinants involved often turn out to be Schur functions $s_Y(x)$ where,

Keywords: Tilings, alternating sign matrices, fully packed loops.
Math. classification: 05A19, 52C20, 82B20.

beside the Young diagram Y , appears the set of parameters $x = \{x_1, x_2, \dots\}$ which encodes the dynamics (here we are mostly concerned with simple counting, in which case $x_i = 1$). Also note that in the context of free fermions, Schur functions are natural building blocks for tau-functions of classical integrable hierarchies, see for example [1] for such a connection and further relations to matrix integrals.

The paper is organized as follows. In Section 2, we introduce the basic methods and tools which are required for our computations — the LGV formula, and the definition of the elementary transfer matrices from which all can be built — and revisit as an example the MacMahon formula. In Section 3, we provide some further examples of enumeration of rhombus tilings of various domains. In Section 4, we show how similar considerations also enable us to count fully packed loop (FPL) configurations with given connectivities and various symmetries. We conclude in Section 5 with some open issues, including a discussion of the asymptotic enumeration of FPL configurations.

2. Basic ingredients: corner transfer matrices and the LGV formula.

2.1. The LGV formula.

Here and in the following we consider lattice paths whose oriented steps connect nearest neighboring vertices of the two-dimensional integer lattice \mathbb{Z}^2 , and with only two directions allowed say along the vectors $(-1, 0)$ and $(0, 1)$. The LGV formula allows to express the number $\mathcal{P}(\{S\}, \{E\})$ of configurations of n non-intersecting lattice paths with, say, starting points S_1, S_2, \dots, S_n and endpoints E_1, E_2, \dots, E_n in \mathbb{Z}^2 , as the determinant of the matrix whose element (i, j) is the number $\mathcal{P}(S_i, E_j)$ of lattice paths from S_i to E_j , namely

$$(2.1) \quad \mathcal{P}(\{S\}, \{E\}) = \det \left(\mathcal{P}(S_i, E_j) \right)_{1 \leq i, j \leq N}.$$

For reasons that will become obvious later on, the matrix with entries $\mathcal{P}(S_i, E_j)$ will be called *transfer matrix* for the corresponding path counting problem.

2.2. The matrices W and T.

In this note we will mainly be dealing with lattice paths with starting and endpoints occupying consecutive positions along two lines

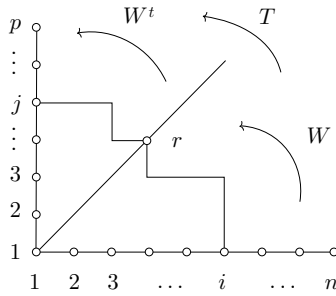

Figure 1. The transfer matrix T is expressed as a product WW^t .

that intersect. The most basic situations are depicted in Fig. 1. The most fundamental situation is that of (ordered) starting points $S_a = (i_a, 1)$, $a = 1, 2, \dots, N$, and endpoints $E_a = (r_a, r_a)$, $a = 1, 2, \dots, N$, namely with paths across a corner of angle 45° . The corresponding “corner” transfer matrix W has the entries

$$(2.2) \quad W_{i,r} \equiv \mathcal{P}((i, 1), (r, r)) = \binom{i-1}{r-1}$$

expressing that $r - 1$ vertical steps must be chosen among a total of $i - 1$. The action of W is represented in the lower corner of Fig. 1. The LGV formula allows us to write

$$(2.3) \quad \mathcal{P}(\{(i_a, 1)\}_{a=1,\dots,N}, \{(r_b, r_b)\}_{b=1,\dots,N}) = \det(W_{i_a, r_b})_{1 \leq a, b \leq N}.$$

Upon reflecting the picture and exchanging the roles of starting and endpoints, we easily find that W^t is the corner transfer matrix for the situation with starting points (r_a, r_a) and endpoints $(1, i_b)$. We deduce that the corner transfer matrix for the situation $S_a = (i_a, 1)$ and $E_b = (1, j_b)$ is nothing else than $T = WW^t$. We easily find that

$$(2.4) \quad T_{i,j} \equiv \mathcal{P}((i, 1), (1, j)) = \sum_{r \geq 1} W_{i,r} W_{j,r} = \binom{i+j-2}{i-1}$$

which eventually expresses that $i - 1$ horizontal steps must be taken among a total of $i + j - 2$. Similarly, the LGV formula gives

$$(2.5) \quad \mathcal{P}(\{(i_a, 1)\}_{a=1,\dots,N}, \{(1, j_b)\}_{b=1,\dots,N}) = \det(T_{i_a, j_b})_{1 \leq a, b \leq N}.$$

Note that in both (2.3) and (2.5) the result is simply the minor determinant corresponding to a specific choice of N rows and columns of the matrices W or T , taken of sufficiently large size.

2.3. Rhombus tiling of a hexagon: the MacMahon formula revisited.

As a first application of the above, let us evaluate the total number of rhombus tilings of a hexagon of size $a \times b \times c$, using the three elementary rhombi of size 1×1 .

The standard approach consists of introducing so-called De Bruijn lines that follow chains of consecutive rhombi of two of the three types. In Fig. 2, we have represented the a De Bruijn lines connecting consecutive points along the two sides of length a of the hexagon.

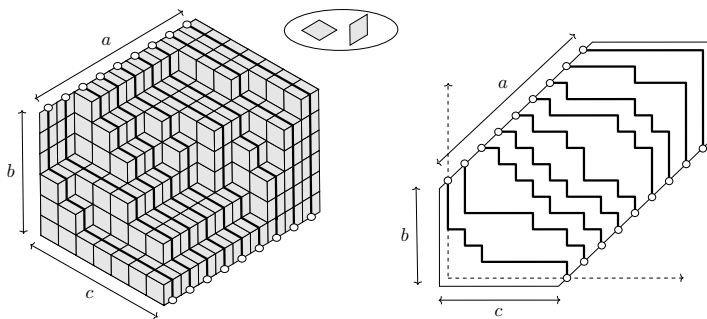

Figure 2. A sample rhombus tiling of a hexagon of size $a \times b \times c$ (left). We have indicated in heavy lines the De Bruijn lines following the two types of rhombi shown in the oval. We have deformed them so as to obtain a set of a non-intersecting lattice paths (right).

Upon slightly deforming the rhombi, as indicated in Fig. 2, these lines form a set of a non-intersecting lattice paths, with starting points $S_i = (c + i - 1, i)$, $i = 1, 2, \dots, a$ and endpoints $E_j = (j, b + j - 1)$, $j = 1, 2, \dots, a$. Moreover, rhombus tilings of the hexagon are in bijection with such non-intersecting lattice path configurations. The total number of such configurations reads, according to the LGV formula

$$(2.6) \quad N(a, b, c) = \det(H_{b,c}(a)_{i,j})_{1 \leq i, j \leq a}$$

where we have introduced the “parallel” transfer matrix $H_{b,c}$ of size $a \times a$, with entries

$$(2.7) \quad H_{b,c}(a)_{i,j} = \binom{b+c}{b+j-i}.$$

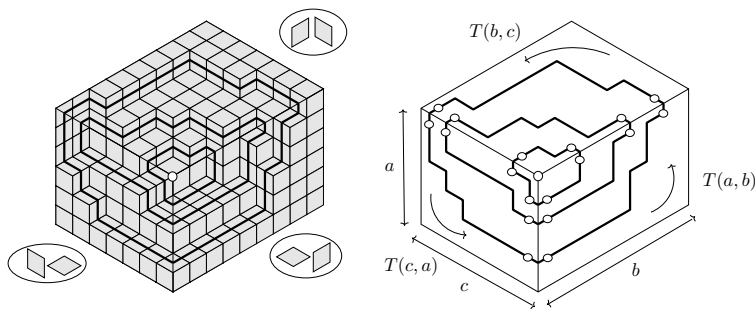

Figure 3. Using T to enumerate rhombus tilings of a hexagon with a given number of winding De Bruijn loops. The first picture shows a sample rhombus tiling, and its decomposition into three parallelograms. In each parallelogram, the De Bruijn lines follow sequences of the two rhombi displayed in the ovals. In the second picture, we only retain the De Bruijn lines: within each parallelogram, these are clearly generated by the corner transfer matrix T with the appropriate shape.

Note that Eq. (2.6) expresses $N(a, b, c)$ as the Schur function associated to the $b \times a$ rectangular Young diagram and to parameters $x_1 = \dots = x_{b+c} = 1$ (i.e. dimension as a $GL(b + c)$ representation). Similar occurrences will be discussed in more detail below.

By line and column manipulations, this determinant may be explicitly computed to yield the celebrated MacMahon formula

$$(2.8) \quad N(a, b, c) = \prod_{i=1}^a \prod_{j=1}^b \prod_{k=1}^c \frac{i + j + k - 1}{i + j + k - 2}.$$

We may alternatively decompose the hexagon into three parallelograms (there are exactly two ways of doing this, pick one), meeting at a “central point” (see Fig. 3). We now follow particular De Bruijn lines joining the inner edges of these parallelograms *without ever exiting* the hexagon. These are sequences of two of the three tiles, the pairs differing in the three parallelograms. These lines actually form loops that wind around the central point. Note finally that the problem of counting configurations of lines with fixed ends within each of the three parallelograms uses a corner transfer matrix T of appropriate size. In Fig. 3, we have denoted by $T(x, y)$ the rectangular matrix with entries (2.4), for $i = 1, 2, \dots, x$ and $j = 1, 2, \dots, y$. It is now easy to write the number $N_d(a, b, c)$ of configurations of exactly d non-intersecting loops winding around the central point:

$$\begin{aligned}
 (2.9) \quad N_d(a, b, c) &= \sum_{\substack{1 \leq a_1 < \dots < a_d \leq a \\ 1 \leq b_1 < \dots < b_d \leq b \\ 1 \leq c_1 < \dots < c_d \leq c}} \det_{1 \leq r, s \leq d} (T_{a_r, b_j} T_{b_j, c_k} T_{c_k, a_s}) \\
 &= \sum_{1 \leq a_1 < \dots < a_d \leq a} \det_{1 \leq r, s \leq d} ((T(a, b)T(b, c)T(c, a))_{a_r, a_s}) \\
 &= \det_{a \times a} (I + \mu T(a, b)T(b, c)T(c, a)) \Big|_{\mu^d}
 \end{aligned}$$

where the last line uses the decomposition formula for the determinant of the sum of two matrices in terms of their minors, and we have to extract the μ^d coefficient to get the sum over all diagonal minors of size $d \times d$. This gives a refinement of the MacMahon formula. We recover the total number of tilings of the hexagon by summing over d , or equivalently by taking $\mu = 1$ in the last determinant, namely

$$(2.10) \quad N(a, b, c) = \sum_{d=0}^{\min(a,b,c)} N_d(a, b, c) = \det(I + T(a, b)T(b, c)T(c, a)).$$

Note that the symmetry under the permutations of a, b, c is manifest here, as opposed to Eq. (2.6). In the case $a = b = c$, denoting $T(a) \equiv T(a, a)$, we have

$$\begin{aligned}
 (2.11) \quad N(a, a, a) &= \det(I + T(a))^3 \\
 &= \det(I + T(a)) \det(I + \omega T(a)) \det(I + \omega^2 T(a))
 \end{aligned}$$

where $\omega = e^{\frac{2}{3}i\pi}$. Nice formulas [6], [11] happen to be known for the characteristic polynomial of $T(a)$ precisely at sixth roots of unity, and allow for yet another expression for the MacMahon formula in a cube, via (2.11).

It is easy to relate this picture to the former, with a set of a standard De Bruijn lines connecting the opposite sides of length a in the hexagon. Indeed consider the intersection of the standard De Bruijn lines, as well of winding lines, with the line parallel to the a sides that goes through the center: the location of the lines is precisely the same to the right of the center, whereas it is complementary to the left. Therefore $N_d(a, b, c)$ also counts the tiling configurations *with exactly d of these lines passing to the right of the “center” of the hexagon*. This is also a consequence of the following relation between transfer matrices, pictorially proved in Fig. 4:

$$(2.12) \quad H_{b,c}(a) = W(b, a)^t P_b T(b, c) P_c W(c, a) + Z_b(a) Z_c(a)^t$$

in which the (i, j) entry of the first term counts the number of paths *passing to the right of the center* connecting the i -th entry point to the j -th exit

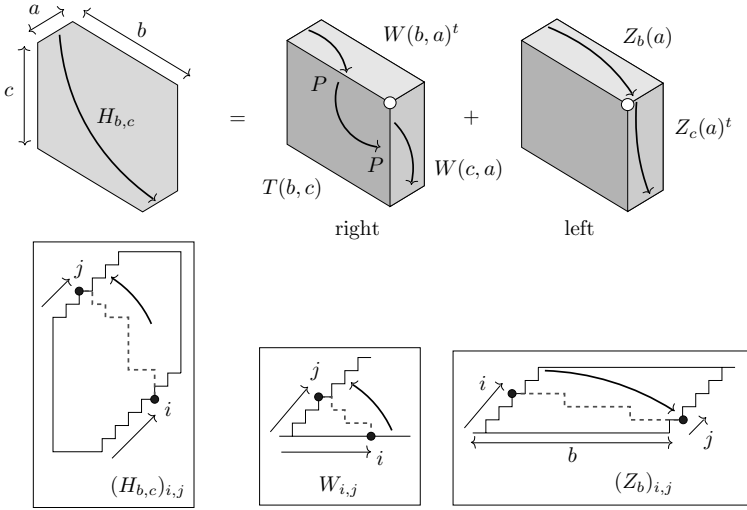

Figure 4. Decomposition of the transfer matrix $H_{b,c}(a)$ for De Bruijn lines of a $a \times b \times c$ hexagon which allows to keep track of paths passing to the left or right of the “center” (white dot). We give an explicit representation of the matrices W and Z_b .

one, while the second term yields the contribution of paths passing to the left of the center. In (2.12), as usual the argument corresponds to the size of the matrix (a) for a square $a \times a$ matrix, (a, b) for a rectangular $a \times b$ matrix), and the matrices have the following entries, see Fig. 4:

$$(2.13) \quad \begin{cases} (H_{b,c})_{ij} = \binom{b+c}{c+i-j}, & W_{ij} = \binom{i-1}{j-1}, \\ (P_b)_{ij} = \delta_{j,b+1-i}, & (Z_b)_{ij} = \binom{b}{i-j}. \end{cases}$$

Note that the matrix P induces a reflection, needed whenever passing from a corner to another one pointing in the opposite direction. We finally identify

$$(2.14) \quad \det_{a \times a} (I + \mu T(a, b)T(b, c)T(c, a)) = \det_{a \times a} (Z_b(a)Z_c(a)^t + \mu W(b, a)^t P_b T(b, c) P_c W(c, a))$$

by noticing that, after factoring out ZZ^t whose determinant is 1, the two corresponding matrices are conjugate of one-another.

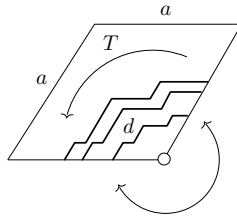

Figure 5. Computing the numbers of tilings of a lozenge of side a glued along two of its consecutive edges, and with exactly d loops winding around its conic singularity.

3. Rhombus tilings of various domains.

3.1. Lozenge with glued sides.

T may be used to compute the numbers $N_d^L(a)$ of tilings of a lozenge of side a glued along two of its consecutive edges (see Fig. 5), and on which exactly d De Bruijn loops wind around the tip of the cone. We simply have

$$(3.1) \quad N_d^L(a) = \det_{a \times a} (I + \mu T(a))|_{\mu^d}.$$

Disregarding the d dependence, we find the numbers

$$(3.2) \quad N^L(a) = \det_{a \times a} (I + T(a)) = \prod_{n=0}^{a-1} \frac{(3n+2)(3n)!n!}{(2n)!(2n+1)!}.$$

These read for $a = 1, 2, 3, \dots$

$$(3.3) \quad 2, 5, 20, 132, 1452, 26741, 826540, 42939620, \dots$$

This is by construction the number of cyclically symmetric plane partitions in a cube $a \times a \times a$, obtained by decomposing a regular hexagon of size $a \times a \times a$ into three identically tiled parallelograms, with suitable identifications of boundaries (see Section 4.3 for another interpretation of these numbers).

3.2. Half-hexagon with glued sides.

The corner transfer matrix W may be used to compute the numbers $N_d^{HH}(a)$ of tilings of a half-hexagon of side a glued along two of its cut edges (see Fig. 6), and on which exactly d De Bruijn loops wind

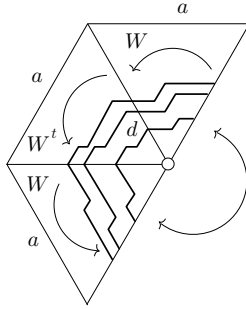

Figure 6. How to use the corner transfer matrices W and W^t to generate the rhombus tilings of a half-hexagon with glued sides. The gluing is indicated by the arrows. The half-hexagon is decomposed into three triangles, within which the De Bruijn lines are generated by W or W^t .

around the tip of the cone⁽¹⁾. We have

$$(3.4) \quad N_d^{HH}(a) = \det_{a \times a} (I + \mu W(a)W(a)^tW(a))|_{\mu^d}.$$

Disregarding the d dependence, we find the numbers

$$(3.5) \quad N^{HH}(a) = \det_{a \times a} (I + WW^tW) = \begin{cases} 2^n \left(\prod_{j=0}^{n-2} \frac{(4j+3)!(j+1)!j!}{(2j+2)!((2j+1)!)^2} \right)^2 \cdot \frac{(4n-1)!n!(n-1)!}{(2n)!((2n-1)!)^2} & \text{if } a = 2n, \\ 2^{n+1} \left(\prod_{j=0}^{n-1} \frac{(4j+3)!(j+1)!j!}{(2j+2)!((2j+1)!)^2} \right)^2 & \text{if } a = 2n+1. \end{cases}$$

These numbers read for $a = 1, 2, 3, \dots$

$$(3.6) \quad 2, 6, 36, 420, 9800, 4527650, 41835024, 7691667984 \dots$$

Remarkably, these turn out to match exactly *the total dimension of the homology of free 2-step nilpotent Lie algebras of rank a* [10] (cf. entry A078973 of the on-line encyclopedia of integer sequences [15]).

Let us give an explanation for this apparent coincidence, and present a determinant formula for the Poincaré polynomial of 2-step nilpotent Lie

⁽¹⁾ The present geometry was not considered before in the context of plane partitions. In particular the objects enumerated by $N_d^{HH}(a)$ are *not* the symmetric plane partitions introduced by MacMahon.

algebras of rank a . As in the case of the full hexagon, one can introduce the standard De Bruijn lines; here there are a lines which enter from the middle side of length a and come out from the side of length $2a$. Let us denote by $2a \geq n_1 > \dots > n_a > 0$ the locations of their endpoints. Then the LGV formula tells us that the number of such De Bruijn lines at fixed endpoints n_i is

$$(3.7) \quad N_{(n)}^{HH}(a) = \det \binom{a}{n_i - (a + 1 - j)}_{1 \leq i, j \leq a}.$$

Now the irreducible representations of $GL(a)$ are indexed by Young diagrams $Y = \{\lambda_1, \lambda_2, \dots, \lambda_a\}$ with λ_i boxes in the i -th row, and $\lambda_i \geq \lambda_{i+1} \geq 0$ for $i = 1, 2, \dots, a - 1$. The corresponding character, evaluated on the class of matrices with eigenvalues $x = \{x_1, x_2, \dots, x_a\}$ is the Schur function, expressed via the Jacobi-Trudi formula as

$$s_Y(x) = \det (h_{\lambda_i + j - i}(x))_{1 \leq i, j \leq a} = \det (h'_{\lambda'_i + j - i}(x))_{1 \leq i, j \leq a}$$

where $h_m(x)$ are the complete symmetric functions, generated by

$$\sum_{m \geq 0} h_m(x) t^m = \prod_{i=1}^a \frac{1}{1 - tx_i},$$

similarly $\sum_{m \geq 0} h'_m(x) t^m = \prod_{i=1}^a (1 + tx_i)$, and the λ'_i denote the λ 's of the transposed Young diagram Y^T (reflected w.r.t. the first diagonal). The dimension \dim_Y of the representation Y corresponds to the character of the identity class, with $x_1 = x_2 = \dots = 1$ (also denoted by $x = 1$). Explicitly,

$$(3.8) \quad \begin{aligned} \dim_Y = s_Y(1) &= \det \binom{a + \lambda_i + j - i - 1}{\lambda_i + j - i}_{1 \leq i, j \leq a} \\ &= \det \binom{a}{\lambda'_i + j - i}_{1 \leq i, j \leq a}. \end{aligned}$$

We recognize this dimension, provided we identify $n_i = \lambda'_i + a + 1 - i$, in Eq. (3.7). Finally, the gluing of the two half-sides means that in the summation over the endpoints n_i , we must only include those such that the corresponding diagram Y is invariant by transposition. We thus find

$$(3.9) \quad N^{HH}(a) = \sum_{Y=Y^T} \dim_Y$$

which is precisely the quantity calculated in [10], with the result (3.5).

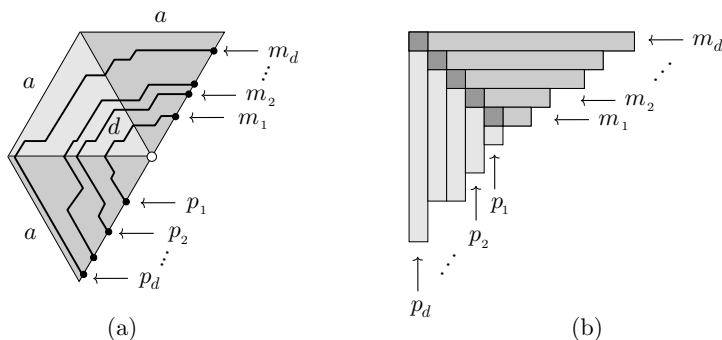

Figure 7. (a) Half-hexagon tilings with d De Bruijn lines having fixed endpoints, with positions m_1, m_2, \dots, m_d and p_1, p_2, \dots, p_d counted from the center. (b) The corresponding Young diagrams, with characteristics $(m;p)$ in Frobenius notation. Boxes are counted from and include the diagonal, from left to right (m 's) and top to bottom (p 's).

Note that the correspondence between the two approaches can be made for each term of the sum: indeed the endpoints of the standard lines and of the winding lines are clearly in one-to-one correspondence. If we record the positions of endpoints of the winding lines on the (cut) boundary, counted from the center, namely

$$(m; p) = \{m_1, \dots, m_d; p_1, \dots, p_d\},$$

$$1 \leq m_1 < m_2 < \dots < m_d \leq a \quad \text{from center to top and}$$

$$1 \leq p_1 < p_2 < \dots < p_d \leq a \quad \text{from center to bottom}$$

in the case of d winding lines, then the corresponding Young diagram Y is given by Fig. 7. Therefore, the total number of tiling configurations $N_{(m;p)}^{HH}(a)$ of the half-hexagon with fixed endpoints $(m; p)$ of De Bruijn lines is also the dimension of Y :

$$(3.10) \quad N_{(m;p)}^{HH}(a) = \det ((WW^tW)_{m_i, p_j})_{1 \leq i, j \leq d} = \dim_Y.$$

The Poincaré polynomial $P_a(u)$ generating the dimensions of the homology spaces of a 2-step nilpotent Lie algebra of rank a has been shown to read [10]

$$(3.11) \quad P_a(u) = \sum_{Y=Y^T} \dim_Y u^{|Y|}$$

where the sum extends over the self-transposed Young diagrams, namely those for which the two characteristics $(m;p)$ are equal, and where $|Y|$ denotes the total number of boxes in Y . Note that

$$|Y(m; m)| = \sum_{1 \leq i \leq d} (2m_i - 1).$$

Introducing the diagonal matrix θ with entries

$$(3.12) \quad \theta_{ij} = \delta_{ij} u^{2i-1}, \quad i, j = 1, 2, \dots, a$$

and using the relation (3.10), we get

$$(3.13) \quad P_a(u) = \det_{a \times a} (I + \theta W W^t W).$$

The first few such polynomials read

$$(3.14) \quad \left\{ \begin{array}{l} P_1(u) = 1 + u, \\ P_2(u) = 1 + 2u + 2u^3 + u^4, \\ P_3(u) = 1 + 3u + 8u^3 + 6u^4 + 6u^5 + 8u^6 + 3u^8 + u^9, \\ P_4(u) = 1 + 4u + 20u^3 + 20u^4 + 36u^5 + 64u^6 + 20u^7 + 90u^8 \\ \quad + 20u^9 + 64u^{10} + 36u^{11}, +20u^{12} + 20u^{13} + 4u^{15} + u^{16}, \\ P_5(u) = 1 + 5u + 40u^3 + 50u^4 + 126u^5 + 280u^6 + 160u^7 + 765u^8 \\ \quad + 245u^9 + 1248u^{10} + 720u^{11} + 1260u^{12} + 1260u^{13} \\ \quad + 720u^{14} + 1248u^{15} + 245u^{16} + 765u^{17} + 160u^{18} \\ \quad + 280u^{19} + 126u^{20} + 50u^{21} + 40u^{22} + 5u^{24} + u^{25}. \end{array} \right.$$

At $u = 1$, we recover the formula (3.5), which indeed counts the total dimension of the homology of a 2-step nilpotent Lie algebra of rank a .

3.3. Hexagon with a triangular central hole.

A variant of T may be used to generate the numbers $N_d(a, c+m, b, a + m, c, b + m)$ of tilings of a hexagon with an equilateral central triangle of side m removed (see Fig. 8), and with d loops winding around the hole. More precisely, let $T_m(a, b)$ denote the transfer matrix of rectangular size $a \times b$ with entries

$$(3.15) \quad (T_m)_{ij} = \binom{m + i + j - 2}{j - 1}$$

with $i = 1, 2, \dots, a, j = 1, 2, \dots, b$.

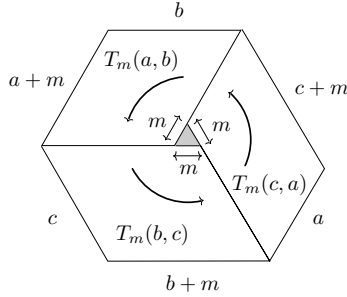

Figure 8. The transfer matrix $T_m(a, b)$ is used to generate tilings of a hexagon with a central triangular hole.

The configurations are then generated by

$$(3.16) \quad \det_{a \times a} (I + \mu T_m(a, b)T_m(b, c)T_m(c, a)) = \sum_{d=0}^{\min(a,b,c)} \mu^d N_d(a, c + m, b, a + m, c, b + m).$$

See [6] for explicit expressions of some of these determinants.

3.4. Hexagon with chopped-off corners.

We consider the tiling of a hexagon $a \times b \times c$ with three corners chopped off as indicated in Fig. 9, along line cuts at distances m, p, q from the central point, with $m \geq \max(a, b)$, $p \geq \max(b, c)$, and $q \geq \max(a, c)$, a case already studied in [5]. Let $N_d^{(m,p,q)}(a, b, c)$ denote the number of tilings of this domain with d winding lines. These are enumerated using a restricted version of T that incorporates a “ceiling” at a given height not to be crossed. By the reflection principle, the relevant truncation reads

$$(3.17) \quad T_{ij}^{(m)} = \binom{i + j - 2}{i - 1} - \binom{i + j - 2}{m}.$$

We denote by $T^{(m)}(a, b)$ the corresponding rectangular $a \times b$ matrix. With this definition, we have

$$(3.18) \quad \det_{a \times a} (I + \mu T^{(m)}(a, b)T^{(p)}(b, c)T^{(q)}(c, a))|_{\mu^a} = N_d^{(m,p,q)}(a, b, c).$$

Note that a half-corner transfer matrix can still be introduced, namely a matrix $W^{(m)}$ with entries

$$(3.19) \quad W_{ij}^{(m)} = \binom{i - 1}{j - 1} - \binom{i - 1}{m + 1 - j}$$

and such that $T^{(m)}(a, b) = W^{(m)}(a, c)W^{(m)}(b, c)^t$ for any $c \geq \frac{1}{2}m$.

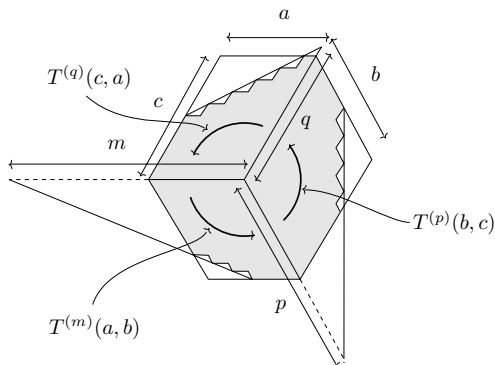

Figure 9. A hexagon of shape $a \times b \times c$ with three chopped off corners at distances m, p, q from the origin (central point). We have represented the relevant corner transfer matrix.

A particular case of (3.18) corresponds to tilings of a notched equilateral triangle, with $a = b = c$ and $m = p = q = a$.

We may easily treat the case of rectangular chopping as well, by suitably modifying T to incorporate the corresponding “broken ceiling” restriction indicated in Fig. 10. Let $N_d(a_1, a_2; b_1, b_2; c_1, c_2)$ denote the corresponding number of tilings with d winding loops. We have the transfer matrix

$$(3.20) \quad T(a_1, a_2; b_1, b_2) = \begin{pmatrix} T(a_1, b_1) & T_{0,b_1}(a_1, b_2) \\ T_{a_1,0}(a_2, b_1) & T(a_2, b_1)T(b_1, a_1)T(a_1, b_2) \end{pmatrix}$$

where $T_{m,p}(a, b)_{ij} = \binom{m+i+p+j-2}{m+i-1}$, $1 \leq i \leq a$, $1 \leq j \leq b$, and finally

$$(3.21) \quad N_d(a_1, a_2; b_1, b_2; c_1, c_2) = \det_{(a_1+a_2) \times (a_1+a_2)} (I + \mu T(a_1, a_2; b_1, b_2)T(b_1, b_2; c_1, c_2)T(c_1, c_2; a_1, a_2)) |_{\mu^d}.$$

4. Fully-packed loops and more tiling problems.

4.1. Fully-packed loops, alternating sign matrices and plane partitions.

The fully-packed loop (FPL) model plays a central role in the Razumov-Stroganov conjecture, which attracted a lot of attention recently. In short, the FPL model is a statistical model on a square grid of size $a \times a$ of the square lattice, in which edges may be occupied or not,

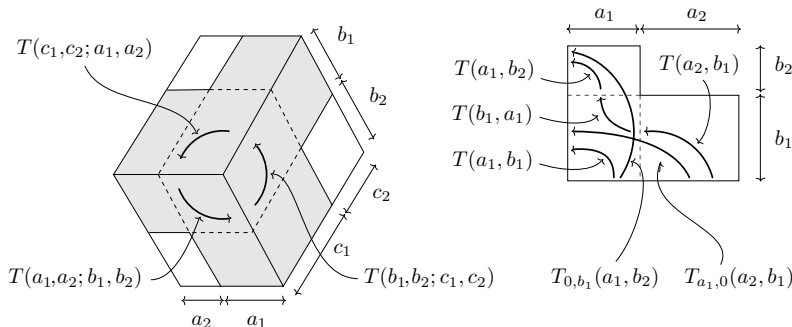

Figure 10. Tilings of a hexagon with removed parallelograms. The relevant transfer matrix T has a block decomposition according to the arrows.

and with the constraint that exactly two incident edges are occupied at each vertex. Moreover, one imposes alternating boundary conditions along the border of the grid, that every second edge at the exterior of and perpendicular to the boundary is occupied. These occupied external edges are labeled $1, 2, \dots, 2a$. The FPL configurations are in bijection with alternating sign matrices (ASM) of size $a \times a$, namely matrices with entries $\pm 1, 0$ only, such that $+1$ and -1 alternate and sum up to 1 along each row and column.

The Razumov-Stroganov conjecture involves refined FPL numbers, according to the connectivity of external edges. Indeed, from the definition of the model, the occupied external edges are connected by pairs via chains of consecutive occupied edges, forming lines (rather than loops) on the square grid, while closed loops may occupy some of the inner edges of the grid. To summarize these connectivities, one generally uses the language of link patterns, namely *planar* permutations $\pi \in S_{2a}$ with only 2-cycles indicating the connected edges. The Razumov-Stroganov conjecture relates the numbers of FPL with fixed connectivities to the groundstate vector of the $O(1)$ loop model [17], [2].

Rhombus tiling configurations of a hexagon are also called *plane partitions* (PP), as they may be interpreted as the view in perspective from the $(1, 1, 1)$ direction of a piling-up of unit cubes in the positive octant of the 3D lattice \mathbb{Z}^3 , with the constraint that gravity has the direction $-(1, 1, 1)$ and that only stable configurations are retained. The total number of FPL or ASM of size $a \times a$ matches that of so-called totally symmetric self-complementary plane partitions (TSSCPP) of size $2a \times 2a \times 2a$, namely

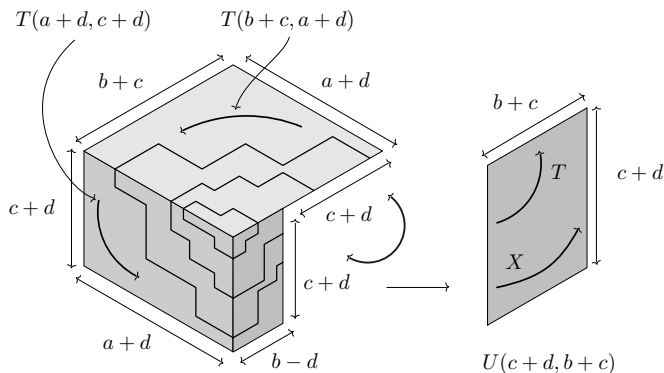

Figure 11. The domain whose rhombus tilings match the $N(a, b, c, d)$ FPL with four sets of nested lines a, b, c, d . It is a heptagonal domain with two sides glued, and with the indicated size. Moreover, it must have exactly d winding De Bruin loops (thick lines) crossing the gluing line. The transfer matrices are obtained by decomposing the domain into three parallelograms as indicated.

plane partitions being maximally symmetric, *i.e.* under rotations of $\frac{2}{3}\pi$ and reflections w.r.t. medians, as well as identical to their complement. This result is one of the keystones of modern combinatorics and is beautifully described in the book [3]. From this we simply retain that there should exist a natural bijection between the two sets of objects, still to be found to this day.

4.2. FPL with fixed sets of nested lines.

In parallel to the FPL-ASM-TSSCPP relation, there exist bijections between special FPL configurations and rhombus tilings of special domains. The simplest of these concerns the FPL of size $n \times n$ with three sets of nested lines, in numbers say a, b, c with $a + b + c = n$, namely with a link pattern that connects $2a$ external edges say $1, 2, \dots, 2a$ by symmetric pairs $(1, 2a)(2, 2a - 1), \dots, (a, a + 1)$, then the $2b$ next analogously and the $2c$ remaining analogously, thus forming three “bundles” of respectively a, b, c connecting lines. These were shown to be in bijection with the rhombus tilings of a hexagon of size $a \times b \times c$ [7], and henceforth are enumerated by the MacMahon formula (2.6).

This result was improved in [8] so as to include the case of four sets of nested lines, in numbers say a, b, c, d . The total number $N(a, b, c, d)$ of

such FPL matches that of rhombus tilings of the domain of Fig. 11, which have exactly d De Bruijn loops crossing the gluing line of length $c + d$. This decomposition allows one to write the number as

$$(4.1) \quad N(a, b, c, d) = \det_{(b+c) \times (b+c)} (I + T(b+c, a+d)T(a+d, c+d+e)U(c+d, b+c)) \Big|_{\mu^d}$$

where the transfer matrix $U(p, q)$ has the block form (see the right sketch of Fig. 11)

$$(4.2) \quad U(p, q) = \begin{pmatrix} T(p, q-p) & \mu X_{q-p}(p) \end{pmatrix}$$

where $(X_m)_{i,j} = \binom{m-1+i-j}{i-j}$.

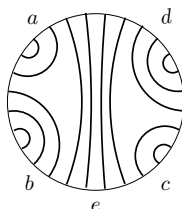

Figure 12. FPL configurations with four sets of nested arches separated into two subsets by a fifth one.

Finally, it is possible to extend this bijection to FPL with link patterns with five sets of nested lines as depicted on Fig. 12. These FPL are easily related to the rhombus tilings of the domain displayed in Fig. 13, which have exactly d De Bruijn loops going across the gluing line. The only difference with the case of four nested sets of lines is that we have introduced a branch cut of length e in the glued domain. The numbers $N(a, b | e | c, d)$ of desired FPL reads

$$(4.3) \quad N(a, b | e | c, d) = \det_{(b+c) \times (b+c)} (I + T(b+c, a+d)T(a+d, c+d+e)U^{(e)}(c+d+e, b+c)) \Big|_{\mu^d}$$

where the transfer matrix $U^{(e)}$ has the block form

$$(4.4) \quad U^{(e)}(p, q) = \begin{pmatrix} 0 & \\ T(p, q-p+e) & \mu X_{q-p+2e}(p-e) \end{pmatrix}$$

with a zero block of size $e \times (p - e)$. Note that all of the currently known numbers of FPL configurations with prescribed connectivities (for which a proof exists), as in [7], [8], [4], are special cases of our pattern $(a, b | e | c, d)$.

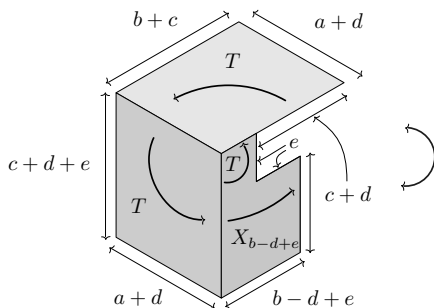

Figure 13. The domain whose rhombus tilings match the $N(a, b | e | c, d)$ FPL with a, b and c, d nested lines separated by e . The nonagon is glued along its edges of length $c + d$ as indicated by arrows. The segments of length e are forbidden, and form a branch cut in the glued domain. After decomposing the domain into three sub-domains, we have indicated the transfer matrices needed for the enumeration. As before, we must have a total of d De Bruijn winding loops i.e. going through the glued cut.

4.3. Other symmetry classes of FPL/ASM.

The Razumov-Stroganov conjecture has been generalized to symmetry classes of FPL: the numbers of FPL with certain symmetries and with given connectivity patterns turn out to be related to the ground state vectors of the same $O(1)$ loop model, but with different boundary conditions [16], [9]. The counting of FPL with connectivity $(a, b | e | c, d)$ described above can be naturally restricted to symmetry classes by imposing the corresponding symmetry on the rhombus tiling, or equivalently by dividing out the domain by the symmetry. Here we consider only the symmetry classes for which a Razumov-Stroganov type conjecture is known.

The first class is the so-called half-turn symmetric FPL (HTSFPL), i.e. configurations which are invariant by rotation of π . Naturally, the connectivity pattern itself must be half-turn symmetric, so that we must choose it to be of the form $(a, b | e | a, b)$. The domain is of the form of Fig. 14, and we find that

$$(4.5) \quad N^{HT}(a, b | e | a, b) = \det(I + \mu T_e(a + b))|_{\mu^b}$$

where $T_e(a + b) = T(a + b)X_e(a + b)$ has its entries given by Eq. (3.15) with $1 \leq i, j \leq a + b$.

Note in particular that for $e = 0$ we recover the sequence A045912 of [15] that was implicit in Section 3.1 (Eq. (3.1)); and by summing at

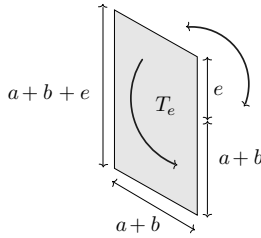

Figure 14. Domain of rhombus tilings for $(a, b | e | a, b)$ HTSFPL.

fixed $n = a + b$, the total number of dimers $\det(I + T(n))$ (Eq. (3.2): sequence A006366 of [15]) which is the number of cyclically symmetric plane partitions in the n -cube. This number also coincides with the ratio of numbers of $2n \times 2n$ half-turn symmetric ASM (HTSASM) and of $n \times n$ ASM. One now finds an indirect proof of the latter fact, via the Razumov-Stroganov conjecture for HTSFPL and FPL. Indeed, there is a projection that sends the ground state eigenvector counting FPL onto the one for HTSFPL. All connectivity patterns that contribute to $N^{HT}(a, b | 0 | a, b)$ are projected⁽²⁾ onto the trivial pattern of n arches for FPLs of size n ; there is only one corresponding FPL, and therefore the sum of such contributions must be related to the relative normalization of the ground state eigenvectors, which can be obtained by taking the sum of all components, i.e. which is equal to the ratio of numbers of $2n \times 2n$ HTSASM and of $n \times n$ ASM.

Next we consider the vertically symmetric FPL (VSFPL), which are invariant by reflection with respect to the vertical axis, and only exist for odd sizes. The connectivity is now $(a, b | e | b, a)$, e odd, and the domain is of the form of Fig. (15) (i). There are exactly a non-intersecting paths, and it is convenient to redefine them as coming out of the side of length a and propagating to the opposite side as depicted. As in Section (3.4), we apply the reflection principle to compute the number of paths in the presence of a “wall”, and then apply the LGV formula:

$$(4.6) \quad N^V(a, b | e | b, a) = \det_{i,j=1,\dots,a} \left(\binom{2b + e + j - 1}{b - j + i} - \binom{2b + e + j - 1}{b - j - i + 1} \right).$$

These numbers were already considered in [9], and have a simple product form [5].

⁽²⁾ Recall that a HT-symmetric pattern of size $2n$ is projected onto a pattern of size n by cutting the disk into two equal sized pieces in any way such that it does not cut an arch, taking one half-disk and gluing it back together into a disk.

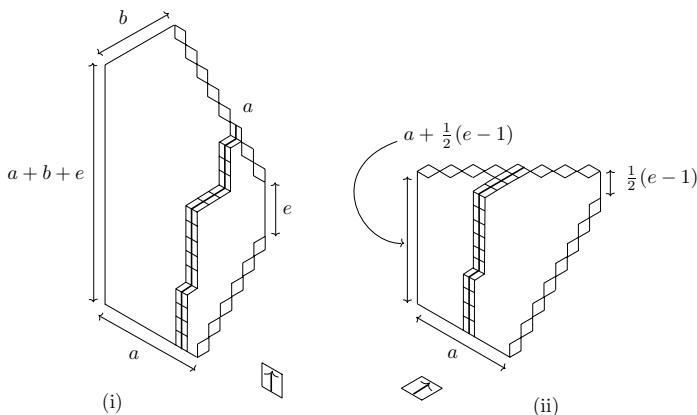

Figure 15. Domains of rhombus tilings for the (i) $(a, b | e | b, a)$ VSFPL and (ii) $(a, 1, a | e | a, 1, a)$ HVSFPL configurations. In each case there are exactly a non-intersecting paths (only one is depicted).

Similarly, the vertically and horizontally symmetric FPL (HVSFPL) are invariant under reflections with respect to both axes. Here the sequence of arches must be slightly modified in order to accommodate the additional symmetry; with the insertion of two single arches, the connectivity pattern becomes $(a, 1, a | e | a, 1, a)$ and the domain is of the form of Fig. 15 (ii). We finally find

$$(4.7) \quad N^{HV}(a, 1, a | e | a, 1, a) = \det_{i,j=1 \dots a} \left(\begin{pmatrix} 2a + \frac{1}{2}(e - 1) - j + 1 \\ a - 2j + i + 1 \end{pmatrix} - \begin{pmatrix} 2a + \frac{1}{2}(e - 1) - j + 1 \\ a - 2j - i + 2 \end{pmatrix} \right).$$

A nice product form for (4.7) may be found in [11] (Theorem 47).

4.4. Plane partitions: q -decoration.

When we view the rhombus tilings of a hexagon as plane partitions, we may introduce yet another catalytic variable, namely a weight q per unit cube in the PP. Many of the above results may thus be “ q -decorated” whenever there exists a PP interpretation. This is for instance the case for the total number of PP in a box of size $a \times b \times c$, which gives a q -MacMahon formula. To express it, we introduce q -deformed corner transfer matrices w, t that keep track of the numbers of boxes in the PP picture. This leads to

$$(4.8) \quad w_{i,j} = q^{\frac{1}{6} + \frac{1}{2}(i-1) + \frac{1}{2}(j-1)^2} \begin{bmatrix} i - 1 \\ j - 1 \end{bmatrix}_q$$

where we have used q -binomials

$$\begin{bmatrix} a \\ b \end{bmatrix}_q = \frac{(1 - q^{b+1})(1 - q^{b+2}) \cdots (1 - q^a)}{(1 - q)(1 - q^2) \cdots (1 - q^{a-b})},$$

and where the prefactors are ad-hoc to take care of boundaries. Similarly, we have $t = ww^t$ reading

$$(4.9) \quad t_{i,j} = q^{\frac{1}{3} + \frac{1}{2}(i+j-2)} \begin{bmatrix} i + j - 2 \\ i - 1 \end{bmatrix}_q.$$

With this definition, we get the q -deformation of the MacMahon formula (2.6)

$$(4.10) \quad N(a, b, c; q) = \det(I + t(a, b)t(b, c)t(c, a)) = \prod_{i=1}^a \prod_{j=1}^b \prod_{k=1}^c \frac{1 - q^{i+j+k-1}}{1 - q^{i+j+k-2}}$$

for the generating function $N(a, b, c; q)$ for PP in a box $a \times b \times c$ with a weight q per unit cube. Combining this with Eq. (2.9), we also get the generating function $N(a, b, c; q, \mu)$ for PP in a box $a \times b \times c$ with a weight q per unit cube, and with a weight μ per De Bruijn loop in the tiling picture

$$(4.11) \quad N(a, b, c; q, \mu) = \det(I + \mu t(a, b)t(b, c)t(c, a)).$$

With the matrix t , we have also access to the generating function $N^{CS}(a; q, \mu)$ for the numbers of cyclically symmetric plane partitions in a box $a \times a \times a$, weighted by q per unit cube, and μ per winding De Bruijn loop, namely

$$(4.12) \quad N^{CS}(a; q, \mu) = \det(I + \mu t(a))$$

provided q is replaced by q^3 in the definition of t (as the total number of boxes is three times that in any of the three identical copies of the parallelogram that form the total hexagon).

Finally, we get the generating function $N^{HH}(a; q, \mu)$ for the numbers of “vertically symmetric partitions” corresponding to the tiling of the glued half-hexagons of Section 3.2, with an additional weight q per unit cube and μ per winding De Bruijn loop

$$(4.13) \quad N^{HH}(a; q, \mu) = \det(I + \mu w(a)w^t(a)w(a))$$

provided q is replaced by q^2 in the definition of w (as the plane partition is obtained by completing the (opened) half-hexagon with its reflection).

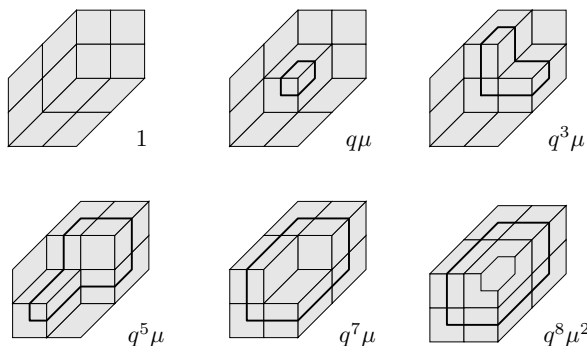

Figure 16. Vertically symmetric plane partitions in a box $a \times a \times a$ corresponding to the tiling of a glued half-hexagon, for $a = 2$. For each partition, we have indicated the contribution to the generating function $N^{HH}(2; q, \mu) = 1 + q\mu + q^3\mu + q^5\mu + q^7\mu + q^8\mu^2$.

These partitions are represented in Fig. 16 for $a = 2$. We may also write a q -deformed version of the Poincaré polynomial (3.11) for 2-step nilpotent Lie algebras of rank a :

$$(4.14) \quad P_a(u; q) = \det \left(I + \frac{1}{\sqrt{q}} \theta w(a) w^t(a) w(a) \right)$$

with the matrix θ as in (3.12). The latter corresponds presumably to a sum over Schur functions of the form $\sum_{Y=Y^T} s_Y(x_q) u^{|Y|}$, with the specialization $x = x_q \equiv \{1, q, q^2, \dots, q^{a-1}\}$. The coefficients of $P_a(u; q)$ as a function of u are q -deformed dimensions of homology spaces, and await a good interpretation in the Lie algebraic context. For illustration, we have

$$(4.15) \quad P_3(u; q) = 1 + u(1 + q + q^2) + u^3 q^2(1 + q)^2(1 + q^2) \\ + u^4 q^3(1 + q^2)(1 + q + q^2) + u^5 q^5(1 + q^2)(1 + q + q^2) \\ + u^6 q^6(1 + q)^2(1 + q^2) + u^8 q^{10}(1 + q + q^2) + u^9 q^{12}.$$

5. Conclusion.

We have provided expressions for the numbers of rhombus tilings of certain regions of the plane with some gluing conditions. Sometimes these expressions were directly determinants, sometimes they were coefficients in the expansion of a determinant in powers of a variable, in a way similar to grand canonical vs canonical partition functions. We used transfer matrix

techniques, in analogy with Baxter's corner transfer matrix. We have applied these ideas to the computation of the numbers of FPL for a fairly general class of connectivities, with and without additional symmetries. Various issues remain open.

5.1. FPL and rhombus tilings.

In view of Sections 4.2 and 4.3, one may wonder whether there exists a deeper connection between FPL configurations with prescribed connectivities and rhombus tilings of possibly cut and/or glued domains of the plane.

The answer to this question must be subtle as was already observed in the case of four sets of nested lines [8]: Indeed in that case, only a few rotated versions (in the sense of Wieland [18]) of the FPL counting problem allowed for a straightforward bijection with rhombus tilings of the domains of Figure 11. In the general case, we must first optimize the Wieland rotation in order to attack the problem.

Another relation to rhombus tiling, though very hypothetical, would first involve finding a bijection between FPL/ASM and totally symmetric self-complementary plane partitions (TSSCPP), themselves reducible to the rhombus tilings of triangles with free boundary conditions along one side. The number of TSSCPP in a box of size $2a \times 2a \times 2a$ was shown to match that of $a \times a$ FPL/ASM, but no natural bijection is available yet between the two sets [3]. If we knew such a bijection, we could characterize among TSSCPP the rhombus tilings corresponding to FPL configurations with fixed connectivities, thus provide an answer to the above question. This answer, however, would not coincide with that of Section 4.2 in the case of four sets of lines separated by a fifth one, as the domain considered do not match in any simple way.

Answering this question remains an interesting challenge.

5.2. Asymptotic enumeration.

A by-product of our work has been to provide us with new data for FPL configuration numbers, either by explicit determinant formulae, or just numerical. It is tempting to try to extract the asymptotic behavior for large configurations of a given type. This is in particular the case for the configurations denoted $(\)_r^p$ in [14], i.e. made of p sets of r arches, for which we conjecture that for p large, r fixed, or vice versa (and $n = pr$)

$$(5.1) \quad \log \#((\)_r^p) \approx \kappa r^2 ((p-1)^2 - 1) + \mathcal{O}(\log n)$$

with the same $\kappa = \frac{1}{2} \log \frac{27}{16}$ that appears in the asymptotics of A_n ,

$$(5.2) \quad A_n \approx n^{-\frac{23}{36}} e^{\kappa n^2}.$$

$p \setminus r$	1	2	3	4	α_p
2	1	1	1	1	0
3	2	20	980	232848	$\frac{3}{2}$
4	7	3504	118565449	266866085641550	~ 4 (*)
5	42	5100260	1637273349805800	...	$\sim \frac{15}{2}$?
6	429	60908609580	...		
7	7436	5939300380261111	...		
8	218348	4717858636573174999768	...		
β_r	$\frac{1}{2}$	$\sim 2?$	$\sim \frac{9}{2}?$		

Table 1. Numbers of FPL configurations $(\)_r^p$ with p sets of r arches. (*) See the text for justification. In each column, as $p \rightarrow \infty$, there is good evidence that the numbers behave as $(\frac{27}{16})^{\beta_r p^2}$, with numbers β_r as shown; likewise, along each row, $r \rightarrow \infty$, behavior as $(\frac{27}{16})^{\alpha_p r^2}$, with α_p as shown. The expression in (5.1) is consistent with these data.

The conjecture (5.1) agrees with some particular cases. For $r = 1$, all $p = n$, we have configurations with n simple arches, whose number is A_{n-1} , as conjectured in [2], and whose asymptotics is thus given by (5.2) (with $n \mapsto n - 1$). For $p = 3, r = \frac{1}{3}n$, we have the MacMahon formula, the asymptotics of which is easy to calculate. Our conjecture is also supported by the observation that the number of 4-arch configurations $(\)_r^4, r = \frac{1}{4}n$, is given by the middle term in the expansion of $\det(x + T^2)$, with T the Pascal matrix (2.4), and is in fact the dominant coefficient in that polynomial in x . Then Mitra-Nienhuis [13] conjecture on $\det(i1 + T) \sim (A^{\text{HT}}(L = 2r))^2$ together with the known asymptotic behavior of half-turn symmetric ASM, $A^{\text{HT}}(L) \sim (\frac{27}{16})^{\frac{1}{4}L^2}$, gives $\log \#(\)_r^4 \sim \frac{1}{2}8r^2 \log \frac{27}{16}$. Last but not least, our conjecture (5.1) is well supported by numerical data, as shown in Table 1.

Acknowledgments. — Many thanks to Gleb Koshevoy, Christian Krattenthaler and Nikolai Reshetikhin for discussions and suggestions. This work was partly supported by the TMR network EUCLID HPRN-CT-2002-00325.

This work is dedicated to our friend Pierre van Moerbeke on the occasion of his sixtieth birthday, and we are happy to wish him many more years of exciting research.

BIBLIOGRAPHY

- [1] M. ADLER, P. VAN MOERBEKE, Virasoro action on Schur function expansions, skew Young tableaux and random walks, *Comm. Pure Appl. Math.*, 58 (2005), vol. 3, 362–408 (math.PR/0309202).
- [2] M.T. BATCHELOR, J. DE GIER, B. NIENHUIS, The quantum symmetric XXZ chain at $\Delta = -\frac{1}{2}$, alternating sign matrices and plane partitions, *J. Phys. A*, 34 (2001), L265–L270, (cond-mat/0101385).
- [3] D. BRESSOUD, Proofs and confirmations. The story of the alternating sign matrix conjecture, Cambridge University Press, 1999.
- [4] F. CASELLI, C. KRATTENTHALER, Proof of two conjectures of Zuber on fully packed loop configurations, *J. Combin. Theory Ser. A*, 108 (2004), 123–146, (math.CO/0312217).
- [5] M. CIUCU, C. KRATTENTHALER, Enumeration of lozenge tilings of hexagons with cut-off corners, *J. Combin. Theory Ser. A*, 100 (2002), 201–231, (math.CO/0104058).
- [6] M. CIUCU, C. KRATTENTHALER, T. EISENKÖLBL, D. ZARE, Enumeration of lozenge tilings of hexagons with a central triangular hole, *J. Combin. Theory Ser. A*, 95 (2001), 251–334 (math.CO/9910053); C. Krattenthaler, Descending plane partitions and rhombus tilings of a hexagon with triangular hole, (math.CO/0310188).
- [7] P. DI FRANCESCO, P. ZINN-JUSTIN, J.-B. ZUBER, A bijection between classes of fully packed loops and plane partitions, *Electron. J. Combin.*, 11-1 (2004), #R64 (math.CO/0311220).
- [8] P. DI FRANCESCO, J.-B. ZUBER, On FPL configurations with four sets of nested arches, *JSTAT* (2004), P06005, (cond-mat/0403268).
- [9] J. DE GIER, Loops, matchings and alternating-sign matrices, (math.CO/0211285).
- [10] J. GRASSBERGER, A. KING, P. TIRAO, On the homology of free 2-step nilpotent Lie algebras, *J. Algebra*, 254 (2002), 213–225.
- [11] C. KRATTENTHALER, Advanced determinant calculus, *Séminaire Lotharingien Combin.*, 42 (“The Andrews Festschrift”) (1999), Article B42q, (math.CO/9902004).
- [12] B. LINDSTRÖM, On the vector representations of induced matroids, *Bull. London Math. Soc.*, 5 (1973), 85–90; I.M. Gessel and X. Viennot, Binomial determinants, paths and hook formulae, *Adv. Math.* 58 (1985), 300–321.
- [13] S. MITRA, B. NIENHUIS, Osculating random walks on cylinders, pp. 259–264 in *Discrete random walks, DRW’03* (C. Banderier and C. Krattenthaler eds.), *Discrete Mathematics and Computer Science Proceedings AC*, 2003, (math-ph/0312036).
- [14] S. MITRA, B. NIENHUIS, J. DE GIER, M.T. BATCHELOR, Exact expressions for correlations in the ground state of the dense $O(1)$ loop model, *JSTAT* (2004), P09010, (cond-math/0401245).

- [15] ON-LINE ENCYCLOPEDIA OF INTEGER SEQUENCES, <http://www.research.att.com/~njas/sequences/Seis.html>.
- [16] P.A. PEARCE, V. RITTENBERG, J. DE GIER, Critical $Q = 1$ Potts model and temperley-Lieb stochastic processes, (cond-mat/0108051); A.V. Razumov, Yu.G. Stroganov, $O(1)$ loop model with different boundary conditions and symmetry classes of alternating-sign matrices, *Teor. Mat. Fiz.* 142 (2005), 284–292, (cond-mat/0108103).
- [17] A.V. RAZUMOV, Yu.G. STROGANOV, Combinatorial nature of ground state vector of $O(1)$ loop model, *Theor. Math. Phys.*, 138 (2004), 333–337; *Teor. Mat. Fiz.* 138 (2004), 395–400, (math.CO/0104216).
- [18] B. WIELAND, A large dihedral symmetry of the set of alternating-sign matrices, *Electron. J. Combin.*, 7 (2000), #R37, (math.CO/0006234).

Philippe DI FRANCESCO,
 Service de Physique Théorique de Saclay
 CEA/DSM/SPhT, URA 2306 du CNRS
 CEA-Saclay
 91191 Gif sur Yvette Cedex (France)
philippe@spht.saclay.cea.fr

Paul ZINN-JUSTIN,
 LIFR-MIIP, Independent University
 119002 Bolshoy Vlasyevskiy Pereulok 11
 Moscow (Russia)
 Laboratoire de Physique Théorique et Modèles Statistiques
 UMR 8626 du CNRS
 Université Paris-Sud, Bâtiment 100
 91405 Orsay Cedex (France)
pzinn@ipno.in2p3.fr

Jean-Bernard ZUBER,
 Université Paris 6
 LPTHE, Tour 24
 75231 Paris Cedex 05 (France)
 Service de Physique Théorique de Saclay
 CEA/DSM/SPhT, URA 2306 du CNRS
 91191 Gif sur Yvette Cedex (France)
zuber@lpthe.jussieu.fr